

**Preliminary**

## GENERAL DESCRIPTION

EM73C63 is an advanced single chip CMOS 4-bit micro-controller. It contains 32K-byte ROM, 500-nibble RAM, 4-bit ALU, 13-level subroutine nesting, 22-stage time base, two 12-bit timer/counters for the kernel function. EM73C63 is also equipped with 5 interrupt sources, 3 I/O ports (including 1 input port and 2 bidirection ports), LCD display (40x16), built-in sound generator.

Its low power consumption and high speed feature are further strengthened with DUAL, SLOW, IDLE and STOP operation mode for optimized power saving.

## FEATURES

- Operation voltage : 2.4V to 5.5V.
- Clock source : Dual clock system. Low-frequency oscillator is Crystal or RC oscillator (32KHz, connect a external resistor) by mask option and high-frequency oscillator is RC oscillator (connect a external resistor and a capacitor).  
External clock and internal clock is available by mask option.
- Oscillation frequency : 480K, 1M, 2M and 4M Hz are both available for high frequency clock by mask option.
- Instruction set : 107 powerful instructions.
- Instruction cycle time : Up to 2  $\mu$ s for 4 MHz (high speed clock).  
244  $\mu$ s for 32768 Hz (low speed clock).
- ROM capacity : 32768 X 8 bits.
- RAM capacity : 500 X 4 bits.
- Input port : 1 port (P0.0-P0.3), IDEL/STOP releasing function is available by mask option. (each input pin has a pull-up and pull-down resistor available by mask option).
- Bidirection port : 2 ports (P4, P8). P4.0 and SOUND are available by mask option. IDEL/STOP releasing function for P8(0..3) is available by mask option.
- 12-bit timer/counter : Two 12-bit timer/counters are programmable for timer, event counter and pulse width measurement mode.
- Built-in time base counter : 22 stages.
- Subroutine nesting : Upto 13 levels.
- Interrupt : External . . . . . 2 input interrupt sources.  
Internal . . . . . 2 Timer overflow interrupts.  
1 Time base interrupt.
- LCD driver : 40 X 16 dots, 1/16 duty, 1/5 bias with voltage multiplier.
- Sound effect : Tone generator, random generator and volume control.
- Power saving function: SLOW, IDLE, STOP operation modes.
- Package type : Chip form 84 pins, PLCC 84 pins.

**Preliminary**

**FUNCTION BLOCK DIAGRAM**

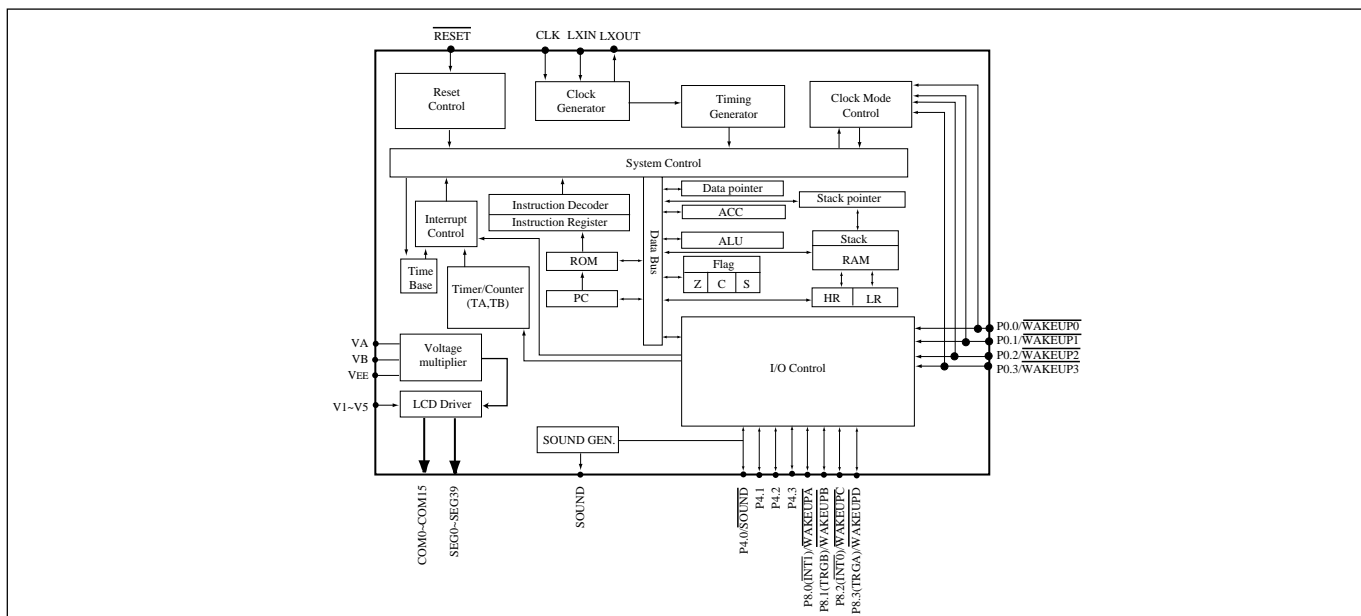

**PIN DESCRIPTIONS**

Symbol	Pin-type	Function
$V_{DD}$		Power supply (+)
$V_{SS}$		Power supply (-)
RESET	RESET-A	System reset input signal, low active mask option : none pull-up
CLK	OSC-C	RC or external clock source connecting pin for high speed clock source.
LXIN	OSC-B/OSC-F	Crystal/RC connecting pin for low speed clock source.
LXOUT	OSC-B/OSC-F	Crystal/RC connecting pin for low speed clock source.
P0(0..3)/WAKEUP0..3	INPUT-B	4-bit input port with IDLE/STOP releasing function mask option : wakeup enable, pull-up wakeup enable, none wakeup disable, pull-up wakeup disable, pull-down wakeup disable, none
P4.0/SOUND	I/O-O	1-bit bidirection I/O port or inverse sound effect output mask option : SOUND enable, push-pull, high current PMOS SOUND disable, open-drain SOUND disable, push-pull, high current PMOS SOUND disable, push-pull, low current PMOS
P4(1..3)	I/O-O	3-bit bidirection I/O port with high current source. mask option : open-drain push-pull, high current PMOS push-pull, low current PMOS
P8.0(INT1)/WAKEUPA P8.2(INT0)/WAKEUPC	I/O-L	2-bit bidirection I/O port with external interrupt sources input and IDLE /STOP releasing function mask option : wakeup enable, push-pull wakeup disable, push-pull wakeup disable, open-drain
P8.1(TRGB)/WAKEUPB	I/O-L	2-bit bidirection I/O port with time/counter A,B external input and IDLE

\* This specification are subject to be changed without notice.

*Preliminary*

Symbol	Pin-type	Function
P8.3(TRGA)/WAKEUPD		/STOP releasing function mask option :       wakeup enable, push-pull wakeup disable, push-pull wakeup disable, open-drain
SOUND		Built-in sound effect output
VA, VB, VEE		LCD voltage multiplier connect pins
V1, V2, V3, V4, V5		LCD bias voltage connect pins
COM0~COM15		LCD common output pins
SEG0~SEG39		LCD segment output pins
TEST		Tie Vss as package type, no connecting as COB type.

**FUNCTION DESCRIPTIONS**

**PROGRAM ROM (32Kx8bits)**

32 K x 8 bits program ROM contains user's program and some fixed data.

The basic structure of the program ROM may be categorized into 5 partitions.

1. Address 0000h: Reset start address.
2. Address 0002h - 000Ch : 5 kinds of interrupt service routine entry addresses .
3. Address 000Eh-0086h : SCALL subroutine entry address, only available at 000Eh,0016h,001Eh,0026h, 002Eh, 0036h, 003Eh, 0046h, 004Eh, 0056h, 005Eh, 0066h, 006Eh, 0076h, 007Eh, 0086h .
4. Address 0000h - 07FFh : LCALL subroutine entry address.
5. Address 0000h- 1FFFh: Except used as above function, the other region can be used as user's program and data region.  
address    Bank 0:

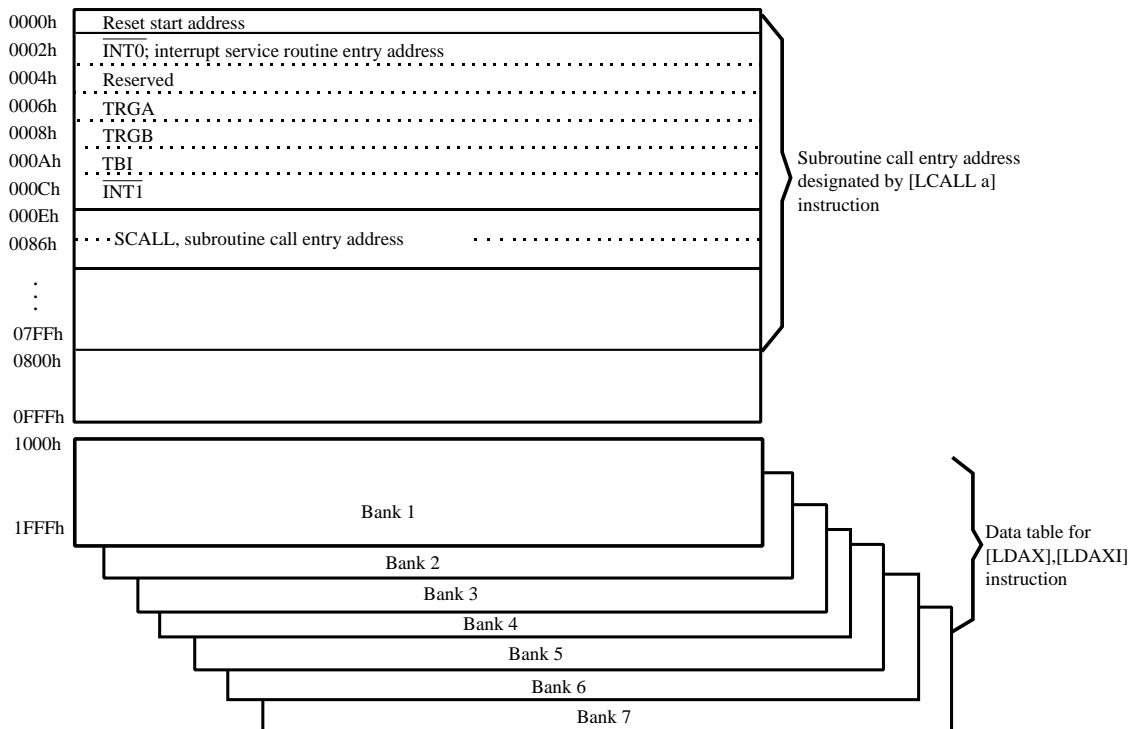

## Preliminary

User's program and fixed data are stored in the program ROM. User's program is executed using the PC value to fetch an instruction code.

The 32Kx8bits program ROM can be divided into 8 banks. There are 4Kx8bits per bank.

The program ROM bank is selected by P3(2..0). The program counter is a 13-bit binary counter. The PC and P3 are initialized to "0" during reset.

When P3(2..0)=000B, the bank0 and bank1 of program ROM will be selected. P3(2..0)=001B, the bank0 and bank2 will be selected, and so on.

Address	P3=x000B	P3=x001B	P3=x010B	P3=X011B	P3=X100B	P3=X101B	P3=X110B
0000h	Bank0	Bank0	Bank0	Bank0	Bank0	Bank0	Bank0
:							
0FFFh							
1000h	Bank1	Bank2	Bank3	Bank4	Bank5	Bank6	Bank7
:							
1FFFh							

**PROGRAM EXAMPLE:**

```

BANK 0
START:  :
        :
        :
        LDIA #00H           ; set program ROM to bank1
        OUTA P3
        B    XA1
        :
XA:     :
        :
        LDIA #01H           ; set program ROM to bank2
        OUTA P3
        B    XB1
        :
XB:     :
        :
        LDIA #02H           ; set program ROM to bank3
        OUTA P3
        B    XC1
        :
XC:     :
        :
        B    XD
XD:     :
        :
        :
;-----;
BANK 1
XA1:    :
        :
        B    XA
        :
XA2:    :
    
```

**Preliminary**

```

        B      XA2
        :
;-----
        BANK 2
XB1 :      :
        :      :
        B      XB
        :      :
XB2 :      :
        B      XB2
        :
;-----
        BANK 3
XC1 :      :
        :      :
        B      XC
        :      :
XC2 :      :
        B      XC2
    
```

Fixed data can be read out by table-look-up instruction. Table-look-up instruction requires the Data point (DP) to indicate the ROM address in obtaining the ROM code data (Except bank0) :

```

LDAX      Acc ← ROM[DP]L
LDAXI     Acc ← ROM[DP]H,DP+1
    
```

DP is a 12-bit data register that stores the program ROM address as pointer for the ROM code data. User has to initially load ROM address into DP with instructions "STADPL", and "STADPM", "STADPH", then to obtain the lower nibble of ROM code data by instruction "LDAX" and higher nibble data by instruction "LDAXI".

PROGRAM EXAMPLE: Read out the ROM code of address 1777h by table-look-up instruction.

```

LDIA #07h;
STADPL    ; [DP]L ← 07h
STADPM    ; [DP]M ← 07h
STADPH    ; [DP]H ← 07h, Load DP=777h
:
OUT #00H, P3 ; Set in bank 1
LDL #00h;
LDH #03h;
LDAX      ; ACC ← 6h
STAMI     ; RAM[30] ← 6h
LDAXI     ; ACC ← 5h
STAM      ; RAM[31] ← 5h
;
ORG 1777h
DATA 56h;
    
```

#### DATA RAM ( 500-nibble )

A total 500 - nibble data RAM is available from address 000 to 1FFh  
Data RAM includes the zero page region, stacks and data areas.

**Preliminary**

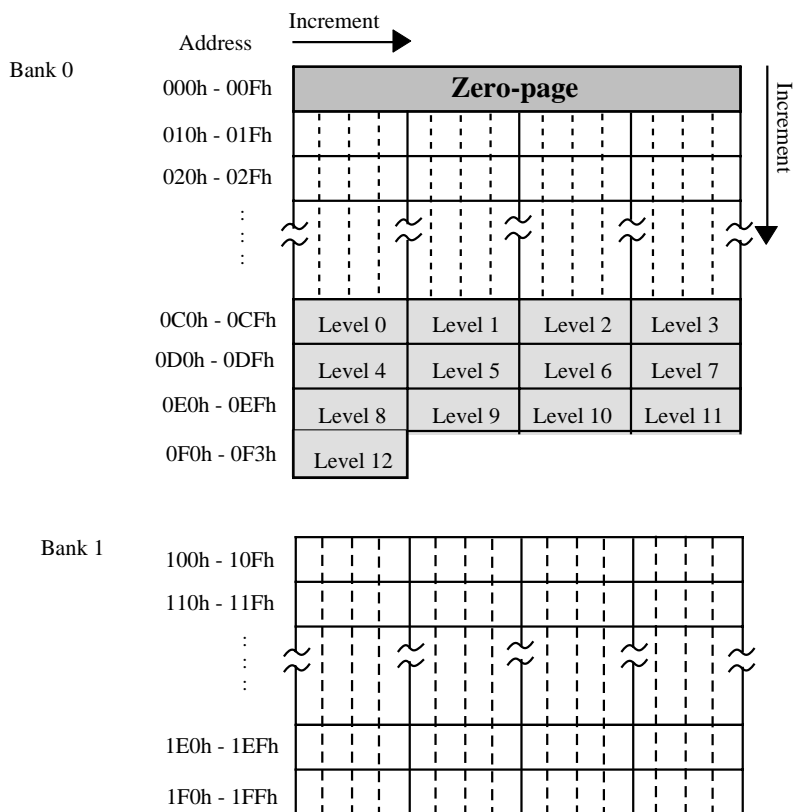

**ZERO- PAGE:**

From 000h to 00Fh is the zero-page location. It is used as the zero -page address mode pointer for the instruction of "STD #k,y; ADD #k,y; CLR y,b; CMP k,y".

**PROGRAM EXAMPLE:** To write immediate data "07h" to RAM [03] and to clear bit 2 of RAM [0Eh].  
 STD #07h, 03h ; RAM[03] ← 07h  
 CLR 0Eh,2 ; RAM[0Eh]<sub>2</sub> ← 0

**STACK:**

There are 13 - level (maximum) stack levels that user can use for subroutine (including interrupt and CALL). User can assign any level be the starting stack by providing the level number to stack pointer (SP) . When an instruction (CALL or interrupt) is invoked, before enter the subroutine, the previous PC address is saved into the stack until returned from those subroutines, the PC value is restored by the data saved in stack.

**DATA AREA:**

Except the area used by user's application, the whole RAM can be used as data area for storing and loading general data.

**ADDRESSING MODE**

The 500 nibble data memory consists of two banks (bank 0 and bank 1). There are 244x4 bits (address 000h~0F3h) in bank 0 and 256x4 bits (address 100h~1FFh) in bank 1.

## Preliminary

The bank is selected by P9.3. When P9.3 is cleared to "0", the bank 0 is selected. When P9.3 is set to "1", the bank 1 is selected.

The Data Memory consists of three Address mode, namely -

(1) Indirect addressing mode:

The address in the bank is specified by the HL registers.

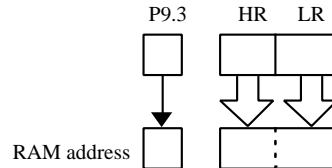

PROGRAM EXAMPLE: Load the data of RAM address "143h" to RAM address "032h".

```

SEP P9,3 ; P9.3← 1
LDL #3h ; LR← 3
LDH #4h ; HR← 4
LDAM ; Acc← RAM[134h]
CLP P9,3 ; P9.3← 0
LDL #2h ; LR← 2
LDH #3h ; HR← 3
STAM ; RAM[023h]← Acc
    
```

(2) Direct addressing mode:

The address in the bank is directly specified by 8 bits code of the second byte in the instruction field.

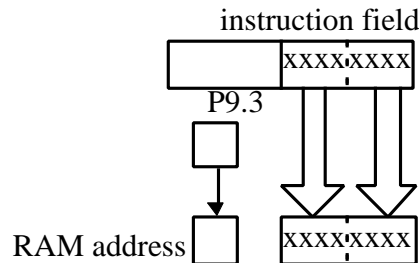

PROGRAM EXAMPLE: Load the data of RAM address "143h" to RAM address "023h".

```

SEP P9,3 ; P9.3← 1
LDA 43h ; Acc← RAM[143h]
CLP P9,3 ; P9.3← 0
STA 23h ; RAM[023h]← Acc
    
```

(3) Zero-page addressing mode:

The zero-page is in the bank 0 (address 000h~00Fh). The address is the lower 4 bits code of the second byte in the instruction field.

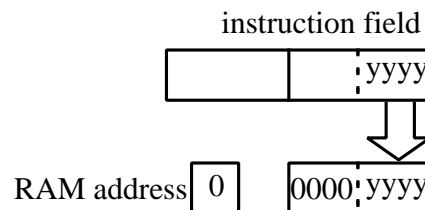

PROGRAM EXAMPLE: Write immediate "0Fh" to RAM address "005h".

```

STD #0Fh, 05h ; RAM[05h]← 0Fh
    
```

Preliminary

### PROGRAM COUNTER (32K ROM)

Program counter ( PC ) is composed by a 13-bit counter, which indicates the next executed address for the program ROM instruction.

For BRANCH and CALL instructions, PC is changed by instruction indicating. PC only can indicate the address from 0000h~1FFFh. The bank number is decided by P3.

#### (1) Branch instruction:

##### SBR a

Object code: 00aa aaaa

Condition: SF=1; PC ← PC<sub>12-6.a</sub> ( branch condition satisfied )

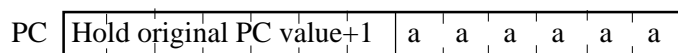

SF=0; PC← PC +1( branch condition not satisfied)

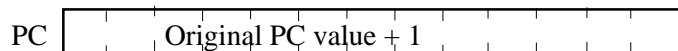

##### LBR a

Object code: 1100 aaaa aaaa aaaa

Condition: SF=1; PC ← PC<sub>12.a</sub> ( branch condition satisfied )

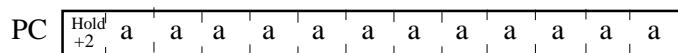

SF=0; PC← PC +2( branch condition not satisfied)

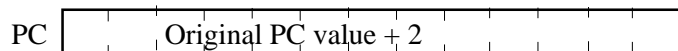

##### SLBR a

Object code: 0101 0101 1100 aaaa aaaa aaaa (a:1000h~1FFFh)

0101 0111 1100 aaaa aaaa aaaa (a:0000h~0FFFh)

Condition: SF=1; PC ← a ( branch condition satisfied)

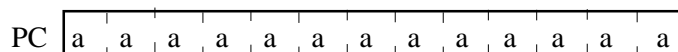

SF=0 ; PC ← PC + 3 ( branch condition not satisfied )

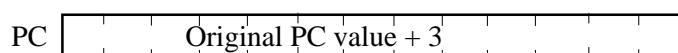

#### (2) Subroutine instruction:

##### SCALL a

Object code: 1110 nnnn

Condition : PC ← a ; a=8n+6 ; n=1..Fh ; a=86h, n=0

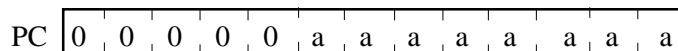

##### LCALL a

Object code: 0100 0aaa aaaa aaaa

Condition: PC ← a



**Preliminary**

PC 

0	0	a	a	a	a	a	a	a	a	a	a	a
---	---	---	---	---	---	---	---	---	---	---	---	---

**RET**

Objectcode:01001111

Condition: PC ← STACK[SP]; SP+1

PC 

The return address stored in stack												
------------------------------------	--	--	--	--	--	--	--	--	--	--	--	--

**RHI**

Objectcode:01001101

Condition: FLAG.PC ← STACK[SP]; EI ← 1; SP+1

PC 

The return address stored in stack												
------------------------------------	--	--	--	--	--	--	--	--	--	--	--	--

**(3) Interrupt acceptance operation:**

When an interrupt is accepted, the original PC is pushed into stack and interrupt vector will be loaded into PC, The interrupt vectors are as follows:

$\overline{INT0}$  (External interrupt from P8.2)

PC 

0	0	0	0	0	0	0	0	0	0	0	0	1	0
---	---	---	---	---	---	---	---	---	---	---	---	---	---

**TRGA** (Timer A overflow interrupt)

PC 

0	0	0	0	0	0	0	0	0	0	0	1	1	0
---	---	---	---	---	---	---	---	---	---	---	---	---	---

**TRGB** (Time B overflow interrupt)

PC 

0	0	0	0	0	0	0	0	0	0	1	0	0	0
---	---	---	---	---	---	---	---	---	---	---	---	---	---

**TBI** (Time base interrupt)

PC 

0	0	0	0	0	0	0	0	0	0	1	0	1	0
---	---	---	---	---	---	---	---	---	---	---	---	---	---

$\overline{INT1}$  (External interrupt from P8.0)

PC 

0	0	0	0	0	0	0	0	0	0	1	1	0	0
---	---	---	---	---	---	---	---	---	---	---	---	---	---

**(4) Reset operation:**

PC 

0	0	0	0	0	0	0	0	0	0	0	0	0	0
---	---	---	---	---	---	---	---	---	---	---	---	---	---

**(5) Other operations:**

- For 1-byte instruction execution: PC + 1
- For 2-byte instruction execution: PC + 2
- For 3-byte instruction execution: PC + 3

**Preliminary**

## ACCUMULATOR

Accumulator(ACC) is a 4-bit data register for temporary data storage. For the arithmetic, logic and comparative operation., ACC plays a role which holds the source data and result .

## FLAGS

There are three kinds of flag, CF ( Carry flag ), ZF ( Zero flag ) and SF ( Status flag ), these three 1-bit flags are included by the arithmetic, logic and comparative .... operation .

All flags will be put into stack when an interrupt subroutine is served, and the flags will be restored after RTI instruction is executed .

### (1) Carry Flag ( CF )

The carry flag is affected by the following operations:

- a. Addition : CF as a carry out indicator, under addition operation, when a carry-out occurs, the CF is "1", likewise, if the operation has no carry-out, the CF is "0".
- b. Subtraction : CF as a borrow-in indicator, under subtraction operation, when a borrow occurs, the CF is "0", likewise, if there is no borrow-in, the CF is "1".
- c. Comparison: CF as a borrow-in indicator for Comparison operation as in the subtraction operation.
- d. Rotation: CF shifts into the empty bit of accumulator for the rotation and holds the shift out data after rotation.
- e. CF test instruction : Under TFCFC instruction, the CF content is sent into SF then clear itself as "0". Under TTSFC instruction, the CF content is sent into SF then set itself as "1".

### (2) Zero Flag ( ZF )

ZF is affected by the result of ALU, if the ALU operation generates a "0" result, the ZF is "1", likewise, the ZF is "0".

### (3) Status Flag ( SF )

The SF is affected by instruction operation and system status .

- a. SF is initiated to "1" for reset condition .
- b. Branch instruction is decided by SF, when SF=1, branch condition is satisfied, likewise, when SF = 0, branch condition is unsatisfied .

## PROGRAM EXAMPLE:

Check following arithmetic operation for CF, ZF, SF

	CF	ZF	SF
LDIA #00h;	-	1	1
LDIA #03h;	-	0	1
ADDA #05h;	-	0	1
ADDA #0Dh;	-	0	0
ADDA #0Eh;	-	0	0

**Preliminary**

## ALU

The arithmetic operation of 4 - bit data is performed in ALU unit . There are 2 flags that can be affected by the result of ALU operation, ZF and SF . The operation of ALU is affected by CF only .

## ALU STRUCTURE

ALU supported user arithmetic operation functions, including Addition, Subtraction and Rotaion.

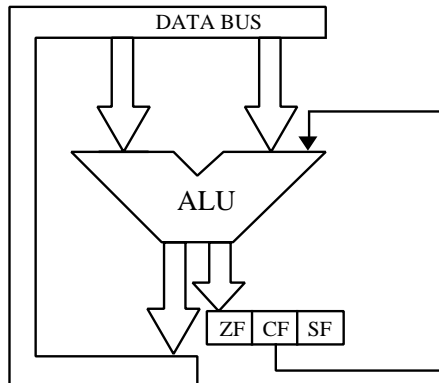

## ALU FUNCTION

(1) Addition:

ALU supports addition function with instructions ADDAM, ADCAM, ADDM #k, ADD #k,y .... .

The addition operation affects CF and ZF. Under addition operation, if the result is "0", ZF will be "1", otherwise, ZF will be "0", When the addition operation has a carry-out. CF will be "1", otherwise, CF will be "0".

EXAMPLE:

Operation	Carry	Zero
3+4=7	0	0
7+F=6	1	0
0+0=0	0	1
8+8=0	1	1

(2) Subtraction:

ALU supports subtraction function with instructions SUBM #k, SUBA #k, SBCAM, DECM... . The subtraction operation affects CF and ZF, Under subtraction operation, if the result is negative, CF will be "0", and a borrow out, otherwise, if the result is positive, CF will be "1". For ZF, if the result of subtraction operation is "0", the ZF is "1", likewise, ZF is "1".

EXAMPLE:

Operation	Carry	Zero
8-4=4	1	0
7-F= -8(1000)	0	0
9-9=0	1	1

**Preliminary**

(3) Rotation:

Two types of rotation operation are available, one is rotation left, the other is rotation right. RLCA instruction rotates Acc value counter-clockwise, shift the CF value into the LSB bit of Acc and hold the shift out data in CF.

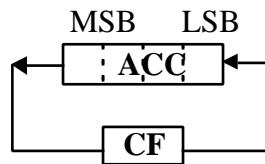

RRCA instruction operation rotates Acc value clockwise, shift the CF value into the MSB bit of Acc and hold the shift out data in CF.

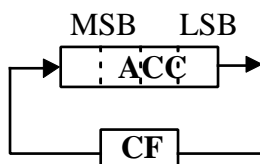

PROGRAM EXAMPLE: To rotate Acc clockwise (right) and shift a "1" into the MSB bit of Acc .

```
TTCFS; CF ← 1
RRCA; rotate Acc right and shift CF=1 into MSB.
```

**HL REGISTER**

HL register are two 4-bit registers, they are used as a pair of pointer for the RAM memory address. They are used as also 2 independent temporary 4-bit data registers. For certain instructions, L register can be a pointer to indicate the pin number ( Port4 only ) .

**HL REGISTER STRUCTURE**

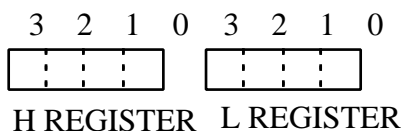

**HL REGISTER FUNCTION**

(1) HL register is used as a temporary register for instructions : LDL #k, LDH #k, THA, THL, INCL, DECL, EXAL, EXAH, .

```
PROGRAM EXAMPLE: Load immediate data "5h" into L register, "0Dh" into H register.
LDL #05h;
LDH #0Dh;
```

(2) HL register is used as a pointer for the address of RAM memory for instructions : LDAM, STAM, STAMI ..

```
PROGRAM EXAMPLE: Store immediate data "#0Ah" into RAM of address 35h.
```

**Preliminary**

```
LDL #5h;
LDH #3h;
STDMI #0Ah; RAM[35] ← Ah
```

- (3) L register is used as a pointer to indicate the bit of I/O port for instructions : SELP, CLPL, TFPL,  
(When LR = 0 indicate P4.0)

**PROGRAM EXAMPLE:** To set bit 0 of Port4 to "1"  
LDL #00h;  
SEPL ; P4.0 ← 1

### STACK POINTER (SP)

Stack pointer is a 4-bit register that stores the present stack level number. Before using stack, user must set the SP value first, CPU will not initiate the SP value after reset condition. When a new subroutine is received, the SP is decreased by one automatically, likewise, if returning from a subroutine, the SP is increased by one. The data transfer between ACC and SP is done with instructions "LDASP" and "STASP".

### DATA POINTER (DP)

Data pointer is a 12-bit register that stores the ROM address can indicating the ROM code data specified by user (refer to data ROM).

### CLOCK AND TIMING GENERATOR

The clock generator is supported by a dual clock system. The high-frequency oscillator is sourced from RC oscillator, the working frequency range is 480 KHz to 4 MHz defined by the mask option. The low-frequency oscillator may be sourced from crystal or RC oscillator as defined by mask option, the working frequency is 32 KHz.

### CLOCK GENERATOR STRUCTURE

There are two clock generator for system clock control unit, P14 is the status register that hold the CPU status. P16, P19 and P22 are the command register for system clock mode control.

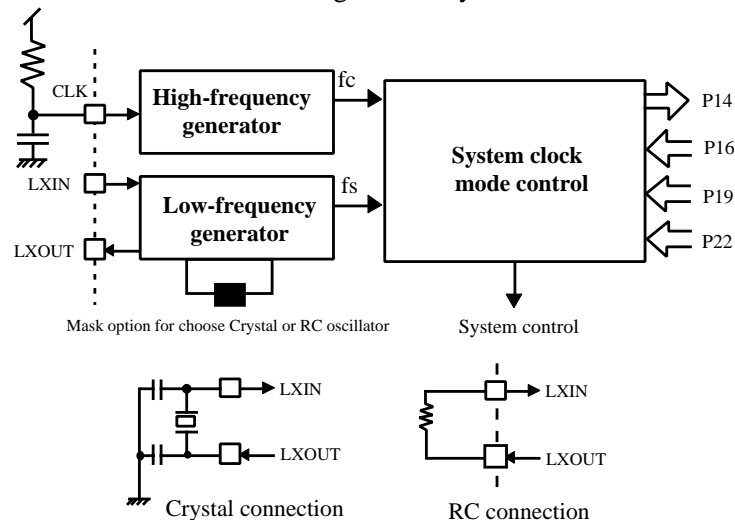

**Preliminary**

**SYSTEM CLOCK MODE CONTROL**

The system clock mode controller can start or stop the high-frequency and low-frequency clock oscillator and switch between the basic clocks. EM73C63 has four operation modes (DUAL, SLOW, IDLE and STOP operation modes).

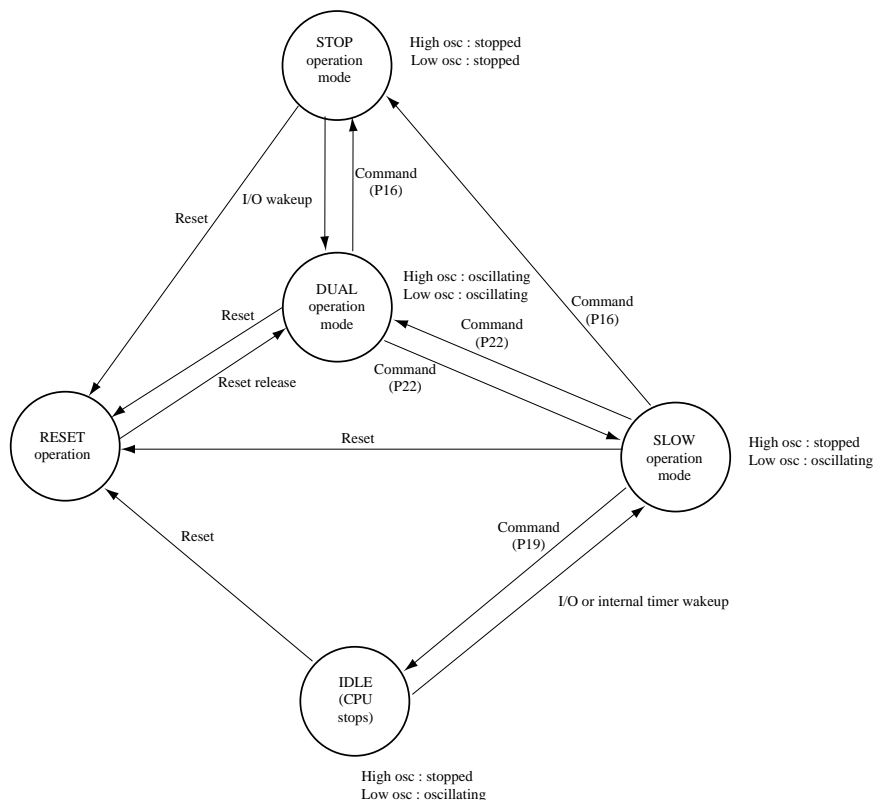

Operation Mode	Oscillator	System Clock	Available function	One instruction cycle
DUAL	High, Low frequency	High frequency clock	LCD, sound generator	8 / fc
SLOW	Low frequency	Low frequency clock	LCD	8 / fs
IDLE	Low frequency	CPU stops	LCD	-
STOP	None	CPU stops	All disable	-

**DUAL OPERATION MODE**

The 4-bit  $\mu$ c is in the DUAL operation mode when the CPU is reseted. This mode is dual clock system (high-frequency and low-frequency clocks oscillating). It can be changed to SLOW or STOP operation mode with the command register (P22 or P16).

LCD display and sound generator are available for the DUAL operation mode.

**SLOW OPERATION MODE**

The SLOW operation mode is single clock system (low-frequency clock oscillating). It can be changed to the DUAL operation mode with the command register (P22), STOP operation mode with P16 and IDEL operation mode with P19.

LCD display and sound generator are available for the SLOW operation mode.

**Preliminary**

P22      3      2      1      0      Initial value : 0000

*	SOM
---	-----

SOM	Select operation mode
0 0 0	DUAL operation mode
1 * *	SLOW operation mode

P14      3      2      1      0      Initial value : \*000

*	WKS	LFS	CPUS
---	-----	-----	------

LFS	Low-frequency status	CPUS	CPU status
0	LXIN source is not stable	0	DUAL operation mode
1	LXIN source is stable	1	SLOW operation mode

WKS	Wakeup status
0	Wakeup not by internal timer
1	Wakeup by internal timer

Port14 is the status register for CPU. P14.0 (CPU status) and P14.1 (Low-frequency status) are read-only bits. P14.2 (wakeup status) will be set as '1' when CPU is waked by internal timer. P14.2 will be cleared as '0' when user out data to P14.

### IDLE OPERATION MODE

The IDLE operation mode suspends all CPU functions except the low-frequency clock oscillation and the LCD driver. It keeps the internal status with low power consumption without stopping the slow clock oscillator and LCD display.

LCD display is available for the IDLE operation mode. Sound generator is disabled in this mode. The IDLE operation mode will be wakeup and return to the SLOW operation mode by the internal timing generator or I/O pins (P0(0..3)/WAKEUP 0..3 and P8(0..3)/WAKEUPA..D).

P19      3      2      1      0      Initial value : 0000

*	IDME	SIDR
---	------	------

IDME	Enable IDLE mode
1	Enable IDLE mode
0	no function

SIDR	Select IDLE releasing condition
0 0	P0(0..3), P8(0..3) pin input
0 1	P0(0..3), P8(0..3) pin input and 1 sec signal
1 0	P0(0..3), P8(0..3) pin input and 0.5 sec signal
1 1	P0(0..3), P8(0..3) pin input and 15.625 ms signal

### STOP OPERATION MODE

The STOP operation mode suspends system operation and holds the internal status immediately before the suspension with low power consumption. This mode will be released by reset or I/O pins (P0(0..3)/WAKEUP 0..3 and P8(0..3)/WAKEUP A..D).

LCD display and sound generator are disabled in the STOP operation mode.

**Preliminary**

P16    3    2    1    0                      Initial value : 0000

*	SPME	SWWT
---	------	------

SPME	Enable STOP mode
1	Enable STOP mode
0	no function

SWWT	Set wake-up warm-up time
0 0	$2^{18}/\text{CLK}$
0 1	$2^{14}/\text{CLK}$
1 0	$2^{16}/\text{CLK}$
1 1	no function

### TIME BASE INTERRUPT (TBI )

The time base can be used to generate a single fixed frequency interrupt . Eight types of frequencies can be selected with the "P25" setting.

P25    3    2    1    0                      initial value : 0000

P25	DUAL operation mode	SLOW operation mode
0 0 x x	Interrupt disable	Interrupt disable
0 1 0 0	Interrupt frequency LXIN / $2^3$ Hz	Reserved
0 1 0 1	Interrupt frequency LXIN / $2^4$ Hz	Reserved
0 1 1 0	Interrupt frequency LXIN / $2^5$ Hz	Reserved
0 1 1 1	Interrupt frequency LXIN / $2^{14}$ Hz	Interrupt frequency LXIN / $2^{14}$ Hz
1 1 0 0	Interrupt frequency LXIN / $2^1$ Hz	Reserved
1 1 0 1	Interrupt frequency LXIN / $2^6$ Hz	Interrupt frequency LXIN / $2^6$ Hz
1 1 1 0	Interrupt frequency LXIN / $2^8$ Hz	Interrupt frequency LXIN / $2^8$ Hz
1 1 1 1	Interrupt frequency LXIN / $2^{10}$ Hz	Interrupt frequency LXIN / $2^{10}$ Hz
1 0 x x	Reserved	Reserved

### TIMER / COUNTER ( TIMERA, TIMERB)

Timer/counters support three special functions:

1. Even counter
2. Timer.
3. Pulse-width measurement.

These three functions can be executed by 2 timer/counter independently.

With timerA, the counter data is saved in timer register TAH, TAM, TAL. User can set counter initial value and read the counter value by instruction "LDATAH(M,L)" and "STATAH(M,L)". With timer B register is TBH, TBM, TBL and the W/R instruction are "LDATBH (M,L)" and "STATBH (M,L)".

The basic structure of timer/counter is composed by two identical counter module , these two modules can be set initial timer or counter value to the timer registers, P28 and P29 are the command registers for timerA and timer B, user can choose different operation modes and internal clock rates by setting these two registers. When timer/counter overflows, it will generate a TRGA(B) interrupt request to interrupt control unit.



*Preliminary*

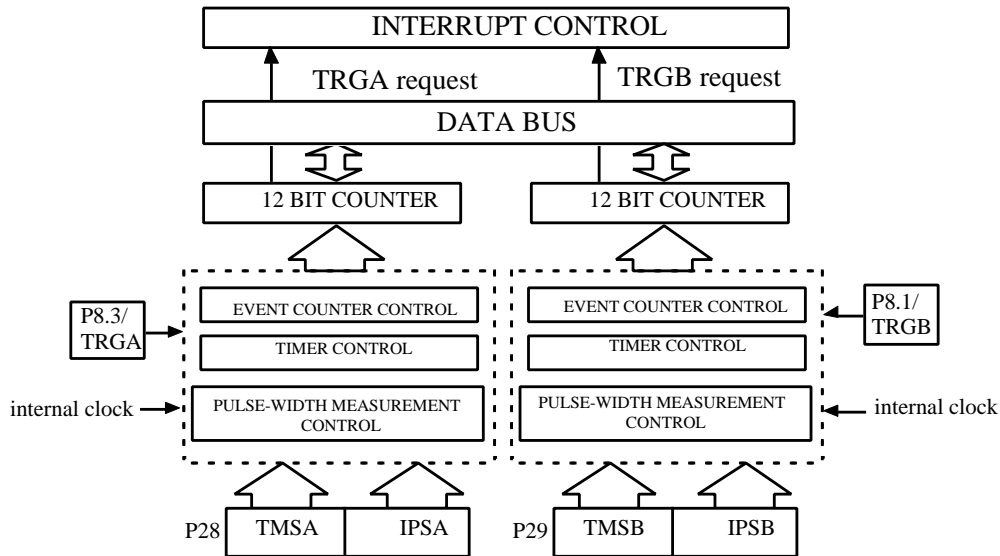

### TIMER/COUNTER CONTROL

P8.1/TRGB, P8.3/TRGA are the external timer inputs for timerB and timerA, they are used in event counter and pulse-width measurement mode.

Timer/counter command port: P28 is the command port for timer/counterA and P29 is for the timer/counterB.

Port 28		3 2 1 0		TIMER/COUNTER MODE SELECTION	
TMSA	IPSA			TMSA (B)	Function description
Initial state: 0000		0	0	0 0	Stop
		0	1	0 1	Event counter mode
		1	0	1 0	Timer mode
		1	1	1 1	Pulse width measurement mode

INTERNAL PULSE-RATE SELECTION		
IPSA(B)	DUAL mode	SLOW mode
0 0	$LXIN/2^3$ Hz	Reserved
0 1	$LXIN/2^7$ Hz	$LXIN/2^7$ Hz
1 0	$LXIN/2^{11}$ Hz	$LXIN/2^{11}$ Hz
1 1	$LXIN/2^{15}$ Hz	$LXIN/2^{15}$ Hz

**Preliminary**

## TIMER/COUNTER FUNCTION

Timer/counterA,B are programmable for timer, event counter and pulse width measurement mode. Each timer/counter can execute any of these functions independently.

### EVENT COUNTER MODE

under event counter mode, the timer/counter is increased by one at any rising edge of P8.1/TRGB for timerB (P8.3/TRGA for timer A). When timerB (timerA) counts overflow, it will provide an interrupt request TRGB (TRGA) to interrupt control unit.

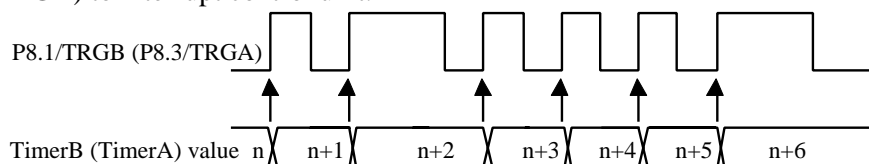

PROGRAM EXAMPLE: Enable timerA with P28

```
LDIA #0100b;
OUTA P28; Enable timerA with event counter mode
```

### TIMER MODE

Under timer mode ,the timer/counter is increased by one at any rising edge of internal pulse . User can choose up to 4 types of internal pulse rate by setting IPSB for timerB (IPSA for timerA).

When timer/counter counts overflow, An interrupt request will be sent to interrupt control unit.

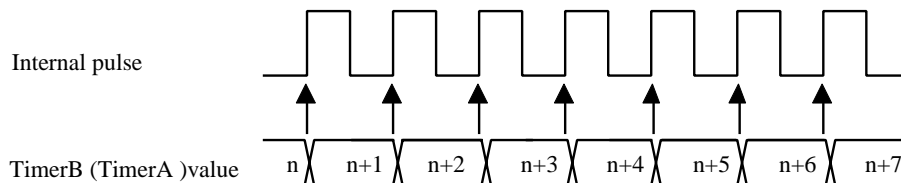

PROGRAM EXAMPLE: To generate TRGA interrupt request after 60 ms with system clock LXIN=32KHz

```
LDIA #0100B;
EXAE; enable mask 2
EICIL 110111b; interrupt latch ←0, enable EI
LDIA #0Ah;
STATAL;
LDIA #00h;
STATAM;
LDIA #0Fh;
STATAH;
LDIA #1000B;
OUTA P28; enable timerA with internal pulse rate: LXIN/23 Hz
```

NOTE: The preset value of timer/counter register is calculated as following procedure.

Internal pulse rate:  $LXIN/2^3$  ; LXIN = 32KHz

The time of timer counter count one =  $2^3 / LXIN = 8/32768=0.244ms$

The number of internal pulse to get timer overflow =  $60 ms / 0.244ms = 245.901= 0F6h$

The preset value of timer/counter register =  $1000h - 0F6h = F0Ah$

### PULSE WIDTH MEASUREMENT MODE

**Preliminary**

Under the pulse width measurement mode, the counter is increased at the rising edge of internal pulse during external timer/counter input (P8.1/TRGB, P8.3/TRGA ) in high level, interrupt request is generated as soon as timer/counter count overflow.

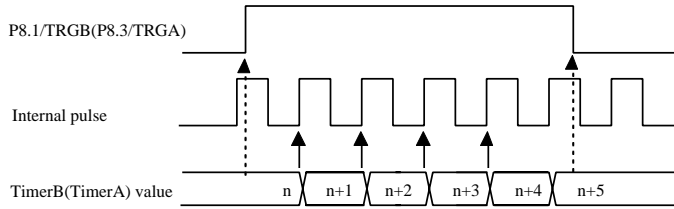

**PROGRAM EXAMPLE:** Enable timerA by pulse width measurement mode .  
LDIA #1100b;  
OUTA P28; Enable timerA with pulse width measurement mode.

### INTERRUPT FUNCTION

Five interrupt sources are available, 2 from external interrupt sources and 3 from internal interrupt sources . Multiple interrupts are admitted according to their priority .

Type	Interrupt source	Priority	Interrupt Latch	Interrupt Enable condition	Program ROM entry address
External	External interrupt( $\overline{INT0}$ )	1	IL5	EI=1	002h
Internal	Reserved	2	IL4	EI=1, MASK3=1	004h
Internal	TimerA overflow interrupt (TRGA)	3	IL3	EI=1, MASK2=1	006h
Internal	TimerB overflow interrupt (TRGB)	4	IL2	EI=1, MASK1=1	008h
Internal	Time base interrupt(TBI)	5	IL1		00Ah
External	External interrupt( $\overline{INT1}$ )	6	IL0	EI=1, MASK0=1	00Ch

### INTERRUPT STRUCTURE

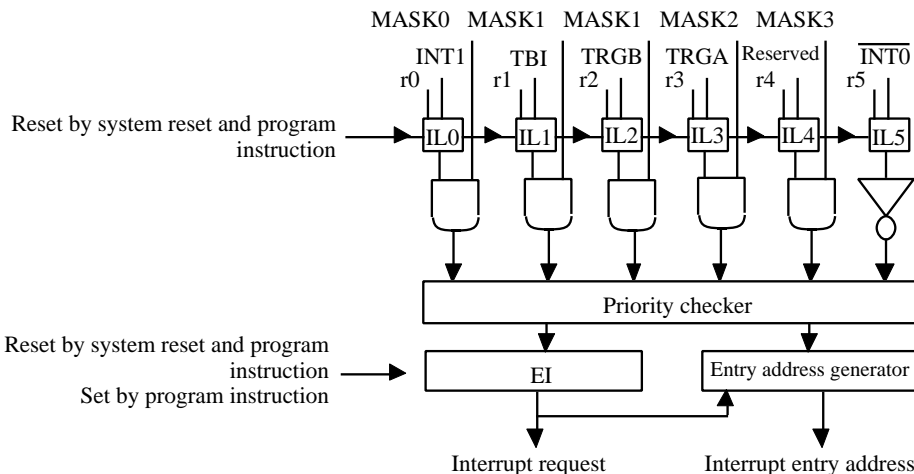

Interrupt controller:

IL0-IL5 : Interrupt latch . Hold all interrupt requests from all interrupt sources. IL's can not be set by program, but can be reset by program or system reset, so IL can only decide which interrupt source can be accepted.

MASK0-MASK3 : Except for  $\overline{INT0}$  ,MASK register may permit or inhibit all interrupt sources.

**Preliminary**

EI : Enable interrupt Flip-Flop may permit or inhibit all interrupt sources, when interrupt occurs, EI is auto cleared to "0", after RTI instruction is executed, EI is auto set to "1" again.

Priority checker : Check interrupt priority when multiple interrupts occur.

### INTERRUPT OPERATION

The procedure of interrupt operation:

1. Push PC and all flags to stack.
2. Set interrupt entry address into PC.
3. Set SF= 1.
4. Clear EI to inhibit other interrupts occur.
5. Clear the IL with which interrupt source has already been accepted.
6. Execute interrupt subroutine from the interrupt entry address.
7. CPU accept RTI, restore PC and flags from stack. Set EI to accept other interrupt requests.

PROGRAM EXAMPLE: To enable interrupt of "INT0, TRGA"

```
LDIA #0100B;
EXAE; set mask register "1100b"
EICIL 010111B ; enable interrupt F.F. and clear IL3 and IL5
```

### LCD DRIVER

It can directly drive the liquid crystal display ( LCD ) and has 40 segments, 16 commons output pins or 8 commons by music option. There are total 40x16 or 40x8 dots can be display.

#### (1) LCD driver command register:

Port27 3 2 1 0 Initial value: 0000

<b>LDC</b>	*	*
<b>LCD DISPLAY CONTROL</b>		
LDC	Function description	
0 0	LCD display disable	
0 1	Blanking	
1 0	no function	
1 1	LCD display enable	

\* : Don't care.

P27 is the LCD driver command register. The initial value is 0000.

When LDC ( bit2 and bit3 of P27 ) is set to "00", the LCD display is disabled.

When LDC is set to "01", the LCD is blanking, the COM pins are inactive and the SEG pins output the display data continuously.

When LDC is set to "11", the LCD display is enabled.

Under stop mode. LDC will be reset to "00".

#### (2) LCD display data area:

The LCD display data is stored in the display data area of the data memory ( RAM). The LCD display data area is as illustrated below:

*Preliminary*

The display data from the display data area are automatically read out and send to the LCD driver directly by the hardware. Therefore, the display patterns can be changed only by overwriting the contents of the display data area through software.

The display memory area that is not used to store the LCD display data could be used as the ordinary data memory.

**LCD display data area : (40x16 mode)**

**Bank1**

P9.3=1	0	1	2	3	4	5	6	7	8	9	A	B	C	D	E	F	
100-10Fh					COM0												
110-11Fh					COM1												
120-12Fh					COM2												
130-13Fh					COM3												
140-14					COM4												
150-15Fh					COM5												
160-16Fh					COM6												
170-17Fh					COM7												
180-18Fh					COM8												
190-19Fh					COM9												
1A0-1AFh					COM10												
1B0-1BFh					COM11												
1C0-1CFh					COM12												
1D0-1DFh					COM13												
1E0-1EFh					COM14												
1F0-1FFh					COM15												



P26 is the start address register of LCD common pin.

Port26      3   2   1   0      Initial value: 0000

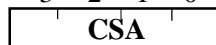

CSA	Common start address register															
	RAM															
	100-109h	110-119h	120-129h	130-139h	140-149h	150-159h	160-169h	170-179h	180-189h	190-199h	1A0-1A9h	1B0-1B9h	1C0-1C9h	1D0-1D9h	1E0-1E9h	1F0-1F9h
0000	COM0	COM1	COM2	COM3	COM4	COM5	COM6	COM7	COM8	COM9	COM10	COM11	COM12	COM13	COM14	COM15
0001	COM15	COM0	COM1	COM2	COM3	COM4	COM5	COM6	COM7	COM8	COM9	COM10	COM11	COM12	COM13	COM14
0010	COM14	COM15	COM0	COM1	COM2	COM3	COM4	COM5	COM6	COM7	COM8	COM9	COM10	COM11	COM12	COM13
0011	COM13	COM14	COM15	COM0	COM1	COM2	COM3	COM4	COM5	COM6	COM7	COM8	COM9	COM10	COM11	COM12
0100	COM12	COM13	COM14	COM15	COM0	COM1	COM2	COM3	COM4	COM5	COM6	COM7	COM8	COM9	COM10	COM11
0101	COM11	COM12	COM13	COM14	COM15	COM0	COM1	COM2	COM3	COM4	COM5	COM6	COM7	COM8	COM9	COM10
0110	COM10	COM11	COM12	COM13	COM14	COM15	COM0	COM1	COM2	COM3	COM4	COM5	COM6	COM7	COM8	COM9
0111	COM9	COM10	COM11	COM12	COM13	COM14	COM15	COM0	COM1	COM2	COM3	COM4	COM5	COM6	COM7	COM8
1000	COM8	COM9	COM10	COM11	COM12	COM13	COM14	COM15	COM0	COM1	COM2	COM3	COM4	COM5	COM6	COM7
1001	COM7	COM8	COM9	COM10	COM11	COM12	COM13	COM14	COM15	COM0	COM1	COM2	COM3	COM4	COM5	COM6
1010	COM6	COM7	COM8	COM9	COM10	COM11	COM12	COM13	COM14	COM15	COM0	COM1	COM2	COM3	COM4	COM5
1011	COM5	COM6	COM7	COM8	COM9	COM10	COM11	COM12	COM13	COM14	COM15	COM0	COM1	COM2	COM3	COM4
1100	COM4	COM5	COM6	COM7	COM8	COM9	COM10	COM11	COM12	COM13	COM14	COM15	COM0	COM1	COM2	COM3
1101	COM3	COM4	COM5	COM6	COM7	COM8	COM9	COM10	COM11	COM12	COM13	COM14	COM15	COM0	COM1	COM2
1110	COM2	COM3	COM4	COM5	COM6	COM7	COM8	COM9	COM10	COM11	COM12	COM13	COM14	COM15	COM0	COM1
1111	COM1	COM2	COM3	COM4	COM5	COM6	COM7	COM8	COM9	COM10	COM11	COM12	COM13	COM14	COM15	COM0

**Preliminary**

**LCD display data area : (40x8 mode)**

**Bank1**

P9.3=1	0	1	2	3	4	5	6	7	8	9	A	B	C	D	E	F	
100-10Fh						COM0											
110-11Fh						COM1											
120-12Fh						COM2											
130-13Fh						COM3											
140-14Fh						COM4											
150-15Fh						COM5											
160-16Fh						COM6											
170-17Fh						COM7											
180-18Fh																	
190-19Fh																	
1A0-1AFh																	
1B0-1BFh																	
1C0-1CFh																	
1D0-1DFh																	
1E0-1EFh																	
1F0-1FFh																	



P26 is the start address register of LCD common pin.

Port26      3   2   1   0      Initial value: 0000

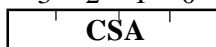

CSA	Common start address register															
	RAM															
	100-109h	110-119h	120-129h	130-139h	140-149h	150-159h	160-169h	170-179h	180-189h	190-199h	1A0-1A9h	1B0-1B9h	1C0-1C9h	1D0-1D9h	1E0-1E9h	1F0-1F9h
0000	COM0	COM1	COM2	COM3	COM4	COM5	COM6	COM7								
0001		COM0	COM1	COM2	COM3	COM4	COM5	COM6	COM7							
0010			COM0	COM1	COM2	COM3	COM4	COM5	COM6	COM7						
0011				COM0	COM1	COM2	COM3	COM4	COM5	COM6	COM7					
0100					COM0	COM1	COM2	COM3	COM4	COM5	COM6	COM7				
0101						COM0	COM1	COM2	COM3	COM4	COM5	COM6	COM7			
0110							COM0	COM1	COM2	COM3	COM4	COM5	COM6	COM7		
0111								COM0	COM1	COM2	COM3	COM4	COM5	COM6	COM7	
1000									COM0	COM1	COM2	COM3	COM4	COM5	COM6	COM7
1001	COM7									COM0	COM1	COM2	COM3	COM4	COM5	COM6
1010	COM6	COM7									COM0	COM1	COM2	COM3	COM4	COM5
1011	COM5	COM6	COM7									COM0	COM1	COM2	COM3	COM4
1100	COM4	COM5	COM6	COM7									COM0	COM1	COM2	COM3
1101	COM3	COM4	COM5	COM6	COM7									COM0	COM1	COM2
1110	COM2	COM3	COM4	COM5	COM6	COM7									COM0	COM1
1111	COM1	COM2	COM3	COM4	COM5	COM6	COM7									COM0

**PROGRAM EXAMPLE:**

```

LDIA    #0000B
OUTA    P26
LDIA    #1100B ; LCD display enable
OUTA    P27
LDIA    #1010B ; store 1010B to RAM[101h]
SEP     P9,3
STA     01H
    
```

**Preliminary**

**(3) LCD waveform : (1/5 bias)**

Although there are two LCD waveform types, but for the reason of the number of voltage transition point in type A is greater than type B, So type B gets a better display performance.

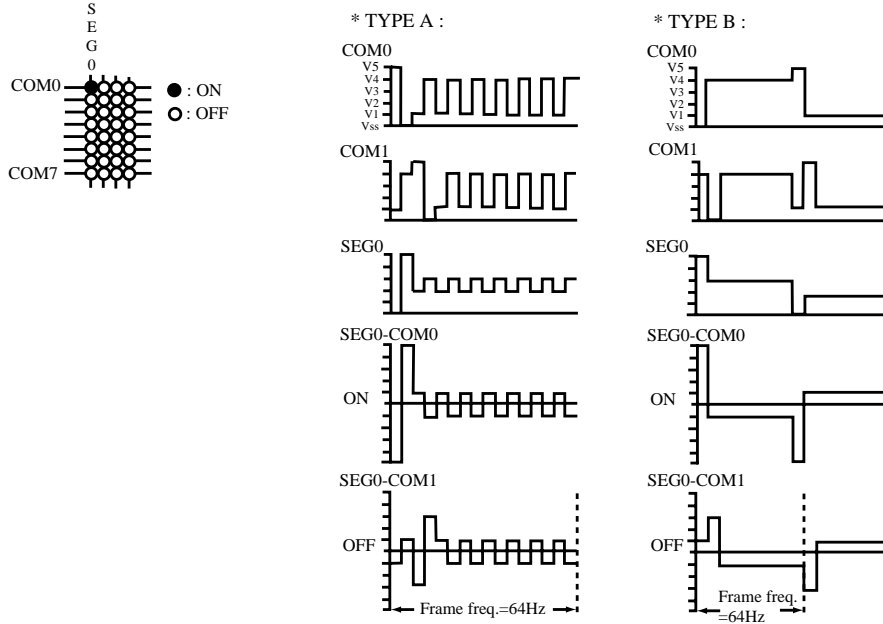

**(4) LCD bias resistor :**

There are high and low resistance choices for LCD bias resistor. To choose low bias resistor will take more power but get a better display performance.

**(5) LCD bias supply :**

The LCD bias voltage can be supplied by VDD or voltage multiplier, when the operating voltage of LCD panel and VDD are the same, the LCD bias voltage pin (V5) connects to VDD directly.

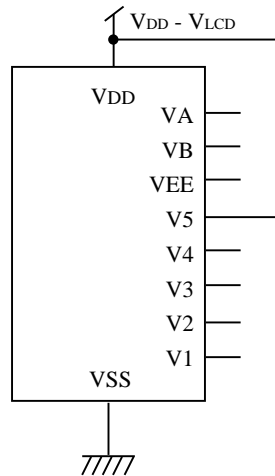

**Preliminary**

When the operating of LCD panel is higher than VDD, the LCD bias voltage is supplied by voltage multiplier. (C=C1=0.1μF) In the case of user chooses a large bias resistor or uses a large LCD panel, to connect 4 capacitors (C1) to V1~V4 can get a better display performance. Otherwise, you can open V1~V4 and ignore these 4 capacitors (C1).

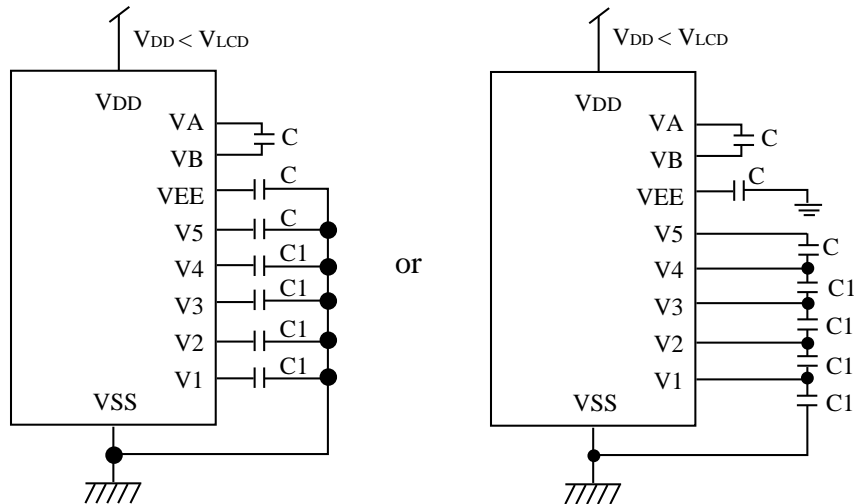

**SOUND EFFECT**

EM73C63 has a built-in sound effect generator. It includes the tone generator, random generator and volume control. The tone generator is a binary down counter and random generator is a 9-bit linear feedback shift register. The sound generator is available for the DUAL operation mode only. When the CPU is reseted or in the SLOW, IDLE, or STOP operation mode, the sound generator is disable and the P4.0/SOUND is in high state and SOUND is in low state.

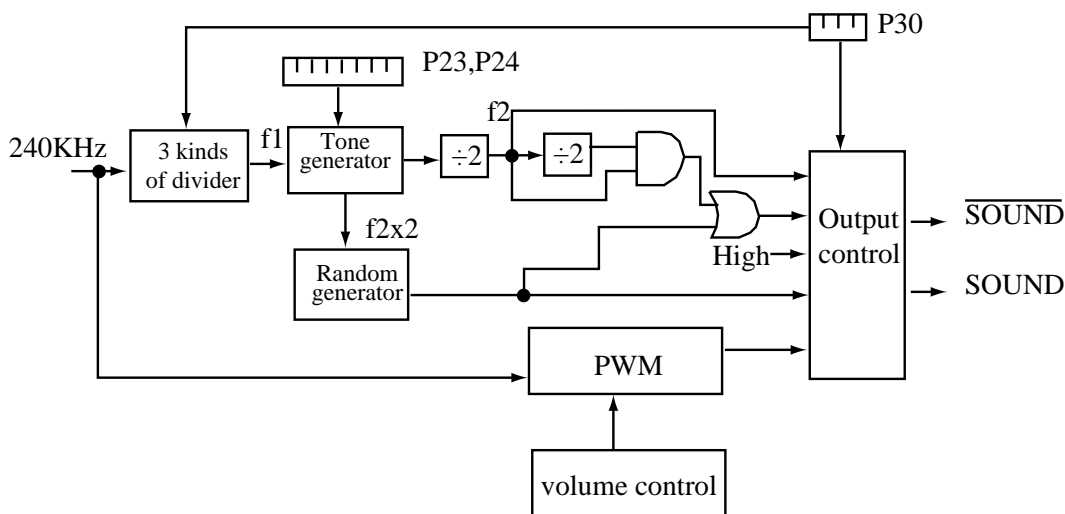



Preliminary

Sound generator command register

Three basic frequencies for sound generator can be selected by P30. The output of sound effect generator can be tone, random tone or both combination.

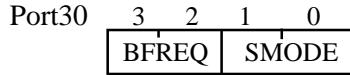

Initial value : 0000

BFREQ	Basic frequency (f1) select
0 0	240 KHz
0 1	120 KHz
1 0	60 KHz
1 1	don't care

SMODE	Sound generator mode
0 0	Disable
0 1	Tone output
1 0	Random output
1 1	Tone+random output

Tone frequency register

The 8-bit tone frequency register (TF) is P24 and P23. The tone frequency is changed when user output the different data to P24 and P23.

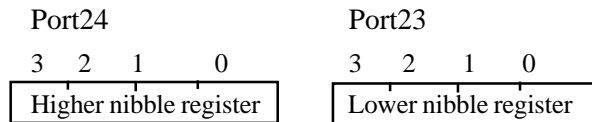

Initial value : 1111 1111

\*\*  $f1=240K/2^x$ ,  $f2=f1/(TF+1)/2$ ,  $TF=1\sim255$ ,  $TF\neq0$

\*\* Example : BFREQ=10, TF=00110001B.

$\Rightarrow f1=60KHz, f2=60KHz/50/2=600Hz$

Random generator

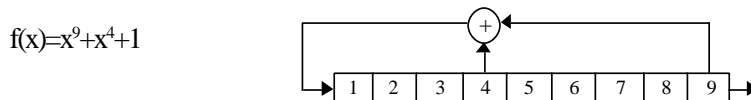

Volume control register

The are 8 volume levels for sound generator. P17 is the volume control register.

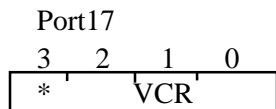

Initial value : \* 111

VCR			ts/tp
1	1	1	8/8
1	1	0	7/8
1	0	1	6/8
1	0	0	5/8
0	1	1	4/8
0	1	0	3/8
0	0	1	2/8
0	0	0	1/8

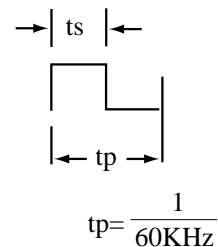

**Preliminary**

**PROGRAM EXAMPLE:**

```
LDIA    #0011B ; volume control
OUTA    P17
LDIA    #0011B ; 600 Hz tone output
OUTA    P24
LDIA    #0001B
OUTA    P23
LDIA    #1001B ; basic frequency : 60 KHz tone output
OUTA    P30
```

**RESETTING FUNCTION**

While CPU in normal working condition and  $\overline{\text{RESET}}$  pin is held in low level for three instruction cycles at least, then CPU begins to initialize the whole internal states, when  $\overline{\text{RESET}}$  pin changes to high level, CPU begins to work in normal condition.

The CPU internal state during reset condition is as following table :

Hardware condition in RESET state	Initial value
Program counter	0000h
Status flag	01h
Interrupt enable flip-flop ( EI )	00h
MASK0 ,1, 2, 3	00h
Interrupt latch ( IL )	00h
P3, 9, 14, 16, 17, 19, 22,25, 26, 27, 28, 29, 30	00h
P4, 8, 17, 23, 24	0Fh
CLK, LXIN	Start oscillation

The  $\overline{\text{RESET}}$  pin is a hysteresis input pin and it has a pull-up resistor available by mask option. The simplest RESET circuit is connect RESET pin with a capacitor to  $V_{SS}$  and a diode to  $V_{DD}$ .

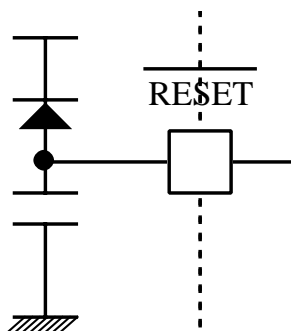

*Preliminary*

APPLICATION CIRCUIT

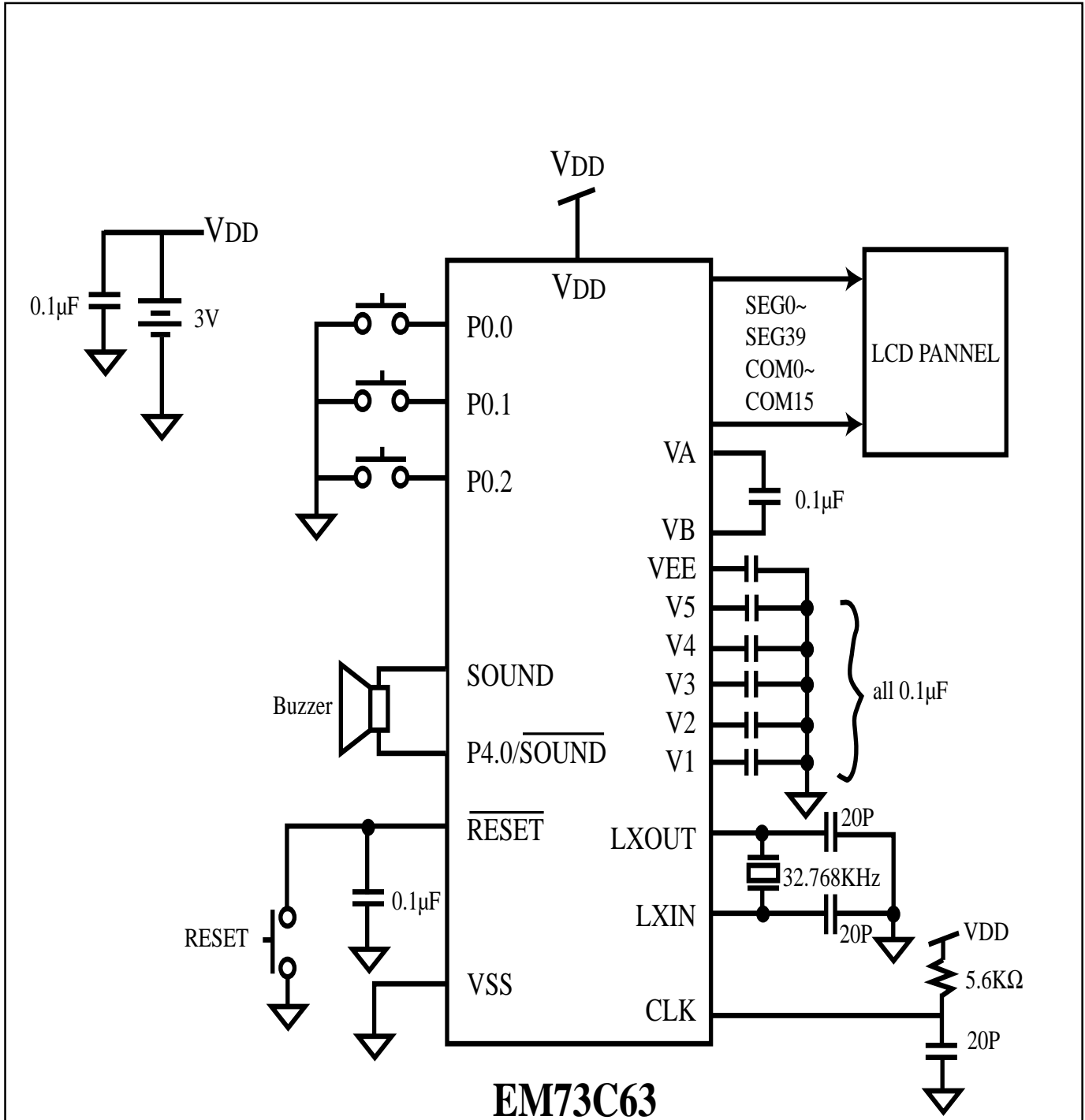

**EM73C63**

Note : This application circuit (RC) is designed for  $f_c=4\text{MHz}$ .

**Preliminary**

**EM73C63 I/O PORT DESCRIPTION :**

Port	Input function	Output function	Note
0	E Input port , wakeup function		
1	--	--	
2	--	--	
3	--	I P3(0..2) : ROM bank selection	
4	E Input port	E Output port, P4.0/SOUND	
5	--	--	
6	--	--	
7	--	--	
8	E Input port, wakeup function, external interrupt input	E Output port	
9	--	I P9.3 : RAM bank selection	
10	--	--	
11	--	--	
12	--	--	
13	--	--	
14	I CPU status register	--	
15	--	--	
16		I STOP mode control register	
17		I Sound effect volume control register	
18		--	
19		I IDLE mode control register	
20		--	
21		I DUAL/SLOW mode control register	
22		I Slow/Normal mode control register	
23		I Sound effect frequency register	low nibble
24		I Sound effect frequency register	high nibble
25		I Timebase control register	
26		I LCD common start address register	
27		I LCD control register	
28		I Timer/counter A control register	
29		I Timer/counter B control register	
30		I Sound effect command register	
31		--	

Preliminary

### ABSOLUTE MAXIMUM RATINGS

Items	Sym.	Ratings	Conditions
Supply Voltage	$V_{DD}$	-0.5V to 6V	
Input Voltage	$V_{IN}$	-0.5V to $V_{DD}+0.5V$	
Output Voltage	$V_O$	-0.5V to $V_{DD}+0.5V$	
Power Dissipation	$P_D$	300mW	$T_{OPR}=50^{\circ}C$
Operating Temperature	$T_{OPR}$	0°C to 50°C	
Storage Temperature	$T_{STG}$	-55°C to 125°C	

### RECOMMENDED OPERATING CONDITIONS

Items	Sym.	Ratings	Condition
Supply Voltage	$V_{DD}$	2.4V to 3.6V	
Input Voltage	$V_{IH}$	$0.90 \times V_{DD}$ to $V_{DD}$	
	$V_{IL}$	0V to $0.10 \times V_{DD}$	
Operating Frequency	$F_C$	480K to 4MHz	CLK (RC osc)
	$F_S$	32KHz	LXIN,LXOUT (crystal/RC osc)

### DC ELECTRICAL CHARACTERISTICS ( $V_{DD}=3 \pm 0.3V$ , $V_{SS}=0V$ , $T_{OPR}=25^{\circ}C$ )

Parameters	Sym.	Min.	Typ.	Max.	Unit	Conditions
Supply current	$I_{DD}$	-	0.9	2	mA	$V_{DD}=3.3V$ , no load, NORMAL mode, $F_S=32KHz$ $F_C=4MHz$ (RC osc : $R=6.2K\Omega$ , $C=20pF$ )
		-	25	40	$\mu A$	$V_{DD}=3.3V$ , no load, SLOW mode, $F_S=32KHz$ LCD on
		-	6	10	$\mu A$	$V_{DD}=3.3V$ , IDLE mode, LCD off
		-	0.1	1	$\mu A$	$V_{DD}=3.3V$ , STOP mode
Hysteresis voltage	$V_{HYS+}$	$0.50V_{DD}$	-	$0.75V_{DD}$	V	RESET, P0, P8
	$V_{HYS-}$	$0.20V_{DD}$	-	$0.40V_{DD}$	V	
Input current	$I_{IH}$	-	-	$\pm 1$	$\mu A$	P0, RESET, $V_{DD}=3.3V$ , $V_{IH}=3.3/0V$
		-	-	$\pm 1$	$\mu A$	Open-drain, $V_{DD}=3.3V$ , $V_{IH}=3.3/0V$
	$I_{IL}$	-	-250	-500	$\mu A$	Push-pull, $V_{DD}=3.3V$ , $V_{IL}=0.4V$ , except P4
Output voltage	$V_{OH}$	2.4	-	-	V	Push-pull, P4(high current PMOS), SOUND, $V_{DD}=2.7V$ , $I_{OH}=-1.57mA$
		2.0	2.4	-	V	Push-pull, P4(low current PMOS), P8, $V_{DD}=2.7V$ , $I_{OH}=-166\mu A$
	$V_{OL}$	-	0.15	0.3	V	$V_{DD}=2.7V$ , $I_{OL}=1.5mA$
Leakage current	$I_{LO}$	-	-	1	$\mu A$	Open-drain, $V_{DD}=3.3V$ , $V_O=3.3V$
Input resistor	$R_{IN}$	100	200	300	K $\Omega$	P0
		300	600	900	K $\Omega$	RESET
Frequency stability		-	15	-	%	$F_C=4MHz$ , RC osc, $[F(3V)-F(2.4V)]/F(3V)$
Frequency variation		-	20	-	%	$F_C=4MHz$ , $V_{DD}=3V$ , RC osc, $[F(\text{typical})-F(\text{worse case})]/F(\text{typical})$

Preliminary

**DC ELECTRICAL CHARACTERISTICS** ( $V_{DD}=4.5\pm 0.5V$ ,  $V_{SS}=0V$ ,  $T_{OPR}=25^{\circ}C$ )

Parameters	Sym.	Min.	Typ.	Max.	Unit	Conditions
Supply current	$I_{DD}$	-	1.5	2.5	mA	$V_{DD}=5.0V$ , no load, NORMAL mode, $F_s=32KHz$ $F_c=4MHz$ (RC osc : $R=6.2K\Omega$ , $C=20pF$ )
		-	60	100	$\mu A$	$V_{DD}=5.0V$ , no load, SLOW mode, $F_s=32KHz$ LCD on
		-	15	20	$\mu A$	$V_{DD}=5.0V$ , IDLE mode, LCD off
		-	0.1	1	$\mu A$	$V_{DD}=5.0V$ , STOP mode
Hysteresis voltage	$V_{HYS+}$	$0.50V_{DD}$	-	$0.75V_{DD}$	V	RESET, P0, P8
	$V_{HYS-}$	$0.20V_{DD}$	-	$0.40V_{DD}$	V	
Input current	$I_{IH}$	-	-	$\pm 1$	$\mu A$	P0, RESET, $V_{DD}=4.5V$ , $V_{IH}=4.5V$
		-	-	$\pm 1$	$\mu A$	Open-drain, $V_{DD}=4.5V$ , $V_{IH}=4.5V$
	$I_{IL}$	-	-250	-500	$\mu A$	Push-pull, $V_{DD}=5.0V$ , $V_{IL}=0.4V$ , except P4
Output voltage	$V_{OH}$	2.4	-	-	V	Push-pull, P4(high current PMOS), SOUND, $V_{DD}=4.0V$ , $I_{OH}=-7.5mA$
		2.0	2.4	-	V	Push-pull, P4(low current PMOS), P8, $V_{DD}=4.0V$ , $I_{OH}=-470\mu A$
	$V_{OL}$	-	0.15	0.4	V	$V_{DD}=4.0V$ , $I_{OL}=7mA$
Leakage current	$I_{LO}$	-	-	1	$\mu A$	Open-drain, $V_{DD}=3.3V$ , $V_o=3.3V$
Input resistor	$R_{IN}$	100	200	300	$K\Omega$	P0
		300	600	900	$K\Omega$	RESET
Frequency stability		-	15	-	%	$F_c=4MHz$ , RC osc, $[F(3V)-F(2.4V)]/F(3V)$
Frequency variation		-	20	-	%	$F_c=4MHz$ , $V_{DD}=3V$ , RC osc, $[F(\text{typical})-F(\text{worse case})]/F(\text{typical})$

**Preliminary**

**RESET PIN TYPE**

TYPE RESET-A

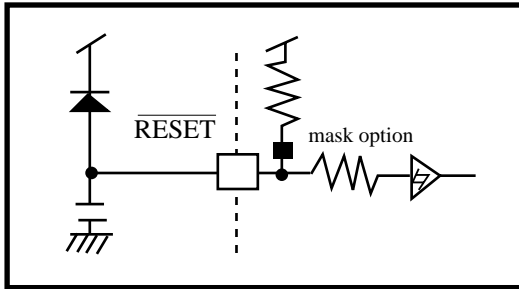

**OSCILLATION PIN TYPE**

TYPE OSC-B

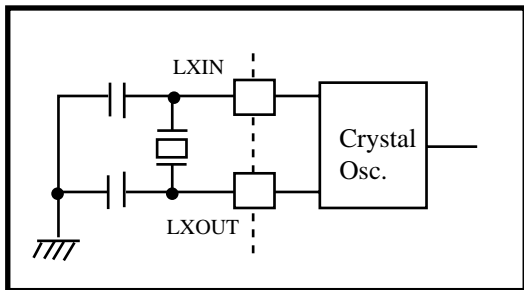

TYPE OSC-C

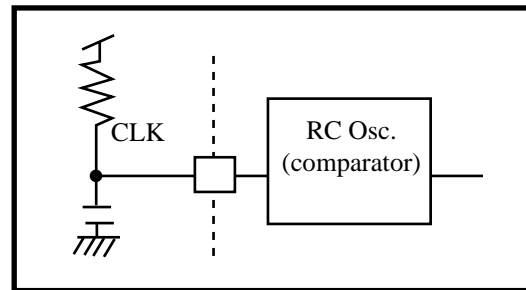

**TYPE OSC-F**

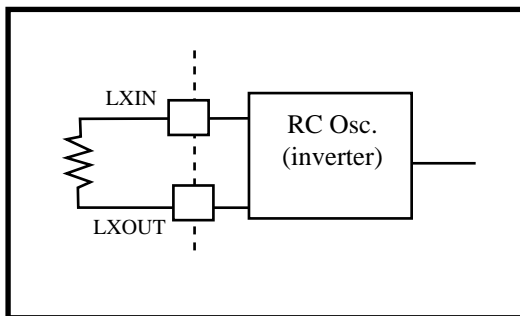

**INPUT PIN TYPE**

TYPE INPUT-A

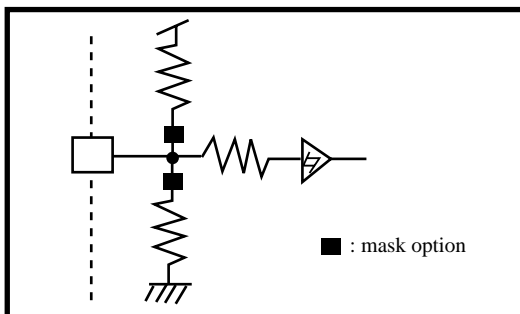

TYPE INPUT-B

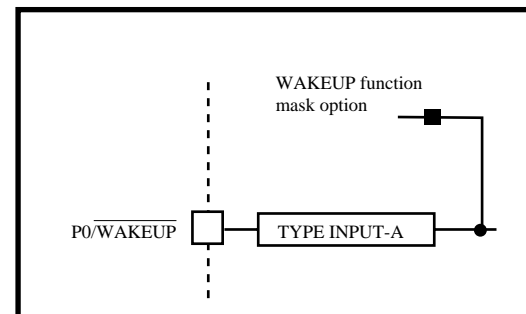

**Preliminary**

**I/O PIN TYPE**

**TYPE I/O**

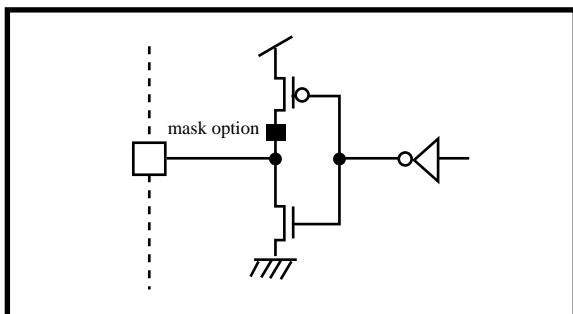

**TYPE I/O-L**

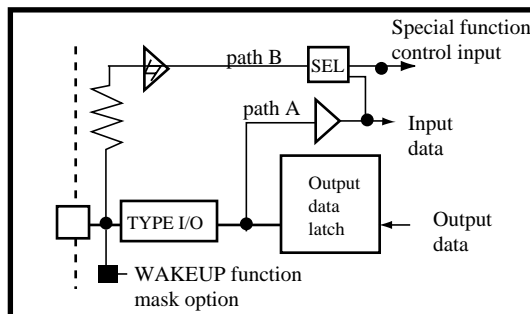

**TYPE I/O-N**

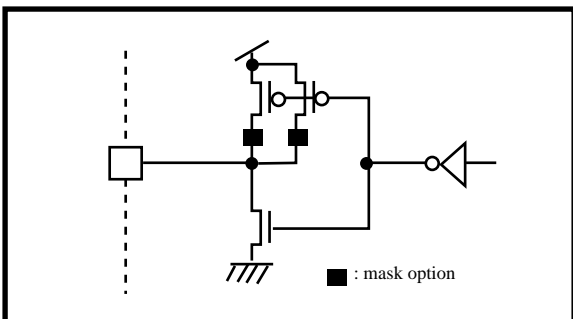

**TYPE I/O-O**

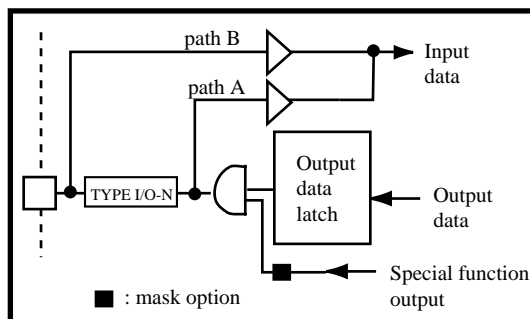

Path A : For set and clear bit of port instructions, data goes through path A from output data latch to CPU.  
 Path B : For input and test instructions, data from output pin go through path B to CPU and the output data latch will be set to high.



*Preliminary*

**PAD DIAGRAM**

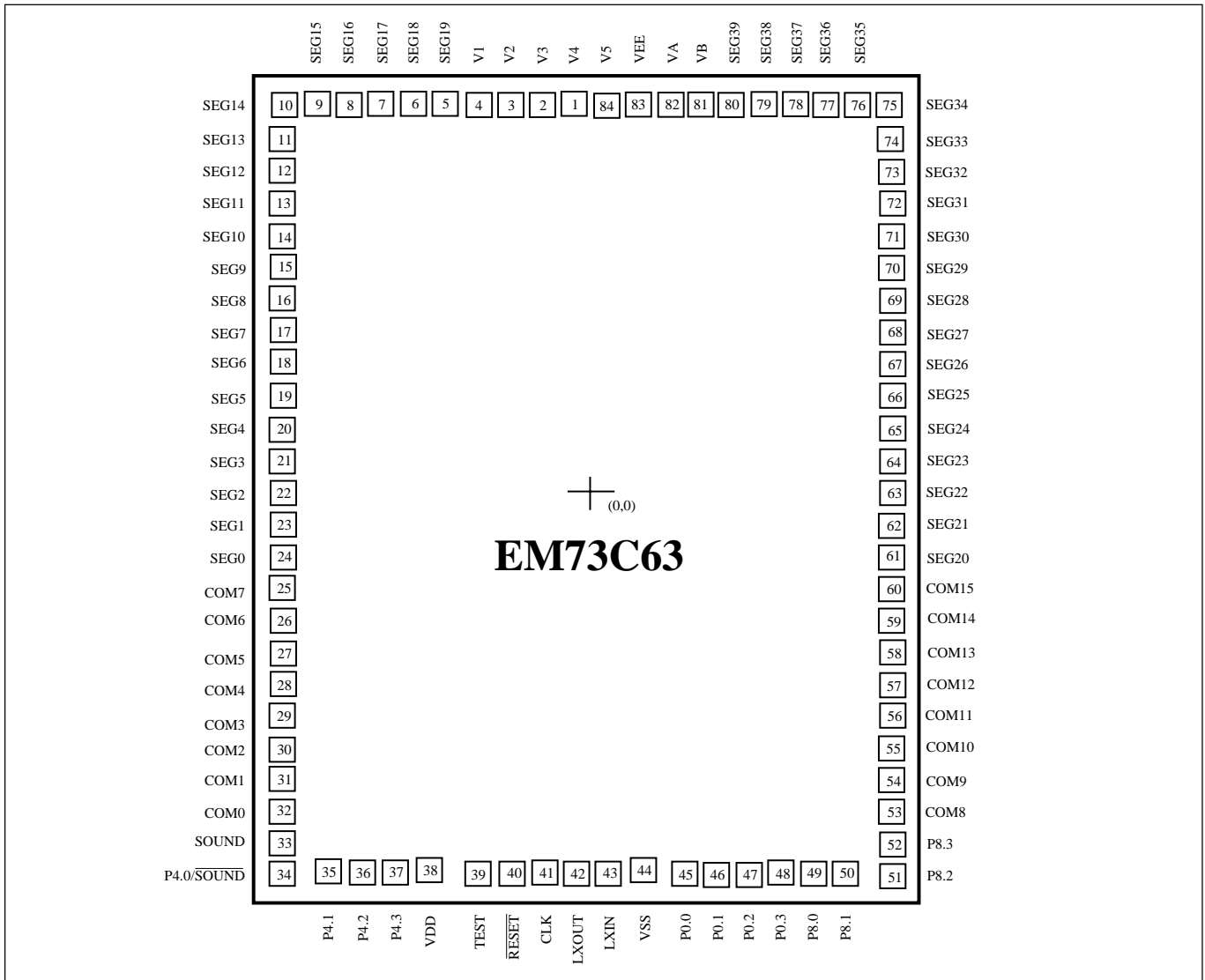

Pad No.	Symbol	X	Y
1	V4	-59.1	1438.1
2	V3	-179.0	1438.1
3	V2	-298.9	1438.1
4	V1	-418.8	1438.1
5	SEG19	-538.7	1438.1
6	SEG18	-658.6	1438.1
7	SEG17	-778.5	1438.1
8	SEG16	-898.4	1438.1
9	SEG15	-1018.3	1438.1
10	SEG14	-1138.2	1438.1
11	SEG13	-1146.4	1310.5
12	SEG12	-1146.4	1190.6

\* This specification are subject to be changed without notice.



**Preliminary**

Pad No.	Symbol	X	Y
13	SEG11	-1146.4	1070.7
14	SEG10	-1146.4	950.8
15	SEG9	-1146.4	830.9
16	SEG8	-1146.4	711.0
17	SEG7	-1146.4	591.1
18	SEG6	-1146.4	471.2
19	SEG5	-1146.4	351.3
20	SEG4	-1146.4	231.4
21	SEG3	-1146.4	111.5
22	SEG2	-1146.4	-8.4
23	SEG1	-1146.4	-128.3
24	SEG0	-1146.4	-248.2
25	COM7	-1146.4	-368.1
26	COM6	-1146.4	-488.0
27	COM5	-1146.4	-607.9
28	COM4	-1146.4	-727.8
29	COM3	-1146.4	-847.7
30	$\overline{\text{COM2}}$	-1146.4	-967.6
31	COM1	-1146.4	-1087.5
32	COM0	-1146.4	-1207.4
33	SOUND	-1145.5	-1328.9
34	P4.0/SOUND	-1145.5	-1450.4
35	P4.1	-967.9	-1435.5
36	P4.2	-846.3	-1435.5
37	P4.3	-723.1	-1435.5
38	VDD	-598.8	-1419.7
39	TEST	-410.9	-1436.4
40	RESET	-291.0	-1436.4
41	CLK	-169.5	-1436.4
42	LXOUT	-49.6	-1436.4
43	LXIN	70.3	-1436.4
44	VSS	202.1	-1421.4
45	P0.0	361.5	-1436.4
46	P0.1	481.4	-1436.4
47	P0.2	604.4	-1436.4
48	P0.3	724.3	-1436.4
49	P8.0	847.2	-1436.4
50	P8.1	967.1	-1436.4
51	P8.2	1148.5	-1450.3
52	P8.3	1148.5	-1327.3

\* This specification are subject to be changed without notice.



**Preliminary**

Pad No.	Symbol	X	Y
53	COM8	1148.5	-207.4
54	COM9	1148.5	-1087.5
55	COM10	1148.5	-967.6
56	COM11	1148.5	-847.7
57	COM12	1148.5	-727.8
58	COM13	1148.5	-607.9
59	COM14	1148.5	-488.0
60	COM15	1148.5	-368.1
61	SEG20	1148.5	-248.2
62	SEG21	1148.5	-128.3
63	SEG22	1148.5	-8.4
64	SEG23	1148.5	111.5
65	SEG24	1148.5	231.4
66	SEG25	1148.5	351.3
67	SEG26	1148.5	471.2
68	SEG27	1148.5	591.1
69	SEG28	1148.5	711.0
70	SEG29	1148.5	830.9
71	SEG30	1148.5	950.8
72	SEG31	1148.5	1070.7
73	SEG32	1148.5	1190.6
74	SEG33	1148.5	1310.5
75	SEG34	1139.9	1438.1
76	SEG35	1020.0	1438.1
77	SEG36	900.1	1438.1
78	SEG37	780.2	1438.1
79	SEG38	660.3	1438.1
80	SEG39	540.4	1438.1
81	VB	420.5	1438.1
82	VA	300.6	1438.1
83	VEE	180.7	1438.1
84	V5	60.8	1438.1

Unit:  $\mu\text{m}$

Chip Size: 2680x3260  $\mu\text{m}$

Note : For PCB layout, IC substrate must be floated or connect to  $V_{SS}$ .

Preliminary

## INSTRUCTION TABLE

### (1) Data Transfer

Mnemonic	Object code ( binary )	Operation description	Byte	Cycle	Flag		
					C	Z	S
LDA x	0110 1010 xxxx xxxx	Acc←RAM[x]	2	2	-	Z	1
LDAM	0101 1010	Acc←RAM[HL]	1	1	-	Z	1
LDAX	0110 0101	Acc←ROM[DP] <sub>L</sub>	1	2	-	Z	1
LDAXI	0110 0111	Acc←ROM[DP] <sub>H</sub> ,DP+1	1	2	-	Z	1
LDH #k	1001 kkkk	HR←k	1	1	-	-	1
LDHL x	0100 1110 xxxx xx00	LR←RAM[x],HR←RAM[x+1]	2	2	-	-	1
LDIA #k	1101 kkkk	Acc←k	1	1	-	Z	1
LDL #k	1000 kkkk	LR←k	1	1	-	-	1
STA x	0110 1001 xxxx xxxx	RAM[x]←Acc	2	2	-	-	1
STAM	0101 1001	RAM[HL]←Acc	1	1	-	-	1
STAMD	0111 1101	RAM[HL]←Acc, LR-1	1	1	-	Z	C
STAMI	0111 1111	RAM[HL]←Acc, LR+1	1	1	-	Z	C'
STD #k,y	0100 1000 kkkk yyyy	RAM[y]←k	2	2	-	-	1
STDMI #k	1010 kkkk	RAM[HL]←k, LR+1	1	1	-	Z	C'
THA	0111 0110	Acc←HR	1	1	-	Z	1
TLA	0111 0100	Acc←LR	1	1	-	Z	1

### (2) Rotate

Mnemonic	Object code ( binary )	Operation description	Byte	Cycle	Flag		
					C	Z	S
RLCA	0101 0000	←CF←Acc←1	1	1	C	Z	C'
RRCA	0101 0001	1→CF→Acc→	1	1	C	Z	C'

### (3) Arithmetic operation

Mnemonic	Object code ( binary )	Operation description	Byte	Cycle	Flag		
					C	Z	S
ADCAM	0111 0000	Acc←Acc + RAM[HL] + CF	1	1	C	Z	C'
ADD #k,y	0100 1001 kkkk yyyy	RAM[y]←RAM[y] +k	2	2	-	Z	C'
ADDA #k	0110 1110 0101 kkkk	Acc←Acc+k	2	2	-	Z	C'
ADDAM	0111 0001	Acc←Acc + RAM[HL]	1	1	-	Z	C'
ADDH #k	0110 1110 1001 kkkk	HR←HR+k	2	2	-	Z	C'
ADDL #k	0110 1110 0001 kkkk	LR←LR+k	2	2	-	Z	C'
ADDM #k	0110 1110 1101 kkkk	RAM[HL]←RAM[HL] +k	2	2	-	Z	C'
DECA	0101 1100	Acc←Acc-1	1	1	-	Z	C
DECL	0111 1100	LR←LR-1	1	1	-	Z	C
DECM	0101 1101	RAM[HL]←RAM[HL] -1	1	1	-	Z	C
INCA	0101 1110	Acc←Acc + 1	1	1	-	Z	C'

Preliminary

INCL	0111 1110	LR←LR + 1	1	1	-	Z	C'
INCM	0101 1111	RAM[HL]←RAM[HL]+1	1	1	-	Z	C'
SUBA #k	0110 1110 0111 kkkk	Acc←k-Acc	2	2	-	Z	C
SBCAM	0111 0010	Acc←RAM[HL] - Acc - CF'	1	1	C	Z	C
SUBM #k	0110 1110 1111 kkkk	RAM[HL]←k - RAM[HL]	2	2	-	Z	C

**(4) Logical operation**

Mnemonic	Object code ( binary )	Operation description	Byte	Cycle	Flag		
					C	Z	S
ANDA #k	0110 1110 0110 kkkk	Acc←Acc&k	2	2	-	Z	Z'
ANDAM	0111 1011	Acc←Acc & RAM[HL]	1	1	-	Z	Z'
ANDM #k	0110 1110 1110 kkkk	RAM[HL]←RAM[HL]&k	2	2	-	Z	Z'
ORA #k	0110 1110 0100 kkkk	Acc←Acc   k	2	2	-	Z	Z'
ORAM	0111 1000	Acc ←Acc   RAM[HL]	1	1	-	Z	Z'
ORM #k	0110 1110 1100 kkkk	RAM[HL]←RAM[HL]   k	2	2	-	Z	Z'
XORAM	0111 1001	Acc←Acc^RAM[HL]	1	1	-	Z	Z'

**(5) Exchange**

Mnemonic	Object code ( binary )	Operation description	Byte	Cycle	Flag		
					C	Z	S
EXA x	0110 1000 xxxx xxxx	Acc↔RAM[x]	2	2	-	Z	1
EXAH	0110 0110	Acc↔HR	1	2	-	Z	1
EXAL	0110 0100	Acc↔LR	1	2	-	Z	1
EXAM	0101 1000	Acc↔RAM[HL]	1	1	-	Z	1
EXHL x	0100 1100 xxxx xx00	LR↔RAM[x], HR↔RAM[x+1]	2	2	-	-	1

**(6) Branch**

Mnemonic	Object code ( binary )	Operation description	Byte	Cycle	Flag		
					C	Z	S
SBR a	00aa aaaa	If SF=1 then PC←PC <sub>12-6</sub> .a <sub>5-0</sub> else null	1	1	-	-	1
LBR a	1100 aaaa aaaa aaaa	If SF= 1 then PC←a else null	2	2	-	-	1
SLBR a	0101 0101 1100 aaaa aaaa aaaa (a:1000~1FFFh) 0101 0111 1100 aaaa aaaa aaaa (a:0000~0FFFh)	If SF=1 then PC←a else null	3	3	-	-	1

**(7) Compare**

Mnemonic	Object code ( binary )	Operation description	Byte	Cycle	Flag		
					C	Z	S
CMP #k,y	0100 1011 kkkk yyyy	k-RAM[y]	2	2	C	Z	Z'
CMPA x	0110 1011 xxxx xxxx	RAM[x]-Acc	2	2	C	Z	Z'

\* This specification are subject to be changed without notice.

Preliminary

Mnemonic	Object code ( binary )	Operation description	Byte	Cycle	Flag		
					C	Z	S
CMPAM	0111 0011	RAM[HL] <sub>b</sub> - Acc	1	1	C	Z	Z'
CMPH #k	0110 1110 1011 kkkk	k - HR	2	2	-	Z	C
CMPIA #k	1011 kkkk	k - Acc	1	1	C	Z	Z'
CMPL #k	0110 1110 0011 kkkk	k-LR	2	2	-	Z	C

**(8) Bit manipulation**

Mnemonic	Object code ( binary )	Operation description	Byte	Cycle	Flag		
					C	Z	S
CLM b	1111 00bb	RAM[HL] <sub>b</sub> ← 0	1	1	-	-	1
CLP p,b	0110 1101 11bb pppp	PORT[p] <sub>b</sub> ← 0	2	2	-	-	1
CLPL	0110 0000	PORT[LR <sub>3-2</sub> +4]LR <sub>1-0</sub> ← 0	1	2	-	-	1
CLR y,b	0110 1100 11bb yyyy	RAM[y] <sub>b</sub> ← 0	2	2	-	-	1
SEM b	1111 01bb	RAM[HL] <sub>b</sub> ← 1	1	1	-	-	1
SEP p,b	0110 1101 01bb pppp	PORT[p] <sub>b</sub> ← 1	2	2	-	-	1
SEPL	0110 0010	PORT[LR <sub>3-2</sub> +4]LR <sub>1-0</sub> ← 1	1	2	-	-	1
SET y,b	0110 1100 01bb yyyy	RAM[y] <sub>b</sub> ← 1	2	2	-	-	1
TF y,b	0110 1100 00bb yyyy	SF ← RAM[y] <sub>b</sub> '	2	2	-	-	*
TFA b	1111 10bb	SF ← Acc <sub>b</sub> '	1	1	-	-	*
TFM b	1111 11bb	SF ← RAM[HL] <sub>b</sub> '	1	1	-	-	*
TFP p,b	0110 1101 00bb pppp	SF ← PORT[p] <sub>b</sub> '	2	2	-	-	*
TFPL	0110 0001	SF ← PORT[LR <sub>3-2</sub> +4]LR <sub>1-0</sub> '	1	2	-	-	*
TT y,b	0110 1100 10bb yyyy	SF ← RAM[y] <sub>b</sub>	2	2	-	-	*
TTP p,b	0110 1101 10bb pppp	SF ← PORT[p] <sub>b</sub>	2	2	-	-	*

**(9) Subroutine**

Mnemonic	Object code ( binary )	Operation description	Byte	Cycle	Flag		
					C	Z	S
LCALL a	0100 0aaa aaaa aaaa	STACK[SP] ← PC, SP ← SP - 1, PC ← a	2	2	-	-	-
SCALL a	1110 nnnn	STACK[SP] ← PC, SP ← SP - 1, PC ← a, a = 8n + 6 (n = 1~15), 0086h (n = 0)	1	2	-	-	-
RET	0100 1111	SP ← SP + 1, PC ← STACK[SP]	1	2	-	-	-

**(10) Input/output**

Mnemonic	Object code ( binary )	Operation description	Byte	Cycle	Flag		
					C	Z	S
INA p	0110 1111 0100 pppp	Acc ← PORT[p]	2	2	-	Z	Z'
INM p	0110 1111 1100 pppp	RAM[HL] ← PORT[p]	2	2	-	-	Z'
OUT #k,p	0100 1010 kkkk pppp	PORT[p] ← k	2	2	-	-	1
OUTA p	0110 1111 000p pppp	PORT[p] ← Acc	2	2	-	-	1
OUTM p	0110 1111 100p pppp	PORT[p] ← RAM[HL]	2	2	-	-	1

Preliminary

**(11) Flag manipulation**

Mnemonic	Object code ( binary )	Operation description	Byte	Cycle	Flag		
					C	Z	S
TFCFC	0101 0011	SF←CF', CF←0	1	1	0	-	*
TTCFS	0101 0010	SF←CF, CF←1	1	1	1	-	*
TZS	0101 1011	SF←ZF	1	1	-	-	*

**(12) Interrupt control**

Mnemonic	Object code ( binary )	Operation description	Byte	Cycle	Flag		
					C	Z	S
CIL r	0110 0011 11rr rrrr	IL←IL & r	2	2	-	-	1
DICIL r	0110 0011 10rr rrrr	EIF←0, IL←IL&r	2	2	-	-	1
EICIL r	0110 0011 01rr rrrr	EIF←1, IL←IL&r	2	2	-	-	1
EXAE	0111 0101	MASK↔Acc	1	1	-	-	1
RTI	0100 1101	SP←SP+1, FLAG.PC ←STACK[SP], EIF ←1	1	2	*	*	*

**(13) CPU control**

Mnemonic	Object code ( binary )	Operation description	Byte	Cycle	Flag		
					C	Z	S
NOP	0101 0110	no operation	1	1	-	-	-

**(14) Timer/Counter & Data pointer & Stack pointer control**

Mnemonic	Object code ( binary )	Operation description	Byte	Cycle	Flag		
					C	Z	S
LDADPL	0110 1010 1111 1100	Acc←[DP] <sub>L</sub>	2	2	-	Z	1
LDADPM	0110 1010 1111 1101	Acc←[DP] <sub>M</sub>	2	2	-	Z	1
LDADPH	0110 1010 1111 1110	Acc←[DP] <sub>H</sub>	2	2	-	Z	1
LDASP	0110 1010 1111 1111	Acc←SP	2	2	-	Z	1
LDATAL	0110 1010 1111 0100	Acc←[TA] <sub>L</sub>	2	2	-	Z	1
LDATAM	0110 1010 1111 0101	Acc←[TA] <sub>M</sub>	2	2	-	Z	1
LDATAH	0110 1010 1111 0110	Acc←[TA] <sub>H</sub>	2	2	-	Z	1
LDATBL	0110 1010 1111 1000	Acc←[TB] <sub>L</sub>	2	2	-	Z	1
LDATBM	0110 1010 1111 1001	Acc←[TB] <sub>M</sub>	2	2	-	Z	1
LDATBH	0110 1010 1111 1010	Acc←[TB] <sub>H</sub>	2	2	-	Z	1
STADPL	0110 1001 1111 1100	[DP] <sub>L</sub> ←Acc	2	2	-	-	1
STADPM	0110 1001 1111 1101	[DP] <sub>M</sub> ←Acc	2	2	-	-	1
STADPH	0110 1001 1111 1110	[DP] <sub>H</sub> ←Acc	2	2	-	-	1
STASP	0110 1001 1111 1111	SP←Acc	2	2	-	-	1
STATAL	0110 1001 1111 0100	[TA] <sub>L</sub> ←Acc	2	2	-	-	1
STATAM	0110 1001 1111 0101	[TA] <sub>M</sub> ←Acc	2	2	-	-	1
STATAH	0110 1001 1111 0110	[TA] <sub>H</sub> ←Acc	2	2	-	-	1
STATBL	0110 1001 1111 1000	[TB] <sub>L</sub> ←Acc	2	2	-	-	1
STATBM	0110 1001 1111 1001	[TB] <sub>M</sub> ←Acc	2	2	-	-	1
STATBH	0110 1001 1111 1010	[TB] <sub>H</sub> ←Acc	2	2	-	-	1

\* This specification are subject to be changed without notice.

**Preliminary**

\*\*\*\* SYMBOL DESCRIPTION

Symbol	Description	Symbol	Description
HR	H register	LR	L register
PC	Program counter	DP	Data pointer
SP	Stack pointer	STACK[SP]	Stack specified by SP
A <sub>CC</sub>	Accumulator	FLAG	All flags
CF	Carry flag	ZF	Zero flag
SF	Status flag	EI	Enable interrupt register
IL	Interrupt latch	MASK	Interrupt mask
PORT[p]	Port ( address : p )	TA	Timer/counter A
TB	Timer/counter B	RAM[HL]	Data memory ( address : HL )
RAM[x]	Data memory ( address : x )	ROM[DP] <sub>L</sub>	Low 4-bit of program memory
ROM[DP] <sub>H</sub>	High 4-bit of program memory	[DP] <sub>L</sub>	Low 4-bit of data pointer register
[DP] <sub>M</sub>	Middle 4-bit of data pointer register	[DP] <sub>H</sub>	High 4-bit of data pointer register
[TA] <sub>L</sub> ([TB] <sub>L</sub> )	Low 4-bit of timer/counter A (timer/counter B) register	[TA] <sub>M</sub> ([TB] <sub>M</sub> )	Middle 4-bit of timer/counter A (timer/counter B) register
[TA] <sub>H</sub> ([TB] <sub>H</sub> )	High 4-bit of timer/counter A (timer/counter B) register	LR <sub>1-0</sub>	Contents of bit assigned by bit 1 to 0 of LR
LR <sub>3-2</sub>	Bit 3 to 2 of LR	a <sub>5-0</sub>	Bit 5 to 0 of destination address for branch instruction
PC <sub>12-6</sub>	Bit 12 to 6 of program counter	←	Transfer
↔	Exchange	+	Addition
-	Substraction	&	Logic AND
	Logic OR	^	Logic XOR
'	Inverse operation	.	Concatenation
#k	4-bit immediate data	x	8-bit RAM address
y	4-bit zero-page address	p	4-bit or 5-bit port address
b	Bit address	r	6-bit interrupt latch