

Features

- High brightness AllnGaP die material
- Dome lens provides intensified narrow, bright beam
- Available for both standard and reverse mounting
- Wider operating temperature: -40° ~ +100°C

Applications

- High-beam indicator for automotive use
- Backlighting for automotive dashboards
- Indoor / outdoor full-color signboards

Outline Dimensions

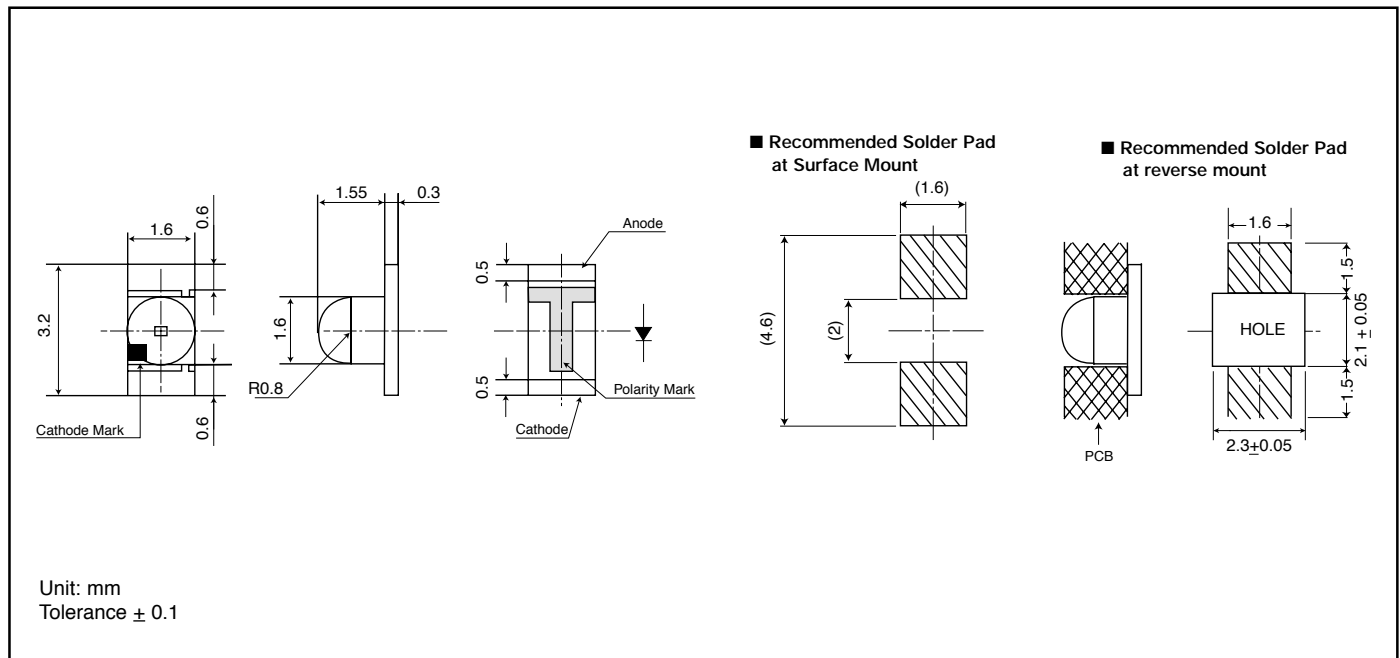

Electro-Optical Characteristics

(Ta=25°C)

Part No.	Material	Emitted Color	Lens Color	Luminous Intensity I _v			Wavelength				Forward Voltage v _f			Reverse Current I _r		Viewing Angle (2 θ 1/2)
				MIN.	TYP.	I _f	Peak λ _p TYP.	Dominant λ _d TYP.	Spectral Line Half Width Δλ TYP.	I _f	TYP.	MAX.	I _f	MAX.	V _r	
FR1105W	AllnGaP	Red	Water Clear	70	180	20	635	626	15	20	1.9	2.4	20	100	5	50°
FA1105W	AllnGaP	Orange		70	200	20	609	605	15	20	1.9	2.4	20	100	5	
FY1105W	AllnGaP	Yellow		70	180	20	592	590	15	20	1.9	2.4	20	100	5	
Units				mcd	mA		nm			mA		V		μA	V	Deg.

Absolute Maximum Ratings

Item	Symbol	Red-Orange	Orange-Red	Amber	(Ta=25°C) Units
		FR	FA	FY	
Power Dissipation	Pd	81	81	81	mW
Forward Current	I _F	30	30	30	mA
Peak Forward Current	I _{FM}	100	100	100	mA
Reverse Voltage	V _R	5	5	5	V
Operating Temperature	Topr	-40 to +100			°C
Storage Temperature	Tstg	-40 to +120			°C
Derating*	ΔI _F	1.0 (DC) 3.33 (Pulse)			mA/°C

* Ta=25°C, I_{FM} applies for the pulse width ≤ 1msec. and duty cycle ≤ 1/20.

Taping Specifications for Reverse Mount Type

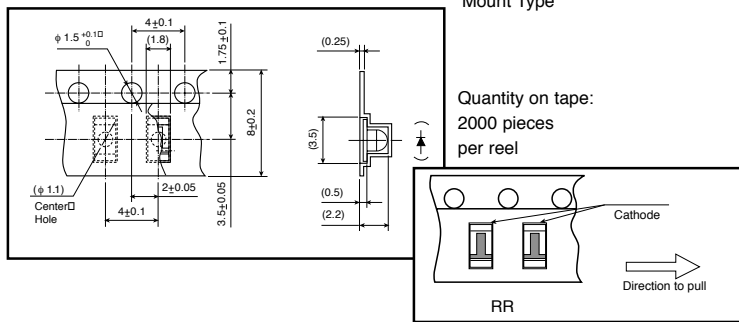

Taping Specifications for Standard Mount Type

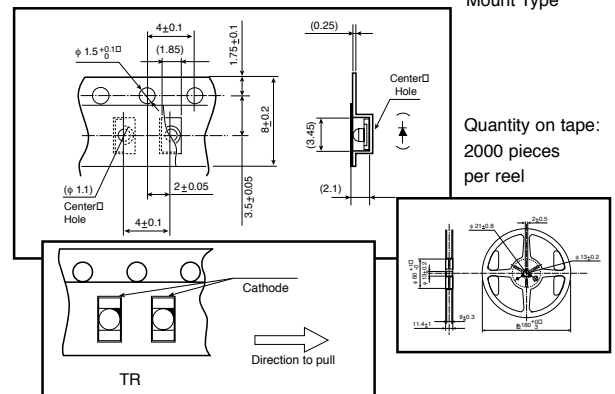

Operation Current Derating Chart (DC)

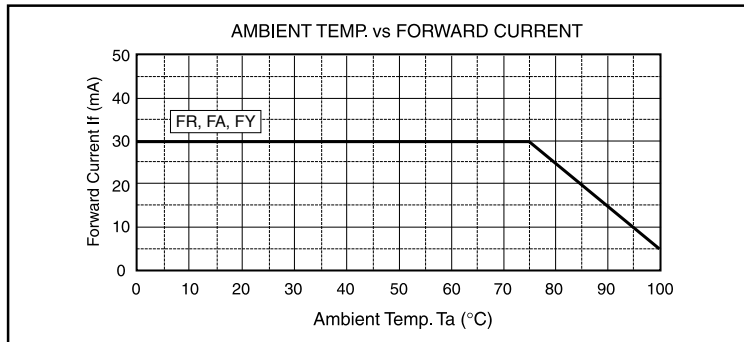

Spatial Distribution

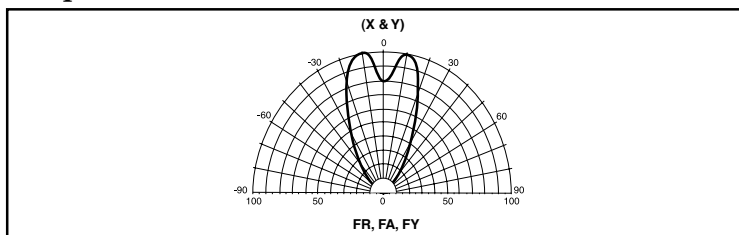

Precautions

Please follow these handling precautions to prevent damage to the chip and ensure its reliability.

1. Soldering conditions:

- **Soldering iron:** Temperature at tip of iron: 280°C max. (30W max.) Soldering time: 3 sec. max.
- **Dip soldering:** Preheating: 120 ~ 150°C max. (resin surface temp.) 60 ~ 120 sec. max. Bath temperature: 260°C max. Dipping Time: 5 sec. max.
- **Reflow Soldering:**

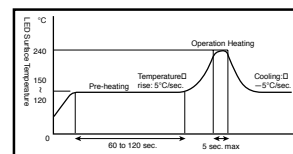

2. Cleaning:

- If cleaning is required, use the following solutions for less than 1 minute, at less than 40°C.
- Appropriate chemicals: Ethyl alcohol and isopropyl alcohol.
- Effect of ultrasonic cleaning on the LED resin body differs depending on such factors as the oscillator output, size of PCB and LED mounting method. The use of ultrasonic cleaning should be enforced at proper output after confirming there is no problem.

Product specifications subject to change without notice. PGF_1105W-0301

