

IL91210E

Tone/Pulse Dialer
High-Performance Silicon-Gate CMOS

The IL91210E is a single-chip, silicon gate, CMOS integrated circuit with an on-chip oscillator for a 3.58 MHz crystal or ceramic resonator. It provides dialing pulse (DP) or dual tone multi-frequency (DTMF) dialing. A standard 4x4 matrix keyboard can be used to support either DP or DTMF modes. Up to 32 digits can be saved in the on-chip RAM for reading. In the DTMF mode, minimum tone duration and minimum intertone pause are provided for rapid dialing. Maximum tone duration is dependent upon the key depression time in manual dialing.

- One touch redial operation
- Tone/Pulse switchable
- 32-digit capacity for redialing
- Automatic mixed redialing (last number redial) of pulse to DTMF with multiple automatic access pauses
- PABX auto-pause is 2.2 second
- DTMF Timing:

Manual dialing: minimum duration for bursts and pauses

Redialing: calibrated timing

- Wide operating voltage range: 2 V to 5.5 V
- Digits dialed manually after redialing are cascable and stored as additional digits for the next redialing
- Uses inexpensive ceramic resonator (3.58 MHz)
- Built-in power up reset circuit
- Four extra function keys: flash, pause, redial and DP or DTMF mixed dialing
- Four-by-four (or 2 of 8) keyboard can be used
- Low standby current
- Dial Pulse Rate: 10 pps

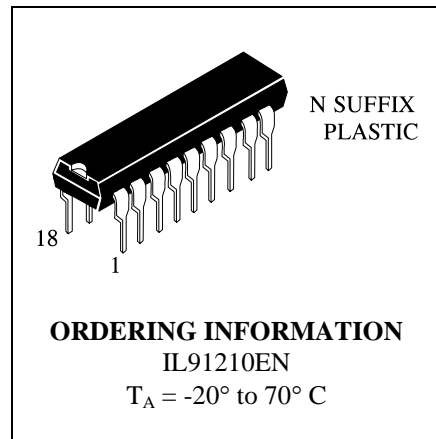

PIN ASSIGNMENT

$\overline{R1}$	1 ●	18	$\overline{C4}$
$\overline{R2}$	2	17	$\overline{C3}$
$\overline{R3}$	3	16	$\overline{C2}$
$\overline{R4}$	4	15	$\overline{C1}$
\overline{HK}	5	14	\overline{DP}
M/B	6	13	$\overline{XMITMUTE}$
MODE SELECT	7	12	TONE
OSCI	8	11	GND
OSCO	9	10	V _{CC}

LOGIC DIAGRAM

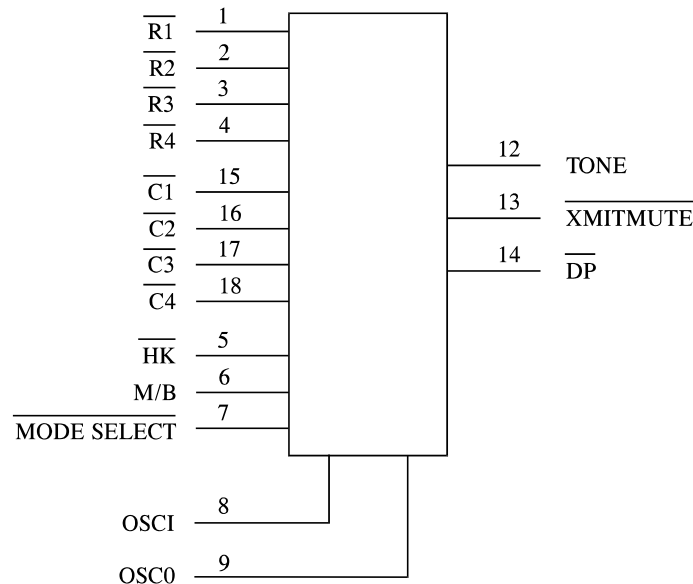

PIN 11 = GND
PIN 10 = V_{CC}

Keyboard Assignments*

1	2	3	F1	—	R1
4	5	6	F2	—	R2
7	8	9	P	—	R3
*/T	0	#	RD	—	R4

C1
C2
C3
Internal Pull Low

*Notes:

1. */T - At Pulse mode this key works as Pulse -> DTMF key (T key), at DTMF mode the key works as *key. */T key will occupy one memory digit in either mode.
2. F1 - Flash key. The break time is 96 ms.
3. F2 - Flash key for break time 640 ms.
4. P -- Pause key (2.2 seconds).
5. RD - One key redial key.
6. # - At pulse mode this key input is neglected, at DTMF mode this key works as # key.

Pin Description

Pin No.	Designation	Description
1	$\overline{R1}$	Key board pins. These inputs serve as the interface to a 4x4 matrix keyboard.
2	$\overline{R2}$	
3	$\overline{R3}$	
4	$\overline{R4}$	
5	\overline{HK}	Hook switch input. This inverter input pin detects the state of the hook switch contact. "Off Hook" is represented by a GND condition. "On Hook" is represented by a V_{CC} condition.
6	M/B	Make/Break Ratio Select Input. This input allows selection of the Make/Break ratio. M/B = V_{CC} : 1/2 M/B = GND : 2/3
7	$\overline{\text{MODE SELECT}}$	Mode select input. This input allows the selection of pulse mode or DTMF mode. $\overline{\text{MODE SELECT}} = V_{CC}$: Pulse mode operation $\overline{\text{MODE SELECT}} = \text{GND}$: Tone mode operation
8 9	OSCI OSC0	Oscillator Input and Output pins. The time base for IL91210E is a crystal controlled on-chip oscillator, which is completed by connecting a 3.58 MHz crystal or ceramic resonator between OSCI and OSC0 pins.
10	V_{CC}	Power supply pins. This device is designed to operate from 2.0 V to 5.5 V.
11	GND	
12	$\overline{\text{TONE}}$	Tone dialing output. When a valid keypress is detected in the DTMF mode, appropriate low group and high group frequencies are generated, which hybridize the dual tone output. TONE output is in the "OFF" state in pulse mode.
13	$\overline{\text{XMITMUTE}}$	Dialing transmission mute output. This is an N-channel open drain output The XMIMUTE is normally "OFF". During pulse or DTMF dialing this output is "ON".
14	DP	Dialing pulse output. This is an N-channel open drain output. The normal output will be "ON" during Break and "OFF" during Make in the pulse dialing mode.
15	$\overline{C1}$	Key board pins. These inputs serve as the interface to a 4x4 matrix keyboard.
16	$\overline{C2}$	
17	C3	
18	C4	
		Internal Pull low.

Operation Procedures

Symbol Definitions:

In the description below, signals are defined in terms of the key or switch which is activated.

Off Hook means the phone was taken off the hook.

On Hook means that the receiver is on the hook.

D1 stands for the first digit dialed in a string of digits.

Dn stands for the last digit dialed in a string of digits.

Dn+1 stands for the beginning of a new string of digits.

Dn+m stands for the last digit in a new string of digits.

***/T** is the Pulse-to-DTMF key

RD is the Redial key

O is the Zero key.

P is the Pause key.

F is the Flash key.

1. Pulse mode operation

a. **Off Hook** **D1** **Dn**

Pulse mode is defined as the initial mode, provided the first keyboard input is not the */T key following the Off Hook condition and the mode selection pin is V_{CC} (MODE SELECT = V_{CC}).

b. Pulse mode is defined as the initial mode, provided the key input D1 is not */T while the mode selection pin is V_{CC}. The chip will pause for 824 ms automatically after it detects an Off Hook condition. It then proceeds with pulse or DTMF dialing if any keys have been depressed. The dialing rate or make/break ratio is decided at the first key entry by checking the MODE SELECT & M/B status and will not be altered. The MODE SELECT status can only switch the dialing mode from Pulse to DTMF after the first key entry.

2. DTMF mode operation

a. **Off Hook** **D1** **Dn**

DTMF mode is defined as the initial mode of the mode selection pin if MODE SELECT is GND.

b. **Off Hook** ***/T** **D1** **Dn**

The initial mode is pulse mode if the mode selection pin, MODE SELECT, is V_{CC}. The */T key can switch the dialing mode to tone mode.

Unlike normal mode switching, the */T key entry, as the first key pressed, will not produce any pause time. There are only 31 digit of redial memory available in the buffer to be used for operations a and b, since the mode switching key, */T, will occupy one digit of space.

3. Manual dialing with automatic access pause

Off Hook **O** ***/T** **D1** **Dn**

Pause key entries can be accepted and stored in the redial memory. Each is stored as a digit. Each key-in will provide a pause of 2.2 seconds, depending on which model you are using.

4. Redial

a. **Off Hook** **RD**

Up to 32 digits (in pulse mode) or 31 digits (in tone mode) can be dialed using the RD is disabled while pulse or tone signals are being transmitted. Redial will also be inhibited if the last number dialed exceeds 32 digits because the redial memory can only hold 32 digits.

b. **Off Hook** **RD** **D1** **Dn**

After pressing the RD key, we can add digits to the number in redial memory. When finished dialing, the redial memory will contain the original digits plus the digits dialed after pressing RD. Each time the redial key is pressed, the stored number will be dialed exactly the same as it was previously, regardless of the status of the MODE SELECT pin.

5. TONE/PULSE switching operation

a. **Off Hook** **D1** ... **Dn**
 MODE SELECT pin Pulse Mode switched to GND
Dn+1 ... **Dn+m** DTMF Mode

The mode selection pin is always checked for tone or pulse mode key entry. Dialing can be switched from pulse to tone mode, but not from tone to pulse mode. Switching the MODE SELECT pin to GND will cause the chip to store a */T digit prior to the first tone digit in the redial memory and will automatically insert a 2.2 second pause before the tone digits are dialed out. After the mode has been switched, the status of the mode selection pin will no longer be checked. Therefore, it will not be possible to switch from tone to pulse mode.

b. Off Hook D1 ... Dn */T Dn+1 Pulse Mode Dn+m DTMF Mode

Pulse mode is initially defined with the mode selection pin, **MODE SELECT**, equal to V_{CC} . At this time, the mode can be switched to DTMF by pressing the */T key. DTMF mode will begin as soon as the last pulse has been transmitted. In this mode, Dn+1 through Dn+m are sent through the TONE OUT pin as DTMF signals. If a P key entry is contained in the series of digits before or after the */T entry, or the **MODE SELECT** switch is depressed, 2.2 second pause will be added to the automatically inserted pause time, which is also 2.2 seconds. Both of the above switching modes can store as many as 31 digits in the redial memory.

6. One-Key redialing

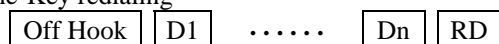

If the dialing of D1 to Dn is completed, pressing RD will cause the pulse dialing pin to go low for 2.2 seconds of break time and an 824 ms pause will automatically be added. Otherwise, the pressing of the redial key will be ignored.

7. Flash dialing

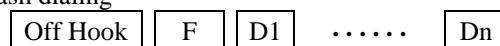

The flash keys emulate quick On-Off Hook operations. Pressing the flash keys, F1 or F2, will cause a break of 96 ms or 640 ms on the DP output pin. Then, it will pause for 824 ms and continue dialing the digits, D1 to Dn. These digits are then stored in the redial memory. Each time the flash key is pressed, the redial memory will be cleared to store a new entry. In addition, the **MODE SELECT** status will be checked again for the setting of the Tone/Pulse dialing mode.

Similarly, to make sure that the IC is working properly, new flash key inputs will be ignored as long as the digits that were dialed have not finished.

MAXIMUM RATINGS*

Symbol	Parameter	Value	Unit
V_{CC}	DC Supply Voltage (Referenced to GND)	-0.3 to +6.0	V
V_{IN}	DC Input Voltage (Referenced to GND)	-0.3 to $V_{CC} + 0.3$	V
V_{OUT}	DC Output Voltage (Referenced to GND)	-0.3 to $V_{CC} + 0.3$	V
V_{OUT}	DC Output Voltage (\overline{DP} , $\overline{XMITMUTE}$)	-0.3 to 1.2	V
I_{TONE}	DC Output Current(Tone)	50	mA
P_D	Power Dissipation in Still Air, Plastic DIP**	500	mW
Tstg	Storage Temperature	-40 to +125	°C

* Maximum Ratings are those values beyond which damage to the device may occur. Functional operation should be restricted to the Recommended Operating Conditions.

** Durating: $-10 \text{ mW}/^\circ\text{C}$ from 65°C to 70°C .

RECOMMENDED OPERATING CONDITIONS

Symbol	Parameter	Min	Max	Unit
V _{CC}	DC Supply Voltage (Referenced to GND)	2.0	5.5	V
V _{IN}	DC Input Voltage (Referenced to GND)	0	V _{CC}	V
V _{OUT}	DC Output Voltage (Referenced to GND)	0	V _{CC}	V
T _A	Operating Temperature	-20	+70	°C

This device contains protection circuitry to guard against damage due to high static voltages or electric fields. However, precautions must be taken to avoid applications of any voltage higher than maximum rated voltages to this high-impedance circuit. For proper operation, V_{IN} and V_{OUT} should be constrained to the range GND ≤ (V_{IN} or V_{OUT}) ≤ V_{CC}.

Unused inputs must always be tied to an appropriate logic voltage level (e.g., either GND or V_{CC}). Unused outputs must be left open.

DC ELECTRICAL CHARACTERISTICS (Voltages Referenced to GND, V_{CC} = 2.0 V to 5.5 V, T_A = -20 to +70°C)

Symbol	Parameter	Test Conditions		Guaranteed Limits		Unit
				Min	Max	
V _{IH}	High-Level Input Voltage			0.8V _{CC}	V _{CC}	V
V _{IL}	Low-Level Input Voltage			0	0.2V _{CC}	V
V _{MR}	Minimum Memory Retention Voltage	V _{CC} = 1.0 V		1.5		V
V _{OC}	Tone Output Voltage	Column	V _{CC} = 3.5 V R _L = 5KΩ	400	1000	mVp-p
V _{OR}	Tone Output Voltage	Row		300	800	mVp-p
I _R	Input Current (R1 - R4, C1 - C3)	V _{CC} = 3.5 V V _{IL} = 0 V		10	300	μA
I _{OL1}	Minimum Output Current, XMITMUTE	V _{CC} = 3.5 V V _{OL} = 0.4 V		0.5		mA
I _{OL2}	Minimum Output Sink Current, DP	V _{CC} = 3.5 V V _{OL} = 0.4 V		0.6		mA
I _{MR}	Memory Retention Current	V _{CC} = 1.0 V, $\overline{HK} = V_{CC}$ All outputs unloaded			0.6	μA
I _{CCP}	Maximum Operation Current	Pulse mode	All outputs unloaded		1.5	mA
I _{CCT}		Tone mode			3.0	mA
I _{SBP}	Maximum Standby Current	Pulse mode HK = V _{CC} = 1.5 V	All outputs unloaded. No key selected		0.05	μA
I _{SBT}		Tone mode HK = GND			15	
DIS%	Distortion	*Note 1, V _{CC} = 3.5 V			7	%

Note 1:

$$DIS\% = \frac{100 \cdot (V_1^2 + V_2^2 + \dots + V_n^2)^{1/2}}{(V_{OC}^2 + V_{OR}^2)^{1/2}}$$

- a. V₁ . . . V_n are the intermodulation or the harmonic frequencies in the 500 Hz to 3400 Hz band.
- b. V_{OC} and V_{OR} are the individual frequency components of the DTMF signal.

AC ELECTRICAL CHARACTERISTICS (All Voltages referenced to GND. $V_{CC}= 2.0\text{ V to }5.5\text{ V}$, $T_A = -20\text{ to }+70^{\circ}\text{C}$)

Symbol	Parameter	Test Conditions	Guaranteed Limits		Unit
			Min	Max	
T_M	Make Time (Figure 1)	M/B = 1/2	30	35	
		M/B = 2/3	38	42	
T_B	Break Time (Figure 1)	M/B = 1/2	64	69	ms
		M/B = 2/3	57	63	ms
T_{IDP}	Inter Digit Pause Time (Figures 1,2,3)		800	850	ms
T_{PAU}	Pause Time (Figures 3,5)		2.1	2.3	sec
T_{ROBK}	Auto-redial Break Time (Figure 4)		2.1	2.3	sec
T_D	Delay time Key valid to Signal Output (Figures 1,2,3)		0	3.0	ms
T_{KD}	Key-in Debounce (Figure 1)		20	25	ms
T_{KRD}	Key-release Debounce		3.0	5.0	ms
T_{KTD}	Key-in Tone Duration		21	25	ms
T_{MFD}	Minimum Tone Duration Time (Figures 2,3)		92	96	ms
T_{TIDP}	Minimum Tone Inter-digit Pause (Figure 2)		94	98	ms
T_{MFDR}	Redial Tone Duration (Figure 2)		92	96	ms
T_{TIDPR}	Redial Tone Inter-digit Duration (Figure 2)		94	98	ms

Comparisons of Specified vs. Actual Tone Frequencies

R/C	Spec.	Actual	Error(%)	Unit	Conditions
R1	697	699.1	+0.31	Hz	$F_{OSC} = 3.579\text{ MHz}$
R2	770	771.5	+0.19	Hz	
R3	852	852.3	+0.03	Hz	
R4	941	942.0	+0.10	Hz	
C1	1209	1,215.7	+0.57	Hz	
C2	1336	1,331.7	-0.32	Hz	
C3	1477	1,471.9	-0.35	Hz	

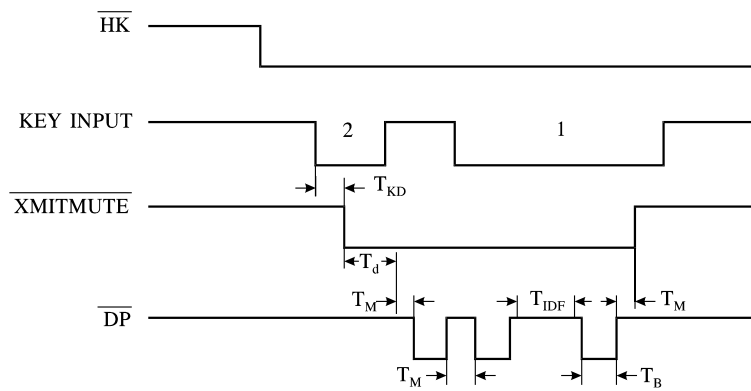
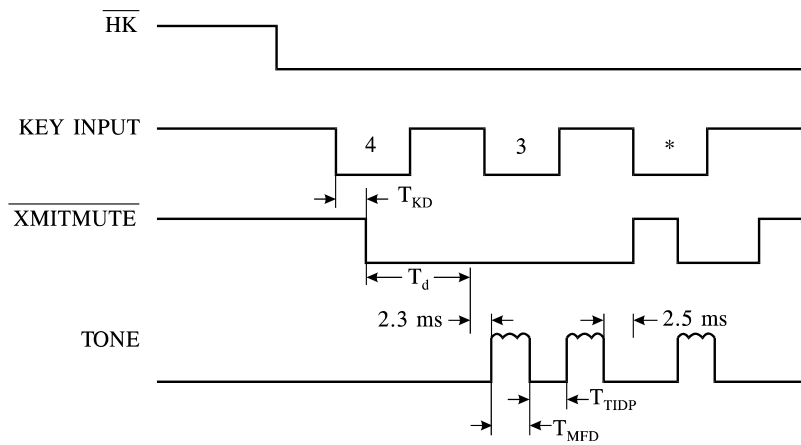

Figure 1. Pulse Mode

(i) Normal dialing



(ii) After (i), redialing

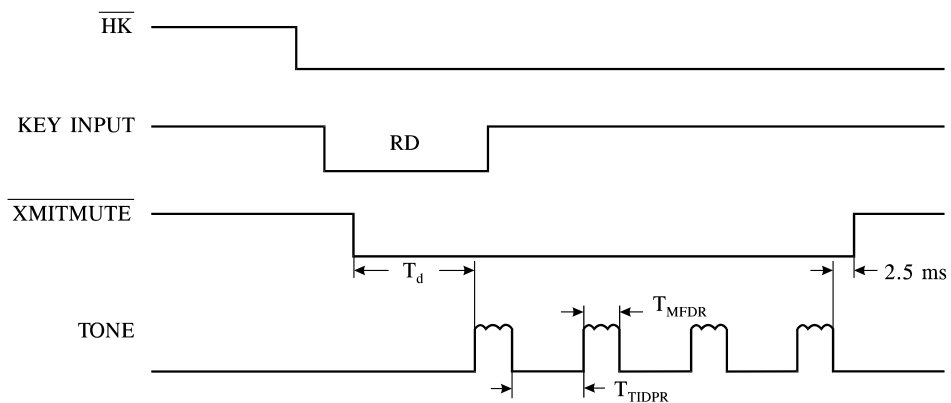
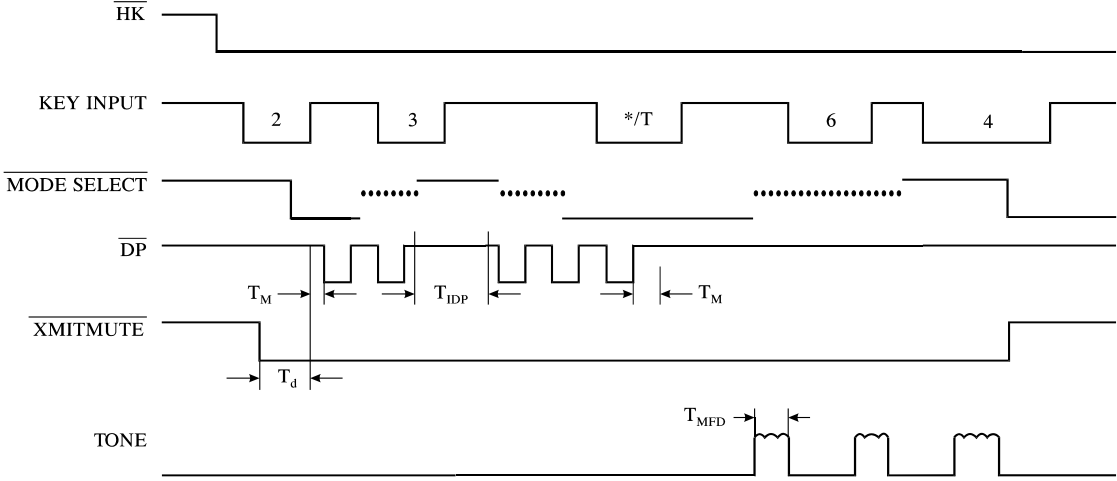

Figure 2. Tone Mode

(i) By mode selection pin switches



(ii) By */T key entry

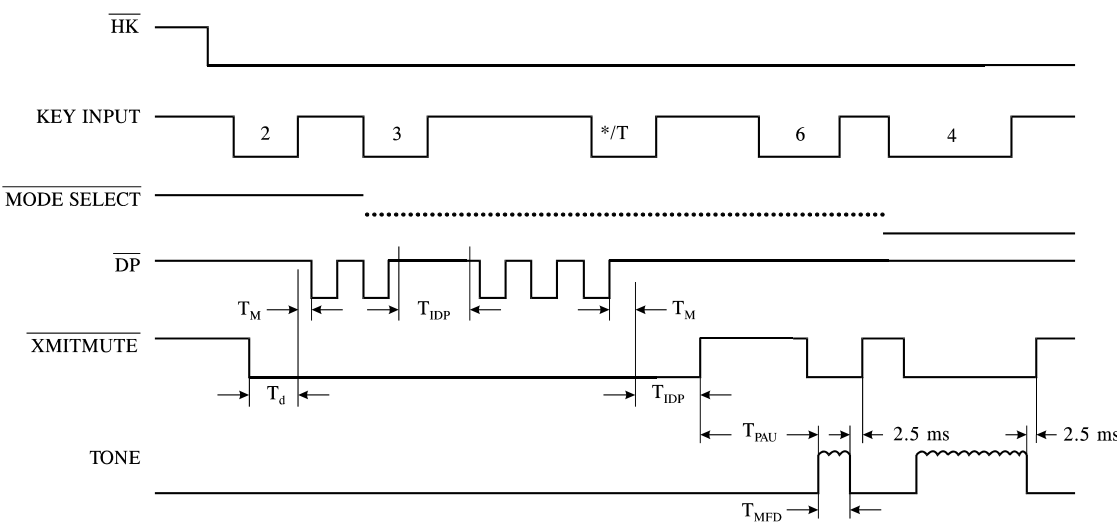

Figure 3. Switching Mode Operation

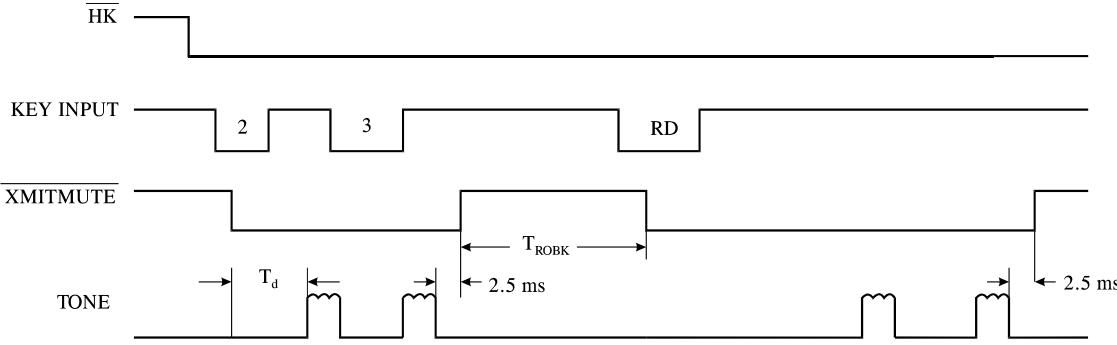
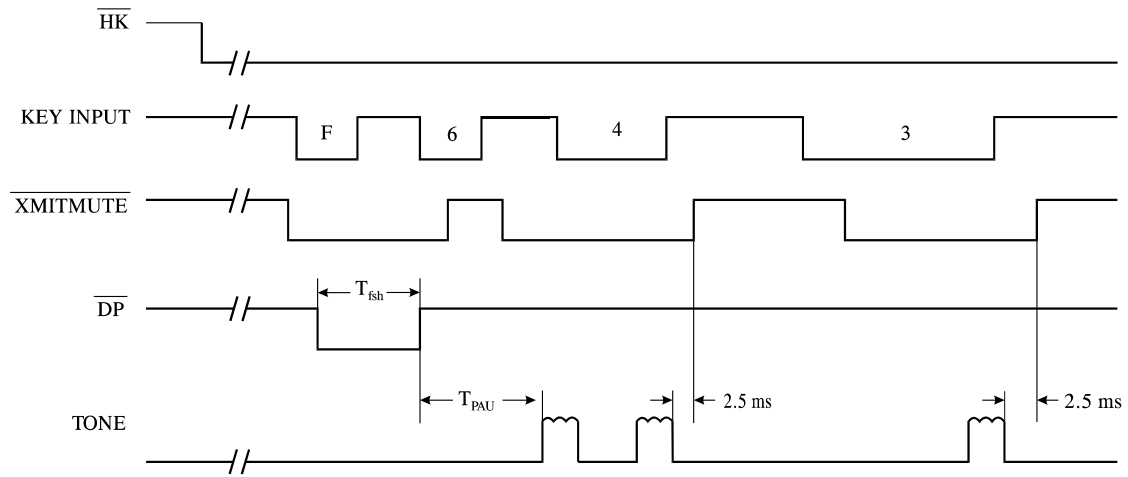

Figure 4. One Key Redial (DTMF mode for example)



Tfsh : Flash time (F1 : 96 ms, F2 : 640 ms)

Figure 5. Flash Dialing (DTMF mode for example)

EXPANDED LOGIC DIAGRAM

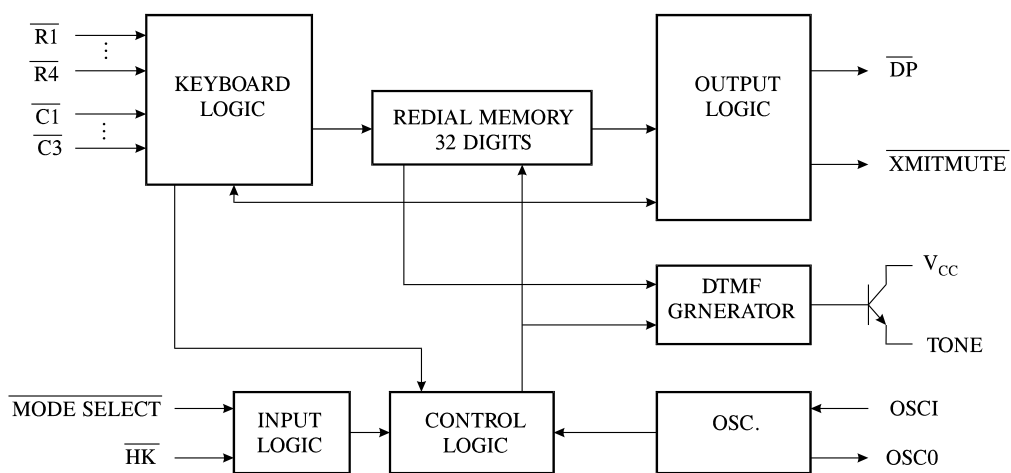

**N SUFFIX PLASTIC DIP
(MS - 001AC)**

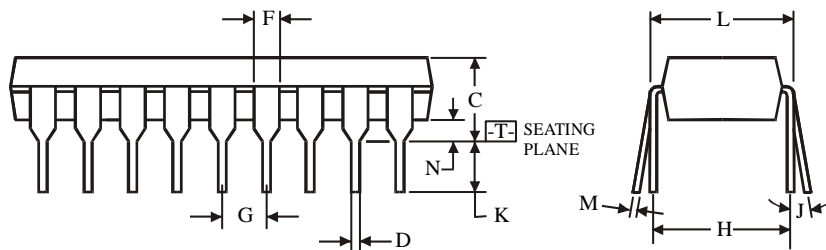
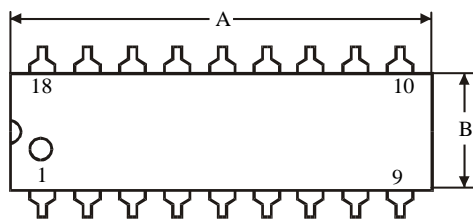
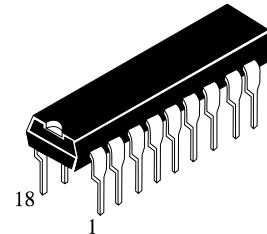

$\oplus 0.25 (0.010) \text{ (M) } T$

NOTES:

- Dimensions "A", "B" do not include mold flash or protrusions.
Maximum mold flash or protrusions 0.25 mm (0.010) per side.

Symbol	Dimension, mm	
	MIN	MAX
A	22.35	23.37
B	6.1	7.11
C		5.33
D	0.36	0.56
F	1.14	1.78
G	2.54	
H	7.62	
J	0°	10°
K	2.92	3.81
L	7.62	8.26
M	0.2	0.36
N	0.38	