

FEATURES

- 140 μ A typical current drain
- low noise and distortion
- 1.0 to 5 VDC operating range
- independent preamplifier
- 2 DC coupled stages
- class A output stage
- variable transducer current
- Schottky diodes for MPO control
- 4 k Ω microphone decoupling resistor

STANDARD PACKAGING

- 10 pin PLID[®]
- 10 pin SLT
- Chip (61 x 55 mils)

DESCRIPTION

The LS509 is a Class A amplifier utilizing Gennum's proprietary low voltage JFET technology. It consists of two single-ended, low noise inverting gain blocks, a Class A output stage, an on-chip microphone decoupling resistor and a pair of Schottky diodes for symmetrical peak clipping.

Blocks A and B typically have an open loop voltage gain of 56 dB, with the closed loop gain set by the ratio of the feedback resistor to the source impedance. It is recommended that the maximum closed loop gain be 20 dB lower than the open loop gain. All blocks of the device are internally bias compensated, preventing any DC current flow via external feedback resistors. Without this compensation, audible scratchiness would be present during changes in volume control settings.

The output stage of the LS509 is a Class A current drive. It has a fixed reference voltage of typically 29 mV at pin 2 of the device. The current that flows in the transducer is the ratio of the 29 mV reference voltage and the on-chip emitter resistor (R_E). To increase the bias current in the transducer, simply place an external R_E resistor from pin 2 to ground, thereby decreasing the equivalent emitter resistance and increasing the current.

The LS509 also contains a pair of Schottky diodes in the feedback configuration of the output stage, which provides approximately 12 dB of MPO control.

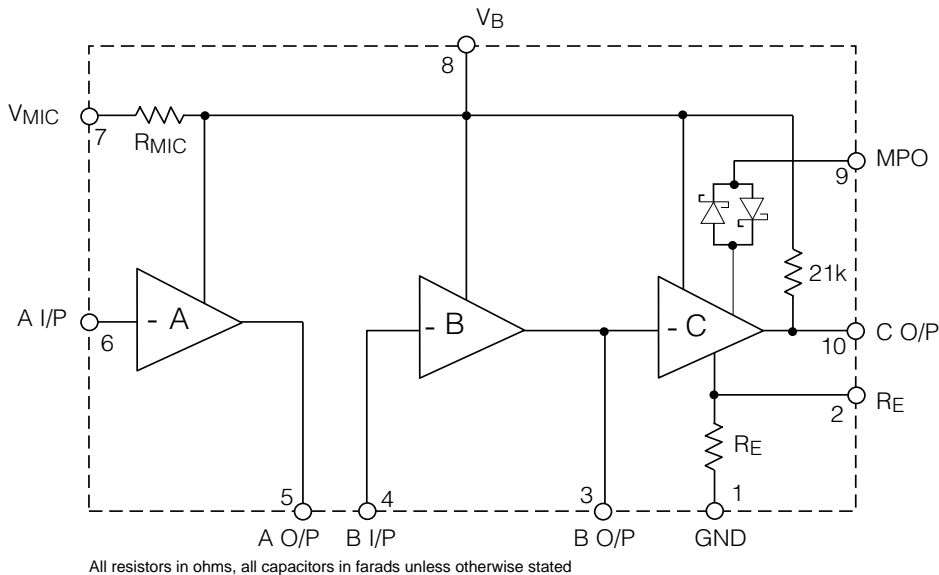

BLOCK DIAGRAM

ABSOLUTE MAXIMUM RATINGS

PARAMETER	VALUE/UNITS
Supply Voltage	5 V DC
Power Dissipation	25 mW
Operating Temperature Range	-10°C to 40° C
Storage Temperature Range	-20°C to 70° C

CAUTION
CLASS 1 ESD SENSITIVITY



PIN CONNECTION

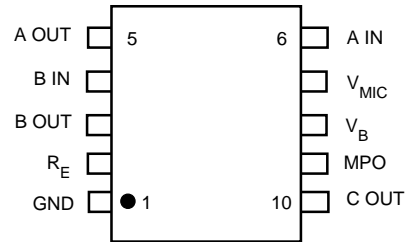

ELECTRICAL CHARACTERISTICS

V_p - Pin voltage measured with conditions as shown in Test Circuit.

Positive current corresponds to current INTO the pin.

Negative current corresponds with current OUT of the pin.

Conditions: Frequency = 1 kHz, Temperature = 25°C, Supply Voltage $V_B = 1.3$ V

PARAMETER	SYMBOL	CONDITIONS	MIN	TYP	MAX	UNITS
Amplifier Current	I_{AMP}		75	140	205	μA
Transducer Current	I_{TRANS}		170	230	290	μA
Maximum Transducer Current	$I_{TRANS (MAX)}$	$V_{P2} = 0$ V	2	-	-	mA
A Input Bias Voltage (pin 6)	$V_{BIAS A}$		500	570	650	mV
A Input Bias Current (pin 6)	$I_{BIAS A}$	$R_{FA} = 1$ M (Note 1)	-50	0	50	nA
B Input Bias Current (pin 4)	$I_{BIAS B}$	$R_{FB} = 1$ M (Note 2)	-50	0	50	nA
A O/P Voltage Swing-Hi (pin 5)	$V_{OH A}$	$V_{IN} = 0.4$ V DC, $R_{FA} = \infty$, $I_{P5} = -10$ μA (Note 3)	200	580	-	mV
A Output Swing-Lo (pin 5)	$V_{OL A}$	$I_{IN} = +1$ μA , $R_{FA} = \infty$, $I_{P5} = +10$ μA (Note 4)	200	280	-	mV
A Open Loop Voltage Gain	A_{OL}		46	56	-	dB
C Output Sat. Voltage (pin 10)	$V_{SAT C}$	$R_L = 1$ k Ω , $V_{P2} = 0$ V	-	100	180	mV
A Output Current Capability (pin 5)	A_{OUT}		-	30	-	μA
Diode Voltage Drop	V_D	(S2 = b) $R_L = \infty$, (Note 5)	140	265	325	mV
Emitter Bias Voltage (pin 2)	V_{RE}		21.5	28.5	35.5	mV
On-chip Microphone Resistor	R_{MIC}		3	4	5	k Ω
On-chip Emitter Resistor	R_E		90	125	160	Ω
Input Referred Noise	IRN	NFB 0.2 to 10kHz at 12dB/Oct	-	1	-	μV_{RMS}
Harmonic Distortion	THD	$V_{OUT} = 500$ mVRMS	-	1	-	%

All parameters and switches remain as shown in Test Circuit unless otherwise stated in "Conditions" column

- Notes**
- $I_{BIAS A} = (V_{P6} - V_{P6[RFA = 1M]}) / 1M$
 - $I_{BIAS B} = (V_{P4} - V_{P4[RFB = 1M]}) / 1M$
 - $V_{OH A} = (V_{P5} - V_{P5} [VIN = 0.4 VDC, RFA = \infty, IP5 = -10\mu A])$
 - $V_{OL A} = (V_{P5} - V_{P5} [IIN = +1\mu A, RFA = \infty, IP5 = +10\mu A])$
 - $V_D = (V_{P10} [Id = +(1.5 \times ITRANS)] - V_{P10} [Id = +(0.5 \times ITRANS)])$

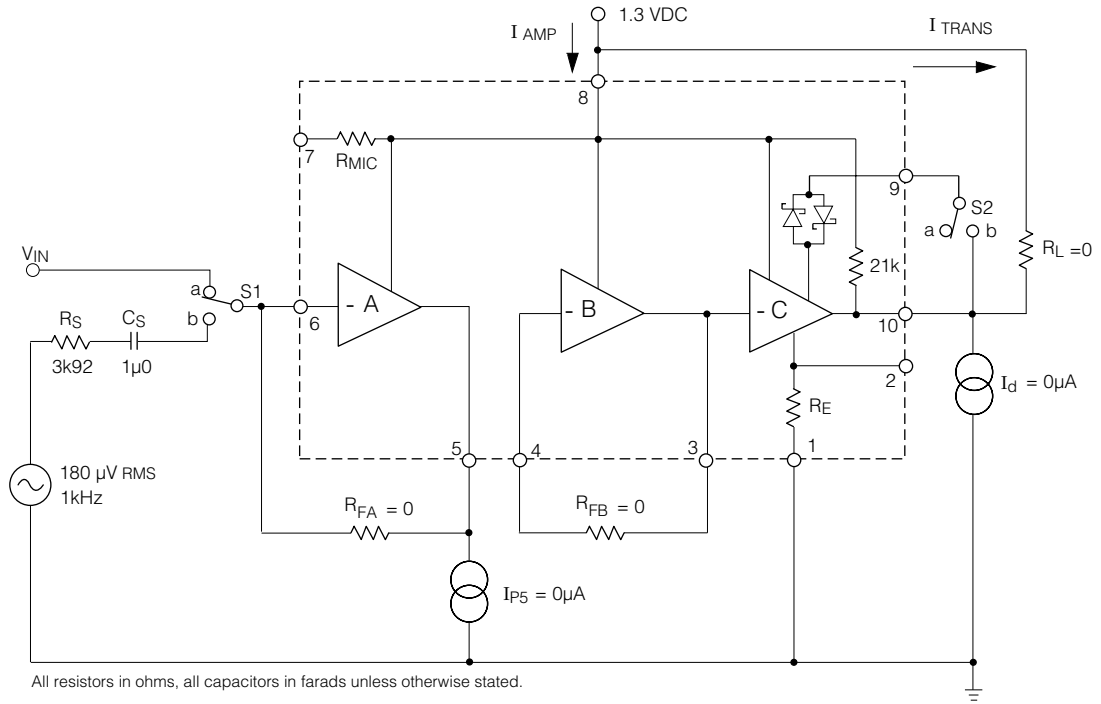

Fig. 1 Test Circuit

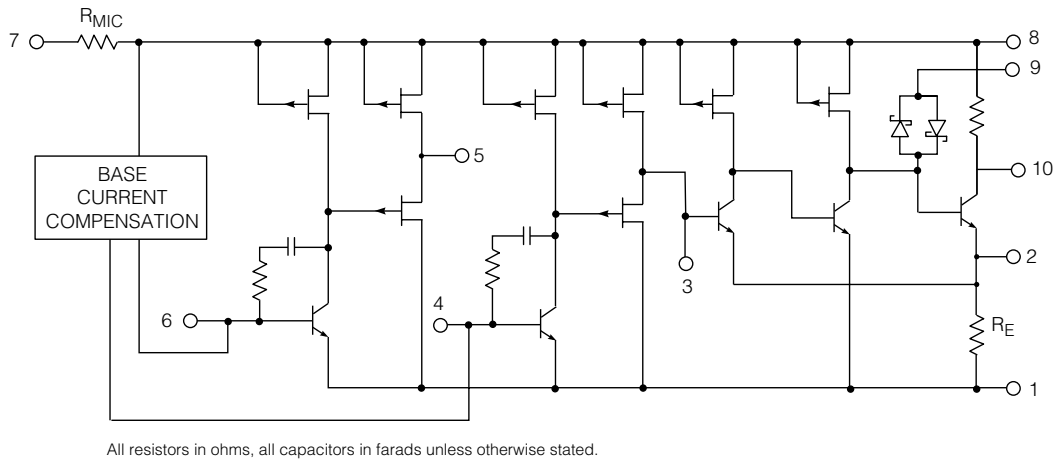

Fig. 2 Functional Schematic

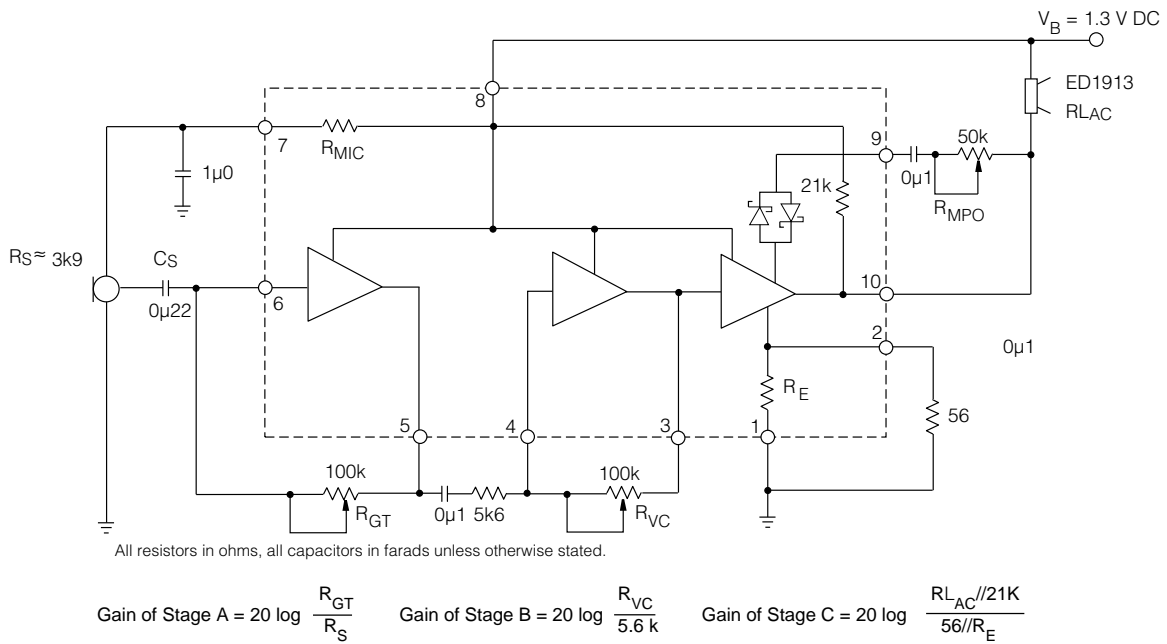

Fig 3 Typical Hearing Instrument Application

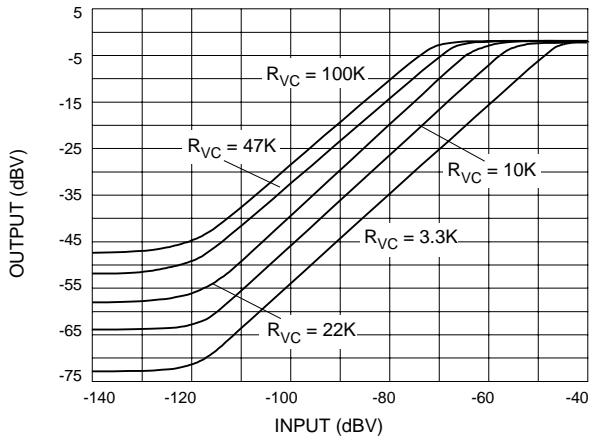

Fig. 4 I/O Curves at Various R_{VC} Settings

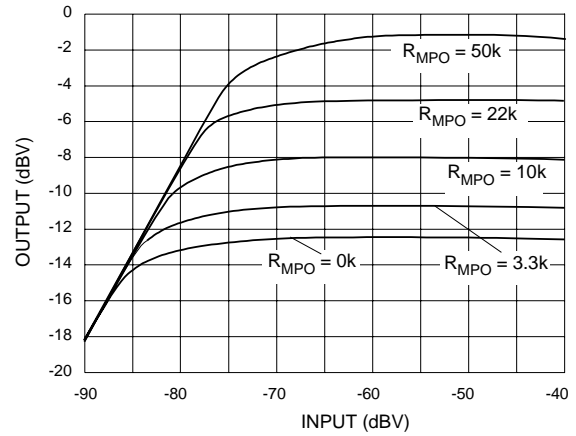

Fig. 5 I/O Curves at Various R_{MPO} Values

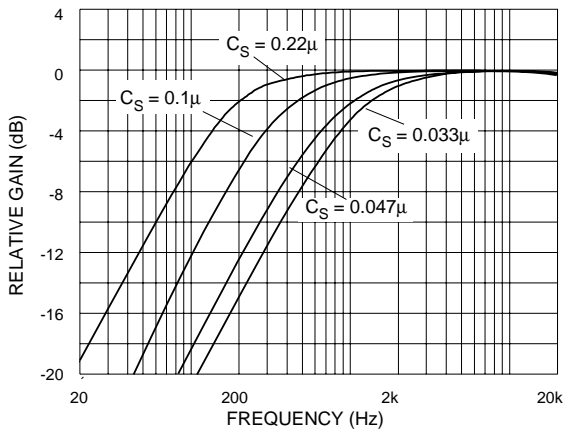

Fig. 6 Closed Loop Frequency Response with Various C_S Values

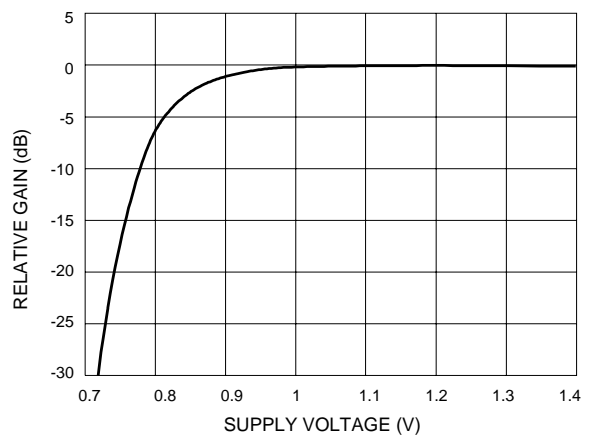

Fig. 7 Gain vs Supply Voltage

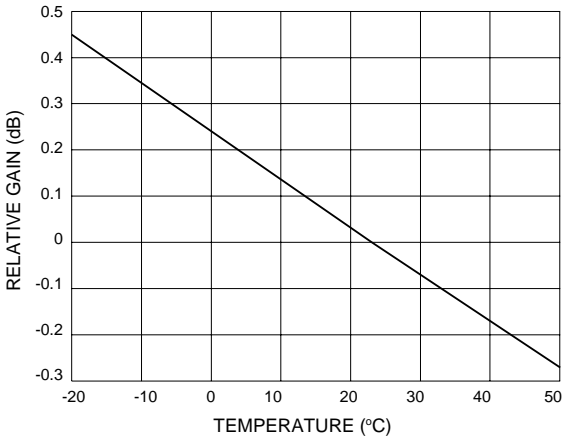

Fig. 8 Gain vs Temperature

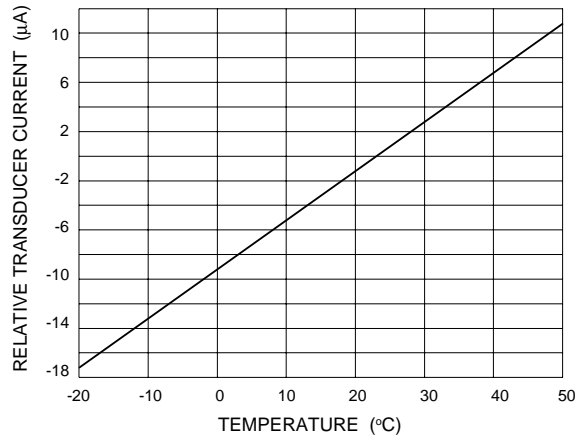

Fig. 9 Transducer Current vs Temperature

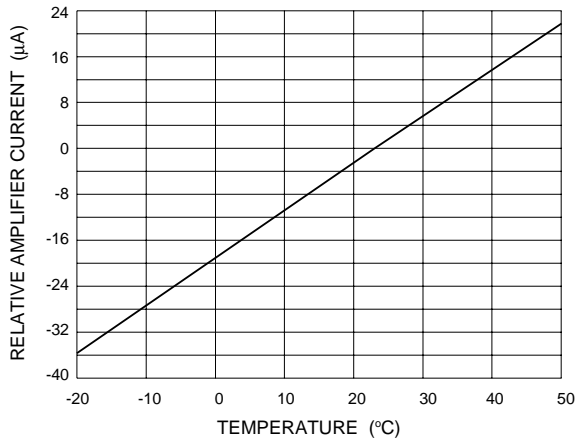

Fig. 10 Amplifier Current vs Temperature

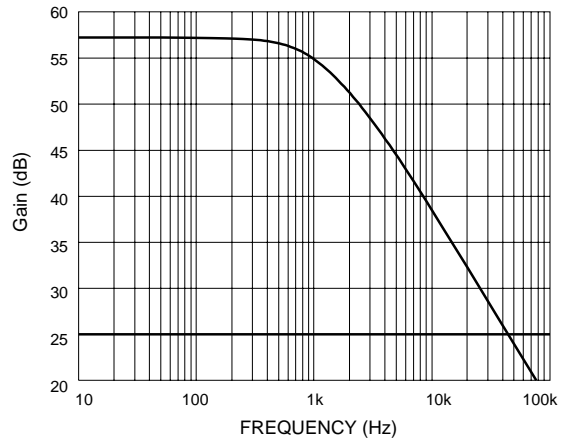

Fig. 11 Preamplifier A Open Loop Frequency Response

GENNUM CORPORATION
 MAILING ADDRESS:
 P.O. Box 489, Str. A, Burlington, Ontario, Canada L7R 3Y3
 Tel. +1 (905) 632-2996 Fax +1 (905) 632-2814
 SHIPPING ADDRESS:
 970 Fraser Drive, Burlington, Ontario, Canada L7L 5P5

GENNUM JAPAN CORPORATION
 C-101, Miyamae Village, 2-10-42 Miyamae, Suginami-ku, Tokyo 168-0081,
 Japan Tel. +81 (3) 3334-7700 Fax: +81 (3) 3247-8839

DOCUMENT IDENTIFICATION: DATA SHEET
 The product is in production. Gennum reserves the right to make changes at any time to improve reliability, function or design, in order to provide the best product possible.

REVISION NOTES:
 Changes to standard packaging information.