



The Future of Analog IC Technology™

EV1542DK-TFT-00A

MP1542 TFT Applications Evaluation Board

EVALUATION BOARD

GENERAL DESCRIPTION

The EV1542DK-TFT-00A is the evaluation board for TFT applications using the MP1542. The MP1542 can be operated at 700KHz or 1.3MHz allowing for easy filtering and low noise. An external compensation pin gives the user flexibility in setting loop dynamics, which allows the use of small, low-ESR ceramic output capacitors. Soft-start results in small inrush current and can be programmed with an external capacitor. The MP1542 operates from an input voltage as low as 2.5V and can generate 12V at up to 500mA from a 5V supply.

The EV1542DK-TFT-00A provides V_{OUT1} from the boost output and also derives V_{OUT3} (positive) and V_{OUT2} (negative) from the charge pumps off of the boost switching node.

ELECTRICAL SPECIFICATIONS

Parameter	Symbol	Value	Units
Input Voltage	V_{IN}	3 – 3.6	V
Output Voltage 1	V_{OUT1}	9	V
Output Current 1	I_{OUT1}	150	mA
Output Voltage 2	V_{OUT2}	-8	V
Output Current 2	I_{OUT2}	10	mA
Output Voltage 3	V_{OUT3}	26	V
Output Current 3	I_{OUT3}	5	mA

FEATURES

- 3 Outputs in a Single Package: Boost Converter for 9V, Positive Charge Pump for 26V and Negative Charge Pump for -8V
- 3V to 3.6V Operating Input Range
- Uses Tiny Capacitors and Inductors
- 700KHz/1.3MHz Fixed Switching Frequency
- Externally Compensated
- Programmable Soft-Start
- UVLO, Thermal Shutdown
- Internal Current Limit

APPLICATIONS

- Handheld Computers and PDAs
- Digital Still and Video Cameras
- Small LCD Displays

"MPS" and "The Future of Analog IC Technology" are Trademarks of Monolithic Power Systems, Inc.

EV1542DK-TFT-00A EVALUATION BOARD

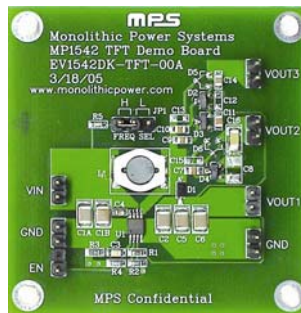

Dimensions (2.0"X x 2.0"Y x 0.4"Z)

Board Number	MPS IC Number
EV1542DK-TFT-00A	MP1542DK

EVALUATION BOARD SCHEMATIC

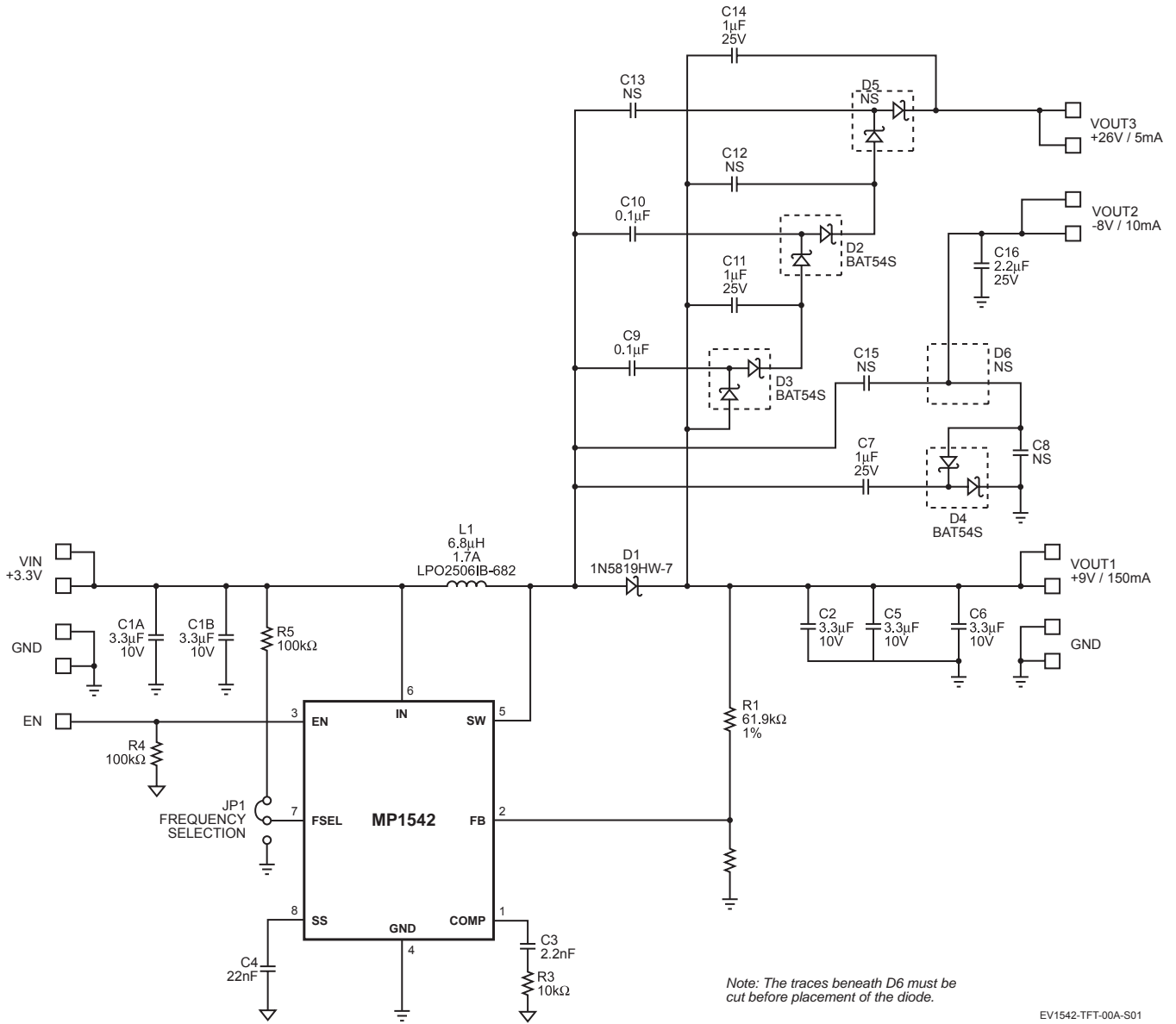

EV1542-TFT-00A-S01

EV1542DK-TFT-00A BILL OF MATERIALS

Qty	Ref	Value	Description	Package	Manufacturer	Manufacturer P/N
5	C1A, C1B, C2, C5, C6	3.3 μ F	Ceramic Cap, 10V, X7R	1210	Taiyo Yuden	LMK325BJ335KD
1	C3	2.2nF	Ceramic Cap, 100V, X7R	0805	TDK	C2012X7R2A222K
1	C4	22nF	Ceramic Cap, 50V, X7R	0603	TDK	C1608X7R1H223K
3	C7, C11, C14	1 μ F	Ceramic Cap, 25V, X7R	0805	TDK	C2012X7R1E105K
4	C8, C12, C13, C15		Do Not Stuff			
2	C9, C10	0.1 μ F	Ceramic Cap, 25V, X7R	0805	TDK	C2012X7R1E104K
1	C16	2.2 μ F	Ceramic Cap, 25V, X5R	1206	Murata	GRM316R61E225KA12D
1	D1		Schottky Diodes, 40V, 1A	SOD123	Diodes Inc	1N5819HW-7
3	D2, D3, D4		Schottky Diodes, 30V, 200mA	SOT-23	Fairchild	BAT54S
2	D5, D6		Do Not Stuff			
1	JP1		3-Pin Connector Header, 0.100		Sullins	PTC03SAAN
1	L1	6.8 μ H	1.7A		Coilcraft	LPO2506IB-682
1	R1	61.9k Ω	Resistor, 1%	0805	Panasonic	ERJ-6ENF6192V
1	R2	10k Ω	Resistor, 1%	0805	Panasonic	ERJ-6ENF1002V
1	R3	10k Ω	Resistor, 5%	0805	Panasonic	ERJ-6GEYJ103V
2	R4, R5	100k Ω	Resistor, 5%	0805	Panasonic	ERJ-6GEYJ104V
1	U1		DC-DC Converter	MSOP8	MPS	MP1542DK

PRINTED CIRCUIT BOARD LAYOUT

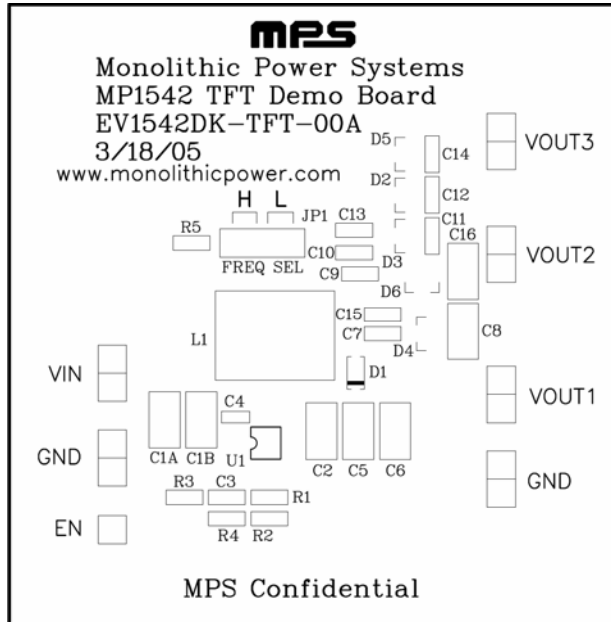

Figure 1—Top Silk Layer

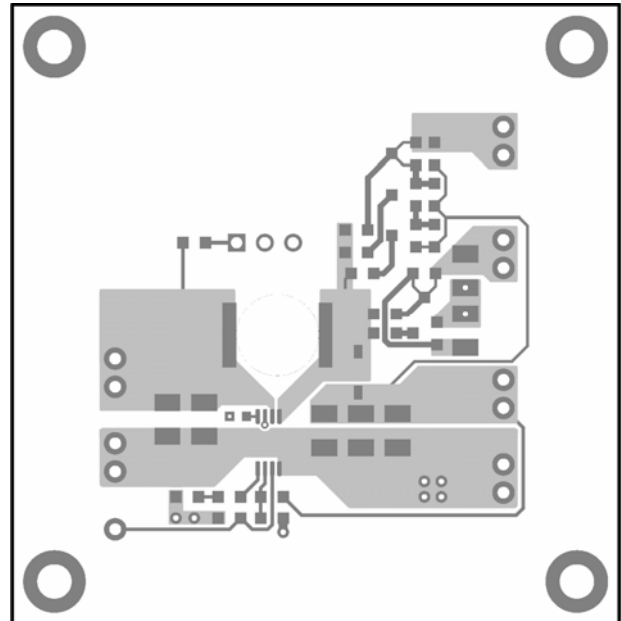

Figure 2—Top Layer

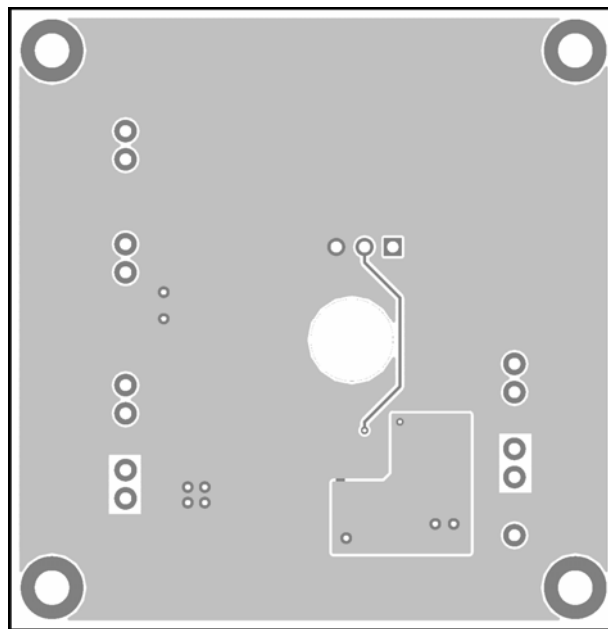

Figure 3—Bottom Layer

QUICK START GUIDE

The output voltage of this board is set to 9V, -8V and 26V on VOUT1, VOUT2 and VOUT3, respectively. The board layout accommodates most commonly used inductors and output capacitors.

1. Preset the power supply to $3V \leq V_{IN} \leq 3.6V$.
2. Turn off the power supply.
3. Connect the power supply terminals to:
 - a. Positive (+): VIN, EN
 - b. Negative (-): GND
4. Connect the load to:
 - a. Positive (+): VOUT1, VOUT3, GND (for the negative output)
 - b. Negative (-): GND, VOUT2 (for the negative output)
5. Turn on the power supply after making the connections.
6. The MP1542 is disabled on the evaluation board if only VIN is applied. To enable the MP1542, EN needs to be pulled HIGH.
7. The output voltage V_{OUT1} can be changed by varying R1. Calculate the new value using the formula:

$$R1 = \left(\frac{V_{OUT1}}{V_{FB}} - 1 \right) R2$$

Where $V_{FB} = 1.25V$ and $R2 = 10k\Omega$

For example, for $V_{OUT1} = 7.5V$

$$R1 = \left(\frac{7.5V}{1.25V} - 1 \right) \times 10k\Omega = 50k\Omega$$

Therefore use a 49.9k Ω standard 1% value resistor.

NOTICE: The information in this document is subject to change without notice. Please contact MPS for current specifications. Users should warrant and guarantee that third party Intellectual Property rights are not infringed upon when integrating MPS products into any application. MPS will not assume any legal responsibility for any said applications.