



30 AMP, 75V, 3 PHASE MOSFET BRUSHLESS MOTOR CONTROLLER

4361

4707 Dey Road Liverpool, N.Y. 13088

(315) 701-6751

FEATURES:

- 75 Volt Motor Supply Voltage
- 30 Amp Output Switch Capability
- 100% Duty Cycle High Side Conduction Capable
- Shoot-Through/Cross Conduction Protection
- Hall Sensing and Commutation Circuitry on Board
- "Real" Four Quadrant Torque Control Capability
- Good Accuracy Around the Null Torque Point
- Isolated Package Design for High Voltage Isolation Plus Good Thermal Transfer
- 60°/ 120° Phasing Selectable

MIL-PRF-38534 CERTIFIED

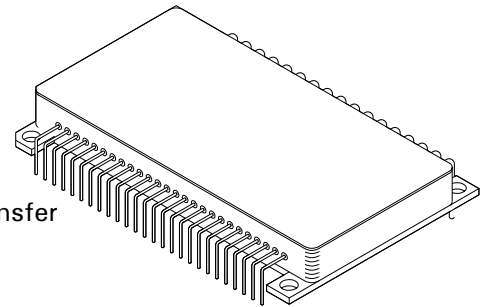

DESCRIPTION:

The MSK 4361 is a complete 3 Phase MOSFET Bridge Brushless Motor Control System in a convenient isolated hermetic package. The hybrid is capable of 30 amps of output current and 75 volts of DC bus voltage. It has the normal features for protecting the bridge. Included is all the bridge drive circuitry, hall sensing circuitry, commutation circuitry and all the current sensing and analog circuitry necessary for closed loop current mode (torque) control. When PWM'ing, the transistors are modulated in locked anti-phase mode for the tightest control and the most bandwidth. Provisions for applying different compensation schemes are included. The MSK 4361 has good thermal conductivity of the MOSFET's due to isolated package design that allows direct heat sinking of the hybrid without insulators.

BLOCK DIAGRAM



TYPICAL APPLICATIONS

- 3 Phase Brushless DC Motor Control
- Servo Control
- Fin Actuator Control
- Gimbal Control
- AZ-EL Control

PIN-OUT INFORMATION

1	REFOUT	13	E/A -	25	N/C	37	BØ
2	HALL A	14	GND	26	LGND	38	BV +
3	HALL B	15	+ Current Command	27	RTN	39	AVS
4	HALL C	16	-Current Command	28	RTN	40	AVS
5	60 / 120	17	+ 15 VIN	29	CVS	41	AØ
6	BRAKE	18	Current Monitor Out	30	CVS	42	AØ
7	CLOCK SYNC	19	-15 VIN	31	CØ	43	AV +
8	DIS	20	NC	32	CØ		
9	GND	21	NC	33	CV +		
10	NC	22	NC	34	BVS		
11	NC	23	GND	35	BVS		
12	E/A OUT	24	NC	36	BØ		

ABSOLUTE MAXIMUM RATINGS ^⑦

High Voltage Supply	75V
Current Command Input	±13.5V
Logic Inputs	-0.2V to REFOUT
REFOUT External Load	15 mA
E/A OUT External Load	5 mA
Clock SYNC Input	-0.2V to +15V
Continuous Output Current	30 Amps
Peak Output Current	41 Amps

R _{θJC} Thermal Resistance @ 125 °C	1.5 °C/W
(Output Switches)	
T _{ST} Storage Temperature Range	-65 °C to +150 °C
T _{LD} Lead Temperature Range	+300 °C
(10 Seconds)	
T _C Case Operating Temperature	
MSK4361H/E	-55 °C to +125 °C
MSK4361	-40 °C to +125 °C
T _J Junction Temperature	+150 °C

ELECTRICAL SPECIFICATIONS

Parameter	Test Conditions	Group A Subgroup	MSK 4361H/E ^③			MSK 4361 ^②			Units
			Min.	Typ.	Max.	Min.	Typ.	Max.	
INPUT CURRENT									
+15 VIN	Output PWM'ing Current Command = 0 Volts	1	-	68	85	-	68	85	mA
-15 VIN		1	-	30	40	-	30	40	mA
PWM									
Clock Free Running Frequency		4	21	22	23	20	22	24	KHz
		5,6	18.7	22	25.3	-	-	-	KHz
CLOCK SYNC INPUT									
VIL ^①		-	-	-	2.5	-	-	2.5	VOLTS
VIH ^①		-	12.5	-	-	12.5	-	-	VOLTS
Duty Cycle ^①		-	10	-	90	10	-	90	%
SYNC Frequency ^①		-	Clock +0	-	Clock +3	Clock +0	-	Clock +3	KHz
REFERENCE									
REFOUT	15mA Load	1,2,3	5.82	-	6.57	5.82	-	6.57	VOLTS
LOGIC INPUTS									
(Hall A,B,C,Brake,60°/120°,DIS)									
VIL ^①		-	-	-	0.8	-	-	0.8	VOLTS
VIH ^①		-	3.0	-	-	3.0	-	-	VOLTS
ANALOG SECTION									
Current Command Input Range ^①		-	-13.5	-	+13.5	-13.5	-	+13.5	VOLTS
Current Command Input Current ^①		-	-	-	1.5	-	-	1.5	mA
Transconductance ^⑥		4	2.70	3	3.30	2.55	3	3.45	A/V
		5,6	2.55	3	3.45	-	-	-	A/V
Offset Current	Current Command = 0 Volts	1	-25	0	25	-50	0	50	mA
		2,3	-50	0	50	-	-	-	mA
Current Monitor ^⑥		4	0.300	0.33	0.367	0.280	0.33	0.380	V/A
		5,6	0.280	0.33	0.380	-	-	-	V/A
Current Monitor Voltage Swing ^①	5mA Load	-	-12	-	+12	-12	-	+12	VOLTS
ERROR AMP									
E/A OUT Swing ^①	5mA Load	-	-12	-	+12	-12	-	+12	VOLTS
Slew Rate ^①		-	6.5	8	-	6.5	8	-	V/μSec
Gain Bandwidth Product ^①		-	-	6.5	-	-	6.5	-	MHz
Large Signal Voltage Gain ^①		-	175	275	-	175	275	-	V/mV
OUTPUT SECTION									
Voltage Drop Across Bridge (1 Upper & 1 Lower)	30 AMPS	-	-	-	1	-	-	1	VOLTS
Voltage Drop Across Bridge (1 Upper & 1 Lower)	30 AMPS @ 150 °c Junction	-	-	-	1.83	-	-	1.83	VOLTS
Leakage Current ^①	All switches off, V+ = 60V, 150 °C Junction	-	-	-	750	-	-	750	μA
Diode VSD ^①		-	-	-	2.6	-	-	2.6	VOLTS
trr ^①		-	-	280	-	-	280	-	nSec
Dead Time ^①		-	-	2	-	-	2	-	μSec

NOTES:

- ① Guaranteed by design but not tested. Typical parameters are representative of actual device performance but are for reference only.
- ② Industrial grade and "E" suffix devices shall be tested to subgroups 1 and 4 unless otherwise specified.
- ③ Military grade devices ("H" suffix) shall be 100% tested to Subgroups 1, 2, 3 and 4.
- ④ Subgroups 5 and 6 testing available upon request.
- ⑤ Subgroup 1, 4 TA = TC = +25 °C
2, 5 TA = TC = +125 °C
3, 6 TA = TC = -55 °C
- ⑥ Measurements do not include offset current at 0V current command.
- ⑦ Continuous operation at or above absolute maximum ratings may adversely effect the device performance and/or life cycle.

APPLICATION NOTES

MSK 4361 PIN DESCRIPTIONS

AV +, BV +, CV + - are the power connections from the hybrid to the bus. The pins for each phase are brought out separately and must be connected together to the V+ source externally. The external wiring to these pins should be sized according to the RMS current required by the motor. These pins should be bypassed by a high quality monolithic ceramic capacitor for high frequencies and enough bulk capacitance for keeping the V+ supply from drooping. 78 μ F of ceramic capacitance and 6200 μ F of bulk capacitance was used in the test circuit. The voltage range on these pins is from 16 volts up to 75 volts.

A \emptyset , B \emptyset & C \emptyset - are the connections to the motor phase windings from the bridge output. The wiring to these pins should be sized according to the required current by the motor. There are no short circuit provisions for these outputs. Shorts to V+ or ground from these pins must be avoided or the bridge will be destroyed.

AVS, BVS, CVS - are the return pins on the bottom of each half bridge. They are brought out separately and should be connected together externally to allow the current from each half bridge to flow through the sense resistor. The wiring on these pins should be sized according to the current requirements of the motor.

RTN - is the power return connection from the module to the bus. All ground returns connect to this point from internal to the module in a star fashion. All external ground connections to this point should also be made in a similar fashion. The V+ capacitors should be returned to this pin as close as possible. Wire sizing to this pin connection should be made according to the required current.

LGND - is an isolated ground connection to the RTN pin of the hybrid that is connected internally. For any circuitry that needs to be connected to the RTN pin without the influence of current flow through RTN should be connected at this point.

GND - is a ground pin that connects to the ground plane for all low powered circuitry inside the hybrid.

+15 VIN - is the input for applying +15 volts to run the low power section of the hybrid. This pin should be bypassed with a 10 μ F capacitor and a 0.1 μ F capacitor as close to this pin as possible.

-15 VIN - is the input for applying -15 volts to run the low power section of the hybrid. This pin should be bypassed with a 10 μ F capacitor and a 0.1 μ F capacitor as close to this pin as possible.

CURRENT COMMAND (+, -) - are differential inputs for controlling the module in current mode. Scaled at ± 3 amps per volt of input command, the bipolar input allows both forward and reverse current control capability regardless of motor commutation direction. The maximum operational command voltage should be ± 10 volts for ± 30 amps of motor current.

CURRENT MONITOR- is a pin providing a current viewing signal for external monitoring purposes. This is scaled at ± 3 amps of motor current per volt output, up to a maximum of ± 10 volts, or ± 30 amps. As ± 30 amps is exceeded, the peaks of the waveform may become clipped as the rails of the amplifiers are reached. This voltage is typically ± 12.5 volts, equating to ± 37 amps of current peaks.

E/A OUT - is the current loop error amp output connection. It is brought out for allowing various loop compensation circuits to be connected between this and E/A-.

E/A- - is the current loop error amp inverting input connection. It is brought out for allowing various loop compensation circuits to be connected between this and E/A OUT.

CLOCK SYNC- is an input for synchronizing to an external clock. The sync circuit will trigger on the edges of the applied clock and effectively shorten the period of the internal oscillator on each cycle. The frequency can be increased from a free running 22 KHz to 25 KHz maximum. The clock applied shall be 15 volts amplitude with at least a 10% duty cycle.

REFOUT - is a 6.25 volt regulated output to be used for powering the hall devices in various motors. Up to 15 mA of output current is available.

HALL A, B & C - are the hall input pins from the hall devices in the motor. These pins are internally pulled up to 6.25 volts. The halls can reflect a 120/240 degree commutation scheme or a 60/300 degree scheme.

BRAKE - is a pin for commanding the output bridge into a motor BRAKE mode. When pulled low, normal operation commences. When pulled high, the 3 high side bridge switches turn on, causing rapid deceleration of the motor and will cease motor operation until pulled high again. Logic levels for this input are TTL compatible. It is internally pulled high.

DIS - is a pin for externally disabling the output bridge. A TTL logic low will enable the bridge and a TTL logic high will disable it. It is internally pulled up by a 100 μ Amp pullup.

60/120 - is a pin for selecting the orientation of the commutation scheme of the motor. A high state will produce 60/300 degree commutation, whereas a low state will produce 120/240 degree commutation. Logic levels for this input are TTL compatible. It is internally pulled high.

APPLICATION NOTES CONTINUED

COMMUTATION TRUTH TABLE

HALL SENSOR PHASING						ICOMMAND = POS.			ICOMMAND = NEG.			BRAKE
120°			60°									
HALL A	HALL B	HALL C	HALL A	HALL B	HALL C	AØ	BØ	CØ	AØ	BØ	CØ	
1	0	0	1	0	0	H	-	L	L	-	H	0
1	1	0	1	1	0	-	H	L	-	L	H	0
0	1	0	1	1	1	L	H	-	H	L	-	0
0	1	1	0	1	1	L	-	H	H	-	L	0
0	0	1	0	0	1	-	L	H	-	H	L	0
1	0	1	0	0	0	H	L	-	L	H	-	0
1	1	1	1	0	1	-	-	-	-	-	-	0
0	0	0	0	1	0	-	-	-	-	-	-	0
X	X	X	X	X	X	L	L	L	L	L	L	1

1 = High Level
 0 = Low Level
 X = Don't Care

H = SOURCE
 L = SINK
 - = OPEN

NOTE: Because of the true 4 quadrant method of output switching, the output switches will PWM between the ICOMMAND POSITIVE and ICOMMAND NEGATIVE states, with the average percentage based on ICOMMAND being a positive voltage and a negative voltage. With a zero voltage ICOMMAND, the output switches will modulate with exactly a 50% duty cycle between the ICOMMAND POSITIVE and ICOMMAND NEGATIVE states.

APPLICATION NOTES CONTINUED

BUS VOLTAGE FILTER CAPACITORS

The size and placement of the capacitors for the DC bus has a direct bearing on the amount of noise filtered and also on the size and duration of the voltage spikes seen by the bridge. What is being created is a series RLC tuned circuit with a resonant frequency that is seen as a damped ringing every time one of the transistors switches. For the resistance, wire resistance, power supply impedance and capacitor ESR all add up for the equivalent lumped resistance in the circuit. The inductance can be figured at about 30 nH per inch from the power supply. Any voltage spikes are on top of the bus voltage and the back EMF from the motor. All this must be taken into account when designing and laying out the system. If everything has been minimized, there is another solution. A second capacitance between 5 and 10 times the first capacitor and it should either have some ESR or a resistor can be added in series with the second capacitor to help damp the voltage spikes.

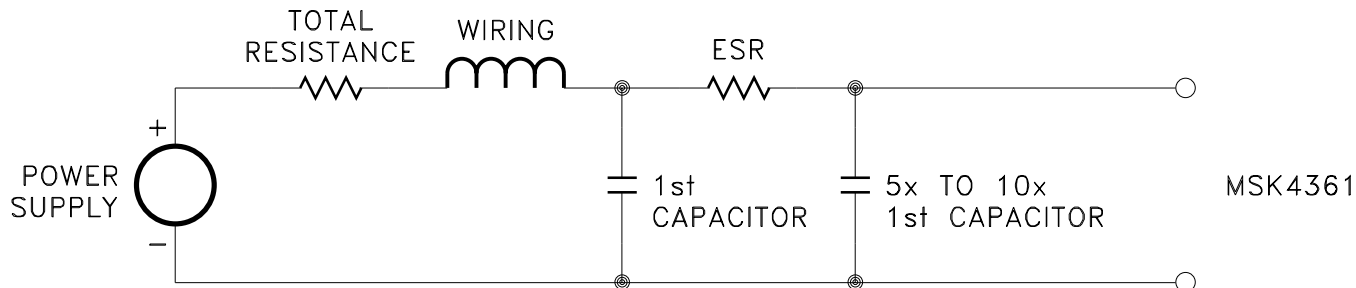

Be careful of the ripple current in all the capacitors. Excessive ripple current, beyond what the capacitors can handle, will destroy the capacitors.

GENERAL LAYOUT

Good PC layout techniques are a must. Ground planes for the analog circuitry must be used and should be tied back to the small pin grounds 9, 14 and 23. Additional ground, pin 26 is an isolated ground that connects internally directly back to the main DC bus ground pin 27. This can be used as necessary for voltage sensing, etc.

LOW POWER STARTUP

When starting up a system utilizing the MSK 4361 for the first time, there are a few things to keep in mind. First, because of the small size of the module, short circuiting the output phases either to ground or the DC bus will destroy the bridge. The current limiting and control only works for current actually flowing through the bridge. The current sense resistor has to see the current in order for the electronics to control it. If possible, for startup use a lower voltage and lower current power supply to test out connections and the low current stability. With a limited current supply, even if the controller locks up, the dissipation will be limited. By observing the E/A OUT pin which is the error amp output, much can be found out about the health and stability of the system. An even waveform with some rounded triangle wave should be observed. As current goes up, the DC component of the waveform should move up or down. At full current (with a regular supply) the waveform should not exceed +8 volts positive peak, or -8 volts negative peak. Some audible noise will be heard which will be the commutation frequency. If the motor squeals, there is instability and power should be removed immediately unless power dissipation isn't excessive due to limited supply current. For compensation calculations, refer to the block diagram for all information to determine the amplifier gain for loop gain calculations.

MSK4361 TEST CIRCUIT

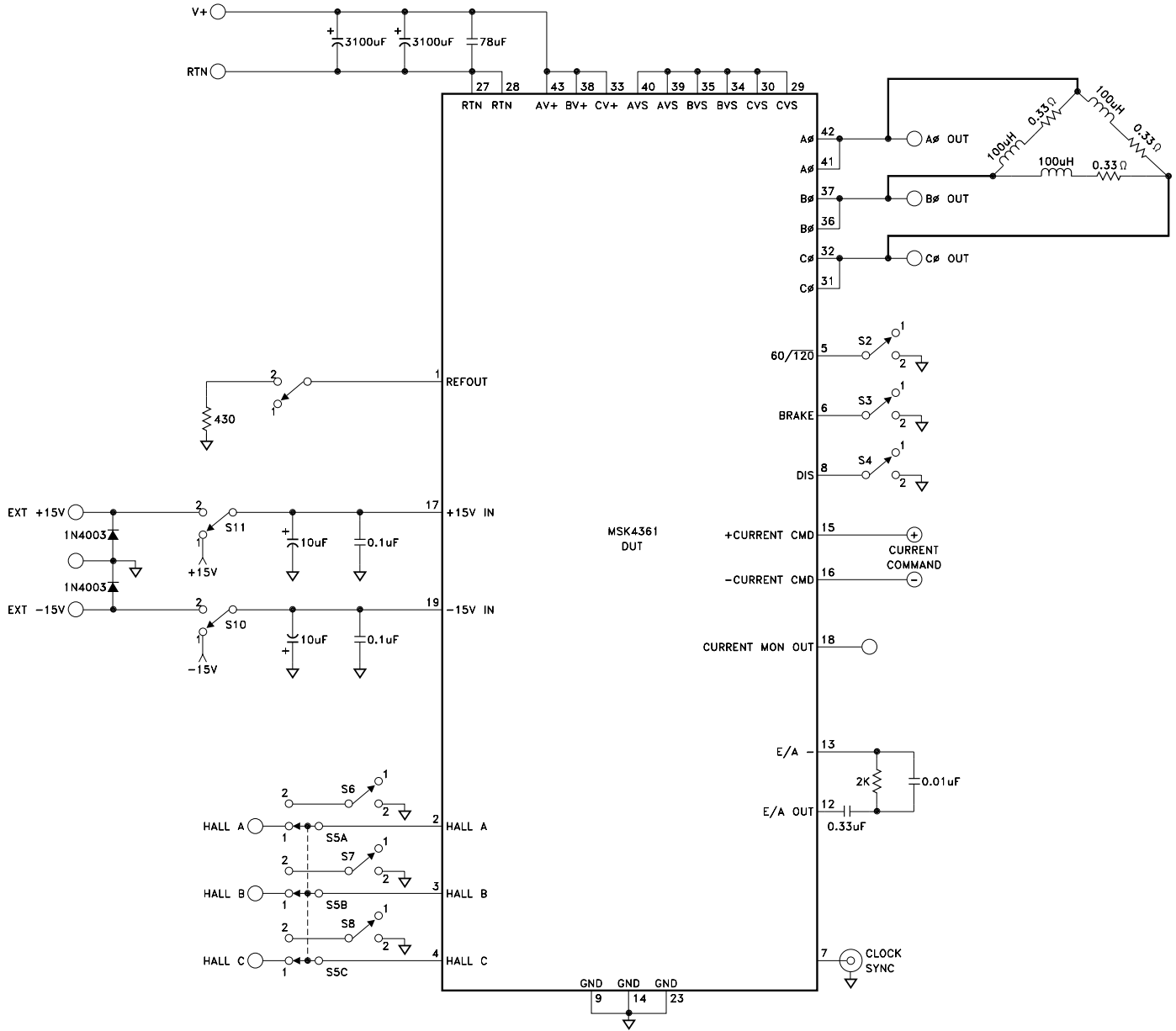

TYPICAL TEST SCHEMATIC

MECHANICAL SPECIFICATIONS

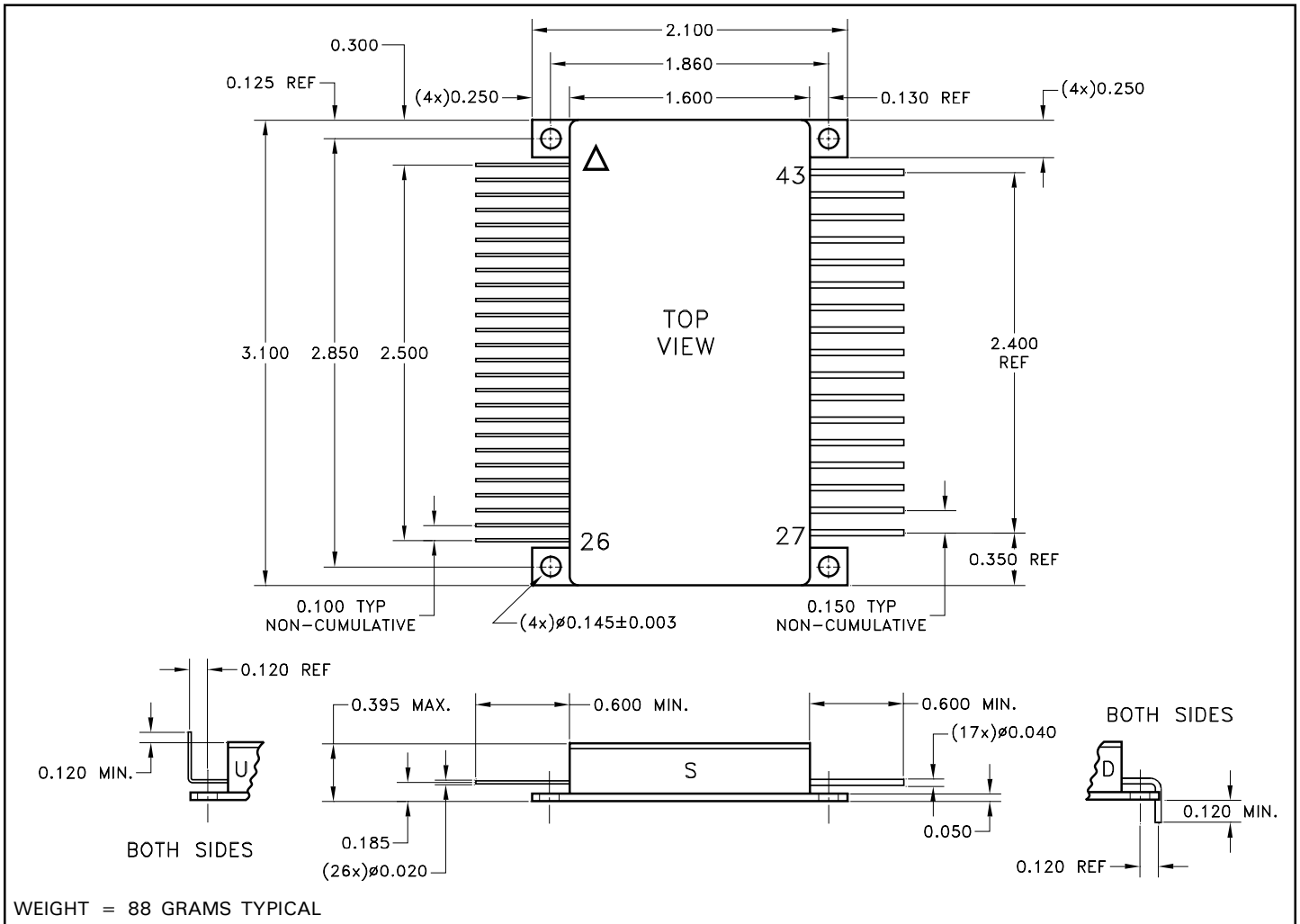

NOTE: ALL DIMENSIONS ARE ± 0.010 INCHES UNLESS OTHERWISE LABELED.
ESD Triangle Indicates Pin 1.

ORDERING INFORMATION

MSK4361 H U

LEAD CONFIGURATION

S = STRAIGHT, U = BENT UP, D = BENT DOWN

SCREENING

BLANK = INDUSTRIAL, E = EXTENDED RELIABILITY

H = MIL-PRF-38534 CLASS H

GENERAL PART NUMBER

THE ABOVE EXAMPLE IS A MILITARY GRADE HYBRID WITH LEADS BENT UP.

M.S. Kennedy Corp.

4707 Dey Road, Liverpool, New York 13088

Phone (315) 701-6751

FAX (315) 701-6752

www.mskennedy.com

The information contained herein is believed to be accurate at the time of printing. MSK reserves the right to make changes to its products or specifications without notice, however, and assumes no liability for the use of its products. Please visit our website for the most recent revision of this datasheet.