

Product Description

Stanford Microdevices' NGA-386 is a high performance Gallium Arsenide Heterojunction Bipolar Transistor MMIC Amplifier. Designed with InGaP process technology for improved reliability, a Darlington configuration is utilized for broadband performance up to 5 GHz. The heterojunction increases breakdown voltage and minimizes leakage current between junctions. Cancellation of emitter junction non-linearities results in higher suppression of intermodulation products.

Small Signal Gain vs. Frequency

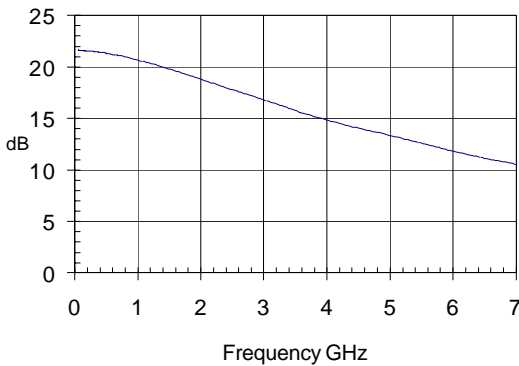

NGA-386

DC-5000 MHz, Cascadable GaAs HBT MMIC Amplifier



Product Features

- High Gain: 18.9dB at 1950MHz
- Cascadable 50 ohm: 1.2:1 VSWR
- Patented GaAs HBT Technology
- Operates from Single Supply
- Low Thermal Resistance Package
- Unconditionally Stable

Applications

- Cellular, PCS, CDPD
- Wireless Data, SONET

Symbol	Parameters: Test Conditions: $Z_0 = 50 \text{ Ohms}$, $I_D = 35 \text{ mA}$, $T = 25^\circ\text{C}$		Units	Min.	Typ.	Max.
P_{1dB}	Output Power at 1dB Compression	f = 850 MHz f = 1950 MHz f = 2400 MHz	dBm dBm dBm		14.5 15.0 15.6	
IP_3	Third Order Intercept Point Power out per tone = 0 dBm	f = 850 MHz f = 1950 MHz f = 2400 MHz	dBm dBm dBm		25.8 27.0 27.0	
S_{21}	Small Signal Gain	f = 850 MHz f = 1950 MHz f = 2400 MHz	dB dB dB		20.9 18.9 18.0	
Bandwidth	3dB Bandwidth		MHz		2000	
S_{11}	Input VSWR	f = DC - 5000 MHz	-		1.2:1	
S_{22}	Output VSWR	f = DC - 5000 MHz	-		1.3:1	
S_{12}	Reverse Isolation	f = 850 MHz f = 1950 MHz f = 2400 MHz	dB dB dB		23.4 22.2 21.6	
NF	Noise Figure	f = 2000 MHz	dB		2.7	
V_D	Device Voltage		V		4.0	
$R_{th, j-l}$	Thermal Resistance (junction - lead)		$^\circ\text{C/W}$		144	

The information provided herein is believed to be reliable at press time. Stanford Microdevices assumes no responsibility for inaccuracies or omissions. Stanford Microdevices assumes no responsibility for the use of this information, and all such information shall be entirely at the user's own risk. Prices and specifications are subject to change without notice. No patent rights or licenses to any of the circuits described herein are implied or granted to any third party. Stanford Microdevices does not authorize or warrant any Stanford Microdevices product for use in life-support devices and/or systems. Copyright 2000 Stanford Microdevices, Inc. All worldwide rights reserved.

Absolute Maximum Ratings

Operation of this device above any one of these parameters may cause permanent damage.

Bias Conditions should also satisfy the following expression: $I_D V_D (max) < (T_J - T_{OP})/R_{th,j-l}$

Parameter	Value	Unit
Supply Current	90	mA
Device Voltage	6.0	V
Operating Temperature	-40 to +85	°C
Maximum Input Power	+10	dBm
Storage Temperature Range	-40 to +150	°C
Operating Junction Temperature	+150	°C

Key parameters, at typical operating frequencies:

Parameter	Typical 25°C	Unit	Test Condition
			($I_b = 35mA$, unless otherwise noted)
500 MHz			
Gain	21.3	dB	Tone spacing = 1 MHz, Pout per tone = 0dBm
Output IP3	25.1	dBm	
Output P1dB	14.6	dBm	
Input Return Loss	26.8	dB	
Isolation	23.6	dB	
850 MHz			
Gain	20.9	dB	Tone spacing = 1 MHz, Pout per tone = 0dBm
Output IP3	25.8	dBm	
Output P1dB	14.5	dBm	
Input Return Loss	24.8	dB	
Isolation	23.4	dB	
1950 MHz			
Gain	18.9	dB	Tone spacing = 1 MHz, Pout per tone = 0dBm
Output IP3	27.0	dBm	
Output P1dB	15.0	dBm	
Input Return Loss	22.0	dB	
Isolation	22.2	dB	
2400 MHz			
Gain	18.0	dB	Tone spacing = 1 MHz, Pout per tone = 0dBm
Output IP3	27.0	dBm	
Output P1dB	15.6	dBm	
Input Return Loss	21.0	dB	
Isolation	21.6	dB	

The information provided herein is believed to be reliable at press time. Stanford Microdevices assumes no responsibility for inaccuracies or omissions. Stanford Microdevices assumes no responsibility for the use of this information, and all such information shall be entirely at the user's own risk. Prices and specifications are subject to change without notice. No patent rights or licenses to any of the circuits described herein are implied or granted to any third party. Stanford Microdevices does not authorize or warrant any Stanford Microdevices product for use in life-support devices and/or systems. Copyright 2000 Stanford Microdevices, Inc. All worldwide rights reserved.

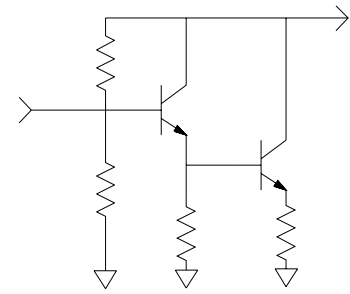
Pin #	Function	Description	Device Schematic
1	RF IN	RF input pin. This pin requires the use of an external DC blocking capacitor chosen for the frequency of operation.	
2	GND	Connection to ground. For best performance use via holes (as close to ground leads as possible) to reduce lead inductance.	
3	RF OUT/BIAS	RF output and bias pin. DC voltage is present on this pin, therefore a DC blocking capacitor is necessary for proper operation.	
4	GND	Same as Pin 2.	

Application Schematic for Operation at 850 MHz

Recommended Bias Resistor Values				
Supply Voltage(Vs)	5V	8V	9V	12V
Rbias (Ohms)	30	120	150	240

For 9V operation or higher, a resistor with a power handling capability of 1/2W or greater is recommended.

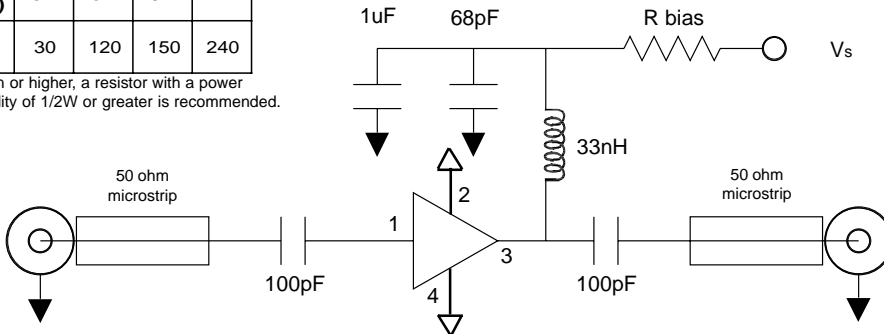

Application Schematic for Operation at 1950 MHz

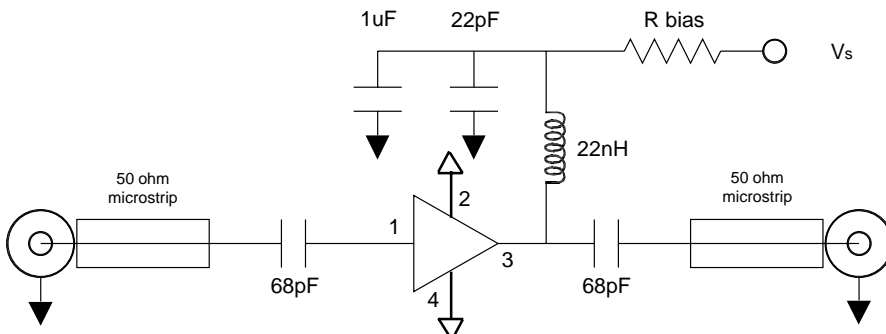

The information provided herein is believed to be reliable at press time. Stanford Microdevices assumes no responsibility for inaccuracies or omissions. Stanford Microdevices assumes no responsibility for the use of this information, and all such information shall be entirely at the user's own risk. Prices and specifications are subject to change without notice. No patent rights or licenses to any of the circuits described herein are implied or granted to any third party. Stanford Microdevices does not authorize or warrant any Stanford Microdevices product for use in life-support devices and/or systems. Copyright 2000 Stanford Microdevices, Inc. All worldwide rights reserved.

S-parameters over frequency, at 25°C

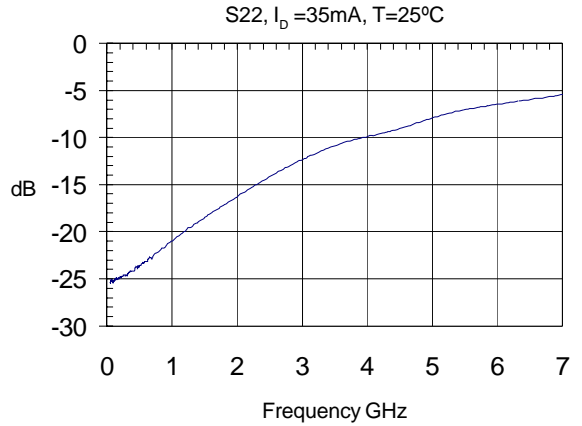
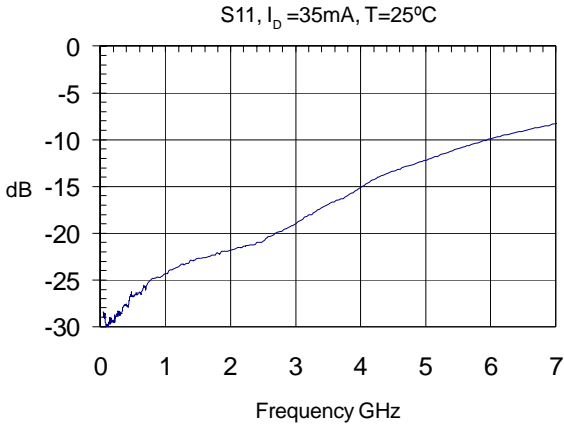
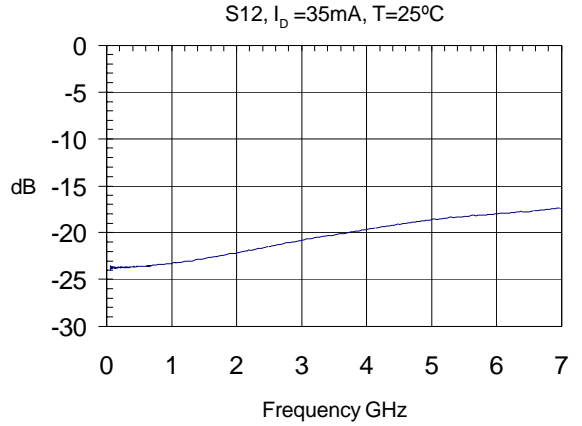
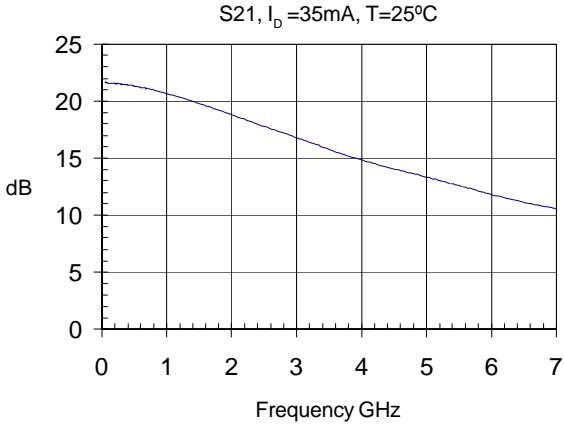

The information provided herein is believed to be reliable at press time. Stanford Microdevices assumes no responsibility for inaccuracies or omissions. Stanford Microdevices assumes no responsibility for the use of this information, and all such information shall be entirely at the user's own risk. Prices and specifications are subject to change without notice. No patent rights or licenses to any of the circuits described herein are implied or granted to any third party. Stanford Microdevices does not authorize or warrant any Stanford Microdevices product for use in life-support devices and/or systems. Copyright 2000 Stanford Microdevices, Inc. All worldwide rights reserved.

Typical S-Parameters, $I_D = 35mA$ (No external matching, de-embedded to device leads)

Freq GHz	S11		S21			S12			S22	
	mag	Ang	dB	mag	Ang	dB	mag	Ang	mag	Ang
0.05	0.038	180	21.7	12.126	178	-23.6	0.066	0	0.054	-180
0.10	0.032	172	21.6	12.024	176	-23.7	0.066	1	0.055	-179
0.20	0.034	156	21.5	11.923	171	-23.7	0.065	2	0.057	-177
0.30	0.037	147	21.5	11.854	167	-23.7	0.065	2	0.059	-174
0.40	0.042	136	21.4	11.760	162	-23.7	0.066	3	0.062	-174
0.50	0.046	130	21.3	11.656	158	-23.6	0.066	4	0.066	-173
0.60	0.048	123	21.2	11.489	154	-23.6	0.066	5	0.070	-174
0.70	0.051	118	21.1	11.340	150	-23.5	0.067	5	0.073	-173
0.80	0.057	115	21.0	11.163	145	-23.4	0.067	6	0.079	-175
0.90	0.058	111	20.8	11.020	142	-23.4	0.068	6	0.082	-176
1.00	0.061	108	20.7	10.818	138	-23.3	0.068	7	0.089	-177
1.10	0.064	104	20.5	10.589	134	-23.2	0.069	7	0.095	-178
1.20	0.066	101	20.3	10.371	130	-23.1	0.070	8	0.101	-180
1.30	0.068	99	20.2	10.220	127	-23.0	0.071	9	0.105	179
1.40	0.072	99	20.0	10.012	123	-22.9	0.072	9	0.112	177
1.50	0.073	96	19.8	9.750	119	-22.8	0.073	9	0.119	175
1.60	0.074	93	19.6	9.514	115	-22.6	0.074	9	0.126	173
1.70	0.075	93	19.4	9.367	113	-22.5	0.075	10	0.131	171
1.80	0.079	93	19.2	9.129	109	-22.4	0.076	10	0.139	169
1.90	0.080	92	19.0	8.907	106	-22.2	0.077	10	0.146	167
2.00	0.081	91	18.8	8.682	103	-22.1	0.078	10	0.154	164
2.20	0.085	91	18.4	8.321	97	-21.9	0.081	10	0.170	160
2.40	0.090	92	18.0	7.899	91	-21.6	0.083	10	0.188	154
2.60	0.096	94	17.6	7.581	86	-21.4	0.086	10	0.205	149
2.80	0.105	97	17.2	7.217	80	-21.1	0.089	9	0.224	144
3.00	0.113	100	16.8	6.916	75	-20.8	0.091	9	0.241	140
3.20	0.124	102	16.4	6.643	71	-20.6	0.093	8	0.258	136
3.40	0.136	103	16.0	6.289	65	-20.3	0.096	7	0.278	132
3.60	0.146	104	15.6	6.006	61	-20.1	0.099	7	0.293	128
3.80	0.158	105	15.2	5.735	57	-19.9	0.101	5	0.309	124
4.00	0.174	107	14.9	5.542	53	-19.7	0.104	5	0.318	122
4.50	0.215	105	14.1	5.041	42	-19.1	0.111	1	0.353	117
5.00	0.246	103	13.3	4.641	31	-18.6	0.117	-2	0.402	111
5.50	0.284	101	12.6	4.251	21	-18.3	0.122	-7	0.445	103
6.00	0.319	97	11.8	3.903	12	-18.0	0.126	-11	0.475	97
6.50	0.353	92	11.1	3.599	3	-17.7	0.130	-14	0.503	91
7.00	0.386	87	10.5	3.364	-6	-17.4	0.135	-19	0.534	84

The information provided herein is believed to be reliable at press time. Stanford Microdevices assumes no responsibility for inaccuracies or omissions. Stanford Microdevices assumes no responsibility for the use of this information, and all such information shall be entirely at the user's own risk. Prices and specifications are subject to change without notice. No patent rights or licenses to any of the circuits described herein are implied or granted to any third party. Stanford Microdevices does not authorize or warrant any Stanford Microdevices product for use in life-support devices and/or systems. Copyright 2000 Stanford Microdevices, Inc. All worldwide rights reserved.



Caution: ESD sensitive
Appropriate precautions in handling, packaging and testing devices must be observed.

Part Number Ordering Information

Part Number	Reel Size	Devices/Reel
NGA-386	7"	1000

Part Symbolization

The part will be symbolized with a "N3" designator on the top surface of the package.

Package Dimensions

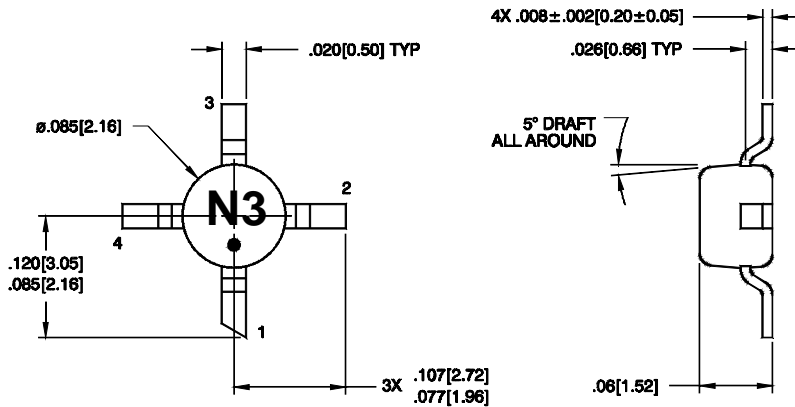

PCB Pad Layout

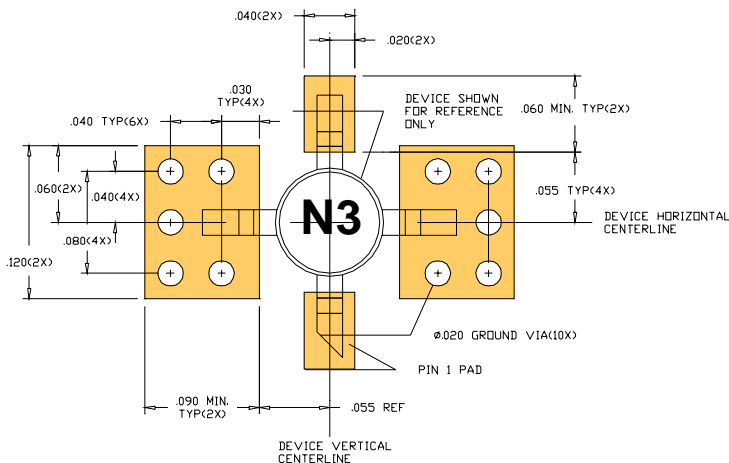

The information provided herein is believed to be reliable at press time. Stanford Microdevices assumes no responsibility for inaccuracies or omissions. Stanford Microdevices assumes no responsibility for the use of this information, and all such information shall be entirely at the user's own risk. Prices and specifications are subject to change without notice. No patent rights or licenses to any of the circuits described herein are implied or granted to any third party. Stanford Microdevices does not authorize or warrant any Stanford Microdevices product for use in life-support devices and/or systems. Copyright 2000 Stanford Microdevices, Inc. All worldwide rights reserved.

Component Tape and Reel Packaging

Tape Dimensions

For 86 Outline

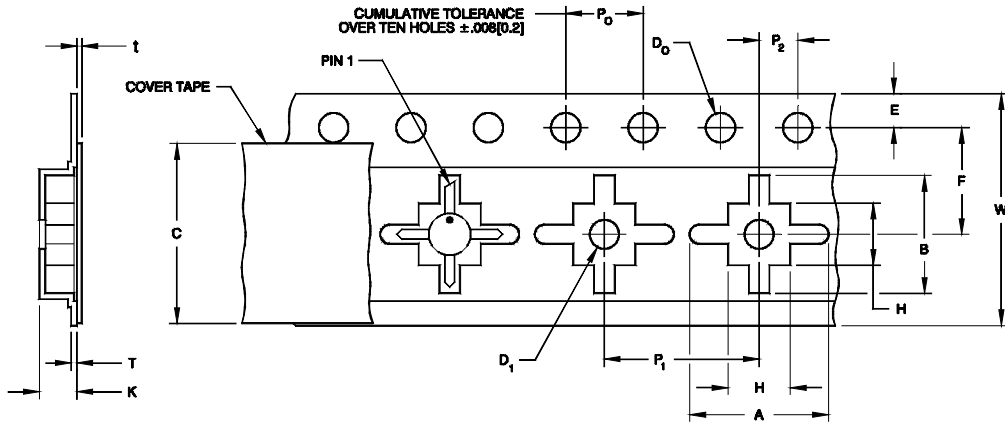

DESCRIPTION		SYMBOL	SIZE (MM)
Cavity	Length	A	6.10 ± 0.10
	Width	B	6.20 ± 0.10
	Socket	H	3.10 ± 0.10
	Depth	K	2.00 ± 0.10
	Pitch	P	8.00 ± 0.10
	Bottom Hole diameter	D ₁	1.50 min.
Perforation	Diameter	D ₀	1.50 ± 0.10
	Pitch	P ₀	4.00 ± 0.10
	Position	E	1.75 ± 0.10
Cover Tape	Width	C	9.10 ± 0.25
	Tape Thickness	t	0.05 ± 0.01
Carrier Tape	Width	W	12.00 ± 0.30
	Tape Thickness	T	0.30 ± 0.05
Distance	Cavity to Perforation (Width Direction)	F	5.50 ± 0.05
	Cavity to Perforation (Length Direction)	P ₂	2.00 ± 0.05

The information provided herein is believed to be reliable at press time. Stanford Microdevices assumes no responsibility for inaccuracies or omissions. Stanford Microdevices assumes no responsibility for the use of this information, and all such information shall be entirely at the user's own risk. Prices and specifications are subject to change without notice. No patent rights or licenses to any of the circuits described herein are implied or granted to any third party. Stanford Microdevices does not authorize or warrant any Stanford Microdevices product for use in life-support devices and/or systems. Copyright 2000 Stanford Microdevices, Inc. All worldwide rights reserved.