

# High Speed GaAlAs Infrared Emitter

## OPE5685

The **OPE5685** is GaAlAs infrared emitting diode that is designed for high power, low forward voltage and high speed rise / fall time.

This device is optimized for speed and efficiency at emission wavelength 850nm and has a high radiant efficiency over a wide range of forward current. This device is packaged T1-3/4 plastic package and has wide beam angle with lensed package and cup frame. Especially this device is suited as the emitter of data transmission without cable.

### FEATURES

- High speed : 25ns rise time
- 850nm wavelength
- Wide beam angle
- Low forward voltage
- High power and high reliability
- Available for pulse operating

### APPLICATIONS

- Emitter of IrDA
- IR Audio and Telephone
- High speed IR communication
- IR LANs
- Available for wireless digital data transmission

### STORAGE

- Condition : 5°C~35°C,R.H.60%
- Terms : within 3 months from production date
- Remark : Once the package is opened, the products should be used within a day. Otherwise, it should be keeping in a damp proof box with desiccants.

\* Please take proper steps in order to secure reliability and safety in required conditions and environments for this device.

DIMENSIONS(Unit : mm)

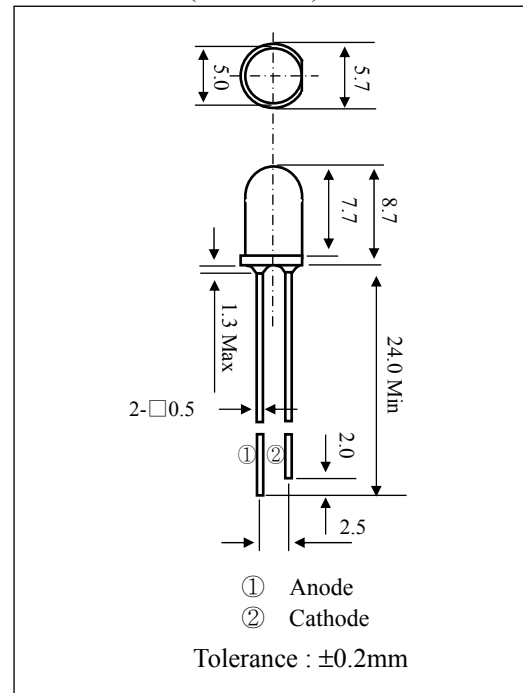

### MAXIMUM RATINGS

(Ta=25°C)

Item	Symbol	Rating	Unit
Power Dissipation	$P_D$	150	MW
Forward current	$I_F$	100	MA
Pulse forward current	$I_{FP}$	1.0	A
Reverse voltage	$V_R$	4.0	V
Operating temp.	$T_{opr.}$	-25~+85	°C
Soldering temp.	$T_{sol.}$	260.	°C

\*1. Duty ratio = 1/100, pulse width=0.1ms.

\*2. Lead Soldering Temperature (2mm from case for 5sec.).

### ELECTRO-OPTICAL CHARACTERISTICS

(Ta=25°C)

Item	Symbol	Conditions	Min.	Typ.	Max.	Unit
Forward voltage	$V_F$	$I_F=50mA$		1.5	2.0	V
Reverse current	$I_R$	$V_R=4V$			10	μA
Capacitance	$C_t$	$f=1MHz$		20		pF
Radiant intensity	$I_e$	$I_F=50mA$		50		mW/sr
Peak emission wavelength	$\lambda_p$	$I_F=50mA$		850		nm
Spectral bandwidth 50%	$\Delta\lambda$	$I_F=50mA$		45		nm
Half angle	$\Delta\theta$	$I_F=50mA$		±22		deg.
Optical rise & fall time(10%~90%)	tr/tf	$I_F=50mA$		25/13		ns
Cut off frequency	$f_c$	$I_F=50mA$ DC +10mA p-p		14		MHz

\*3.  $10\log(P_o(f_c \text{ MHz})/P_o(0.1 \text{ MHz}))=-3$

- **FORWARD CURRENT Vs. AMBIENT TEMP.**

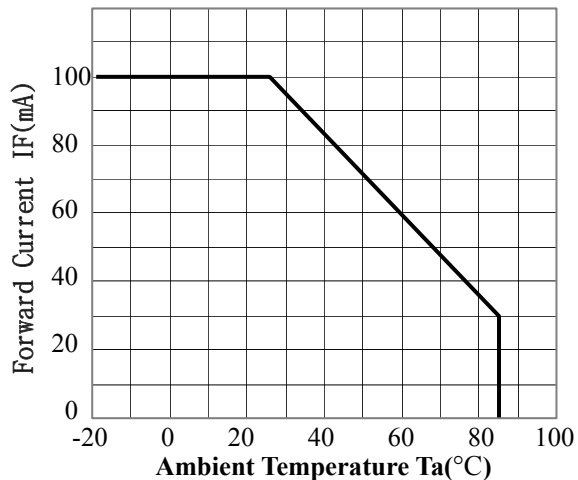

- **RADIANT INTENSITY Vs. FORWARD CURRENT.**

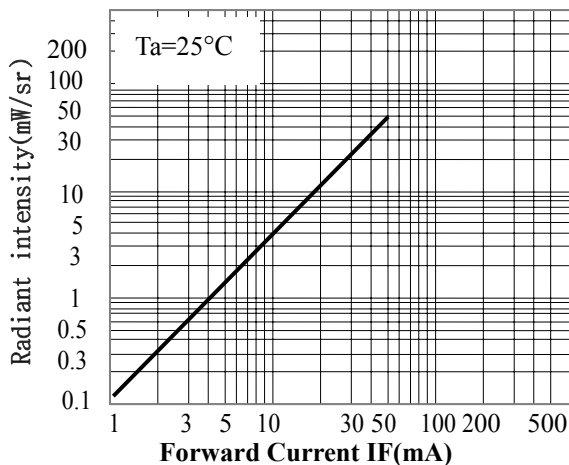

- **RELATIVE RADIANT INTENSITY Vs. AMBIENT TEMP.**

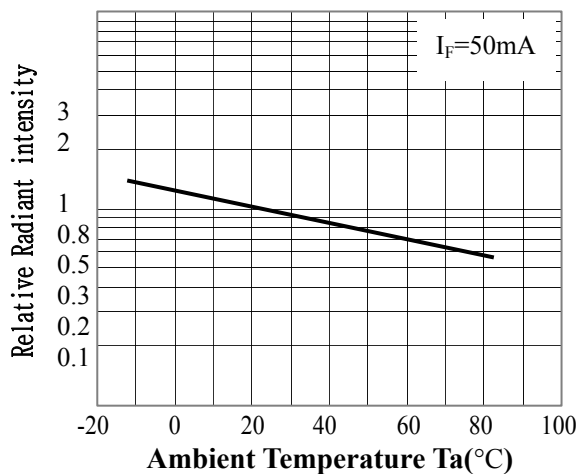

- **RELATIVE RADIANT INTENSITY Vs. EMISSION WAVELENGTH.**

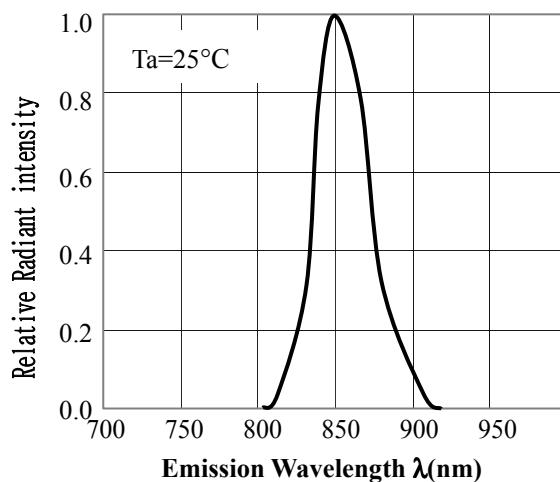

- **FORWARD CURRENT Vs. FORWARD VOLTAGE**

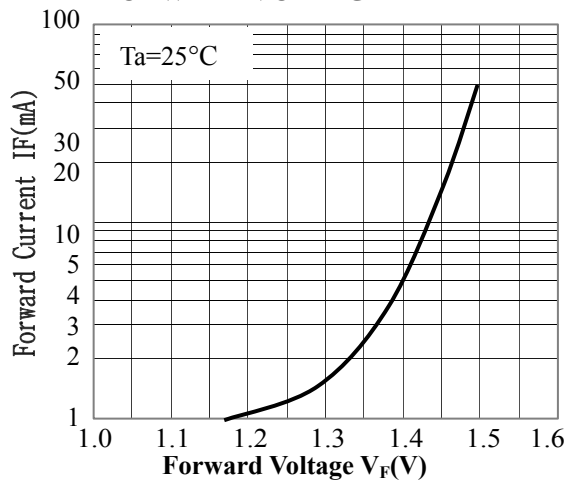

- **ANGULAR DISPLACEMENT Vs. RELATIVE RADIANT INTENSITY**

