

**INTRODUCTION**

The S1A0497X01 is a monolithic integrated circuit designed for the FM front end of portable radio cassettes or music centers. It consists of RF AMP, local OSC buffer and mixer. Compared with conventional types, it is improved in the following characteristics:

- Low supply voltage
- Strong input
- Spurious radiation

**FEATURES**

- Wide supply voltage range:  $V_{CC} = 1.6V - 6.0V$
- Low local oscillation stop voltage:  $V_{STOP} = 0.9V$  (Typ)
- Improved inter-modulation characteristics by double balanced type mixer circuit
- Low spurious radiation
- Built-in clamping diode in the mixer output stage

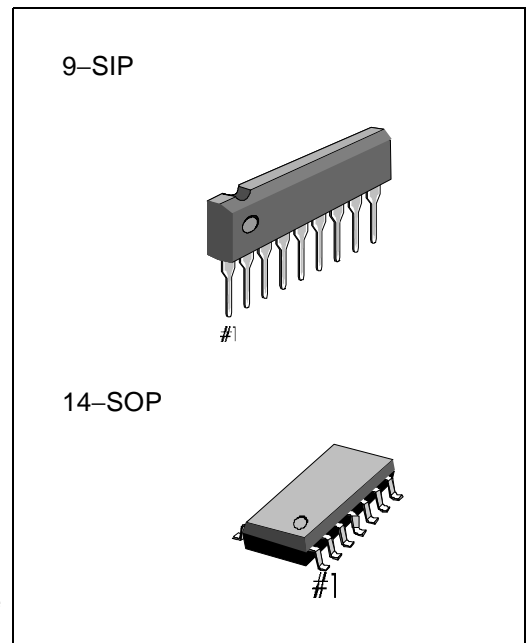

**ORDERING INFORMATION**

Device	Package	Operating Temperature
S1A0497X01-I0B0	9-SIP	-25°C - +75°C
S1A0497X01-S0B0	14-SOP	

## BLOCK DIAGRAM

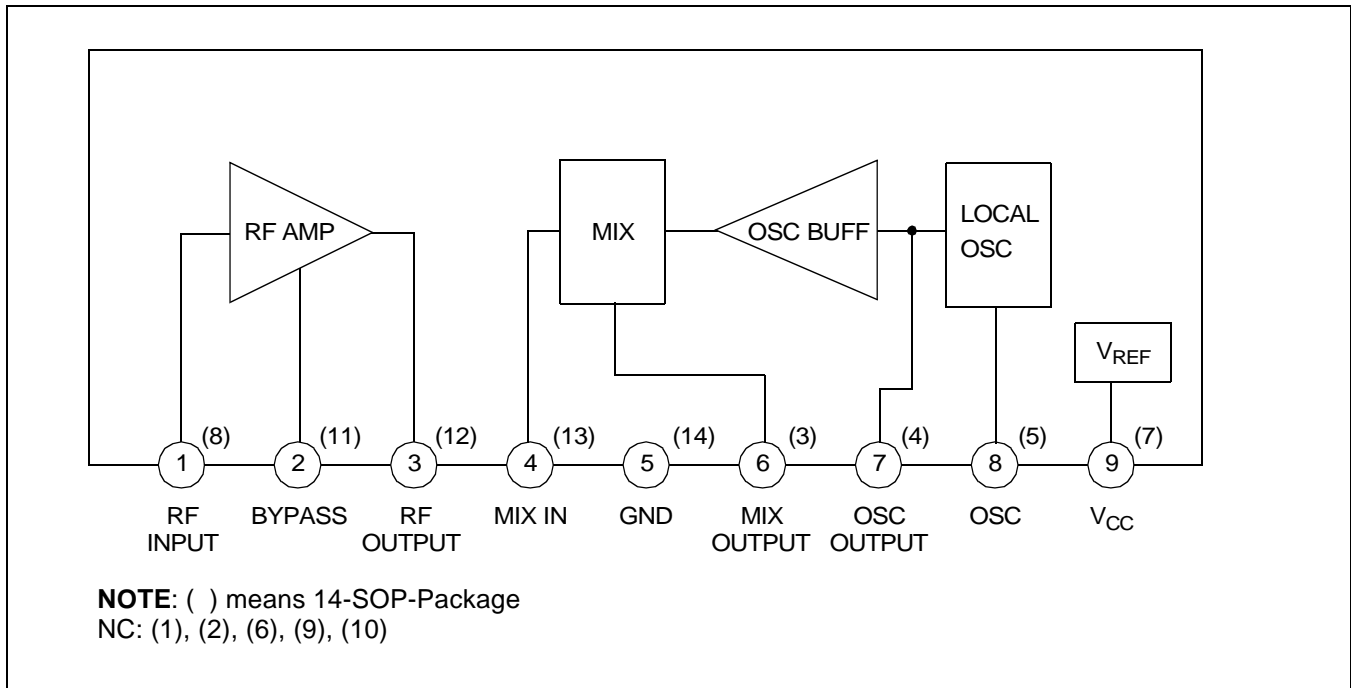
ABSOLUTE MAXIMUM RATINGS ( $T_a = 25^\circ\text{C}$ )

Characteristic	Symbol	Value	Unit
Supply Voltage	$V_{CC}$	8	V
Power Dissipation	$P_D$	S1A0497X(9-SIP)	600
		S1A0497X(14-SOP)	300
Operating Temperature	$T_{OPR}$	-25 - +75	$^\circ\text{C}$
Storage Temperature	$T_{STG}$	-55 - +150	$^\circ\text{C}$

**NOTE:** Derated above  $T_a = 25^\circ\text{C}$  in the proportion of 4mW/ $^\circ\text{C}$

**ELECTRICAL CHARACTERISTICS**(Ta = 25 °C ( V<sub>CC</sub> = 5 V, f = 98MHz, fm = 1kHz, Δf = ± 22.5KHz, unless otherwise specified)

Characteristic	Symbol	Test Conditions	Min.	Typ.	Max.	Unit
Quiescent Circuit Current	I <sub>CCQ</sub>	V <sub>L</sub> = 0	–	5.0	8.0	mA
-3dB Limiting Sensitivity	V <sub>I(LIM)</sub>	V <sub>D</sub> (V <sub>I</sub> = 60 dBμ)-3dB Down	–	3.0	7.0	dBμ
Conversion Gain	G <sub>V</sub>	V <sub>I</sub> = 60 dBμ	25	31	–	dB
Usable Sensitivity	S <sub>USA</sub>	S/N = 30dB	–	11	–	dBμ
Oscillation Voltage	V <sub>OSC</sub>	f <sub>OSC</sub> = 108MHz	90	165	250	mV
Oscillation Stop Voltage	V <sub>STOP</sub>	–	–	0.9	1.3	V

TEST CIRCUIT

( $I_{CCQ}$ ,  $V_{I(LIM)}$ ,  $S_{USA}$ ,  $G_V$ ,  $V_{OSC}$ ,  $V_{STOP}$ )

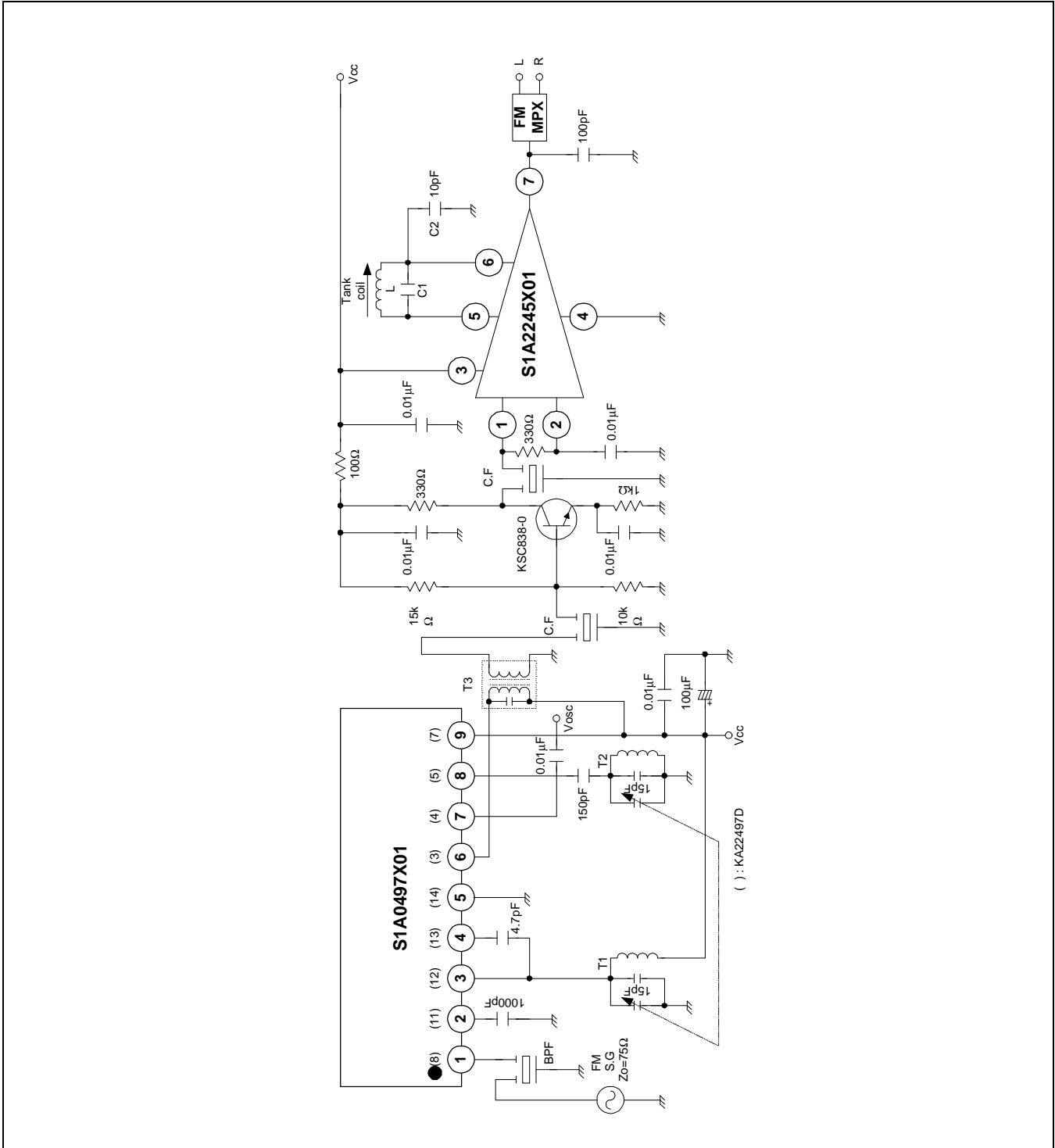

**COIL SPECIFICATIONS (BOTTOM VIEW)**

T1 (L1) FM RF

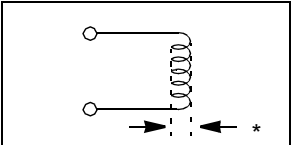

f (MHz)	Q <sub>O</sub>	Turns
98	100	4

\* In a Diameter of 5.5 mm

0.8 mm φ UEW

T2 (L2) FM OSC

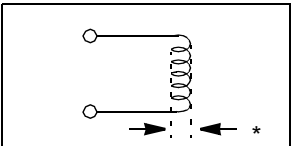

f (MHz)	Q <sub>O</sub>	Turns
98	100	3

\* In a Diameter of 5.5 mm

0.8 mm φ UEW

T3 FM IFT

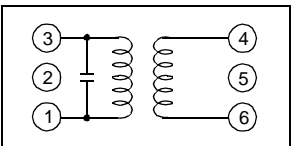

CO (pF)	f (MHz)	Q <sub>O</sub>	Turns	
1 - 3		1 - 3	1 - 3	4 - 6
75	10.7	115	12	1

KOREA TOKO

0.12 mm φ UEW

T1 (L1) FM RF

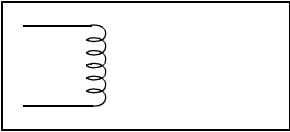

KSS-SP1

F (MHz)	Qo	Turns	D	WIRE	KWANG SUNG PART NO
98	100	4	5.5ϕ	0.8ϕ	KSS-SPI

T2 (L2) FM RF OSC

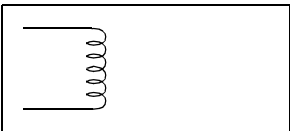

KSS-SP2

F (MHz)	Qo	Turns	D	WIRE	KWANG SUNG PART NO
98	100	3	5.5ϕ	0.8ϕ	KSS-SP2

T3 FM IFT

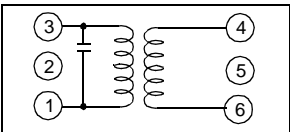

KSI-FA1

C <sub>0</sub> (pF)	F (MHz)	Q <sub>0</sub>	Turns		KWANG SUNG PART NO
1 - 3		1 - 3	1 - 3	4 - 6	
75	10.7	115	12	1	KSI-FA1

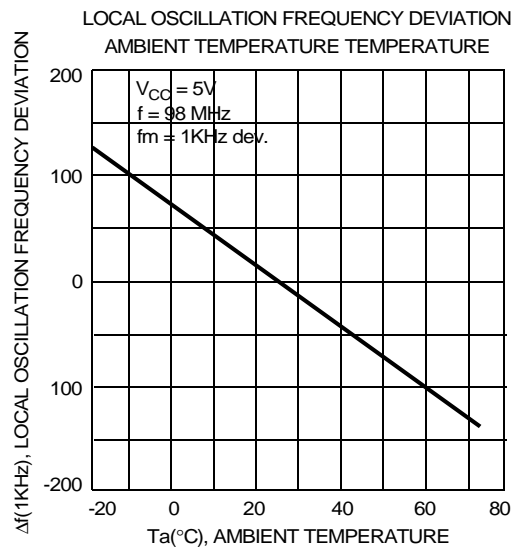
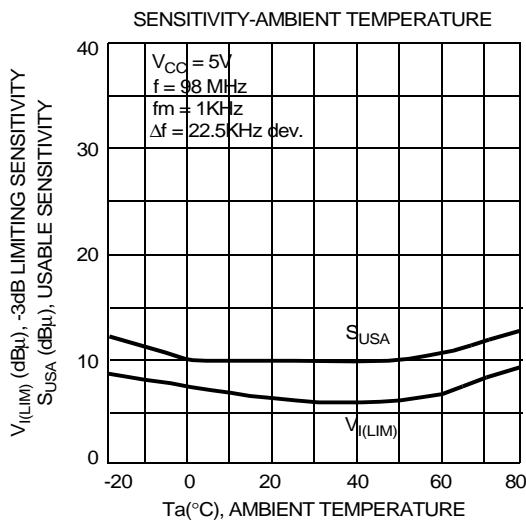
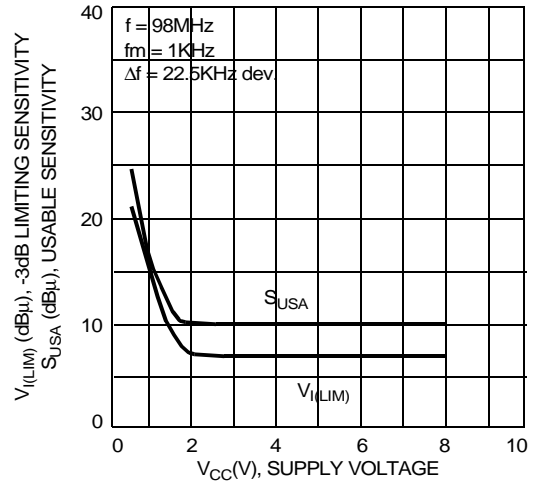
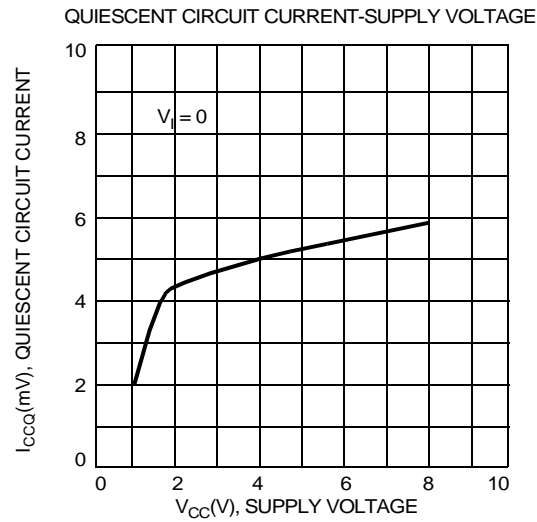
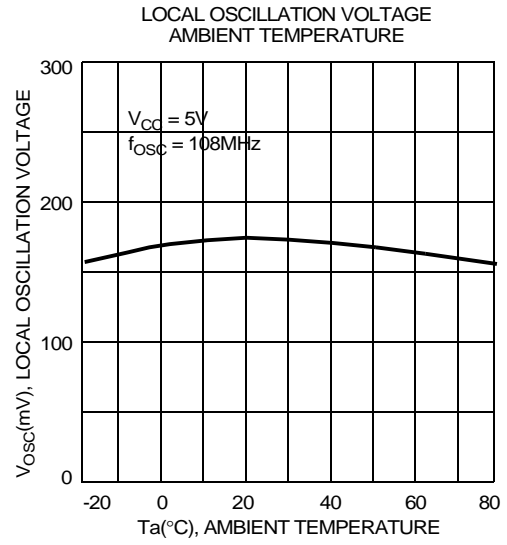
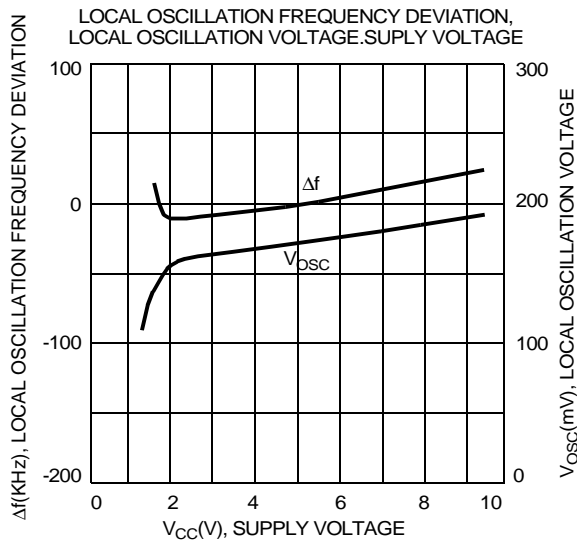

## APPLICATION INFORMATION

### RF AMP

The RF AMP is a common base type, so the operating frequency range is improved. The GND of the bypass capacitor (Pin 2) should be located closely at Pin 5 (GND). When using the bypass capacitor at  $V_{CC}$ -line of Pin 3. We can expect an improvement of the S/N ratio.

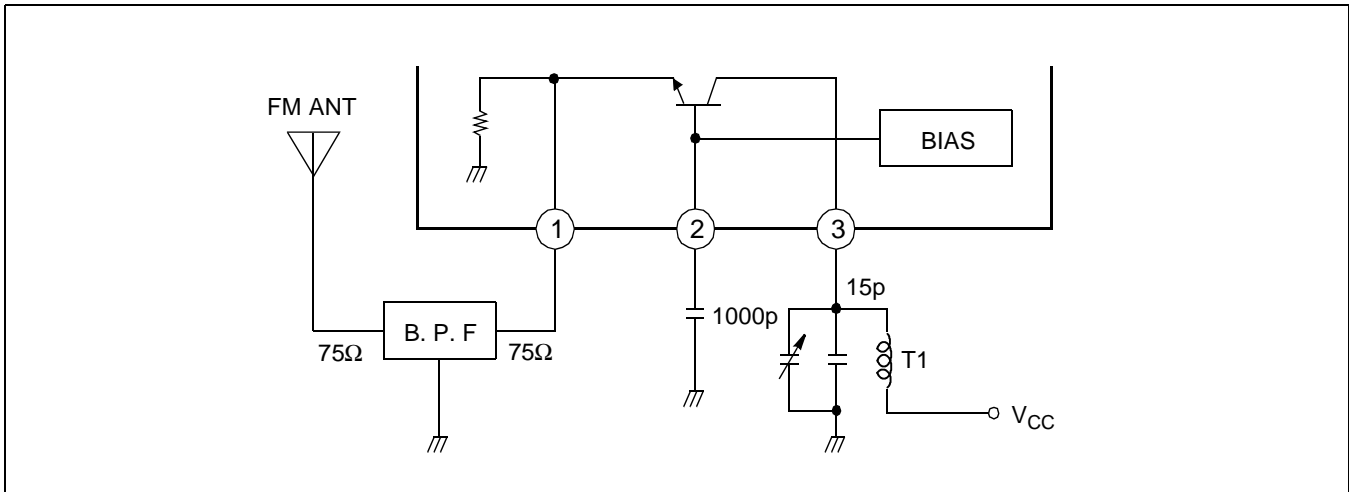

### MIXER

The mixer stage uses a double balanced type in order to protect the leakage of OSC, spurious radiation. Also, this is built into the limiter in order to improve the strong input characteristic.

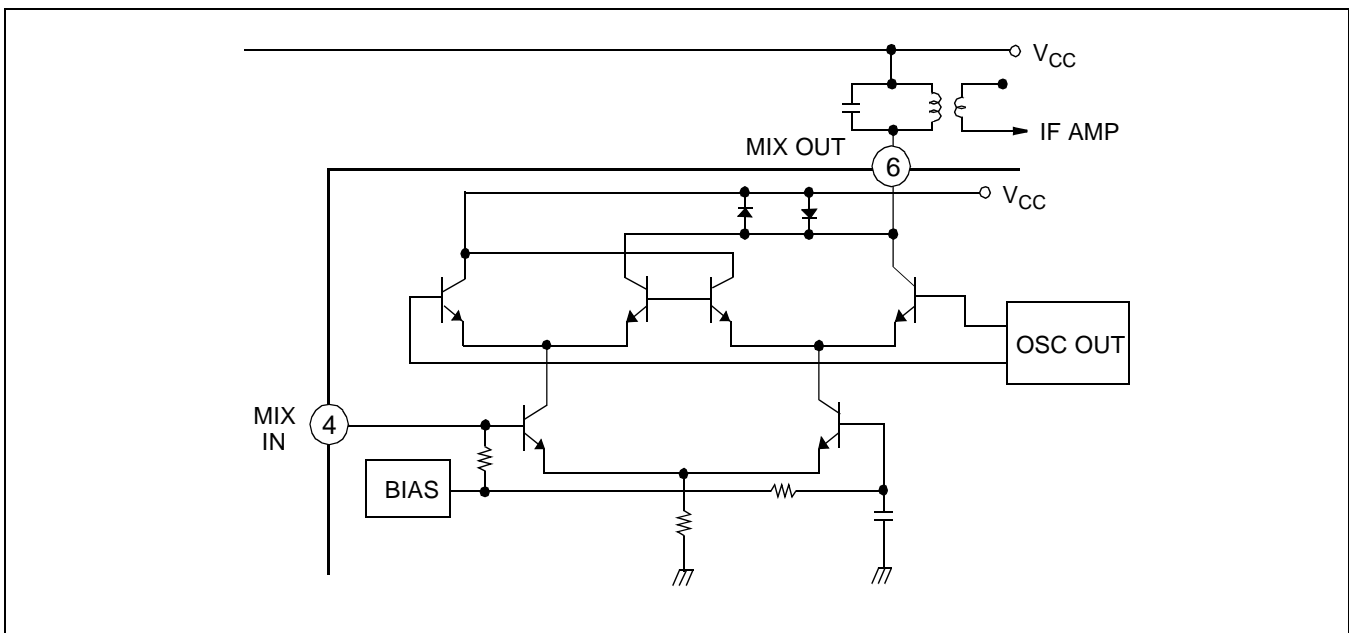



**LOCAL OSCILLATION**

The local oscillator uses a colpitts oscillator for stable oscillation at high frequency. This is built into the OSC buffer in order to stably operate the OSC frequency and OSC voltage at strong input.

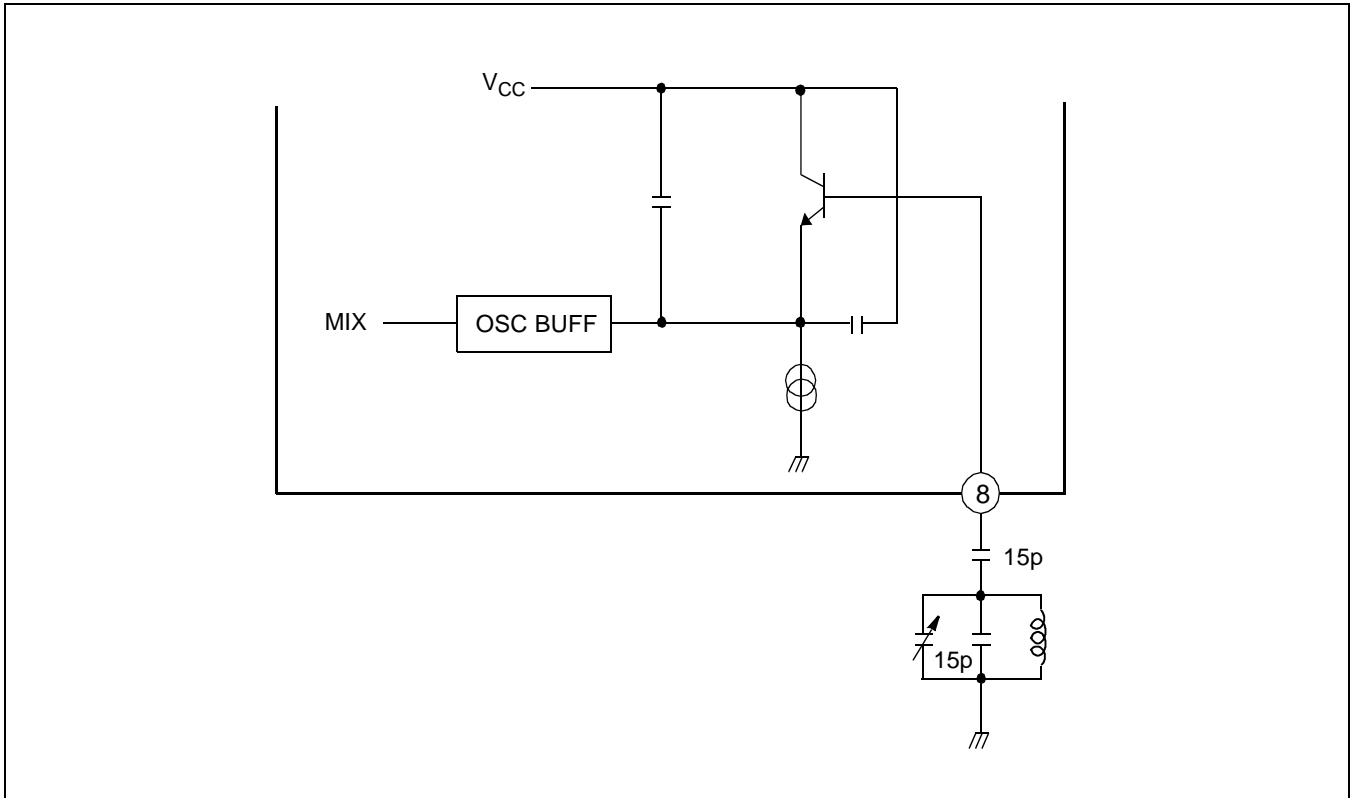

APPLICATION CIRCUIT

