

OVERVIEW

The SM8133B is a charge pump type white LED driver. It can drive 1 to 6 backlight white LED connected in parallel and 1 flash white LED. The output voltage circuit has a 3.0V LDO (Low Dropout Regulator), making the device ideal for camera-equipped cellular phones. The charge pump switches between $\times 1$ to $\times 1.5$ boost mode in response to LED drive current requirements to extend battery life to the maximum. The boost switching occurs in response to the drive current of all the connected LED and thus supports variations in LED forward-bias voltage drop (VF). Each LED drive current is controlled by a 7-channel LED drive current control circuit. The 6 backlight channels can be subdivided into 2 groups, with each group having independent dimming and lighting control. The backlight grouping, backlight LED drive current and ON/OFF control, flash LED drive current and ON/OFF control, and LDO output ON/OFF control are all set by 3-wire serial interface data input. Also, the RESETB pin can be connected to the microcontroller supply for a system-wide shutdown function.

FEATURES

- Noise reduction due to charge pump boost circuit
- Automatic charge pump switching to conserve power
- Drives 1 to 6 backlight white LED (30mA/ch at maximum setting)
- Drives a flash white LED (150mA at maximum setting)
- Backlight and flash white LED brightness adjustment
- Group settings for 2-group backlight lighting control
- 3-wire serial input interface for all setting and control
- 3.0V output LDO circuit built-in
- Shutdown function by RESETB pin
- Soft start circuit built-in
- Thermal protection circuit built-in
- Input voltage range
 - No-load current ($I_{OUT} = 0\text{mA}$): 2.7 to 4.6V
 - Load current ($I_{OUT} = 80\text{mA}$): 3.0 to 4.6V
 - Load current ($I_{OUT} = 200\text{mA}$): 3.3 to 4.6V
- Quiescent current
 - LDO only: 0.3mA (typ)
 - Not -switching ($\times 1.0$ mode): 0.5mA (typ)
 - Switching ($\times 1.5$ mode): 2.5mA (typ)
- Standby current: 0.01 μA (typ)
- Operating frequency: 750kHz (typ)
- Backlight LED current: 30mA/ch (typ)
- Flash LED current: 150mA (typ)
- All LED total maximum current: 200mA (typ)
- Backlight LED current matching ($I_{LED} = 30\text{mA}$): $\pm 3\%$
- Flash LED current accuracy ($I_{LED} = 150\text{mA}$): $\pm 5\%$
- LDO (Low Dropout Regulator) output voltage: $3.0\text{V} \pm 2\%$
- Packages: 20-pin QFN
WL-CSP (under development)

APPLICATIONS

- Cellular phone
- Digital still camera
- PDA
- Portable games

ORDERING INFORMATION

Device	Package
SM8133BB	20-pin QFN
SM8133BW	WL-CSP

PACKAGE DIMENSIONS

(Unit: mm)

QFN-20

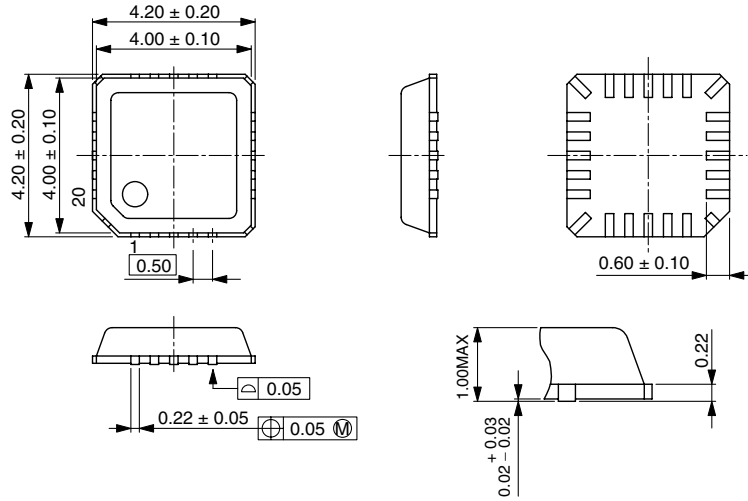

WL-CSP (under development)

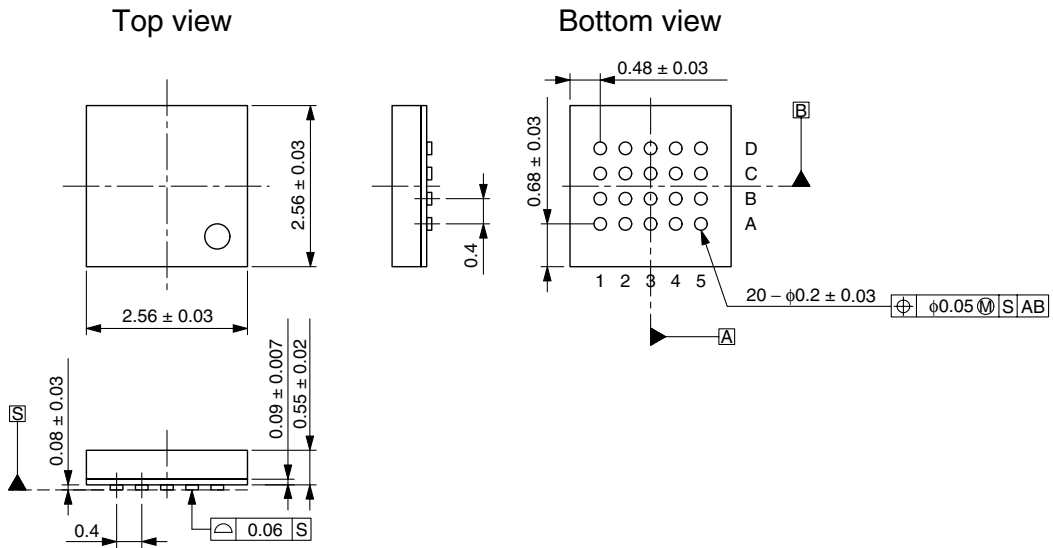

PINOUT

(Top view)

QFN-20

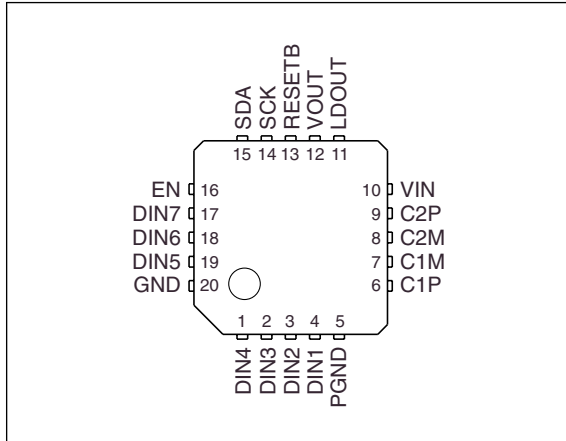

WL-CSP (under development)

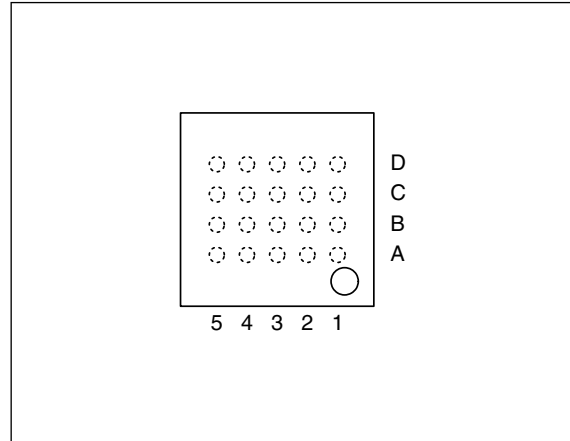

PIN DESCRIPTION

Number		Name	I/O	Description
QFN-20	WL-CSP			
1	D1	DIN4	O	LED drive current control output 4 (connect to ground when not used)
2	C1	DIN3	O	LED drive current control output 3 (connect to ground when not used)
3	B1	DIN2	O	LED drive current control output 2 (connect to ground when not used)
4	B2	DIN1	O	LED drive current control output 1 (connect to ground when not used)
5	A2	PGND	-	Charge pump ground connection
6	A1	C1P	-	Charge pump capacitor connection 1P
7	A3	C1M	-	Charge pump capacitor connection 1M
8	B3	C2M	-	Charge pump capacitor connection 2M
9	B4	C2P	-	Charge pump capacitor connection 2P
10	A4	VIN	-	Voltage supply
11	A5	LDOUT	O	LDO output
12	B5	VOUT	O	LED drive voltage output
13	C5	RESETB	I	Reset signal input (internal reset when RESETB is LOW)
14	C4	SCK	I	Serial data clock input
15	D5	SDA	I	Serial data input
16	D4	EN	I	Serial interface enable input
17	C3	DIN7	O	LED drive current control output 7 (connect to ground when not used)
18	D3	DIN6	O	LED drive current control output 6 (connect to ground when not used)
19	D2	DIN5	O	LED drive current control output 5 (connect to ground when not used)
20	C2	GND	-	Ground

BLOCK DIAGRAM

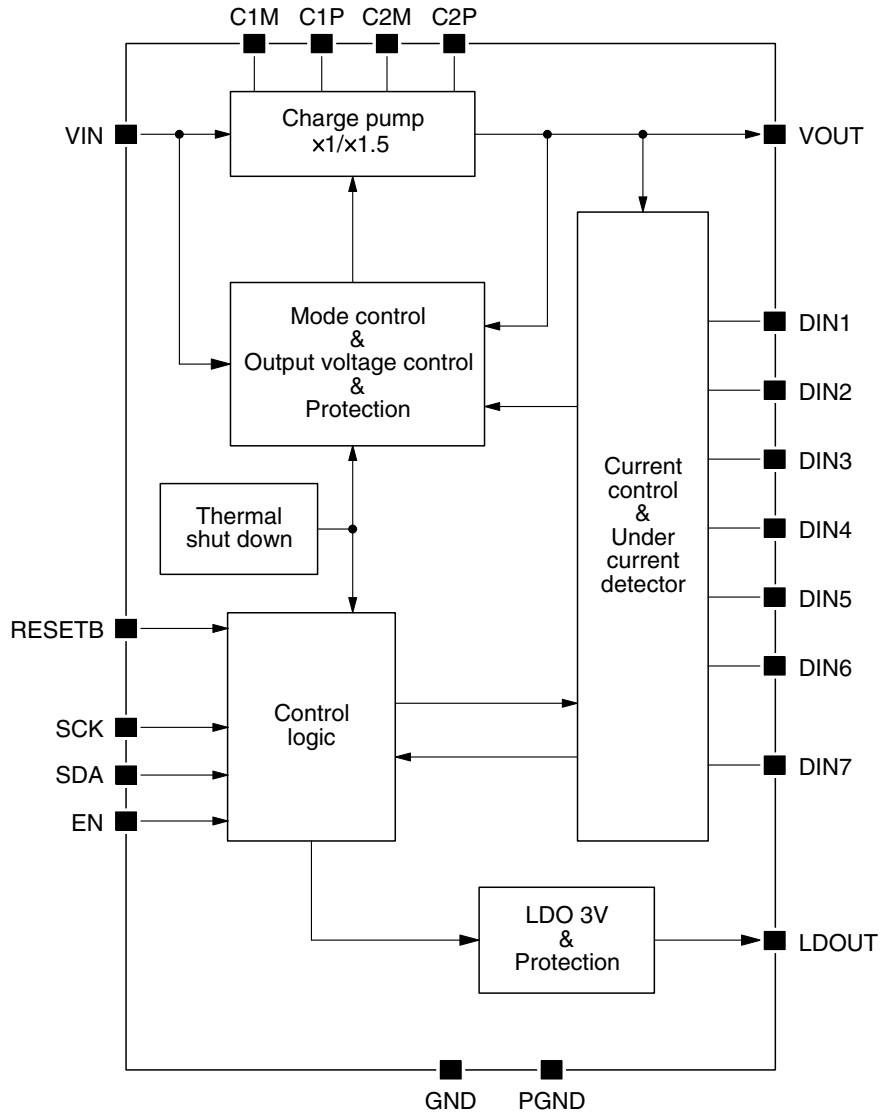

SPECIFICATIONS

Absolute Maximum Ratings

GND = PGND = 0V

Note. The device may suffer breakdown if any one of these parameter ratings is exceeded.

Parameter	Symbol	Rating	Unit
Supply voltage range	V_{IN}	-0.3 to 5.5	V
Input voltage range	V_{EN}, V_{SEL}	-0.3 to $V_{IN} + 0.3$	V
Output voltage range	$V_{DIN1 \text{ to } 7}$	-0.3 to $V_{IN} + 0.3$	V
	V_{OUT}	5.5	V
VOOUT output current	I_{OUT}	500	mA
LDO output current	I_{LDO}	200	mA
Power dissipation	P_D	$1429 (T_a = 25^\circ\text{C})^{*1}$	mW
Junction temperature	T_{JMAX}	+125	°C
Storage temperature range	T_{stg}	-55 to +125	°C

*1. When mounted on a $34 \times 40 \times 1.6$ mm glass epoxy board, the power dissipation is related to the operating temperature by the following equation.

- Maximum junction temperature: $T_{MAX} = 125^\circ\text{C}$
- Operating temperature: T_a [°C]
- Thermal resistance: $\theta_J = 70^\circ\text{C/W}$

$$P_D = \frac{(T_{MAX} - T_a)}{\theta_J}$$

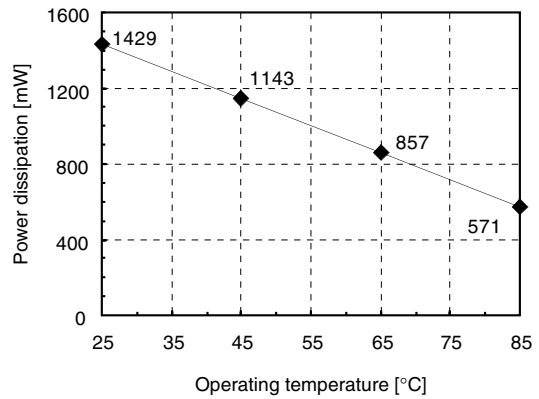

Recommended Operating Conditions

GND = PGND = 0V

Parameter	Pin	Symbol	Conditions	Rating			Unit
				min	typ	max	
Supply voltage range	VIN	V_{IN1}	$\times 1.0$ mode, $I_{OUT} = 0\text{mA}$	2.7	3.6	4.6	V
		V_{IN2}	$\times 1.5$ mode, $I_{OUT} = 80\text{mA}$	3.0	3.6	4.6	V
		V_{IN3}	$\times 1.5$ mode, $I_{OUT} = 200\text{mA}$	3.3	3.6	4.6	V
Input voltage range	EN, SCK, SDA, RESETB	V_{ES}	Each logic-level pin	0	-	V_{IN}	V
Ambient temperature range	-	T_a		-30	-	+85	°C

Electrical Characteristics

DC Characteristics

GND = PGND = 0V, $V_{IN} = 3.6V$, $T_a = 25^\circ C$ unless otherwise noted.

Parameter	Pin	Symbol	Condition	Rating			Unit
				min	typ	max	
Standby current	VIN	I_{STB}	Standby mode	–	0.01	1.00	μA
Quiescent current	VIN	I_{DD1}	LDO-only operating, no load	–	0.3	0.7	mA
		I_{DD2}	$\times 1.0$ mode, no load	–	0.5	1.0	mA
		I_{DD3}	$\times 1.5$ mode, no load	–	2.5	4.0	mA
Maximum output voltage	VOOUT	V_{OUT}	$\times 1.5$ mode VOOUT maximum voltage	4.8	5.0	5.2	V
Maximum output current	VOOUT	I_{OUT}	$\times 1.5$ mode	200	–	–	mA
Operating frequency	C1M	f_{OSC}	$\times 1.5$ mode switching frequency	650	750	850	kHz
Internal circuit power-ON reset time ^{*1}	EN	T_{POR}	Time from when power is applied until internal circuit reset	–	0.02	0.10	ms
Soft start time	DIN1 to 7	T_{SS}	Time between EN signal falling edge and LED turning ON	–	1.3	3.0	ms
LED drive pin leakage current	DIN1 to 7	$I_{LEAK1\ to\ 7}$	Standby mode, $V_{DIN1\ to\ 7} = 5.0V$	–	0.01	1.00	μA
LED drive current matching	DIN1 to 6	ΔI_{LED}	$\times 1.0$ mode, matching between channels with $I_{LED1\ to\ 6}$ maximum setting	–3.0	–	+3.0	%
LED maximum drive current 1	DIN1 to 6	$I_{LED1\ to\ 6}$	$\times 1.0$ mode, $I_{LED1\ to\ 6}$ maximum setting	27.0	30.0	33.0	mA
LED drive pin voltage 1	DIN1 to 6	$V_{DIN1\ to\ 6}$	$I_{LED1\ to\ 6}$ maximum setting	80	120	150	mV
LED maximum drive current 2	DIN7	I_{LED7}	$\times 1.5$ mode, I_{LED7} maximum setting	142.5	150.0	157.5	mA
LED drive pin voltage 2	DIN7	V_{DIN7}	I_{DIN7} maximum setting	225	300	375	mV
LDO output voltage	LDOUT	V_{LDO}	$V_{IN} = 3.6V$, $I_{LDO} = 100mA$	2.94	3.00	3.06	V
LDO maximum output current	LDOUT	I_{LDO}	$V_{IN} = 3.0V$, $V_{LDO} = 2.85V$	100	–	–	mA
LDO input stability	LDOUT	ΔV_{OUT1}	$3.3V \leq V_{IN} \leq 4.6V$, $I_{LDO} = 30mA$	–	–	1.0	%/V
LDO load stability	LDOUT	ΔV_{OUT2}	$V_{IN} = 3.6V$, $10\mu A \leq I_{LDO} \leq 80mA$	–	–	100	mV
LDO overcurrent protection circuit operating current	LDOUT	I_{OS}	$V_{IN} = 3.6V$	120	230	360	mA
Thermal protection circuit operating temperature ^{*1}	–	T_{SD}	Not in test mode	–	180	–	$^\circ C$
Thermal protection circuit hysteresis ^{*1}	–	T_{SDHYS}	Not in test mode	–	20	–	$^\circ C$
Logic-level input voltage	EN, SCK, SDA, RESETB	V_{IH}	HIGH-level input voltage range	1.8	–	–	V
		V_{IL}	LOW-level input voltage range	–	–	0.6	V
		V_{IHYS}	Hysteresis voltage width	–	0.3	0.5	V
Logic-level input current	EN, SCK, SDA, RESETB	I_{IL}	EN = SCK = SDA = RESETB = VIN	–	–	1.0	μA
		I_{IH}	EN = SCK = SDA = RESETB = GND	–1.0	–	–	μA

*1. Design guaranteed value

AC Characteristics

GND = 0V, $V_{IN} = 3.6V$, $T_a = 25^\circ C$ unless otherwise noted.

Parameter	Symbol	Condition	Rating			Unit
			min	typ	max	
SCK clock cycle	t_{SCK}		2000	–	DC	ns
SCK HIGH-level pulse width	t_{WH}		800	–	–	ns
SCK LOW-level pulse width	t_{WL}		800	–	–	ns
EN setup time	t_{CS}		1000	–	–	ns
EN hold time	t_{CH}		800	–	–	ns
EN recovery time	t_{CR}		1000	–	–	ns
Write data setup time	t_{DS}		600	–	–	ns
Write data hold time	t_{DH}		600	–	–	ns

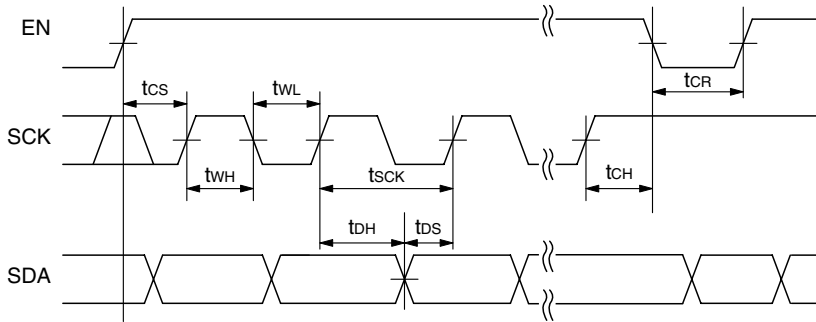

Data input timing diagram

V_{OUT} EFFICIENCY

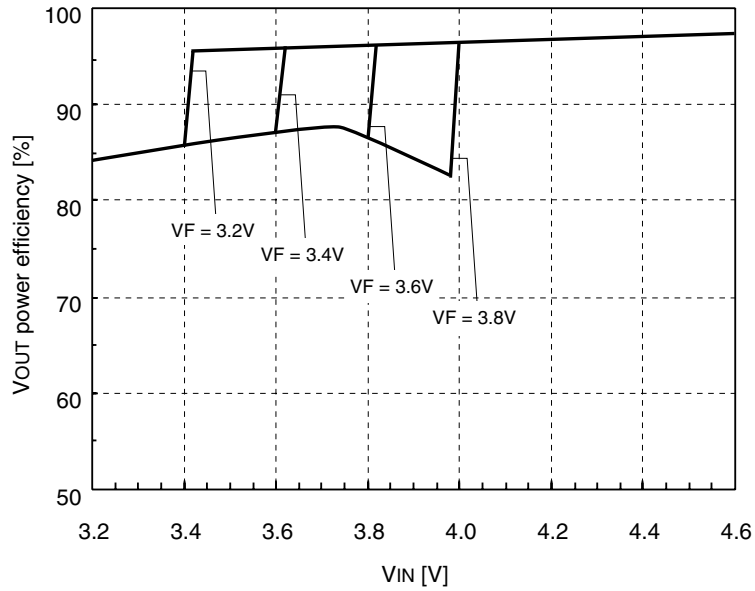

Efficiency of P_{IN} vs. P_{OUT}
 Backlight LED × 6pcs, I_{LED1 to 6} = 20mA,
 Flash LED × 1pc, I_{LED7} = 0mA,
 I_{OUT} = 120mA, I_{LDO} = 0mA

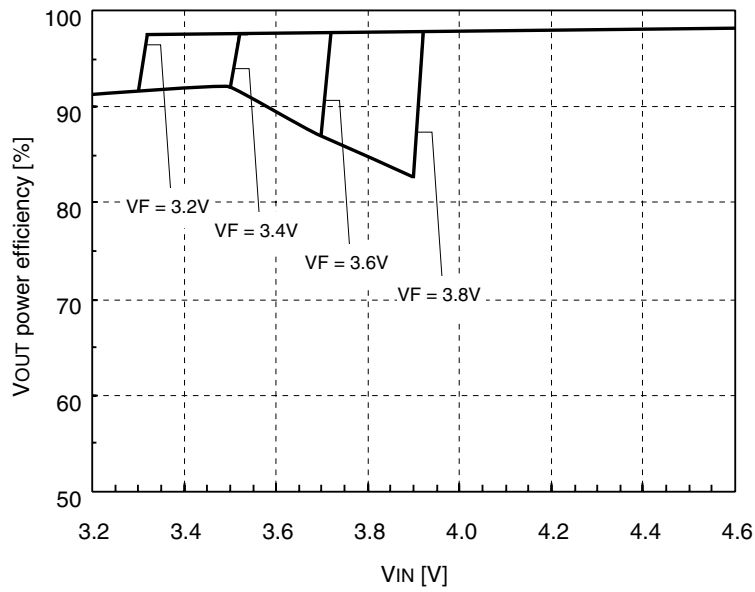

Efficiency of P_{IN} vs. P_{OUT}
 Backlight LED × 3pcs, I_{LED1 to 6} = 15mA,
 Flash LED × 1pc, I_{LED7} = 0mA,
 I_{OUT} = 45mA, I_{LDO} = 0mA

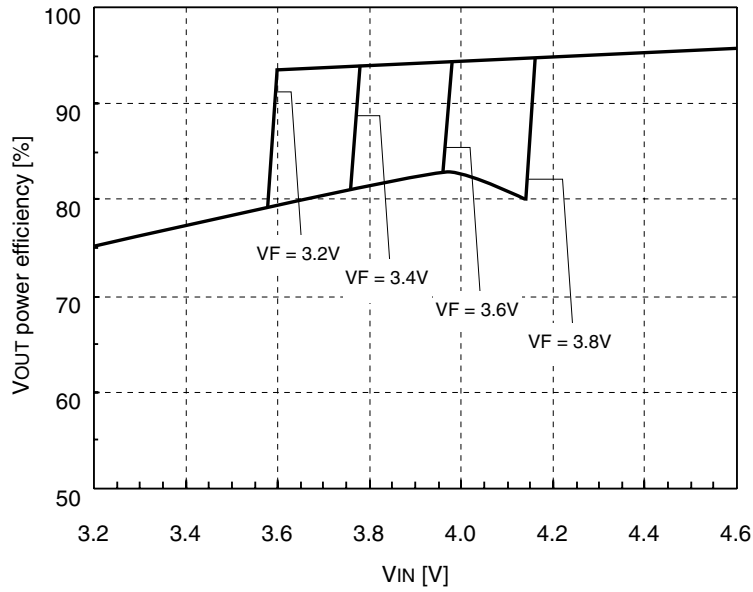

Efficiency of P_{IN} vs. P_{OUT}
 Backlight LED \times 6pcs, $I_{LED1\text{ to }6} = 20\text{mA}$,
 Flash LED \times 1pc, $I_{LED7} = 80\text{mA}$,
 $I_{OUT} = 200\text{mA}$, $I_{LDO} = 0\text{mA}$

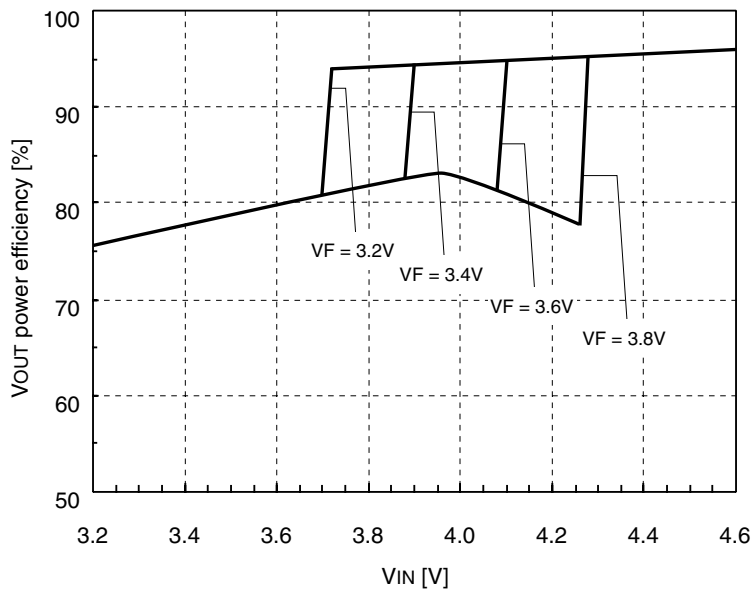

Efficiency of P_{IN} vs. P_{OUT}
 Backlight LED \times 3pcs, $I_{LED1\text{ to }6} = 15\text{mA}$,
 Flash LED \times 1pc, $I_{LED7} = 150\text{mA}$,
 $I_{OUT} = 195\text{mA}$, $I_{LDO} = 0\text{mA}$

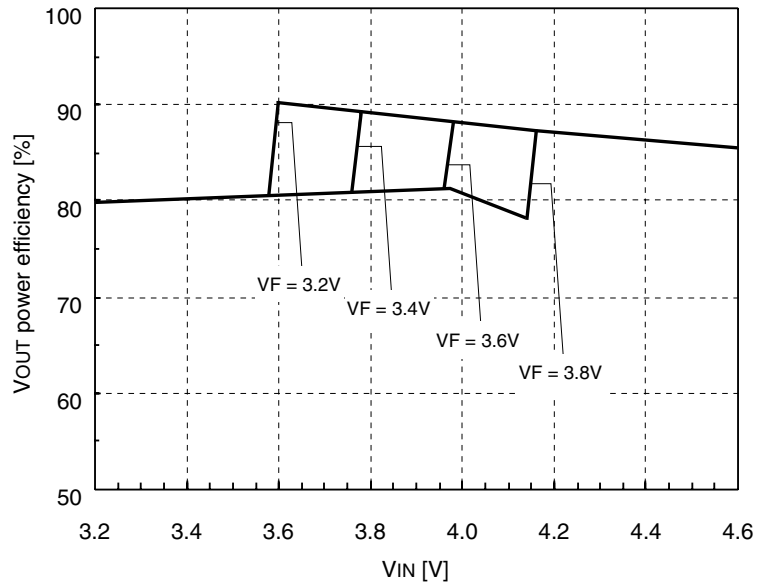

Efficiency of P_{IN} vs. P_{OUT}
 Backlight LED \times 6pcs, $I_{LED1\text{ to }6} = 20\text{mA}$,
 Flash LED \times 1pc, $I_{LED7} = 80\text{mA}$,
 $I_{OUT} = 200\text{mA}$, $I_{LDO} = 100\text{mA}$

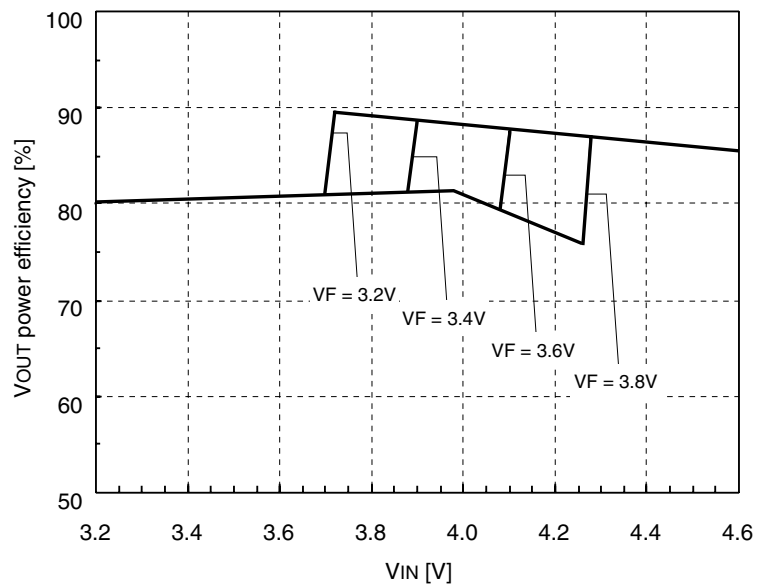

Efficiency of P_{IN} vs. P_{OUT}
 Backlight LED \times 3pcs, $I_{LED1\text{ to }6} = 15\text{mA}$,
 Flash LED \times 1pc, $I_{LED7} = 150\text{mA}$,
 $I_{OUT} = 195\text{mA}$, $I_{LDO} = 100\text{mA}$

FUNCTIONAL DESCRIPTION

Serial Interface

The SM8133B uses a 3-wire serial interface to control each setting. Input data on SDA is input MSB first in an 8 clock pulse cycle structure, with the first 4 cycles of data setting the mode and the next 4 the corresponding mode data. Data bits on SDA are read as received data on the rising edges of the SCK clock after EN goes HIGH. Only the leading 8 bits on SDA are read after EN goes HIGH and all subsequent input data bits are ignored, but the received data is reflected in SM8133B operation with timing almost simultaneous with the EN falling edge. Conversely, if less than 8 bits are input on SDA, the data is ignored to prevent incorrect operation. All registers are write-only, and their status cannot be read. After power is applied, an internal power-ON reset circuit initializes all registers to logic level LOW in standby mode. However, the possibility exists that there may be insufficient reset time, depending on the VIN input voltage rise time and fall time, so reset mode (0H or EH) should be expressly invoked after power is applied. There is no restriction in the input sequence when setting parameters. However, since the parameters are set in the same order as the data input sequence and the time taken from LED ON/OFF data input to LED dimming data input can exceed the soft start time, it is highly advisable to enter the LED dimming data first. The charge pump circuit, that supplies the LED drive voltage, starts whenever any parameter in address 5H (LED ON register) is set to 1, with the LED drive voltage output on VOUT. Conversely, when all parameters in address 5H are set to 0, all other parameter data settings input after reset are retained in standby mode. The serial interface pins EN, SDA, CSK, and RESETB are CMOS inputs, thus the input voltage on VIN must be a logic-level voltage and should not be left open circuit (floating).

Control Data

Mode selection data				Setting data			
M1	M2	M3	M4	D1	D2	D3	D4
MSB	Data 1	Data 2	Data 3	Data 4	Data 5	Data 6	LSB

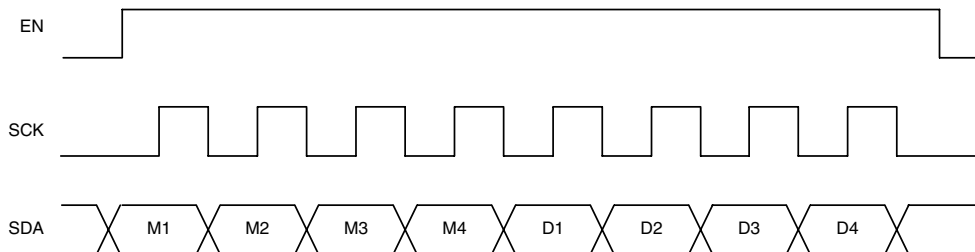

Control data input sequence

■ Mode selection

Mode data	0H	1H	2H	3H	4H
Mode	Reset	Grouping	A group dimming	B group dimming	DIN7 dimming
M1-M2-M3-M4	L-L-L-L	L-L-L-H	L-L-H-L	L-L-H-H	L-H-L-L

Mode data	5H	6H	EH	FH	Other
Mode	LED ON	System settings	Reset	Serial input test	NPC test
M1-M2-M3-M4	L-H-L-H	L-H-H-L	H-H-H-L	H-H-H-H	—

Mode data “0H”: Reset register**Mode data “EH”: Reset register**

Setting data	D1	D2	D3	D4
High	All system data reset			
Low	System standby			

Reset mode is selected if EN goes LOW 4 clock cycles after 0H or EH mode select data is input, regardless of when power is applied or the parameter set data bits. When reset mode is selected, all data input previously is reset, thus grouping, dimming, and control data must be reentered.

Mode data “1H”: Grouping register

Setting data	D1	D2	D3	D4
High	LED3 = B group	LED4 = B group	LED5 = B group	LED6 = B group
Low	LED3 = A group	LED4 = A group	LED5 = A group	LED6 = A group

LED1 and LED2 are always assigned to A group. When a setting data bit is LOW, A group is selected. When HIGH, B group is selected.

Mode data “2H”: A group dimming register**Mode data “3H”: B group dimming register****Mode data “4H”: DIN7 dimming register**

Setting data	D1	D2	D3	D4	Selected dimming value
0H	Low	Low	Low	Low	0/15
1H	Low	Low	Low	High	1/15
2H	Low	Low	High	Low	2/15
3H	Low	Low	High	High	3/15
4H	Low	High	Low	Low	4/15
5H	Low	High	Low	High	5/15
6H	Low	High	High	Low	6/15
7H	Low	High	High	High	7/15
8H	High	Low	Low	Low	8/15
9H	High	Low	Low	High	9/15
AH	High	Low	High	Low	10/15
BH	High	Low	High	High	11/15
CH	High	High	Low	Low	12/15
DH	High	High	Low	High	13/15
EH	High	High	High	Low	14/15
FH	High	High	High	High	15/15

D1 to D4 setting data bits control the each group LED current in 15 steps. See “LED drive current”.

Mode data “5H”: LED ON register

Setting data	D1	D2	D3	D4
High	A group ON	B group ON	DIN7 ON	LDO ON
Low	A group OFF	B group OFF	DIN7 OFF	LDO OFF

This register controls the A group, B group, DIN7, and LDO ON/OFF state. Each state is ON when the corresponding bit is HIGH, and OFF when LOW. Each circuit starts when the corresponding bit in address 5H is set HIGH, transferring from standby mode. It is recommended that these 4 data settings be held LOW when possible to control current consumption.

Mode data “6H”: System register

Setting data	D1	D2	D3	D4
High	A group maximum current = 15mA	B group maximum current = 15mA	DIN7 maximum current = 75mA	–
Low	A group maximum current = 30mA	B group maximum current = 30mA	DIN7 maximum current = 150mA	–

Note. Target values only. Current rating accuracy is not guaranteed.

This register sets the maximum current drive for each group. For A and B group, LOW sets 30mA as the maximum, HIGH sets 15mA. For DIN7, LOW sets 150mA, HIGH sets 75mA as the maximum.

LED drive current (Hexadecimal)

Dimming register value	A group		B group		DIN7		Unit
	A group max. current = 0	A group max. current = 1	B group max. current = 0	B group max. current = 1	DIN7 max. current = 0	DIN7 max. current = 1	
0H	0	0	0	0	0	0	mA
1H	2	1	2	1	10	5	mA
2H	4	2	4	2	20	10	mA
3H	6	3	6	3	30	15	mA
4H	8	4	8	4	40	20	mA
5H	10	5	10	5	50	25	mA
6H	12	6	12	6	60	30	mA
7H	14	7	14	7	70	35	mA
8H	16	8	16	8	80	40	mA
9H	18	9	18	9	90	45	mA
AH	20	10	20	10	100	50	mA
BH	22	11	22	11	110	55	mA
CH	24	12	24	12	120	60	mA
DH	26	13	26	13	130	65	mA
EH	28	14	28	14	140	70	mA
FH	30	15	30	15	150	75	mA

Note. “H”: Hexadecimal

Note. Target values only. Current rating accuracy is not guaranteed.

LDO (Low Dropout Voltage Regulator)

Operation is controlled using the LDO register (LSB in address “5H”). When the LDO register is set to 1, a regulated stable voltage is output from LDOUT. If the overcurrent protection circuit connected to LDOUT detects a continuous overcurrent condition for approximately 200 μ s, the LDO output stops and then restarts after a delay of approximately 1.4 seconds. At this point, if an overcurrent condition is detected again, the LDO output stops. If the overcurrent condition is detected a total of 12 successive times (approximately 16.8 seconds), the LDO load is deemed to be abnormal and the LDO output stops completely. The abnormal load condition is released only by selecting reset mode operation.

THERMAL SHUTDOWN CIRCUIT (Overheating Protection)

The thermal shutdown circuit operates whenever the IC temperature exceeds approximately 180°C for whatever reason. VOUT output recommences when the IC temperature falls below approximately 160°C.

RESETB INPUT (Internal Circuit Reset Signal)

If the microcontroller, which drives the serial data inputs, stops, the SM8133B logic-level signal inputs are left floating and the SM8133B will most likely not transfer to standby mode normally. However, the RESETB pin can be connected to the microcontroller supply pin, so that the SM8133B is reset automatically whenever the voltage on RESETB drops. A pull-down resistor should be connected between RESETB and GND to avoid a floating RESETB input with voltage applied to the VIN pin.

STARTUP SEQUENCE

After power is applied to the SM8133B or when a reset input occurs (active-LOW input on RESETB or reset register mode setting), the internal power-ON reset circuit initializes all registers to their default value of 0. Consequently, all required data for LED drive operation must be input using the serial interface. The registers can be addressed in arbitrary sequence. Note that the registers are set in the same sequence as they are addressed.

Example 1. Set LED1 to LED6 to 30mA drive without group setting

Set EN HIGH, input “2FH” using the serial interface, set EN LOW (A group current setting 30mA), set EN HIGH, input “58H”, set EN LOW (A group ON), LED1 to LED6 turn ON after the soft start ends.

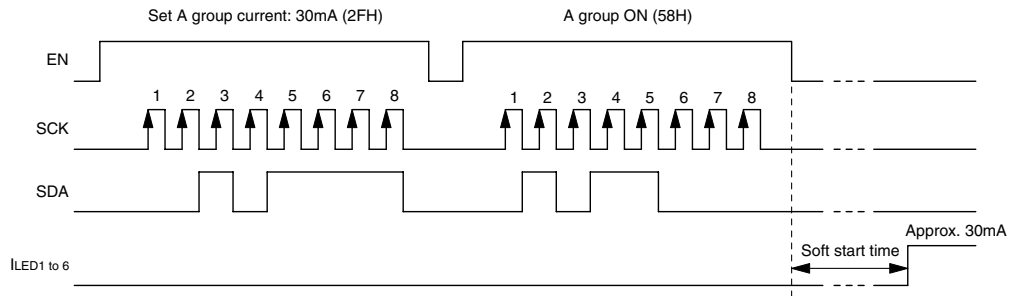

Example 1 input waveform

Example 2. Set LED1 to LED4 to A group, LED5 and LED6 to B group, and individual group brightness

Input “13H” using the serial interface (group setting), input “25H” (A group current setting 10mA), input “3AH” (B group current setting 20mA), input “5CH” (A and B groups ON) on successive EN cycles. LED1 to LED6 turn ON after the soft start ends.

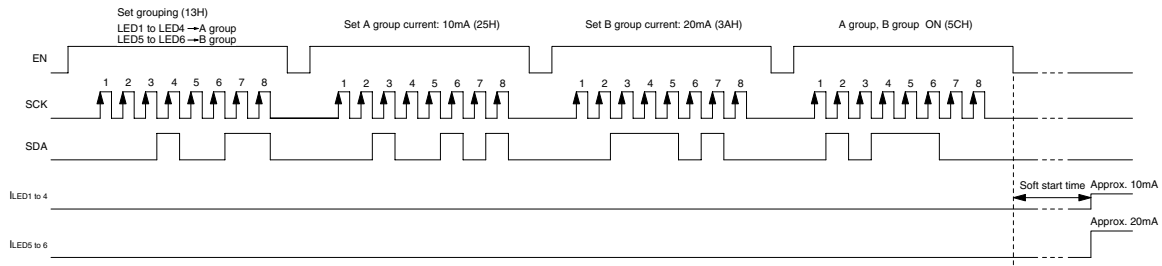

Example 2 input waveform

Example 3. Set LED1 to LED6 to 30mA drive, temporarily turn OFF, turn ON again, and reset using RESETB input without group setting

Input “2FH”(A group current setting 30mA) and “58H” (A group ON) from the serial interface. LED1 to LED6 turn ON after the soft start ends. While the LEDs are ON, input “50H” (A group OFF) to turn the LEDs OFF and transfer the SM8133B to standby mode. The internal register setting “2FH” (A group current setting 30mA) data is retained during standby mode, so you need to input “58H” (A group ON) only to turn the LEDs ON again. At this point, the charge pump soft start circuit operates again, taking a soft start time of approximately 1.3ms from when the data is input to when the LEDs turn ON. If RESETB is connected to the microcontroller power supply and the supply goes LOW, the SM8133B is reset, the LEDs turn OFF, and operation transfers to standby mode.

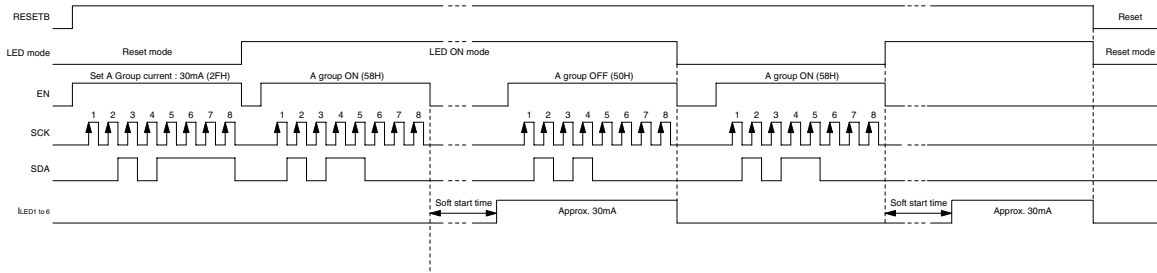

Example 3 input waveform

TYPICAL APPLICATION CIRCUIT

If the RESETB input is connected to the microcontroller power supply, the SM8133B is reset when microcontroller power supply stops, and operation transfers to standby mode. In circuits where the SM8133B logic-level inputs would become open circuit (floating) when the microcontroller supply stops, pull-down resistors should be connected to each logic-level signal input.

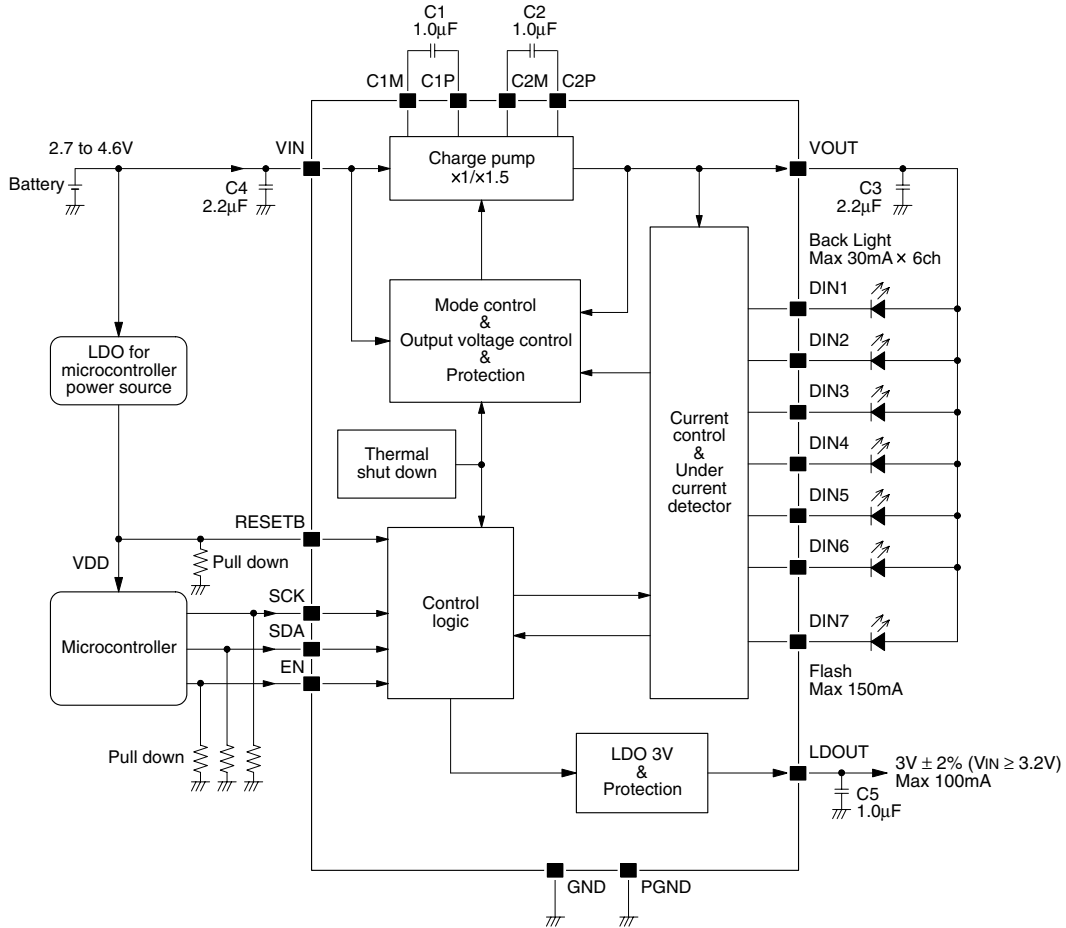

Note. If the driving LEDs are less than 7 pcs, the unused DIN pins should be connected to GND.

PERIPHERAL PARTS

About the External Capacitors

The best capacitors for use with the SM8133B are multi-layer ceramic capacitors. When selecting a multi-layer ceramic capacitor, only X5R and X7R dielectric types are strongly recommended, since the loss of capacitance in various conditions is less than other types such as Z5U and Y5V. The much loss of capacitance in various conditions may cause the output voltage unstable.

Table. The EIA three digit "TC" code

Lower temperature limit	High temperature limit	Maximum allowable capacitance change from + 25°C (0V DC)
X = -55°C	5 = +85°C	F = ± 7.5%
Y = -30°C	6 = +105°C	P = ± 10%
Z = +10°C	7 = +125°C	R = ± 15%
	8 = +150°C	S = ± 22%
		T = +22%/-33%
		U = +22%/-56%
		V = +22%/-82%

For example : X5R

About the Input Capacitor "C4"

The parts layout of PCB may merely cause the "V_{OUT}" output voltage unstable. In this case, increasing the "C4" input capacitance value or adding another capacitor on the VIN input line is effective to solve the unstable output voltage.

QFN-20 Package

Package corner metals are not IC I/O pins. Don't connect any lines to these corner metals.

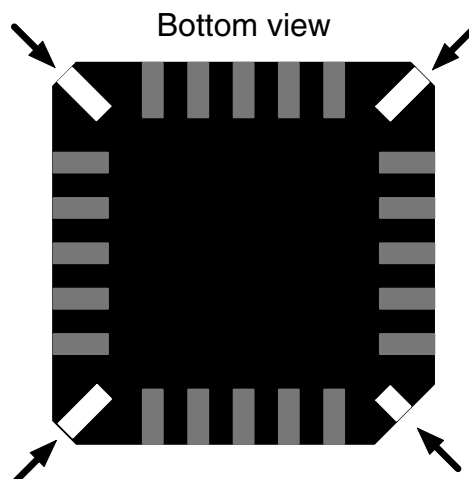

FOOTPRINT PATTERN

The optimum footprint varies depending on the board material, soldering paste, soldering method, and equipment accuracy, all of which need to be considered to meet design specifications.

(Unit: mm)

Package	HE	HD	e	b3	I1	I2
QFN-20	4.2	4.2	0.5	0.30 ± 0.05	0.20 ± 0.05	0.70 ± 0.05

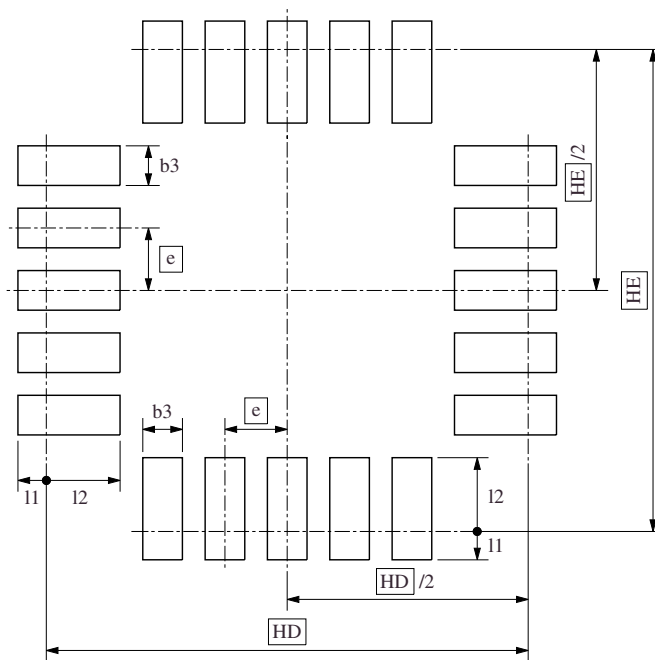

Please pay your attention to the following points at time of using the products shown in this document.

The products shown in this document (hereinafter "Products") are not intended to be used for the apparatus that exerts harmful influence on human lives due to the defects, failure or malfunction of the Products. Customers are requested to obtain prior written agreement for such use from NIPPON PRECISION CIRCUITS INC. (hereinafter "NPC"). Customers shall be solely responsible for, and indemnify and hold NPC free and harmless from, any and all claims, damages, losses, expenses or lawsuits, due to such use without such agreement. NPC reserves the right to change the specifications of the Products in order to improve the characteristic or reliability thereof. NPC makes no claim or warranty that the contents described in this document dose not infringe any intellectual property right or other similar right owned by third parties. Therefore, NPC shall not be responsible for such problems, even if the use is in accordance with the descriptions provided in this document. Any descriptions including applications, circuits, and the parameters of the Products in this document are for reference to use the Products, and shall not be guaranteed free from defect, inapplicability to the design for the mass-production products without further testing or modification. Customers are requested not to export or re-export, directly or indirectly, the Products to any country or any entity not in compliance with or in violation of the national export administration laws, treaties, orders and regulations. Customers are requested appropriately take steps to obtain required permissions or approvals from appropriate government agencies.

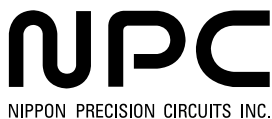

NIPPON PRECISION CIRCUITS INC.

15-6, Nihombashi-kabutocho, Chuo-ku,
Tokyo 103-0026, Japan

Telephone: +81-3-6667-6601

Facsimile: +81-3-6667-6611

<http://www.npc.co.jp/>

Email: sales@npc.co.jp

NC0503AE 2005.06