



Data Book

AU6386

**USB2.0 Flash Disk Controller
Technical Reference Manual**

Product Specification

Official Release

Revision 1.04

Public

Oct 2005



Data Sheet Status

Objective specification	This data sheet contains target or goal specifications for product development.
Preliminary specification	This data sheet contains preliminary data; supplementary data may be published later.
Product specification	This data sheet contains final product specifications.

Revision History

Date	Revision	Description
Apr 2005	1.02W/A31, A32	Removed the schematics. Please contact our sales if you need it.
Oct 2005	1.04W	To modify "5.2 Recommended Operating Conditions"



Copyright Notice

Copyright 1997 - 2005
Alcor Micro Corp.
All Rights Reserved.

Trademark Acknowledgements

The company and product names mentioned in this document may be the trademarks or registered trademarks of their manufacturers.

Disclaimer

Alcor Micro Corp. reserves the right to change this product without prior notice.
Alcor Micro Corp. makes no warranty for the use of its products and bears no responsibility for any error that appear in this document. Specifications are subject to change without prior notice.

Contact Information:

Web site: <http://www.alcormicro.com/>

Taiwan

Alcor Micro Corp.
4F, No 200 Kang Chien Rd., Nei Hu,
Taipei, Taiwan, R.O.C.
Phone: 886-2-8751-1984
Fax: 886-2-2659-7723

Santa Clara Office

2901 Tasman Drive, Suite 206
Santa Clara, CA 95054
USA
Phone: (408) 845-9300
Fax: (408) 845-9086

Los Angeles Office

9070 Rancho Park Court
Rancho Cucamonga, CA.91730
USA
Phone: (909) 483-9900
Fax: (909) 944-0464



Table of Contents

1	<u>Introduction</u>	6
	<u>1.1 Description</u>	6
	<u>1.2 Features</u>	6
2	<u>Application Block Diagram</u>	7
3	<u>Pin Assignment</u>	8
4	<u>System Architecture and Reference Design</u>	11
	<u>4.1 AU6386 Block Diagram</u>	11
5	<u>Electrical Characteristics</u>	12
	<u>5.1 Absolute Maximum Ratings</u>	12
	<u>5.2 Recommended Operating Conditions</u>	12
	<u>5.3 General DC Characteristics</u>	12
	<u>5.4 DC Electrical Characteristics for 5 volts operation</u>	13
	<u>5.5 USB Transceiver Characteristics</u>	13
6	<u>Mechanical Information</u>	17
7	<u>Abbreviations</u>	18



List of Figures

2.1	Block Diagram	7
3.1	Pin Assignment Diagram	8
4.1	AU6386 Block diagram	11
6.1	Mechanical Information Diagram	17

List of Tables

3.1	Pin Descriptions	9
5.1	Absolute Maximum Ratings	12
5.2	Recommended Operating Conditions	12
5.3	General DC Characteristics	12
5.4	DC Electrical Characteristics of 3.3V I/O Cells	13
5.5	Electrical characteristics	13
5.6	Static characteristic : Digital Pin	14
5.7	Static characteristic : Analog I/O pins (DP/DM)	14
5.8	Dynamic characteristic : Analog I/O pins (DP/DM)	15



1.0. Introduction

1.1. Description

AU6386 is a highly integrated single chip for USB2.0 flash disk controller. It can be used as a removable storage disk in enormous data exchange application between USB enabled PC and NAND type flash memory. Not only it can be used as a removable storage disk in Windows PC, Apple Macintosh, Notebook and Linux/Unix workstation, it also can be configured as bootable disk for system reparation.

AU6386 is an outstanding USB storage device controller; it provides a new innovative feature – Autorun. It will automatically execute the customized images file to illustrate company logo or branding image. Besides, It will be able to allow OEM or manufacturer to change its private label icon and modify arbitrarily label name in order to demonstrate its unique design and make end-user easily to distinguish a removable storage disk from other disks in the computer.

Alcor Micro provides a smart application – iRun handy tool for AU6386 to manage USB storage device. The iRun supplies the features as show device status instantly, disk partition management, password protection, software write protection. These unique features give hardware device maker and software vendor tremendous opportunity to develop user-friendly appliance and application.

1.2. Features

- Support USB v2.0 specification and USB Device Class Definition for Mass Storage, Bulk-Transport v1.0
- Work with default driver from Windows ME, Windows 2000, Windows XP, Mac 9.2, Mac OS X and vendor driver from Alcor for Windows 98S
- Multiple FIFO implementation for concurrent bus operation
- 48-pin package supports up to 4 pieces of single die NAND Flash memory chip.
- LED for bus activity monitoring
- Runs at 30MHz, built-in 480 MHz PLL
- Built-in 3.3V to 2.5V regulator
- Built-in power on reset circuit
- Both support hardware and software write protection
- Support AutoRun feature.
 - AutoRun feature can be supported on Windows ME, Windows 2000, Windows XP and Windows 98 system.
- Support smart application – iRun handy tool
 - Support password protection for access security
 - Support partition and lock disk function.
 - Support software write protection function

2.0. Application Block Diagram

Following is the application diagram of a typical flash disk product with AU6386. By connecting the flash disk to a desktop or notebook PC through USB bus, AU6386 is implemented as a bus-powered, high speed USB disk, which can be used as a bridge for data transfer between Desktop PC and Notebook PC.

2.1 Block Diagram

Figure 2.1 Block Diagram

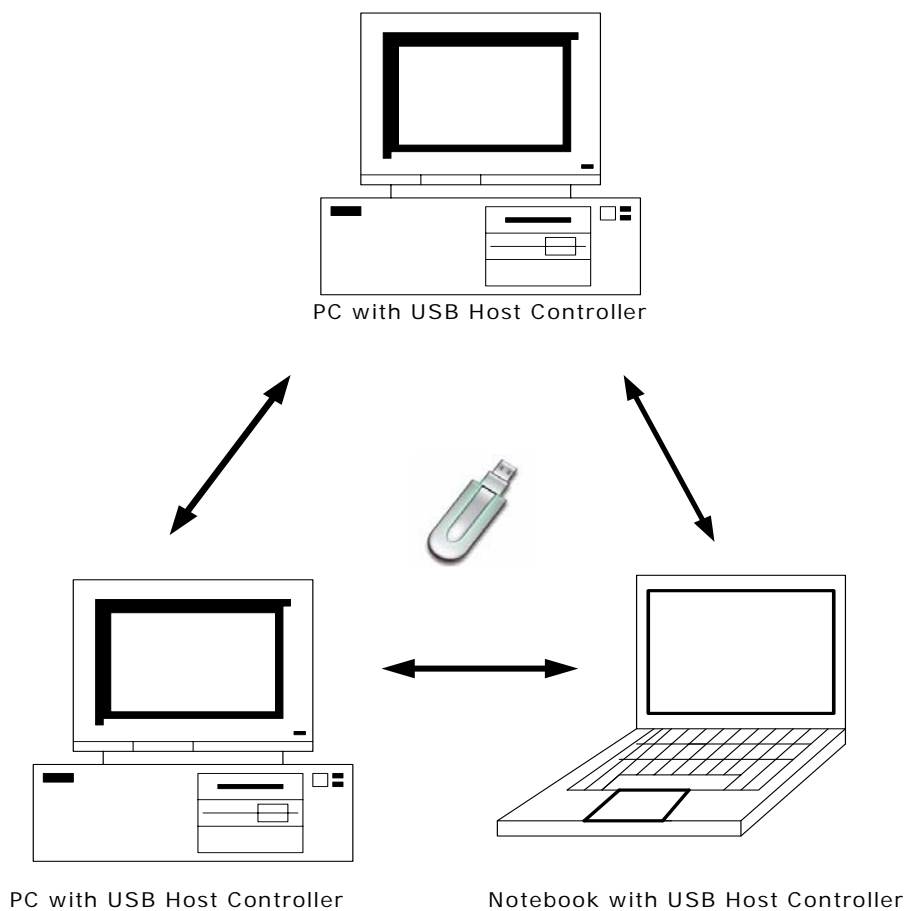

3.0. Pin Assignment

The AU6386 is packed in 48pin-LQFP-form factor. The following figure shows signal name for each pin and the table in the following page describes each pin in detail

Figure 3.1 Pin Assignment Diagram

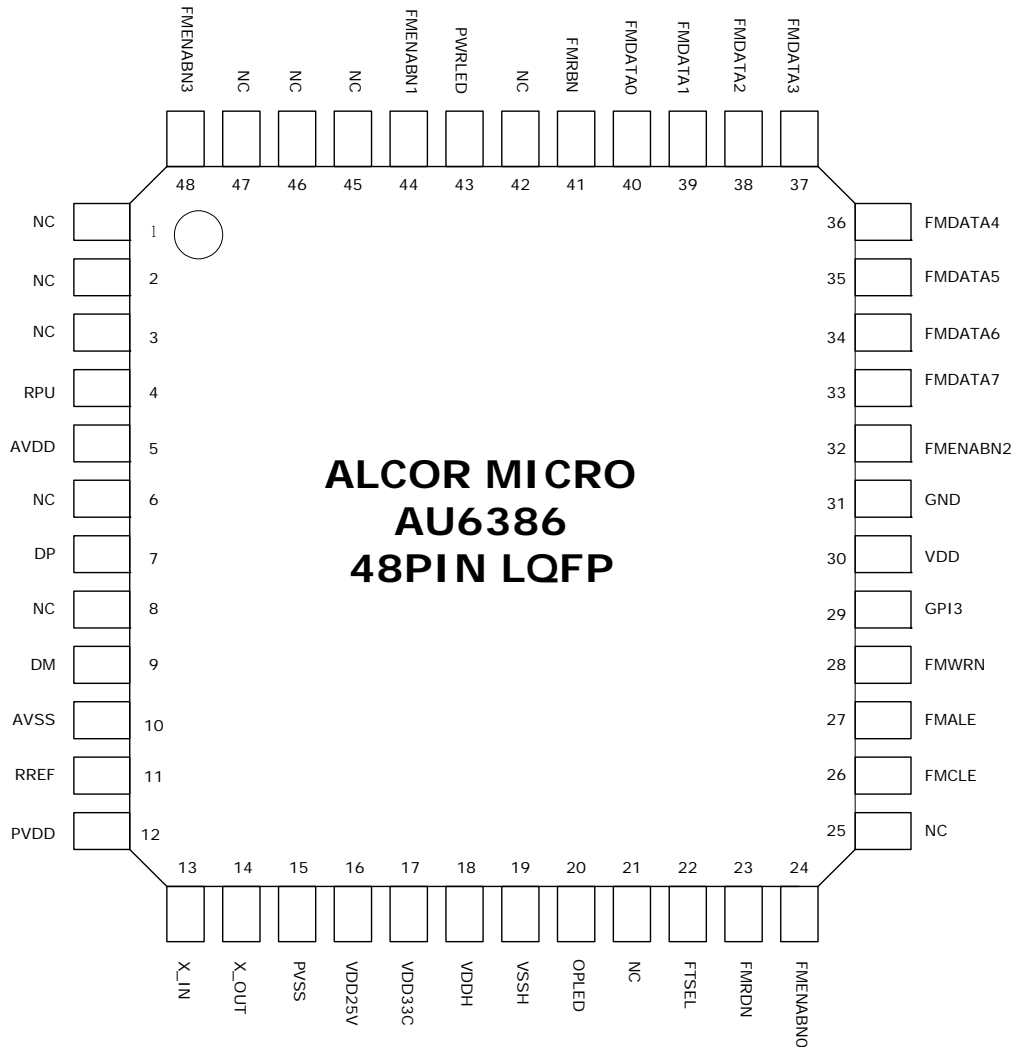



Table 3.1 Pin Descriptions

Pin #	Pin Name	I/O	Description
1	NC		
2	NC		
3	NC		
4	RPU	I	Connected with an 1.5k pull up resistor to 3.3V VDD
5	AVDD	I	3.3V Power Supply Input
6	NC		
7	DP	I/O	DP
8	NC		
9	DM	I/O	DM
10	AVSS	GND	Analog Ground
11	RREF	I	Connected to 1k resistor to analog ground
12	PVDD	I	3.3V Power Supply Input for Pad
13	X_IN	I	12 MHz crystal input.
14	X_OUT	O	12 MHz crystal output.
15	PVSS	GND	Pad Ground
16	VDD25V	O	2.5V voltage out for core
17	VDD33C	O	3.3V voltage out for flash
18	VDDH	I	3.3V Power Supply for IO
19	VSSH	GND	IO Ground
20	OPLED	O	LED for bus activity monitoring
21	NC	O	
22	FTSEL	I	Pull low for supporting MLC flash
23	FMRDN	O	FLASH MEMORY Read Enable
24	FMENABNO	O	Flash Memory #0 Enable
25	NC		
26	FMCLE	O	Flash Memory Command Latch Enable
27	FMALE	O	Flash Memory Address Latch Enable
28	FMWRN	O	Flash Memory Write Enable
29	GPI3	I	Hardware Write Protect ("0": Hardware Write Protect; "1": Normal)
30	VDD	I	Core Power 2.5V



Pin #	Pin Name	I/O	Description
31	GND	GND	GND
32	FMENABN2	O	Flash Memory #2 Enable
33	FMDATA7	I/O	Flash Memory Data [7]
34	FMDATA6	I/O	Flash Memory Data [6]
35	FMDATA5	I/O	Flash Memory Data [5]
36	FMDATA4	I/O	Flash Memory Data [4]
37	FMDATA3	I/O	Flash Memory Data [3]
38	FMDATA2	I/O	Flash Memory Data [2]
39	FMDATA1	I/O	Flash Memory Data [1]
40	FMDATA0	I/O	Flash Memory Data [0]
41	FMRBN	I	Flash Memory Ready and Busy Signal
42	NC		
43	PWRLED	O	LED for device power, Off when in suspend mode
44	FMENABN1	O	Flash Memory #1 Enable
45	NC		
46	NC		
47	NC		
48	FMENABN3	O	Flash Memory #3 Enable

4.0. System Architecture and Reference Design

4.1. Block Diagram

Figure 4.1 AU6386 Block Diagram

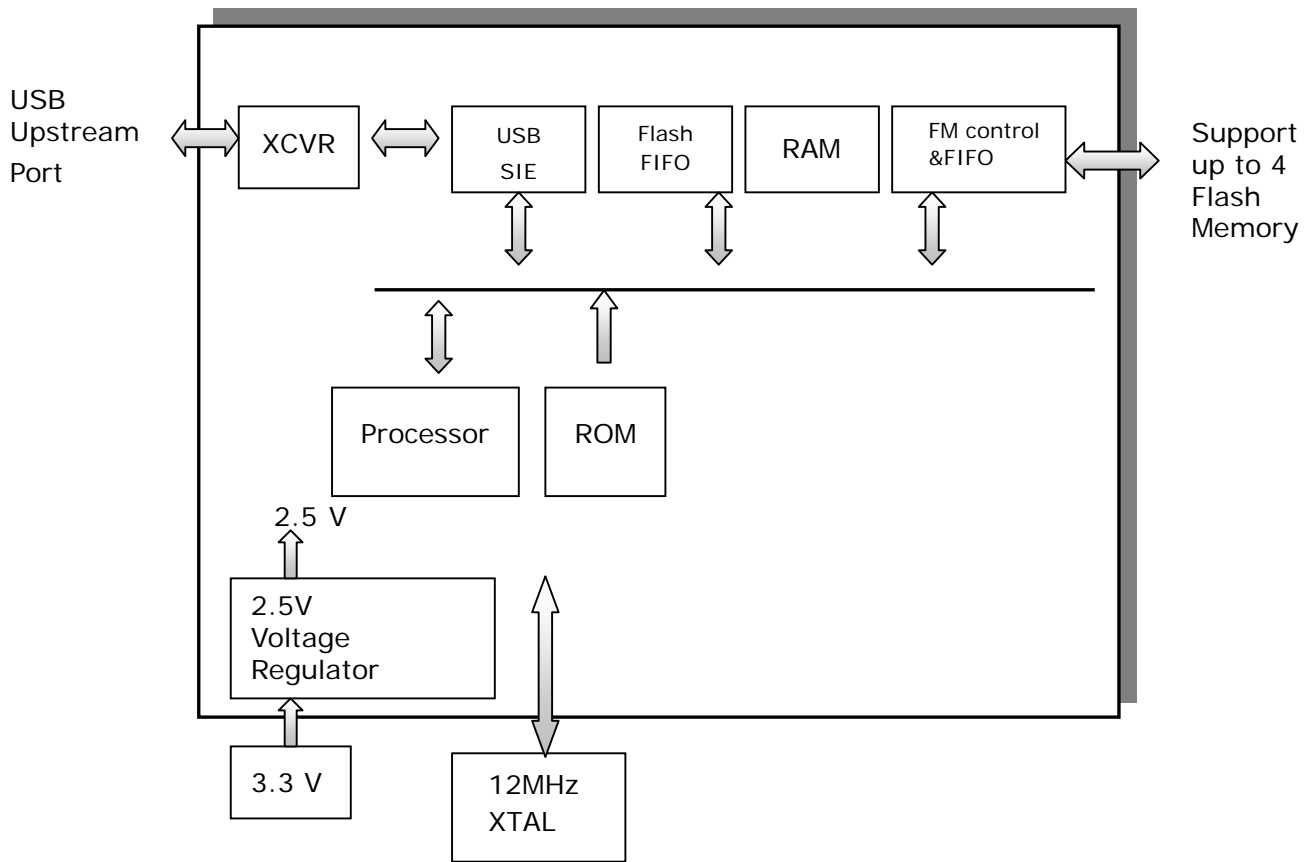



5.0. Electronic Characteristics

5.1 Absolute Maximum Ratings

Table 5.1 Absolute Maximum Ratings

SYMBOL	PARAMETER	RATING	UNITS
V _{CC}	Power Supply	-0.3 to V _{CC} +0.3	V
V _{IN}	Input Voltage	-0.3 to 3.6	V
V _{OUT}	Output Voltage	-0.3 to V _{CC} +0.3	V
T _{STG}	Storage Temperature	-40 to 150	°C

5.2 Recommended Operating Conditions

Table 5.2 Recommended Operating Conditions

SYMBOL	PARAMETER	MIN	TYP	MAX	UNITS
V _{CC}	Power Supply	3.0	3.3	3.6	V
V _{DD}	Digital Supply	2.25	2.5	2.75	
V _{IN}	Input Voltage	0	3.3	5.2	V
T _{OPR}	Operating Temperature	0		70	°C

5.3 Leakage Current and Capacitance

Table 5.3 General DC Characteristics

SYMBOL	PARAMETER	CONDITIONS	MIN	TYP	MAX	UNITS
I _{IN}	Input current	No pull-up or	-10	±1	10	μA
I _{OZ}	Tri-state leakage current		-10	±1	10	μA
C _{IN}	Input capacitance	Pad Limit		2.8		ρF
C _{OUT}	Output capacitance	Pad Limit		2.8		ρF
C _{BID}	Bi-directional buffer	Pad Limit		2.8		ρF



5.4 DC Electrical Characteristics of 3.3V I/O Cells

Table 5.4 DC Electrical Characteristics of 3.3V I/O Cells

SYMBOL	PARAMETER	CONDITIONS	Limits			UNIT
			MIN	TYP	MAX	
V _{CC}	Power supply	3.3V I/O	3.0	3.3	3.6	V
V _{il}	Input low voltage	LVTTTL			0.8	V
V _{ih}	Input high voltage		2.0			V
V _{ol}	Output low voltage	I _{ol} = 2~16mA			0.4	V
V _{oh}	Output high voltage	I _{oh} = 2~16mA	2.4			V
R _{pu}	Input pull-up resistance	PU=high, PD=low	40	75	190	KΩ
R _{pd}	Input pull-down resistance	PU=low, PD=high	40	75	190	KΩ
I _{in}	Input leakage current	V _{in} = V _{CC} or 0	-10	±1	10	μA
I _{oz}	Tri-state output leakage current		-10	±1	10	μA

5.5 USB Transceiver Characteristics

Table 5.5 Electrical characteristics

Symbol	Parameter	Conditions	Min.	Typ.	Max.	Unit
AVCC	Analog supply voltage		3.0	3.3	3.6	V
VCC	Digital supply voltage		2.25	2.5	2.75	V
I _{CC}	Operating supply current	High speed operating at 480 MHz			73	mA
I _{CC (susp)}	Suspend supply current	In suspend mode, current with 1.5kΩ pull-up resistor on pin RPU disconnected			120	μA



Table 5.6 Static characteristic : Digital pin

Symbol	Parameter	Conditions	Min.	Typ.	Max.	Unit
Input levels						
V _{IL}	Low-level input voltage				0.8	V
V _{IH}	High-level input voltage		2.0			V
Output levels						
V _{OL}	Low-level output voltage				0.2	V
V _{OH}	High-level output voltage		VCC-0.2			V

AVCC=3.0V~3.6V ; VCC=2.25V~2.75V ; Temp=0°C~115°C

Table 5.7 Static characteristic : Analog I/O pins (DP/DM)

Symbol	Parameter	Conditions	Min.	Typ.	Max.	Unit
USB2.0 Transceiver (HS)						
Input Levels (differential receiver)						
V _{HSDIFF}	High speed differential input sensitivity	$ V_{I(DP)} - V_{I(DM)} $ measured at the connection as application circuit	300			mV
V _{HSCM}	High speed data signaling common mode voltage range		-50		500	mV
V _{HSSQ}	High speed squelch detection threshold	Squelch detected			100	mV
		No squelch detected	150			mV
V _{HSDSC}	High speed disconnection detection threshold	Disconnection detected	625			mV
		Disconnection not detected			525	mV
Output Levels						
V _{HSOI}	High speed idle level output voltage(differential)		-10		10	mV
V _{HSOL}	High speed low level output voltage(differential)		-10		10	mV
V _{HSOH}	High speed high level output voltage(differential)		-360		400	mV



V_{CHIRPJ}	Chirp-J output voltage (differential)		700		1100	mV
V_{CHIRPK}	Chirp-K output voltage (differential)		-900		-500	mV
Resistance						
R_{DRV}	Driver output impedance	Equivalent resistance used as internal chip only	3	6	9	Ω
		Overall resistance including external resistor	40.5	45	49.5	
Termination						
V_{TERM}	Termination voltage for pull-up resistor on pin RPU		3.0		3.6	V
USB1.1 Transceiver (FS/LS)						
Input Levels (differential receiver)						
V_{DI}	Differential input sensitivity	$ V_{I(DP)} - V_{I(DM)} $	0.2			V
V_{CM}	Differential common mode voltage		0.8		2.5	V
Input Levels (single-ended receivers)						
V_{SE}	Single ended receiver threshold		0.8		2.0	V
Output levels						
V_{OL}	Low-level output voltage		0		0.3	V
V_{OH}	High-level output voltage		2.8		3.6	V



AVCC=3.0V~3.6V ; VCC=2.25V~2.75V ; Temp=0°C~115°C

Table 5.8 Dynamic characteristic : Analog I/O pins (DP/DM)

Symbol	Parameter	Conditions	Min.	Typ.	Max.	Unit
Driver Characteristics						
High-Speed Mode						
t _{HSR}	High-speed differential rise time		500			ps
t _{HSF}	High-speed differential fall time		500			ps
Full-Speed Mode						
t _{FR}	Rise time	CL=50pF ; 10 to 90% of V _{OH} -V _{OL} ;	4		20	ns
t _{FF}	Fall time	CL=50pF ; 90 to 10% of V _{OH} -V _{OL} ;	4		20	ns
t _{FRMA}	Differential rise/fall time matching (t _{FR} / t _{FF})	Excluding the first transition from idle mode	90		110	%
V _{CRS}	Output signal crossover voltage	Excluding the first transition from idle mode	1.3		2.0	V
Low-Speed Mode						
t _{LR}	Rise time	CL=200pF-600pF ; 10 to 90% of V _{OH} -V _{OL} ;	75		300	ns
t _{LF}	Fall time	CL=200pF-600pF ; 90 to 10% of V _{OH} -V _{OL} ;	75		300	ns
t _{LRMA}	Differential rise/fall time matching (t _{LR} / t _{LF})	Excluding the first transition from idle mode	80		125	%
V _{CRS}	Output signal crossover voltage	Excluding the first transition from idle mode	1.3		2.0	V
V _{OH}	High-level output voltage		2.8		3.6	V

6.0. Mechanical Information

Figure 6.1 Mechanical Information Diagram

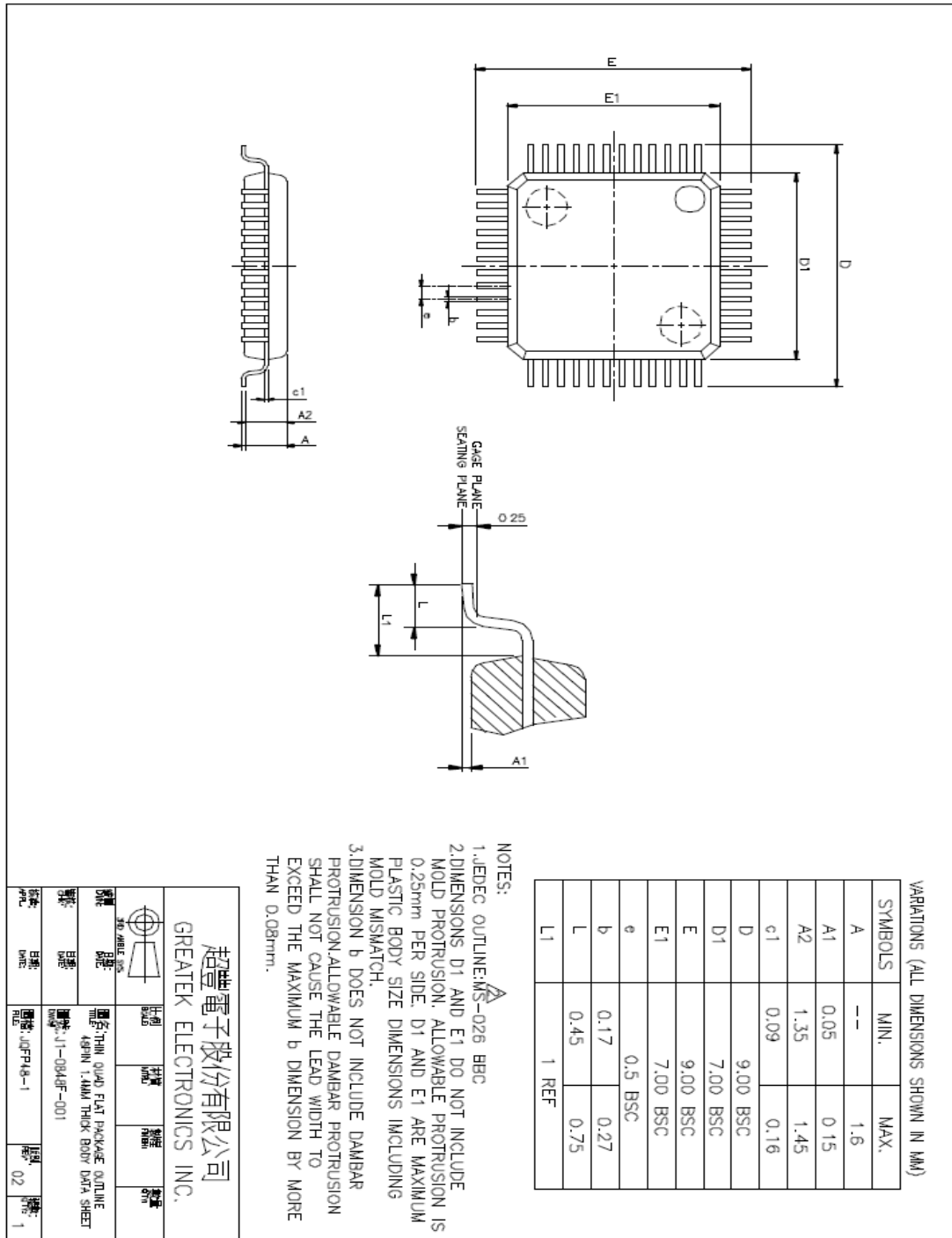



7.0. Abbreviation

This chapter lists and defines terms and abbreviations used throughout this specification

Autorun Automatically execute the customized images file to illustrate company logo or branding image.

iRUN The smart application – iRun handy tool for AU6386 to manage USB storage device.



【MEMO】

About Alcor Micro, Corp

Alcor Micro, Corp. designs, develops and markets highly integrated and advanced peripheral semiconductor, and software driver solutions for the personal computer and consumer electronics markets worldwide. We specialize in USB solutions and focus on emerging technology such as USB and IEEE 1394. The company offers a range of semiconductors including controllers for USB hub, integrated keyboard/USB hub and USB Flash memory card reader...etc. Alcor Micro, Corp. is based in Taipei, Taiwan, with sales offices in Taipei, Japan, Korea and California.

Alcor Micro is distinguished by its ability to provide innovative solutions for spec-driven products. Innovations like single chip solutions for traditional multiple chip products and on-board voltage regulators enable the company to provide cost-efficiency solutions for the computer peripheral device OEM customers worldwide.