

1A Fixed Low Dropout Positive Voltage Regulators

General Description

The RT9164B is designed for applications requiring low dropout performance at fully rated current. Additionally, the RT9164B provides excellent regulation over variations in line and load. Outstanding features include low dropout performance at rated current, fast transient response, internal current-limiting, and thermal-shutdown protection of the output device. The RT9164B available in space-saving TO-252 package.

Ordering Information

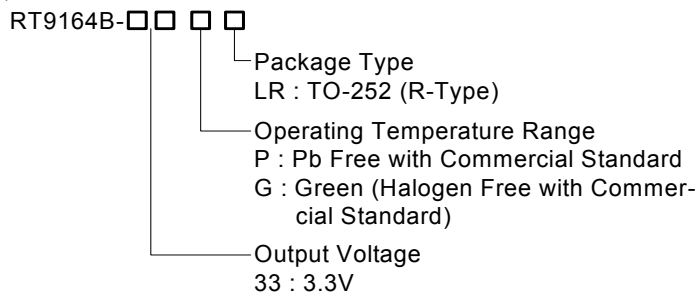

Note :

RichTek Pb-free and Green products are :

- ▶RoHS compliant and compatible with the current requirements of IPC/JEDEC J-STD-020.
- ▶Suitable for use in SnPb or Pb-free soldering processes.
- ▶100%matte tin (Sn) plating.

Typical Application Circuit

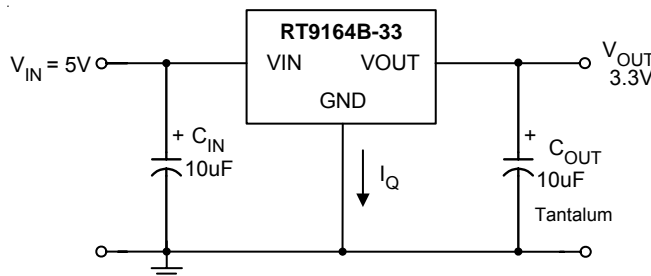

- (1) C_{IN} needed if device is far from filter capacitors.
- (2) C_{OUT} required for stability.

Features

- Low Dropout Performance, 1.4V Max.
- Full Current Rating Over Line and Temperature
- Fast Transient Response
- $\pm 0.5\%$ Output Voltage Accuracy
- RoHS Compliant and 100% Lead (Pb)-Free

Applications

- Active SCSI Termination
- Low Voltage Microcontrollers
- Switching Power Supply Post-Regulator

Pin ConFIGurations

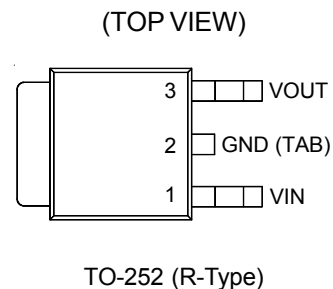

Function Block Diagram

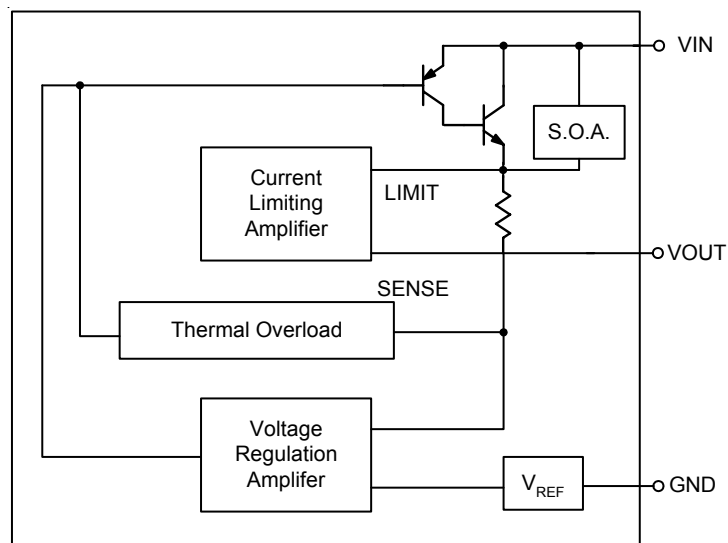

Functional Pin Description

Pin Name	Pin Function
GND	Ground
VOUT	Output Voltage
VIN	Power Input

Absolute Maximum Ratings (Note 1)

- Supply Input Voltage ----- 15V
- Power Dissipation, P_D @ $T_A = 25^\circ\text{C}$
 TO-252 ----- 1.471W
- Package Thermal Resistance (Note 6)
 TO-252, θ_{JA} ----- 68° C/W
 TO-252, θ_{JC} ----- 7.5° C/W
- Lead Temperature (Soldering, 10 sec.) ----- 260° C
- Junction Temperature ----- 150° C
- Storage Temperature Range ----- -65° C to 150° C
- ESD Susceptibility (Note 2)
 HBM (Human Body Mode) ----- 8 kV
 MM (Machine Mode) ----- 750V

Recommended Operating Conditions (Note 3)

- Supply Input Voltage ----- 3V to 12V
- Junction Temperature Range ----- -40° C to 125° C

Electrical Characteristics

($T_A = 25^\circ\text{C}$, unless otherwise specified)

Parameter	Symbol	Test Conditions	Min	Typ	Max	Units
Output Voltage (Note 4)	V_{OUT}	$I_{OUT} = 10\text{mA}$, $V_{IN} = 4.75\text{V}$, $T_J = 25^\circ\text{C}$	3.2835	3.3	3.3165	V
Line Regulation (Note 4)	ΔV_{LINE}	$I_{OUT} = 0\text{mA}$, $4.75\text{V} \leq V_{IN} \leq 15\text{V}$	--	1	6	mV
Load Regulation (Note 4)	ΔV_{LOAD}	$V_{IN} = 4.75\text{V}$, $0 \leq I_{OUT} \leq 1.0\text{A}$	--	1	12	mV
Dropout Voltage (Note 5)	V_{DROP}	$I_{OUT} = 500\text{mA}$	--	1.15	1.25	V
		$I_{OUT} = 1.0\text{A}$	--	1.3	1.4	V
Current Limit	I_{LIM}	$V_{IN} = 5\text{V}$	1.0	1.8	--	A
Quiescent Current	I_Q	$V_{IN} = 5\text{V}$	--	5	10	mA
Ripple Rejection	PSRR	$f_{RIPPLE} = 120\text{Hz}$, $(V_{IN} - V_{OUT}) = 2\text{V}$, $V_{RIPPLE} = 1\text{V}_{P-P}$	--	72	--	dB

Note 1. Stresses listed as the above “Absolute Maximum Ratings” may cause permanent damage to the device. These are for stress ratings. Functional operation of the device at these or any other conditions beyond those indicated in the operational sections of the specifications is not implied. Exposure to absolute maximum rating conditions for extended periods may remain possibility to affect device reliability.

Note 2. Devices are ESD sensitive. Handling precaution recommended.

Note 3. The device is not guaranteed to function outside its operating conditions.

Note 4. Low duty cycle pulse testing with Kelvin connections.

Note 5. The dropout voltage is defined as $V_{IN} - V_{OUT}$, which is measured when V_{OUT} is $V_{OUT(NORMAL)} - 100\text{mV}$.

Note 6. θ_{JA} is measured in the natural convection at $T_A = 25^\circ\text{C}$ on a low effective thermal conductivity test board of JEDEC 51-3 thermal measurement standard. The case point of θ_{JC} is on the center of the exposed pad. The pad size is 100mm^2 on TO-252 package.

Typical Operating Characteristics

Output Voltage vs. Temperature

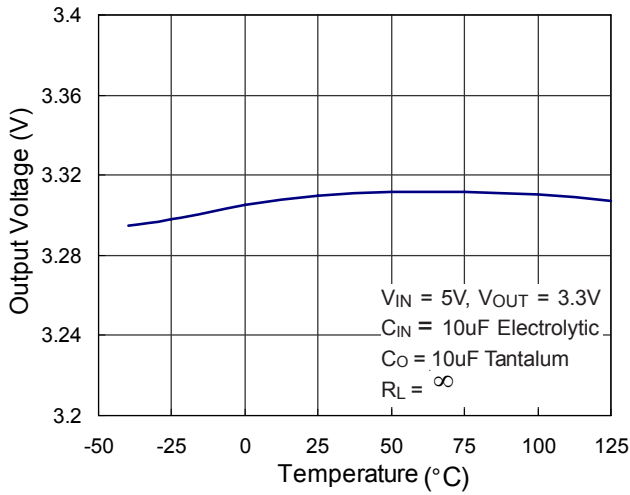

Line Transient Response

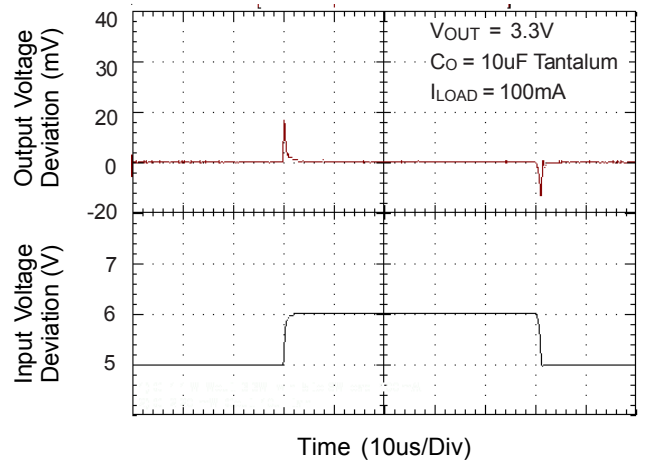

Load Transient Response

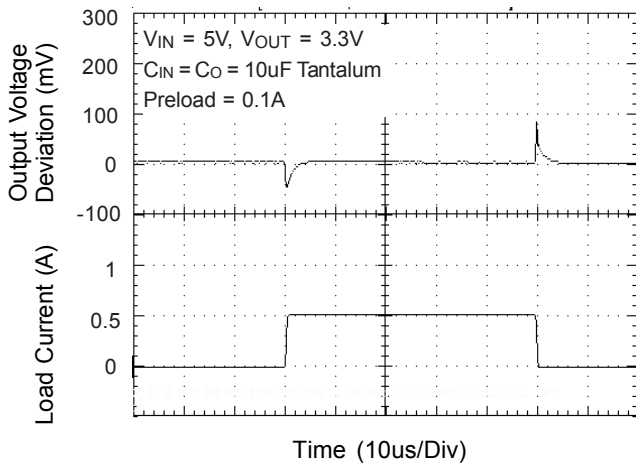

Load Transient Response

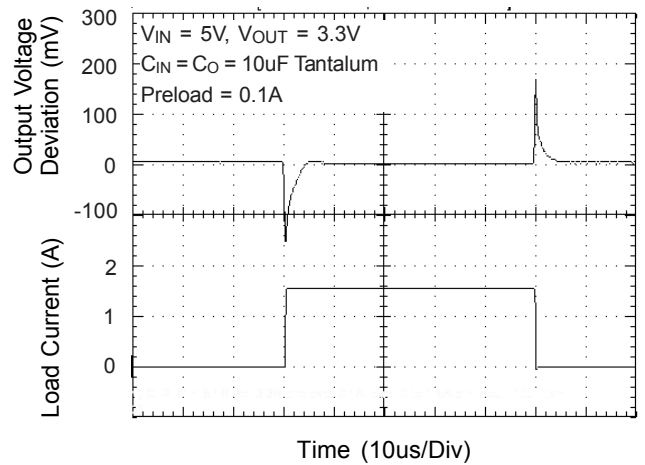

Application Information

Input Bypass Capacitor

An input capacitor is recommended. A 10µF tantalum on the input is a suitable input bypassing for almost all applications.

Output Capacitor

RT9164B requires a capacitor from V_{OUT} to GND to provide compensation feedback to the internal gain stage. This is to ensure stability at the output terminal. Typically, 10µF tantalum or 50µF aluminum electrolytic with 30mΩ to 2Ω range capacitor is sufficient.

The output capacitor does not have a theoretical upper limit and increasing its value will increase stability. C_{OUT} = 100µF or more is typical for high current regulator design.

Region of Stable C_{OUT} ESR vs. Load Current

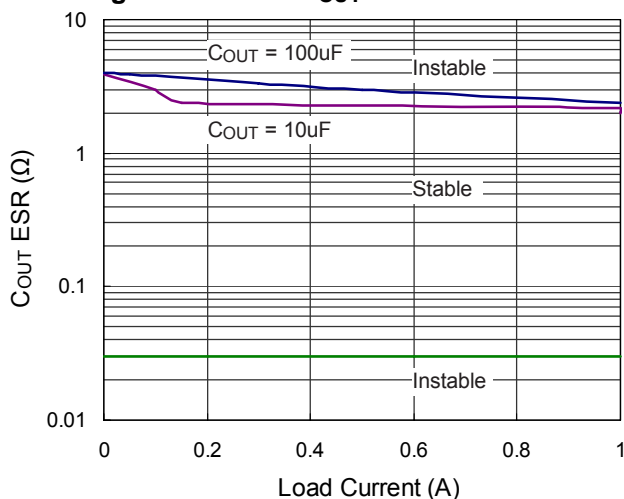

Thermal Protection

RT9164B has thermal protection which limits junction temperature to 150°C. However, device functionality is only guaranteed to a maximum junction temperature of +125°C. The power dissipation and junction temperature for RT9164B are given by

$$P_D = (V_{IN} - V_{OUT}) \times I_{OUT}$$

$$T_{JUNCTION} = T_{AMBIENT} + (P_D \times \theta_{JA})$$

Note: T_{JUNCTION} must not exceed 125°C

Current Limit Protection

RT9164B is protected against overload conditions. Current protection is triggered at typically 1.8A.

Thermal Consideration

The RT9164B contains thermal limiting circuitry designed to protect itself from over-temperature conditions. Even for normal load conditions, maximum junction temperature ratings must not be exceeded. As mention in thermal protection section, we need to consider all sources of thermal resistance between junction and ambient. It includes junction-to-case, case-to-heat-sink interface, and heat sink thermal resistance itself.

Junction-to-case thermal resistance is specified from the IC junction to the bottom of the case directly below the die. Proper mounting is required to ensure the best possible thermal flow from this area of the package to the heat sink. The case of all devices in this series is electrically connected to the output. Therefore, if the case of the device must be electrically isolated, a thermally conductive spacer is recommended.

Outline Dimension

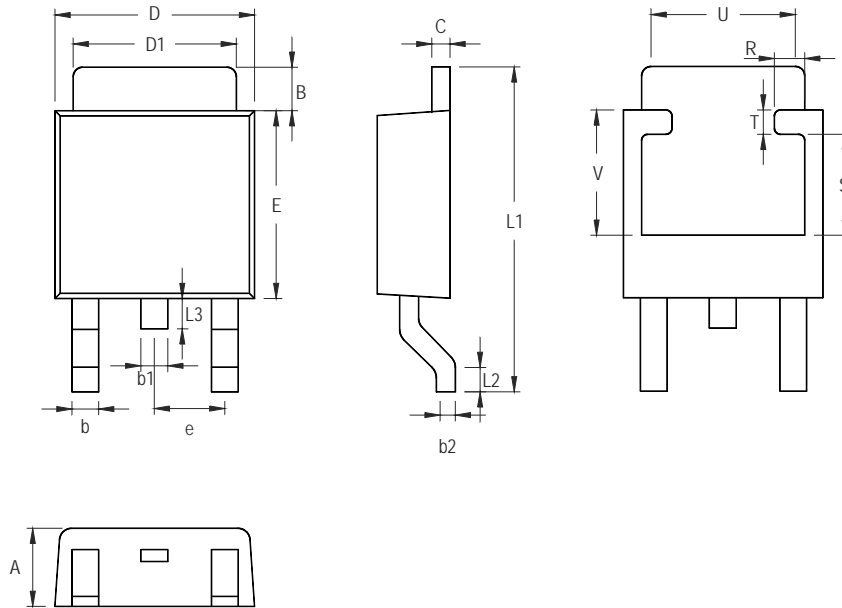

Symbol	Dimensions In Millimeters		Dimensions In Inches	
	Min	Max	Min	Max
A	2.184	2.388	0.086	0.094
B	0.889	2.032	0.035	0.080
b	0.508	0.889	0.020	0.035
b1	1.016 Ref.		0.040 Ref.	
b2	0.457	0.584	0.018	0.023
C	0.457	0.584	0.018	0.023
D	6.350	6.731	0.250	0.265
D1	5.207	5.461	0.205	0.215
E	5.334	6.223	0.210	0.245
e	2.108	2.438	0.083	0.096
L1	9.398	10.414	0.370	0.410
L2	0.508 Ref.		0.020 Ref.	
L3	0.635	1.016	0.025	0.040
U	3.810 Ref.		0.150 Ref.	
V	3.048 Ref.		0.120 Ref.	
R	0.200	0.850	0.008	0.033
S	2.500	3.400	0.098	0.134
T	0.500	0.850	0.020	0.033

3-Lead TO-252 Surface Mount Package

Richtek Technology Corporation

Headquarter

5F, No. 20, Taiyuen Street, Chupei City

Hsinchu, Taiwan, R.O.C.

Tel: (8863)5526789 Fax: (8863)5526611

Richtek Technology Corporation

Taipei Office (Marketing)

8F, No. 137, Lane 235, Paochiao Road, Hsintien City

Taipei County, Taiwan, R.O.C.

Tel: (8862)89191466 Fax: (8862)89191465

Email: marketing@richtek.com