

Driver circuit for Si photodiode array C9004

Driver circuit for 16-element photodiode array

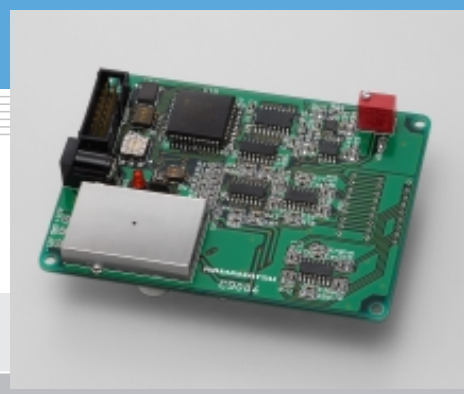

Features

- High precision and high-speed measurement by simultaneous 16-channel readout
- Assembled with pulse generator (8-step adjustable oscillatory frequency)
CLK, START, A/D conversion Trig and $\overline{\text{EOS}}$ pulse output
- Choice of gain (conversion impedance): 1×10^6 or 1×10^7 (V/A)
- Hamamatsu S4111-16 series, S5668 series photodiode arrays are directly mountable on board.
- Single power supply operation: +12 V

Applications

- Performance evaluation of Hamamatsu S4111-16 series, S5668 series photodiode arrays
- Position measurement
- Displacement measurement

Absolute maximum ratings

Parameter	Symbol	Value	Unit
Supply voltage	Vcc Max.	+18	V
Input current	Iin Max.	$+6.7 \times 10^{-5}$	A
Operating temperature	Topr	0 to +50	°C
Storage temperature	Tstg	-20 to +80	°C

Electrical and optical characteristics (Ta=25 °C)

Parameter	Symbol	Condition	Min.	Typ.	Max.	Unit
Input current range	Iin	Tz=1 × 10 ⁶	-	-	1 × 10 ⁻⁵	A
		Tz=1 × 10 ⁷	-	-	1 × 10 ⁻⁶	A
Conversion impedance *1	Tz		1 × 10 ⁶	-	1 × 10 ⁷	V/A
Output offset voltage	Vos	Tz=1 × 10 ⁶ (set up prior to shipping)	-	0.025	-	V
		Tz=1 × 10 ⁷ *2	-	0.25	-	V
Output amplitude voltage	Vo	Tz=1 × 10 ⁶ , RL=1 kΩ	0	-	+10	V
		Tz=1 × 10 ⁷ , RL=1 kΩ	0	-	+10	V
Output noise voltage	enp-p	Tz=1 × 10 ⁶ (full bandwidth)	-	5	-	mVp-p
		Tz=1 × 10 ⁷ (full bandwidth)	-	10	-	mVp-p
Rise time	tr	Tz=1 × 10 ⁶ , RL=1 kΩ	-	5.6	-	μs
		Tz=1 × 10 ⁷ , RL=1 kΩ	-	5.6	-	μs
Capacitive load	CL		-	-	100	pF
Oscillatory frequency (OUT) *3	CLK		1.5625	-	200	kHz
Start pulse width (OUT) *3	-		5	-	640	μs
Output format *4	-		TTL			-
Current consumption	Icc		-	200	250	mA

*1: Conversion impedance can be changed with the switch on the circuit board.

*2: The variable resistor VR on the circuit board must be used for making offset adjustments.

*3: Adjustable in 8 steps by using the BCD rotary switch on the circuit board.

*4: CLK, START, Trig and $\overline{\text{EOS}}$ pulse output format.

■ Block diagram

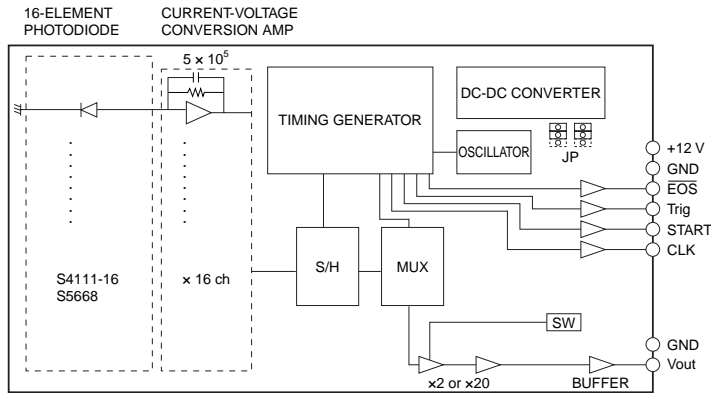

KACCC0181EB

■ Timing chart

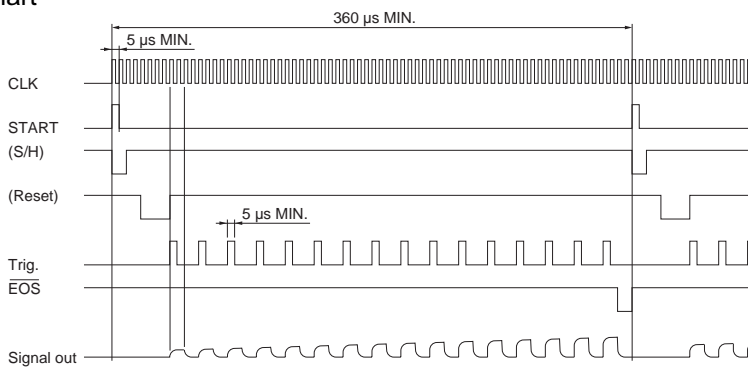

KACCC0182EA

■ Dimensional outline (unit: mm)

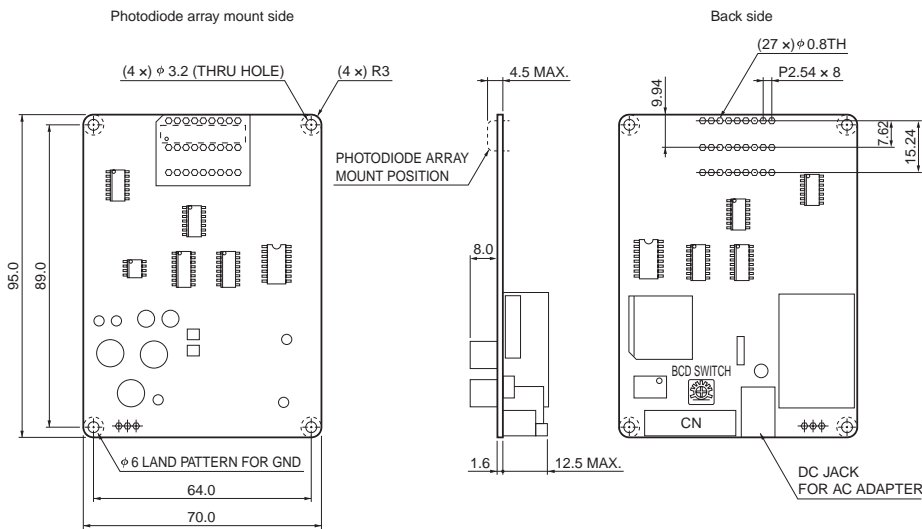

NOTE) Photodiode array sold separately

KACCA0117EB

■ Accessories

- Dedicated AC adapter
- Flat cable (20 cm) with I/O connector receptacle

HAMAMATSU

Information furnished by HAMAMATSU is believed to be reliable. However, no responsibility is assumed for possible inaccuracies or omissions. Specifications are subject to change without notice. No patent rights are granted to any of the circuits described herein. ©2006 Hamamatsu Photonics K.K.

HAMAMATSU PHOTONICS K.K., Solid State Division

1126-1 Ichino-cho, Higashi-ku, Hamamatsu City, 435-8558 Japan, Telephone: (81) 53-434-3311, Fax: (81) 53-434-5184, www.hamamatsu.com

U.S.A.: Hamamatsu Corporation: 360 Foothill Road, P.O.Box 6910, Bridgewater, N.J. 08807-0910, U.S.A., Telephone: (1) 908-231-0960, Fax: (1) 908-231-1218

Germany: Hamamatsu Photonics Deutschland GmbH: Arzbergerstr. 10, D-82211 Herrsching am Ammersee, Germany, Telephone: (49) 08152-3750, Fax: (49) 08152-2658

France: Hamamatsu Photonics France S.A.R.L.: 19, Rue du Saule Trapu, Parc du Moulin de Massy, 91882 Massy Cedex, France, Telephone: 33-(1) 69 53 71 00, Fax: 33-(1) 69 53 71 10

United Kingdom: Hamamatsu Photonics UK Limited: 2 Howard Court, 10 Tewin Road, Welwyn Garden City, Hertfordshire AL7 1BW, United Kingdom, Telephone: (44) 1707-294888, Fax: (44) 1707-325777

North Europe: Hamamatsu Photonics Norden AB: Smidesvägen 12, SE-171 41 Solna, Sweden, Telephone: (46) 8-509-031-00, Fax: (46) 8-509-031-01

Italy: Hamamatsu Photonics Italia S.R.L.: Strada della Moia, 1/E, 20020 Arese, (Milano), Italy, Telephone: (39) 02-935-81-733, Fax: (39) 02-935-81-741