

TOSHIBA Bipolar Linear Integrated Circuit Silicon Monolithic

TA7733F/FG

Functional Bridge Driver

The TA7733 is a low-voltage bridge driver IC offering four modes: forward rotation, reverse rotation, stop, and brake.

Features

- Wide operating supply voltage range:
V_{CC} (opr.) = 1.8~15 V
- Housed in a flat package (16-pin)
- Forward and reverse rotation, stop and brake modes are available by means of rotation control signals.
- High efficiency is obtained
- Can be used as an interface driver.

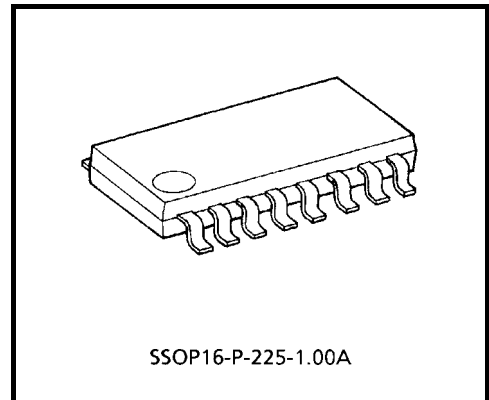

Weight: 0.14 g (typ.)

Block Diagram

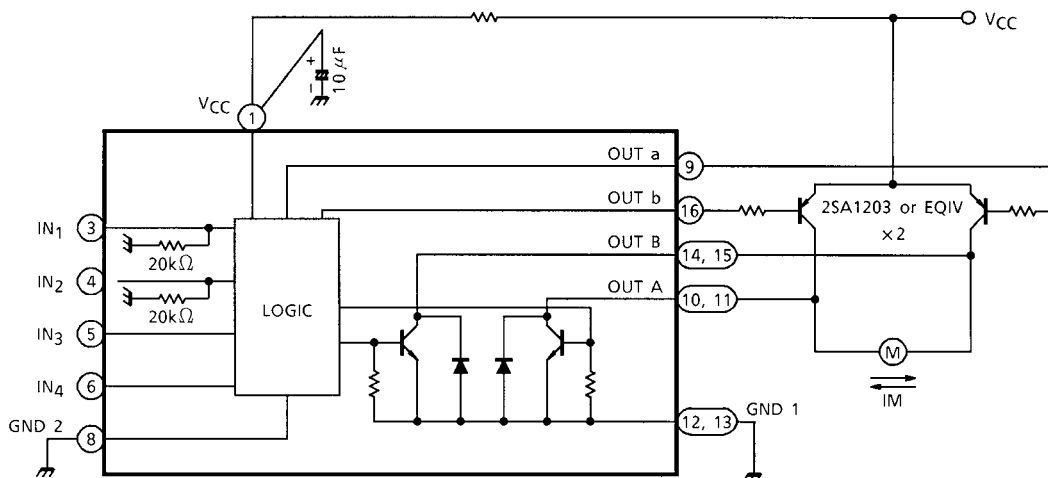

The TA7733FG is a Pb-free product.
The following conditions apply to solderability:
*Solderability

1. Use of Sn-37Pb solder bath
 - *solder bath temperature = 230°C
 - *dipping time = 5 seconds
 - *number of times = once
 - *use of R-type flux
2. Use of Sn-3.0Ag-0.5Cu solder bath
 - *solder bath temperature = 245°C
 - *dipping time = 5 seconds
 - *number of times = once
 - *use of R-type flux

Pin Description

Pin No.	Symbol	Functional Description	
1	V _{CC}	Power supply voltage terminal	
2	NC	No connection	
3	IN ₁	Signal input terminal	Truth table 1
4	IN ₂	Signal input terminal	
5	IN ₃	Signal input terminal	
6	IN ₄	Signal input terminal	
7	NC	No connection	
8	GND 2	Logic GND	
9	OUT a	Output A upper transistor drive terminal	
10	OUT A	Output A	
11	OUT A		
12	GND 1	Power GND terminal	
13	GND 1		
14	OUT B	Output B	
15	OUT B		
16	OUT b	Output B upper transistor drive terminal	

Functions

(1) Bridge driver (truth table 1)

CONTROL	INPUT MODE				OUTPUT				OPERATING MODE	NOTE
	IN ₁	IN ₂	IN ₃	IN ₄	OUT A	OUT B	OUT a	OUT b		
2-input control	H	L	H	H	ON (-500 mA)	—	ON (-25 mA)	—	Forward rotation	—
	L	H	H	H	—	ON (-500 mA)	—	ON (-25 mA)	Reverse rotation	
	H	H	H	H	ON (-500 mA)	ON (-500 mA)	—	—	Brake	
	L	L	H	H	—	—	—	—	Stop	
1-input control	H	L	L	H	ON (-500 mA)	—	ON (-25 mA)	—	A ON	
	L	L	L	H	—	ON (-500 mA)	—	ON (-25 mA)	B ON	
	H / L	H	L	H	ON (-500 mA)	ON (-500 mA)	—	—	AB ON	
	—	—	—	L	—	—	—	—	INHIBIT	LOW ≤ 0.6 V

(2) Interface driver application

If IN₃ and IN₄ connect to "HIGH", Out A and Out B can be used as interface driver outputs for each input. (Connect Out a and Out b to GND.)

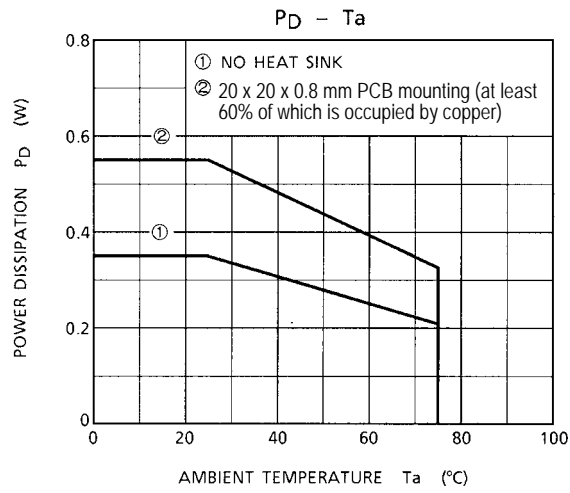

Input-Output Circuit

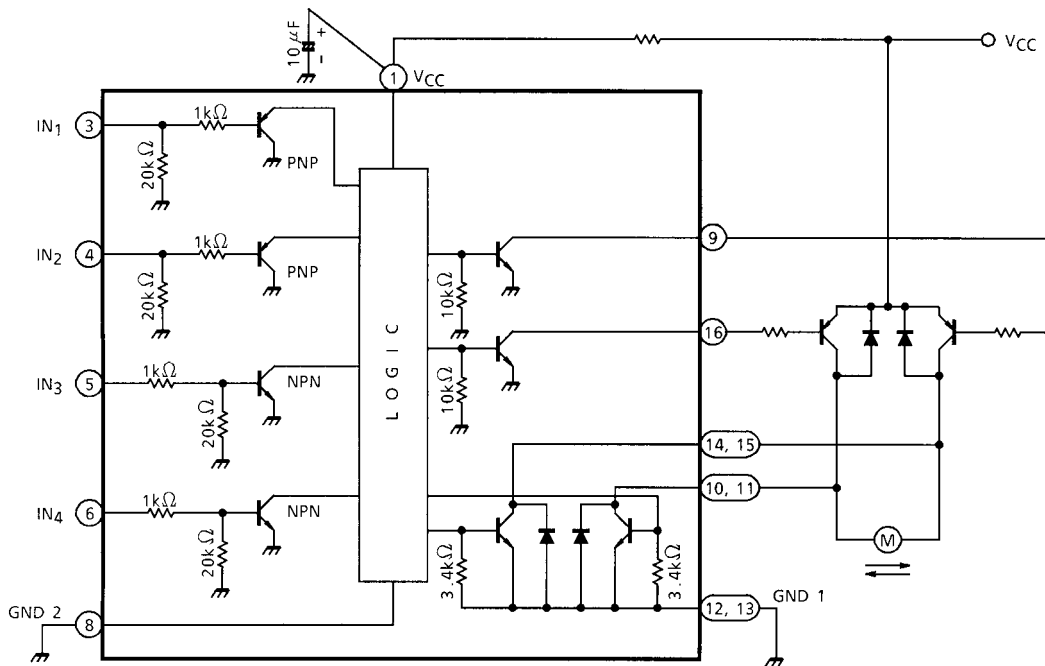

Absolute Maximum Ratings (Ta = 25°C)

Characteristic	Symbol	Rating	Unit
Peak supply voltage	V _{CC}	18	V
Output current	I _O (AVE.)	0.5	A
Power dissipation	P _D	350 (Note 1)	mW
		550 (Note 2)	
Operating temperature	T _{opr}	-30~75	°C
Storage temperature	T _{stg}	-55~150	°C

Note 1: No heat sink

Note 2: This rating is obtained when the product is mounted on a 50 × 50 × 1.6 mm PCB of which 60% or more is occupied by copper.

Electrical Characteristics (unless otherwise specified, Ta = 25°C, V_{CC} = 5 V)

Characteristic	Symbol	Test Circuit	Test Condition	Min	Typ.	Max	Unit
Supply current	I _{CC1}	1	Output open, CW / CCW mode	—	13	—	mA
	I _{CC2}	1	Output open, stop mode	—	7.2	—	
	I _{CC3}	1	Output open, brake mode	—	19.2	—	
	I _{CC4}	1	Inhibit (INPUT4 = "L")	—	2.4	—	
OUTPUT saturation voltage	V _{sat1}	2	I _{O1} = 500 mA, lower side (Output A, B)	—	0.4	—	V
	V _{sat2}	2	I _{O2} = 25 mA, upper side (Output a, b)	—	0.5	—	
Output TR leakage current	I _L	3	V _C = 15 V	—	—	50	μA
Input voltage	"H" level	V _{IN 1, 2} (H)	—	1.2	—	V _{CC}	V
	"L" level	V _{IN 1, 2} (L)	—	—	—	0.3	
Input current	"L" level	I _{IN1, 2}	4	Input "L" (source current)		20	μA
Input voltage	"H" level	V _{IN 3, 4} (H)	—	1.0	—	V _{CC}	V
	"L" level	V _{IN 3, 4} (L)	—	—	—	0.3	
Input current	"H" level	I _{IN3, 4}	4	Input "H" (sink current) V _{IN} = 1 V		30	μA
Diode forward voltage	V _F	5	I _F = 0.5 A, V _{CC} = 0 V	—	1	—	V

Tests Circuits

1. $I_{cc1, 2, 3, 4}$

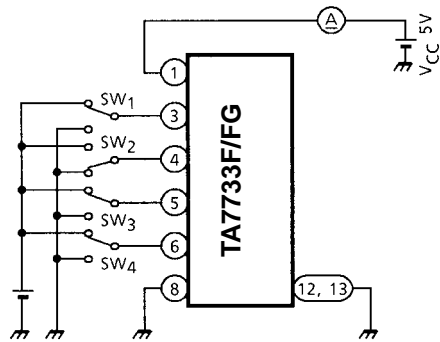

2. $V_{sat1, 2}$

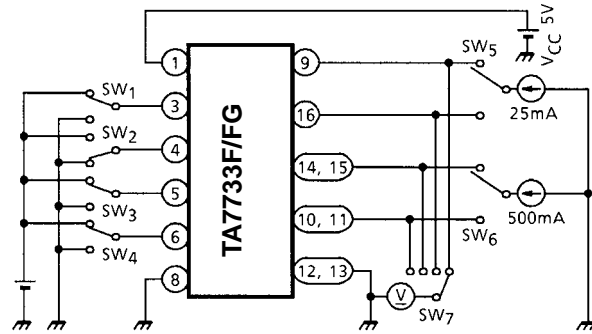

3. I_L

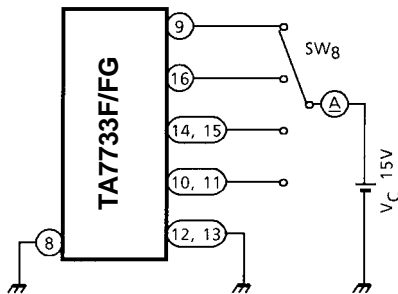

4. I_{IN}

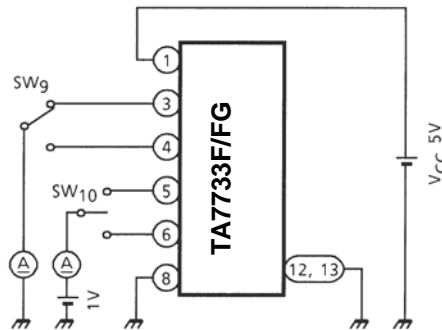

5. V_F

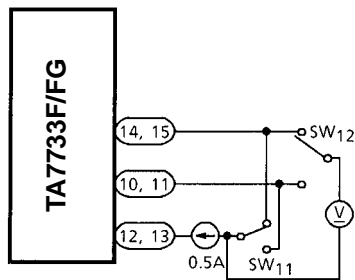

Notes on Using the TA7733F/FG

The TA7733F/FG functionable bridge driver is an IC specifically developed to control rotation switching in brush motors. This IC has been carefully designed and strengthened to withstand counter-electromotive force or startup rush current, which are problems often associated with driving brush motors.

However, as with other power ICs, application circuits must be designed not to apply surge voltage or excess current that exceeds the standard values. In addition, when designing PCBs, make sure the wiring pattern does not cause oscillation, which can result in equipment malfunction or destruction of the IC.

The following are notes on use of the TA7733F/FG. These should be reflected at the design stage.

(1) Power supply voltage

To avoid the motor current affecting the TA7733F/FG control-side power supply, we recommend you use two power supplies: an external transistor power supply, and a TA7733F/FG control-side power supply. However, when using a single power supply, connect as in the diagram below.

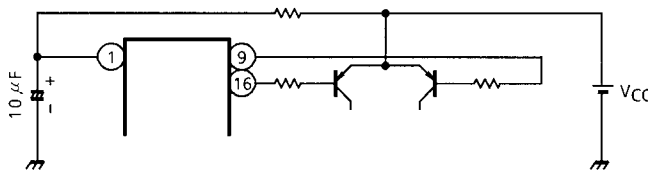

(2) Maximum voltage and current

The maximum supply voltage (pin 1) for the TA7733F/FG is 18 V. The operating supply voltage is in the range of 1.8~15 V. No voltage exceeding this range should be applied to pin 1.

The maximum current is 0.5 A (ave.) or 1.5 A (peak). The circuit should be designed so that rush current at startup does not exceed peak current, and average current during steady operation does not exceed 0.5 A.

(3) External diodes

As the block diagram shows, the TA7733F/FG has internal diodes.

The lower two diodes, which are the IC's internal parasitic diodes, have a relatively large capacitance. However, when a motor with a large reactance such as a core motor is driven, the upper two diodes may be damaged by the motor's counter-electromotive force. In such a case, connect external diodes in parallel. The lower diodes should not be subjected to high current. For brake operation, therefore, external diodes should be connected.

(4) PCB design

The following points concern the TA7733F/FG pattern design around the power supply line (pin 1) and the pattern design of the GND (pin 8, pin 12 / 13).

- Ensure that the bypass capacitor between pin 1, and GND does not share impedance with other lines.
- The GND line should not be shared by other circuits.
- The capacitance of the bypass capacitor should be as large as possible.

(5) Oscillation remedies

To prevent noise from sparks when using brush motors, a capacitor may be connected between both pins.

When using the TA7733F/FG, the capacitor is connected between outputs (pins 10 / 11, and pins 14 / 15). This may cause oscillation. Therefore avoid connecting the capacitor where possible. If connection is necessary to overcome noise, connect resistors in series as shown in the technical data.

The values for the capacitor and resistors must be determined according to the motor.

Note: Utmost care is necessary in the design of the output, VCC, VM, and GND lines since the IC may be destroyed by short-circuiting between outputs, air contamination faults, or faults due to improper grounding, or by short-circuiting between contiguous pins.

Package Dimensions

SSOP16-P-225-1.00A

Unit: mm

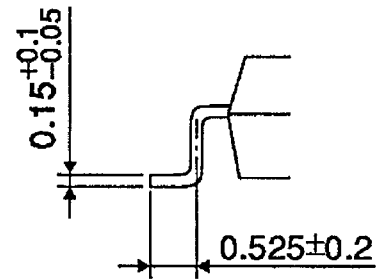
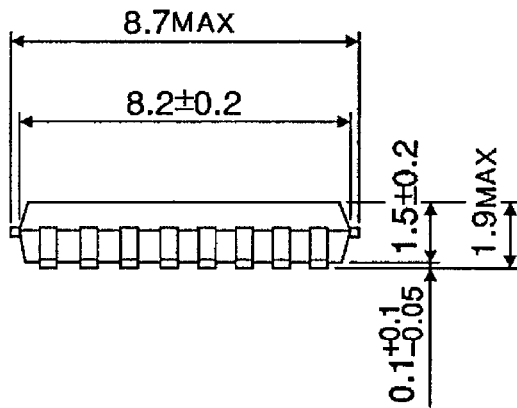
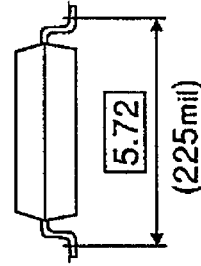
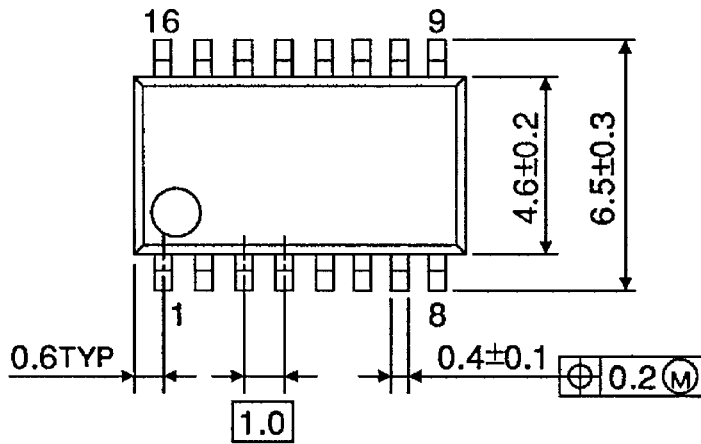

Weight: 0.14 g (typ.)

Notes on Contents

1. Block Diagrams

Some of the functional blocks, circuits, or constants in the block diagram may be omitted or simplified for explanatory purposes.

2. Equivalent Circuits

The equivalent circuit diagrams may be simplified or some parts of them may be omitted for explanatory purposes.

3. Timing Charts

Timing charts may be simplified for explanatory purposes.

4. Application Circuits

The application circuits shown in this document are provided for reference purposes only. Thorough evaluation is required, especially at the mass production design stage.

Toshiba does not grant any license to any industrial property rights by providing these examples of application circuits.

5. Test Circuits

Components in the test circuits are used only to obtain and confirm the device characteristics. These components and circuits are not guaranteed to prevent malfunction or failure from occurring in the application equipment.

IC Usage Considerations

Notes on handling of ICs

- [1] The absolute maximum ratings of a semiconductor device are a set of ratings that must not be exceeded, even for a moment. Do not exceed any of these ratings.
Exceeding the rating(s) may cause the device breakdown, damage or deterioration, and may result injury by explosion or combustion.
- [2] Use an appropriate power supply fuse to ensure that a large current does not continuously flow in case of over current and/or IC failure. The IC will fully break down when used under conditions that exceed its absolute maximum ratings, when the wiring is routed improperly or when an abnormal pulse noise occurs from the wiring or load, causing a large current to continuously flow and the breakdown can lead smoke or ignition. To minimize the effects of the flow of a large current in case of breakdown, appropriate settings, such as fuse capacity, fusing time and insertion circuit location, are required.
- [3] If your design includes an inductive load such as a motor coil, incorporate a protection circuit into the design to prevent device malfunction or breakdown caused by the current resulting from the inrush current at power ON or the negative current resulting from the back electromotive force at power OFF. IC breakdown may cause injury, smoke or ignition.
Use a stable power supply with ICs with built-in protection functions. If the power supply is unstable, the protection function may not operate, causing IC breakdown. IC breakdown may cause injury, smoke or ignition.
- [4] Do not insert devices in the wrong orientation or incorrectly.
Make sure that the positive and negative terminals of power supplies are connected properly. Otherwise, the current or power consumption may exceed the absolute maximum rating, and exceeding the rating(s) may cause the device breakdown, damage or deterioration, and may result injury by explosion or combustion.
In addition, do not use any device that is applied the current with inserting in the wrong orientation or incorrectly even just one time.

Points to remember on handling of ICs**(1) Heat Radiation Design**

In using an IC with large current flow such as power amp, regulator or driver, please design the device so that heat is appropriately radiated, not to exceed the specified junction temperature (T_J) at any time and condition. These ICs generate heat even during normal use. An inadequate IC heat radiation design can lead to decrease in IC life, deterioration of IC characteristics or IC breakdown. In addition, please design the device taking into consideration the effect of IC heat radiation with peripheral components.

(2) Back-EMF

When a motor rotates in the reverse direction, stops or slows down abruptly, a current flows back to the motor's power supply due to the effect of back-EMF. If the current sink capability of the power supply is small, the device's motor power supply and output pins might be exposed to conditions beyond maximum ratings. To avoid this problem, take the effect of back-EMF into consideration in system design.

RESTRICTIONS ON PRODUCT USE

060116EBA

- The information contained herein is subject to change without notice. 021023_D
- TOSHIBA is continually working to improve the quality and reliability of its products. Nevertheless, semiconductor devices in general can malfunction or fail due to their inherent electrical sensitivity and vulnerability to physical stress. It is the responsibility of the buyer, when utilizing TOSHIBA products, to comply with the standards of safety in making a safe design for the entire system, and to avoid situations in which a malfunction or failure of such TOSHIBA products could cause loss of human life, bodily injury or damage to property.
In developing your designs, please ensure that TOSHIBA products are used within specified operating ranges as set forth in the most recent TOSHIBA products specifications. Also, please keep in mind the precautions and conditions set forth in the "Handling Guide for Semiconductor Devices," or "TOSHIBA Semiconductor Reliability Handbook" etc. 021023_A
- The TOSHIBA products listed in this document are intended for usage in general electronics applications (computer, personal equipment, office equipment, measuring equipment, industrial robotics, domestic appliances, etc.). These TOSHIBA products are neither intended nor warranted for usage in equipment that requires extraordinarily high quality and/or reliability or a malfunction or failure of which may cause loss of human life or bodily injury ("Unintended Usage"). Unintended Usage include atomic energy control instruments, airplane or spaceship instruments, transportation instruments, traffic signal instruments, combustion control instruments, medical instruments, all types of safety devices, etc. Unintended Usage of TOSHIBA products listed in this document shall be made at the customer's own risk. 021023_B
- The products described in this document shall not be used or embedded to any downstream products of which manufacture, use and/or sale are prohibited under any applicable laws and regulations. 060106_Q
- The information contained herein is presented only as a guide for the applications of our products. No responsibility is assumed by TOSHIBA for any infringements of patents or other rights of the third parties which may result from its use. No license is granted by implication or otherwise under any patent or patent rights of TOSHIBA or others. 021023_C
- The products described in this document are subject to the foreign exchange and foreign trade laws. 021023_E