

### TRANSIENT VOLTAGE SUPPRESSOR

**BREAKDOWN VOLTAGE: 5.8 --- 376 V**  
**PEAK PULSE POWER: 600 W**

#### FEATURES

Plastic package has Underwriters Laboratory  
 Flammability Classification 94V-0  
 Glass passivated junction  
 600W peak pulse power capability with a 10/1000µs  
 waveform, repetition rate (duty cycle): 0.01%  
 Excellent clamping capability  
 Fast response time: typically less than 1.0ps from 0 Volts to  
 $V_{(BR)}$  for uni-directional and 5.0ns for bi-directional types  
 Devices with  $V_{(BR)} = 10V I_D$  are typically  $I_D$  less than 1.0 µA  
 High temperature soldering guaranteed: 265 / 10 seconds,  
 0.375"(9.5mm) lead length, 5lbs. (2.3kg) tension

#### MECHANICAL DATA

Case: JEDEC DO-15, molded plastic body over  
 passivated junction  
 Terminals: Axial leads, solderable per MIL-STD-750,  
 method 2026  
 Polarity: For uni-directional types the color band denotes  
 the cathode, which is positive with respect to the  
 anode under normal TVS operation  
 Weight: 0.014 ounces, 0.39 grams  
 Mounting position: Any

#### DO - 15

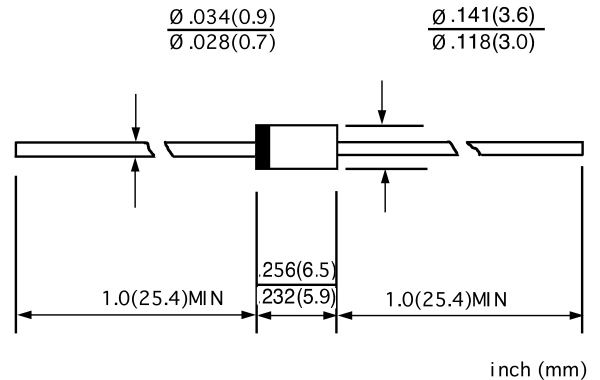

#### DEVICES FOR BIDIRECTIONAL APPLICATIONS

For bi-directional use add suffix letter "B" (e.g. BZW06P-6V4B).  
 Electrical characteristics apply in both directions.

#### MAXIMUM RATINGS AND CHARACTERISTICS

Ratings at 25 °C ambient temperature unless otherwise specified.

	SYMBOL	VALUE	UNIT
Peak power dissipation with a 10/1000µs waveform (NOTE 1, FIG. 1)	$P_{PPM}$	Minimum 600	W
Peak pulse current with a 10/1000µs waveform (NOTE 1)	$I_{PPM}$	SEE TABLE 1	A
Steady state power dissipation at $T_L=75$ Lead lengths 0.375"(9.5mm) (NOTE 2)	$P_{M(AV)}$	3.0	W
Peak forward surge current, 8.3ms single half Sine-wave superimposed on rated load (JEDEC Method)	$I_{FSM}$	100.0	A
Thermal resistance junction to lead junction to ambient lead = 10mm	$R_{\theta JL}$ $R_{\theta JA}$	60 100	$^{\circ}W$
Operating junction and storage temperature range	$T_J, T_{STG}$	-55---+175	

NOTES: (1) Non-repetitive current pulse, per Fig. 3 and derated above  $T_A = 25^{\circ}C$  per Fig. 2

Rating is 500W between 40V and 188V types. For a surge greater than the maximum values, the diode will short circuit.

(2) Mounted on copper pad area of 1.6 x 1.6" (40 x 40mm) per Fig. 5

www.galaxycn.com

**ELECTRICAL CHARACTERISTICS at(T<sub>A</sub>=25 unless otherwise noted)**

**TABLE 1(Cont' d)**

Device Type		I <sub>D</sub> @ V <sub>MW</sub> (max)		V <sub>(BR)</sub> @ I <sub>T</sub> (min) <sup>(1)</sup>		V <sub>C</sub> @ I <sub>PP</sub> (max) 10/1000µs		V <sub>C</sub> @ I <sub>PP</sub> (max) 8/20µs		Max. Temp. Coefficient of V <sub>(BR)</sub> <sup>(2)</sup>	Typical Capacitance C <sup>(3)</sup>
		µA	V	V	mA	V	A	V	A		
Unidirectional	Bidirectional									%/C	pF
BZW06-5V8	BZW06-5V8B	1000	5.80	6.45	10	10.5	57.0	13.4	298	0.057	4000
BZW06-6V4	BZW06-6V4B	500	6.40	7.13	10	11.3	53.0	14.5	276	0.061	3700
BZW06-8V5	BZW06-8V5B	10	8.50	9.50	1	14.5	41.0	18.6	215	0.073	2800
BZW06-10	BZW06-10B	5	10.2	11.4	1	16.7	36.0	21.7	184	0.078	2300
BZW06-13	BZW06-13B	5	12.8	14.3	1	21.2	28.0	27.2	147	0.084	1900
BZW06-15	BZW06-15B	1	15.3	17.1	1	25.2	24.0	32.5	123	0.088	1600
BZW06-19	BZW06-19B	1	18.8	20.9	1	30.6	19.6	39.3	102	0.092	1350
BZW06-20	BZW06-20B	1	20.5	22.8	1	33.2	18.0	42.8	93.0	0.094	1250
BZW06-23	BZW06-23B	1	23.1	25.7	1	37.5	16.0	48.3	83.0	0.096	1150
BZW06-26	BZW06-26B	1	25.6	28.5	1	41.5	14.5	53.5	75.0	0.097	1075
BZW06-28	BZW06-28B	1	28.2	31.4	1	45.7	13.1	59.0	68.0	0.098	1000
BZW06-31	BZW06-31B	1	30.8	34.2	1	49.9	12.0	64.3	62.0	0.099	950
BZW06-33	BZW06-33B	1	33.3	37.1	1	53.9	11.1	69.7	57.0	0.100	900
BZW06-40	BZW06-40B	1	40.2	44.7	1	64.8	9.3	84.0	48.0	0.101	800
BZW06-48	BZW06-48B	1	47.8	53.2	1	77.0	6.5	100	40.0	0.103	700
BZW06-58	BZW06-58B	1	58.1	64.6	1	92.0	5.4	121	33.0	0.104	625
BZW06-70	BZW06-70B	1	70.1	77.9	1	113	4.4	146	27.0	0.105	550
BZW06-85	BZW06-85B	1	85.5	95.0	1	137	3.6	178	22.5	0.106	500
BZW06-102	BZW06-102B	1	102	114	1	165	3.0	212	19.0	0.107	450
BZW06-128	BZW06-128B	1	128	143	1	207	2.4	265	15.0	0.108	400
BZW06-154	BZW06-154B	1	154	171	1	246	2.0	317	12.6	0.108	360
BZW06-171	BZW06-171B	1	171	190	1	274	1.8	353	11.3	0.108	350
BZW06-188	BZW06-188B	1	188	209	1	328	1.5	388	10.3	0.108	330
BZW06-213	BZW06-213B	1	213	237	1	344	1.7	442	9.0	0.110	310
BZW06-256	BZW06-256B	1	256	285	1	414	1.4	529	7.6	0.110	290
BZW06-273	BZW06-273B	1	273	304	1	438	1.4	564	7.1	0.110	280
BZW06-299	BZW06-299B	1	299	332	1	482	1.2	618	6.5	0.110	270
BZW06-342	BZW06-342B	1	342	380	1	548	1.1	706	5.7	0.110	360
BZW06-376	BZW06-376B	1	376	418	1	603	1.0	776	5.7	0.100	350

NOTE: (1) Pulse test: tp 50ms.

www.galaxycn.com

(2)  $\Delta V_{(BR)} = \alpha T^* (T_A - 25) * V_{(BR)} (25^\circ C)$

(3) V<sub>R</sub> = 0 V, f = 1 MHz. For Bidirectional types, capacitance value is divided by 2

**FIG.1 – PEAK PULSE POWER RATING CURVE**

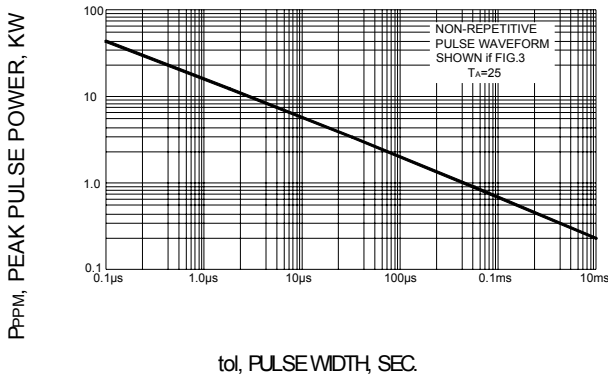

**FIG.2 – PULSE DERATING CURVE**

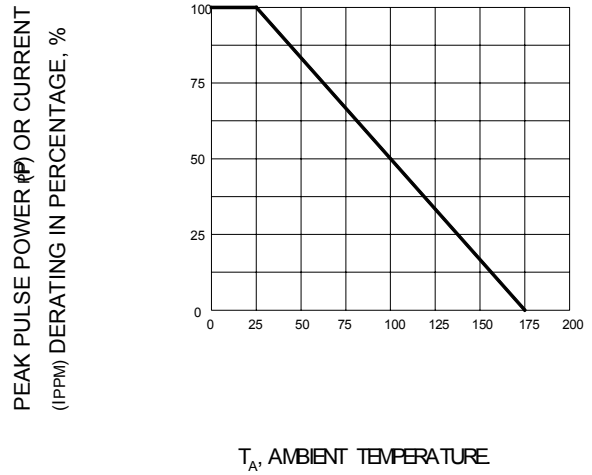

**FIG.3 – PULSE WAVEFORM**

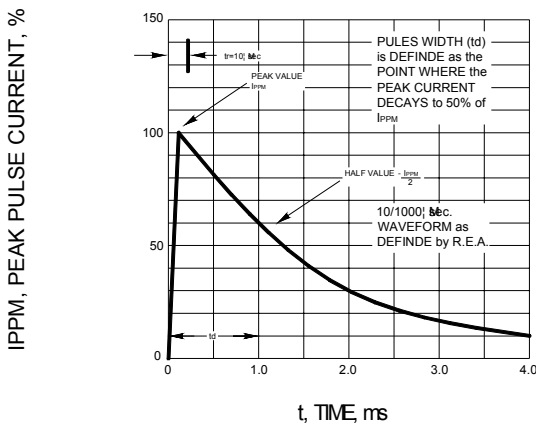

**FIG.4 – TYPICAL JUNCTION CAPACITANCE UNIDIRECTIONAL**

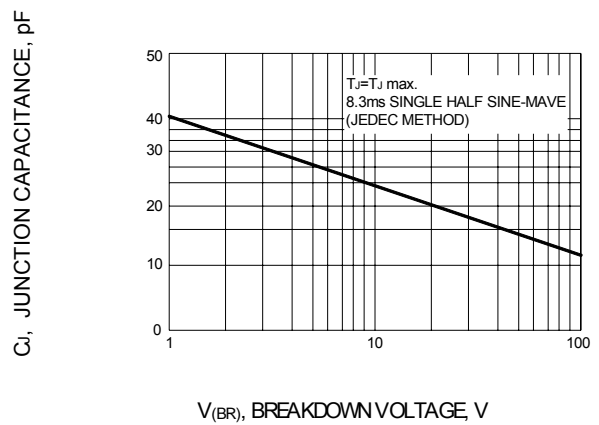

**FIG.5 – STEADY STATE POWER DERATING CURVE**

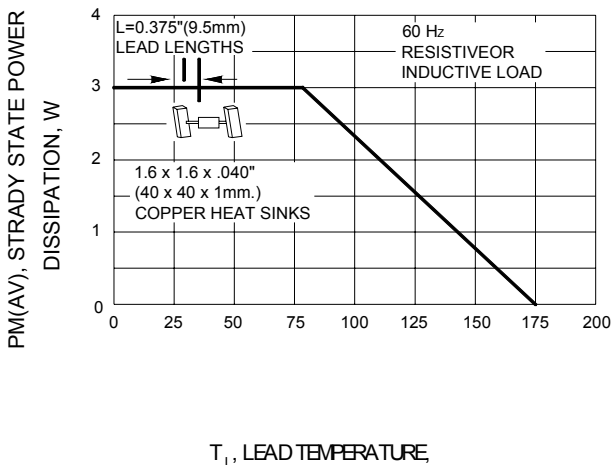

**FIG.6 – MAXIMUM NON-REPETITIVE FORWARD SURGE CURRENT UNIDIRECTIONAL ONLY**

