

HEDS-97EX Series

Small Optical Encoder Modules

200 LPI Analog Voltage Output



Data Sheet

Description

The HEDS-97EX series is a small and high performance optical incremental encoder module. When operated in conjunction with either a codewheel or codestrip, this module detects rotary or linear position. The encoder module consists of a lensed LED source and a detector IC enclosed in a small C-shaped plastic package. Due to a highly collimated light source and a unique photodetector array, the module is extremely tolerant to mounting misalignment.

The two channel analog outputs and 3.3V supply input are accessed through four solder-plated leads located on 2.54 mm (0.1 inch.) centers.

HEDS-97EX is designed for use with an appropriate optical radius codewheel. Please contact factory for more information.

Features

- Small size
- Multiple mounting options
- Insensitive to radial and axial play
- 0°C to +60°C recommended operating temperature
- Two channel analog output
- Single 3.3V supply
- Wave solderable
- RoHS compliant

Specifications

- 200 LPI
 - 3.3V supply*
- * Typical conditions

Applications

- Printers
- Copiers/Fax
- Plotters
- Office automation equipments

ESD WARNING: NORMAL PRECAUTIONS SHOULD BE TAKEN TO AVOID STATIC DISCHARGE.

Theory of Operation

The HEDS-97EX is a C-shaped emitter/detector module. Coupled with a codewheel/codestrip, it translates rotary motion into a two-channel analog output.

The module contains a single Light Emitting Diode (LED) as its light source. The light is collimated into a parallel beam by means of a single lens located directly over the LED. Opposite the emitter is the integrated detector circuit. This IC consists of multiple sets of photodetectors and the signal processing circuitry necessary to produce the analog waveforms.

The codewheel/codestrip moves between the emitter and detector, causing the light beam to be interrupted by the pattern of spaces and bars on the codewheel/codestrip.

The photodiodes, which detect these interruptions, are arranged in a pattern that corresponds to the radius and count density of the codewheel/codestrip.

These detectors are also spaced such that a light period on one pair of detectors corresponds to a dark period on the adjacent pairs of detectors. The photodiode outputs are fed through the signal processing circuitry, which produce the final outputs for Channel A and Channel B. Due to this integrated phasing technique, the analog output of Channel A is in quadrature with Channel B (90 degrees out of phase).

Definitions

Count (N): The number of bar and window pairs or counts per revolution (CPR) of the codewheel. Or the number of lines per inch of the codestrip (LPI)

1 shaft rotation = 360 degrees
= N cycles

1 cycle (c) = 360 electrical degree, equivalent to 1 bar and window pair.

Direction of Rotation: When the codewheel rotates in the counter-clockwise direction (as viewed from the encoder end of the motor), channel A will lead channel B. If the codewheel rotates in the clockwise direction, channel B will lead channel A.

Line Density: The number of window and bar pair per unit length, express in either lines per inch (LPI) or lines per mm (LPmm)

Optical Radius (R_{op}): The distance from the codewheel's center of rotation to the optical center (O.C) of the encoder module.

Gap (G): The distance from surface of the encoder to the surface of codewheel or codestrip

Mounting Position (R_M): Distance from Motor Shaft center of rotation to center of Alignment Tab receiving hole.

Radial and Tangential Misalignment Error (E_R and E_T): For rotary motion mechanical displacement in the radial and tangential directions relative to the nominal alignment

Angular Misalignment Error (E_A): Angular misalignment of the sensor in relation to then tangential direction. This applies for both rotary and linear motion.of electrical degrees that an output is high during one cycle, nominally 180°e or 1/2 a cycle.

Absolute Maximum Ratings

Subjecting the part to stresses beyond those listed under this section may cause permanent damage to the device. These are stress ratings only and do not imply that the device functions beyond these ratings. Exposure to the extremes of these conditions for extended periods may affect device reliability.

Parameter	Symbol	Min.	Max.	Units	Notes
Storage Temperature	T_S	-40	85	°C	
Operating Temperature	T_A	0	60	°C	
Supply voltage (Detector)	V_{CC}	-0.5	7	V	
Output Voltage	V_a, V_b	-0.5	$V_{CC} + 0.4$	V	
Soldering Temperature			260	°C	$t \leq 7$ sec
DC Forward current (LED)	I_{LED}		50	mA	$V_F < 1.8V$
Reverse Voltage	V_R		5	V	$I_R = 100\mu A$

Recommended Operating Conditions

Parameter	Symbol	Min.	Typ.	Max.	Units	Notes
Operating Temperature	T	0	25	60	°C	
Supply Voltage (Detector)	V_{CC}	3.15	3.3	3.45	V	Ripple < 100mVpp
Output Frequency	f		8	40	KHz	(Velocity (rpm) x N)/60
DC Forward Current (LED)	I_{LED}		26		mA	

Electrical Characteristics

Electrical Characteristics over Recommended Operating Range, typically at 25°C

Parameter	Symbol	Min.	Typ.	Max.	Units	Notes
Supply Current (Detector)	I_{CC}		5	8	mA	
LED Forward Voltage	V_F	1.3 (turn on) 1.5 (operate)	1.44	1.54	V	Typical $I_f = 24mA$

Encoding Characteristics

Parameter	Symbol	Min (b)	Max (b)	Units
State width error	ΔS	-40	+40	°e
Pulse width error	ΔP	-40	+40	°e
Peak to Peak voltage	V_{ppA} V_{ppB}	1	3	V
Analog offset voltage	$V_{offset A}$ $V_{offset B}$	-150	150	mV

Notes:

(a) Obtained at typical conditions specified in "Recommended Operating Conditions" and nominal mounting position (Radial, Tangential, Gap) of (0,0,0)

(b) Obtained over the whole "Recommended Operating Conditions" and "Part Mounting Tolerances"

Waveform Definition

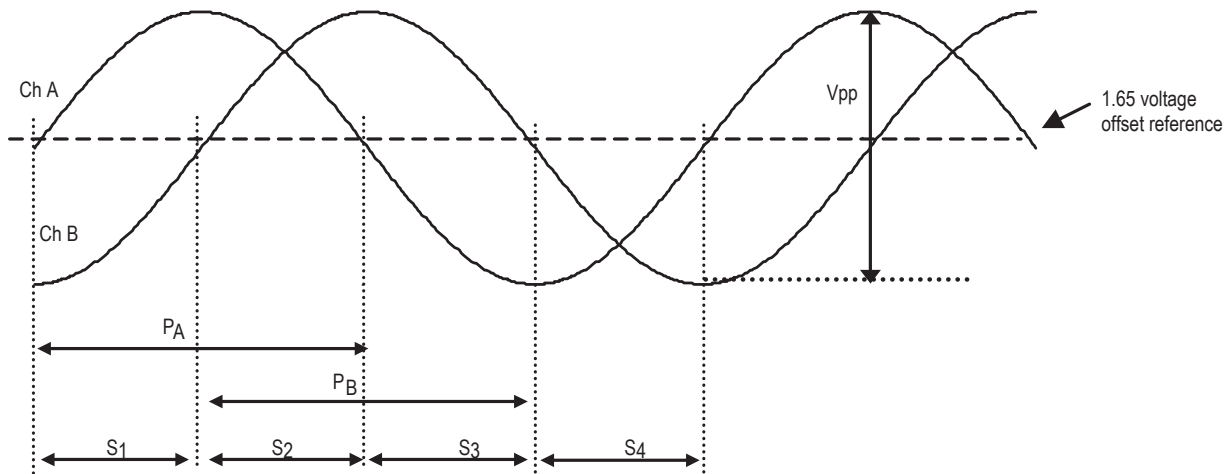

Test Parameter Definitions

Parameter	Symbol	Definition	Units
Analog peak voltage	$V_{ap}, V_{bp}, V_{am}, V_{bm}$	The absolute value in V of the magnitude of the analog signal (i.e. one sided rating)	V
Analog peak to peak voltage	V_{pp}	The peak to peak signal magnitude in μA of the analog signal	V
Analog peak to peak ratio	V_{ppA}/V_{ppB}	The ratio of A channel peak analog signal to B channel peak analog signal	V
Analog Crossing	$V_{x12}, V_{x34}, V_{x56}, V_{x78}$	The intersection in V of the A channel analog waveform with either the B channel analog waveform or its compliment.	V
Analog Offset current	V_{offset}	The offset in V from the mid-point of the analog peak to peak signal to zero current	V
State Width	S_1, S_2, S_3, S_4	The number of electrical degrees between a transition in channel A and the neighboring transition in channel B. There are 4 state per cycle, each nominally $90^\circ e$. The transitions are determined by where the analog signal crosses the Zero point	$^\circ e$
State Width Error	$\Delta S_1, \Delta S_2, \Delta S_3, \Delta S_4$	The deviation in electrical degrees of each state width from its ideal value of $90^\circ e$.	$^\circ e$
Pulse Width	P_A, P_B	The number of electrical degrees that an analog output is greater than zero during one cycle. This value is nominally $180^\circ e$ or $\frac{1}{2}$ cycle.	$^\circ e$
Pulse Width Error	ΔP	The deviation in electrical degrees of each pulse width from its ideal value of $180^\circ e$.	$^\circ e$

Mounting Configuration

Error		Rop=19.40mm	Unit	Notes
Eg	Gap	0.05 to 0.65	mm	Recommend CW to put closer to the detector side (upper side), in order to give enough margin for encoder operation.
Er	Radial	±0.13	mm	
Et	Tangential	±0.13	mm	
Ea	Angular	±3	Deg.	

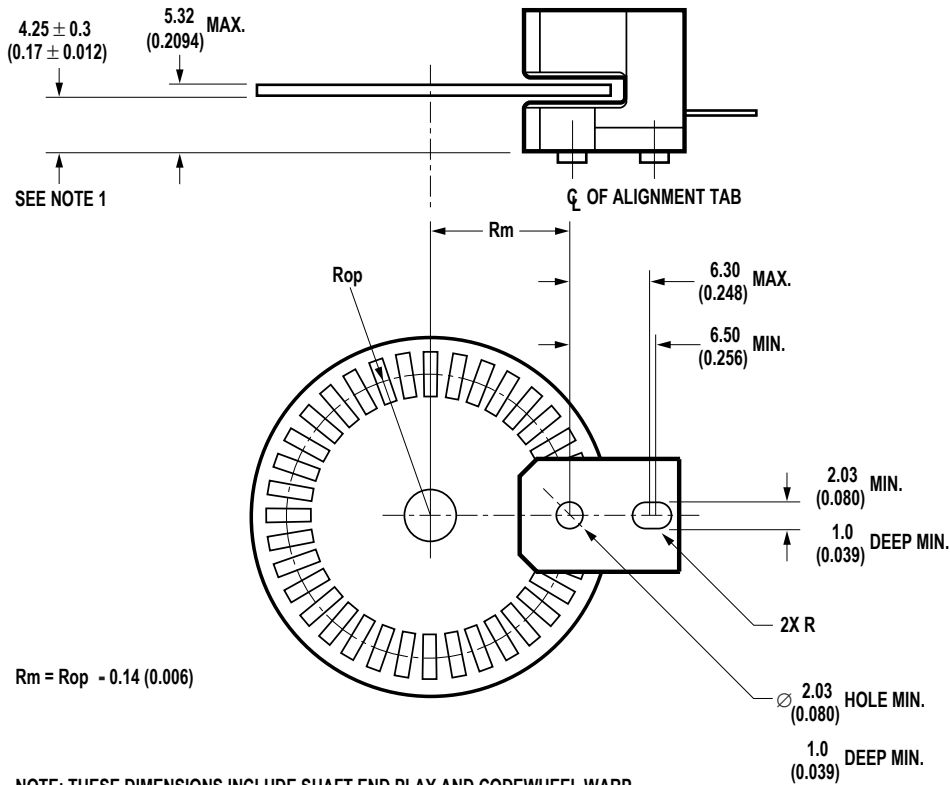

NOTE: THESE DIMENSIONS INCLUDE SHAFT END PLAY AND CODEWHEEL WARP.

ALL DIMENSIONS FOR MOUNTING THE MODULE/CODESTRIP SHOULD BE MEASURED WITH RESPECT TO THE TWO MOUNTING POSTS, SHOWN ABOVE.

DIMENSIONS IN MILLIMETERS (INCHES).

Recommended Codewheel and Codestrip Characteristics

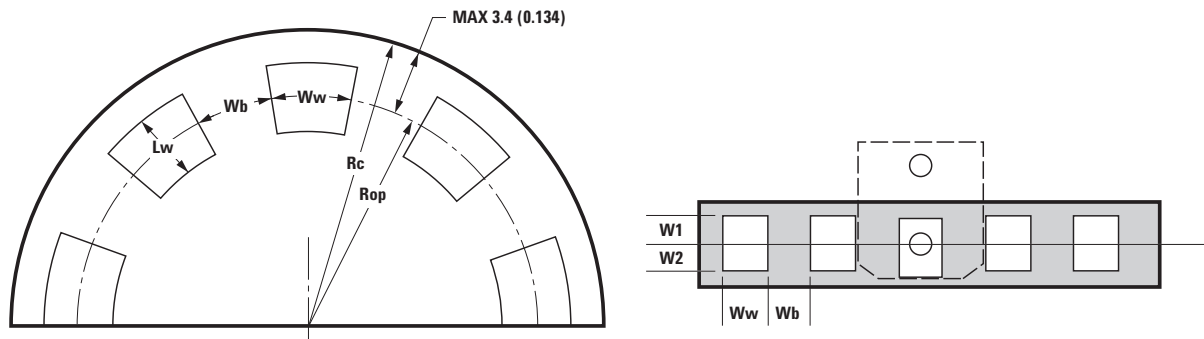

Parameter	Symbol	Min.	Max.	Units	Notes
Window/Bar Ratio	W_w/W_b	0.9	1.1		
Window Length (Rotary)	L_w	1.80 (0.071)	3.0 (0.1181)	mm (inch)	
Absolute Maximum Codewheel Radius (Rotary)	R_c		$R_{op} + 3.40$ ($R_{op} + 0.134$)	mm (inch)	Includes eccentricity errors
Center of Post to Inside Edge of Window	W_1	1.04 (0.041)		mm (inch)	
Center of Post to Outside Edge of Window	W_2	0.76 (0.030)		mm (inch)	
Center of Post to Inside Edge of Codestrip	L		3.60 (0.142)	mm (inch)	

HEDS-97E0-R54 (Bracket 54)

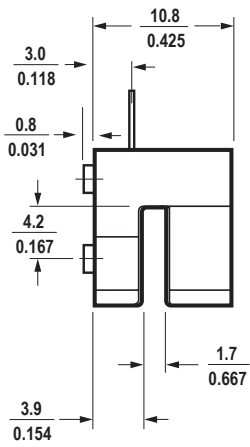
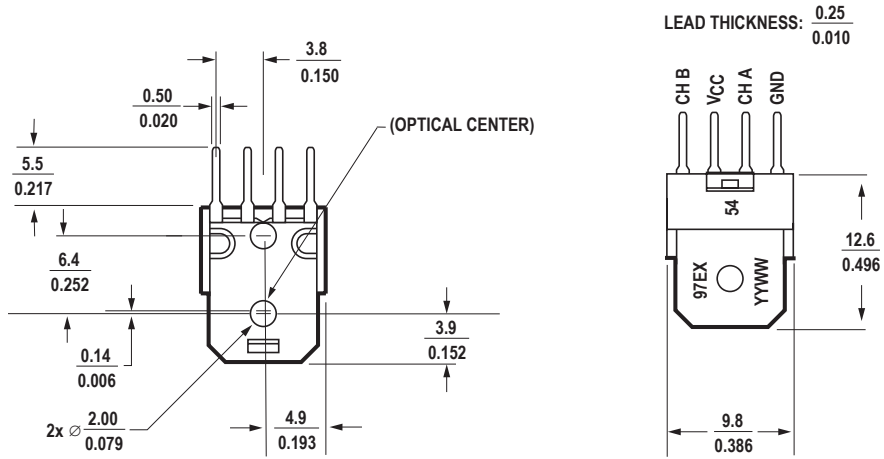

HEDS-97E1-R54 (BEND LEAD)

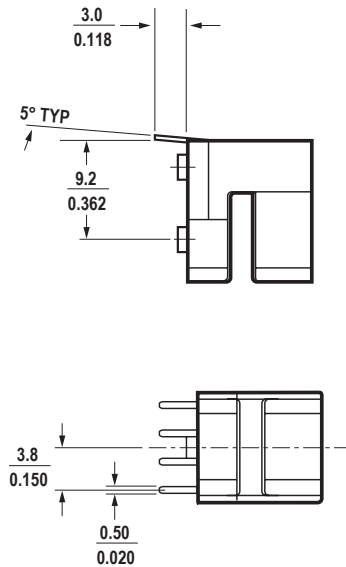

Recommended Wave Solder Profile

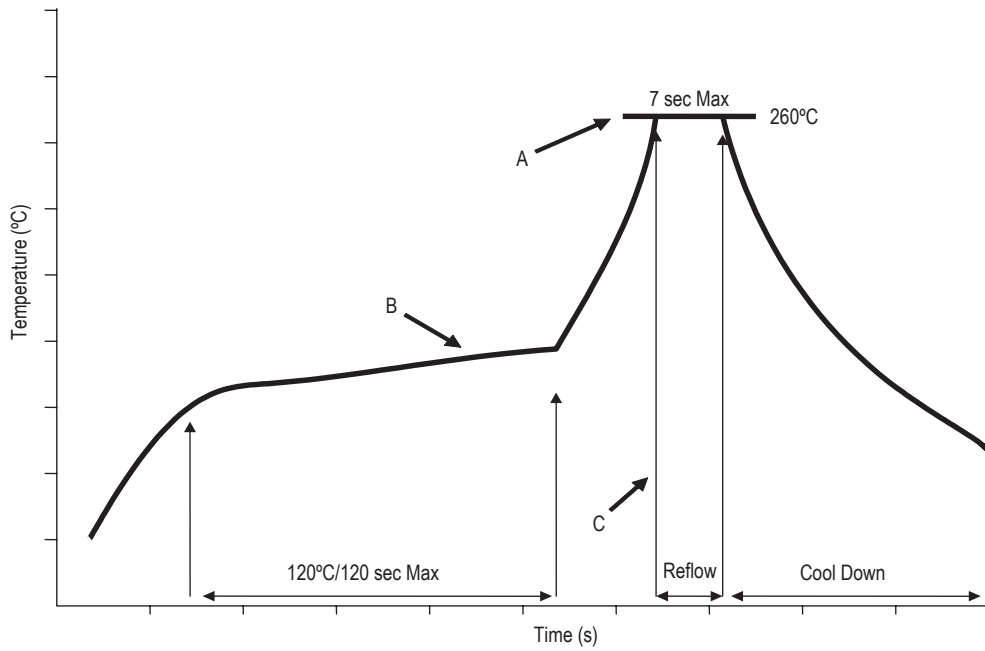

Parameter	Min.	Max.	Nominal values	Units
A Solder Pot Temperature	NA	260	250 - 260	°C
B Preheat Zone Temperature	85	120	100 - 120	°C
C Dip in Time	5	7	5	sec
D Solder Pot Zone (Encoder Lead)	200	260	NA	°C

Note:

- Nominal values are evaluated profiles for optimum performance.
- Min/Max are critical limits to ensure encoders in good condition.

Ordering Information

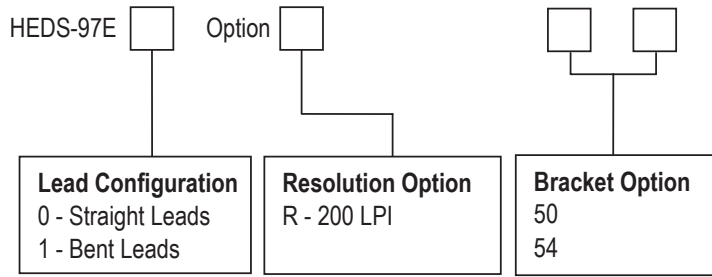

For product information and a complete list of distributors, please go to our web site: www.avagotech.com

Avago, Avago Technologies, and the A logo are trademarks of Avago Technologies, Limited in the United States and other countries. Data subject to change. Copyright © 2006 Avago Technologies Limited. All rights reserved.
AV02-0184EN - March 28, 2007

AVAGO
TECHNOLOGIES