

To all our customers

Regarding the change of names mentioned in the document, such as Hitachi Electric and Hitachi XX, to Renesas Technology Corp.

The semiconductor operations of Mitsubishi Electric and Hitachi were transferred to Renesas Technology Corporation on April 1st 2003. These operations include microcomputer, logic, analog and discrete devices, and memory chips other than DRAMs (flash memory, SRAMs etc.) Accordingly, although Hitachi, Hitachi, Ltd., Hitachi Semiconductors, and other Hitachi brand names are mentioned in the document, these names have in fact all been changed to Renesas Technology Corp. Thank you for your understanding. Except for our corporate trademark, logo and corporate statement, no changes whatsoever have been made to the contents of the document, and these changes do not constitute any alteration to the contents of the document itself.

Renesas Technology Home Page: <http://www.renesas.com>

Renesas Technology Corp.
Customer Support Dept.
April 1, 2003

Cautions

Keep safety first in your circuit designs!

1. Renesas Technology Corporation puts the maximum effort into making semiconductor products better and more reliable, but there is always the possibility that trouble may occur with them. Trouble with semiconductors may lead to personal injury, fire or property damage.

Remember to give due consideration to safety when making your circuit designs, with appropriate measures such as (i) placement of substitutive, auxiliary circuits, (ii) use of nonflammable material or (iii) prevention against any malfunction or mishap.

Notes regarding these materials

1. These materials are intended as a reference to assist our customers in the selection of the Renesas Technology Corporation product best suited to the customer's application; they do not convey any license under any intellectual property rights, or any other rights, belonging to Renesas Technology Corporation or a third party.
2. Renesas Technology Corporation assumes no responsibility for any damage, or infringement of any third-party's rights, originating in the use of any product data, diagrams, charts, programs, algorithms, or circuit application examples contained in these materials.
3. All information contained in these materials, including product data, diagrams, charts, programs and algorithms represents information on products at the time of publication of these materials, and are subject to change by Renesas Technology Corporation without notice due to product improvements or other reasons. It is therefore recommended that customers contact Renesas Technology Corporation or an authorized Renesas Technology Corporation product distributor for the latest product information before purchasing a product listed herein.
The information described here may contain technical inaccuracies or typographical errors. Renesas Technology Corporation assumes no responsibility for any damage, liability, or other loss rising from these inaccuracies or errors.
Please also pay attention to information published by Renesas Technology Corporation by various means, including the Renesas Technology Corporation Semiconductor home page (<http://www.renesas.com>).
4. When using any or all of the information contained in these materials, including product data, diagrams, charts, programs, and algorithms, please be sure to evaluate all information as a total system before making a final decision on the applicability of the information and products. Renesas Technology Corporation assumes no responsibility for any damage, liability or other loss resulting from the information contained herein.
5. Renesas Technology Corporation semiconductors are not designed or manufactured for use in a device or system that is used under circumstances in which human life is potentially at stake. Please contact Renesas Technology Corporation or an authorized Renesas Technology Corporation product distributor when considering the use of a product contained herein for any specific purposes, such as apparatus or systems for transportation, vehicular, medical, aerospace, nuclear, or undersea repeater use.
6. The prior written approval of Renesas Technology Corporation is necessary to reprint or reproduce in whole or in part these materials.
7. If these products or technologies are subject to the Japanese export control restrictions, they must be exported under a license from the Japanese government and cannot be imported into a country other than the approved destination.
Any diversion or reexport contrary to the export control laws and regulations of Japan and/or the country of destination is prohibited.
8. Please contact Renesas Technology Corporation for further details on these materials or the products contained therein.

HD404358 Series



Rev. 6.0
Sept. 1998

Description

The HD404358 Series is a 4-bit HMCS400-Series microcomputer designed to increase program productivity and also incorporate large-capacity memory. Each microcomputer has an A/D converter, input capture timer, and two low-power dissipation modes.

The HD404358 Series includes seven chips: the HD404354, HD40A4354 with 4-kword ROM; the HD404356, HD40A4356 with 6-kword ROM; the HD404358, HD40A4358 with 8-kword ROM; the HD407A4359 with 16-kword PROM.

The HD40A4354, HD40A4356, HA40A4358, and HD407A4359 are high speed versions (minimum instruction cycle time: 0.47 μ s)

The HD407A4359 is a PROM version (ZTATTM microcomputer). A program can be written to the PROM by a PROM writer, which can dramatically shorten system development periods and smooth the process from debugging to mass production. (The ZTATTM version is 27256-compatible.)

ZTATTM: Zero Turn Around Time ZTAT is a trademark of Hitachi Ltd.

Features

- 34 I/O pins
 - One input-only pin
 - 33 input/output pins: 4 pins are intermediate-voltage NMOS open drain with high-current pins (15 mA, max.)
- On-chip A/D converter (8-bit \times 8-channel)
 - Low power voltage 2.7 V to 6.0 V
- Three timers
 - One event counter input
 - One timer output
 - One input capture timer
- Eight-bit clock-synchronous serial interface (1 channel)
- Alarm output

HD404358 Series

- Built-in oscillators
 - Ceramic oscillator or crystal
 - External clock drive is also possible
- Seven interrupt sources
 - Two by external sources
 - Three by timers
 - One by A/D converter
 - One by serial interface
- Two low-power dissipation modes
 - Standby mode
 - Stop mode
- Instruction cycle time
 - 0.47 μ s ($f_{OSC} = 8.5$ MHz, 1/4 division ratio):
HD40A4354, HD40A4356, HD40A4358,
HD407A4359
 - 0.8 μ s ($f_{OSC} = 5$ MHz, 1/4 division ratio):
HD404354, HD404356, HD404358

Ordering Information

Type	Instruction Cycle Time	Product Name	Model Name	ROM (Words)	RAM (Digit)	Package
Mask ROM	Standard versions ($f_{OSC} = 5$ MHz)	HD404354	HD404354S	4,096	384	DP-42S
			HD404354H			FP-44A
		HD404356	HD404356S	6,144	DP-42S	
			HD404356H		FP-44A	
		HD404358	HD404358S	8,192	DP-42S	
	HD404358H		FP-44A			
	High speed versions ($f_{OSC} = 8.5$ MHz)	HD40A4354	HD40A4354S	4,096	384	DP-42S
			HD40A4354H			FP-44A
		HD40A4356	HD40A4356S	6,144	DP-42S	
			HD40A4356H		FP-44A	
HD40A4358		HD40A4358S	8,192	DP-42S		
		HD40A4358H		FP-44A		
ZTAT™	($f_{OSC} = 8.5$ MHz)	HD407A4359	HD407A4359S	16,384	512	DP-42S
			HD407A4359H			FP-44A

Pin Arrangement

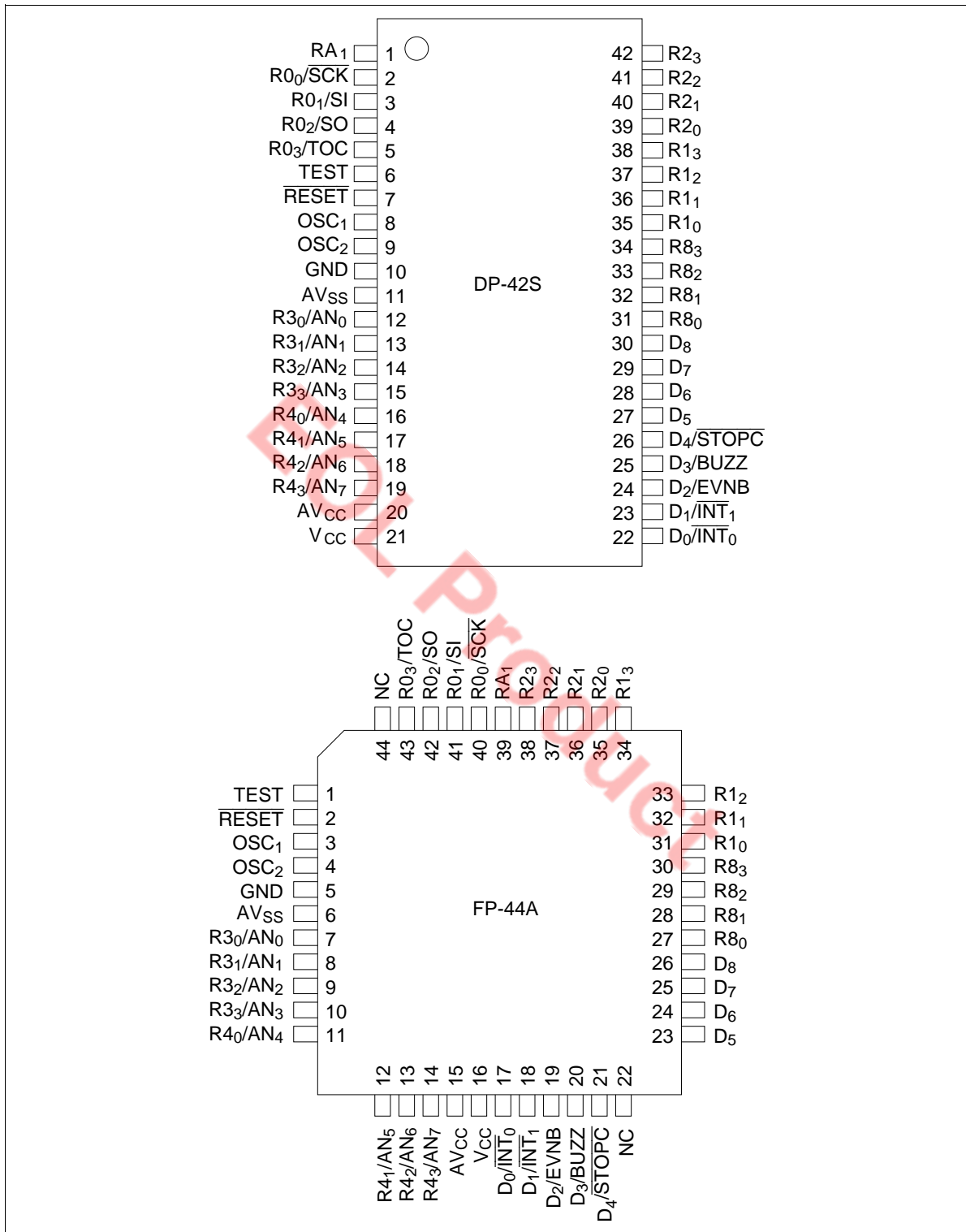

HD404358 Series

Pin Description

Item	Symbol	Pin Number		I/O	Function
		DP-42S	FP-44A		
Power supply	V_{CC}	21	16		Applies power voltage
	GND	10	5		Connected to ground
Test	TEST	6	1	I	Cannot be used in user applications. Connect this pin to GND.
Reset	$\overline{\text{RESET}}$	7	2	I	Resets the MCU
Oscillator	OSC_1	8	3	I	Input/output pin for the internal oscillator. Connect these pins to the ceramic oscillator or crystal oscillator, or OSC_1 to an external oscillator circuit.
	OSC_2	9	4	O	
Port	$D_0\text{--}D_8$	22–30	17–21, 23–26	I/O	Input/output pins addressed individually by bits; $D_0\text{--}D_8$ are all standard-voltage I/O pins.
	RA_1	1	39	I	One-bit standard-voltage input port pin
	$R0_0\text{--}R1_3$,	2–5,	40–43,	I/O	Four-bit input/output pins consisting of standard-voltage pins
	$R3_0\text{--}R4_3$,	12–19,	7–14		
	$R8_0\text{--}R8_3$	31–38	27–34		
$R2_0\text{--}R2_3$	39–42	35–38	I/O	Four-bit input/output pins consisting of intermediate voltage pins	
Interrupt	$\overline{\text{INT}}_0, \overline{\text{INT}}_1$	22, 23	17, 18	I	Input pins for external interrupts
Stop clear	$\overline{\text{STOPC}}$	26	21	I	Input pin for transition from stop mode to active mode
Serial Interface	$\overline{\text{SCK}}$	2	40	I/O	Serial interface clock input/output pin
	SI	3	41	I	Serial interface receive data input pin
	SO	4	42	O	Serial interface transmit data output pin
Timer	TOC	5	43	O	Timer output pin
	EVNB	24	19	I	Event count input pin
Alarm	BUZZ	25	20	O	Square waveform output pin
A/D converter	AV_{CC}	20	15		Power supply for the A/D converter. Connect this pin as close as possible to the V_{CC} pin and at the same voltage as V_{CC} . If the power supply voltage to be used for the A/D converter is not equal to V_{CC} , connect a 0.1- μF bypass capacitor between the AV_{CC} and AV_{SS} pins. (However, this is not necessary when the AV_{CC} pin is directly connected to the V_{CC} pin.)
	AV_{SS}	11	6		Ground for the A/D converter. Connect this pin as close as possible to GND at the same voltage as GND.
	$AN_0\text{--}AN_7$	12–19	7–14	I	Analog input pins for the A/D converter

Block Diagram

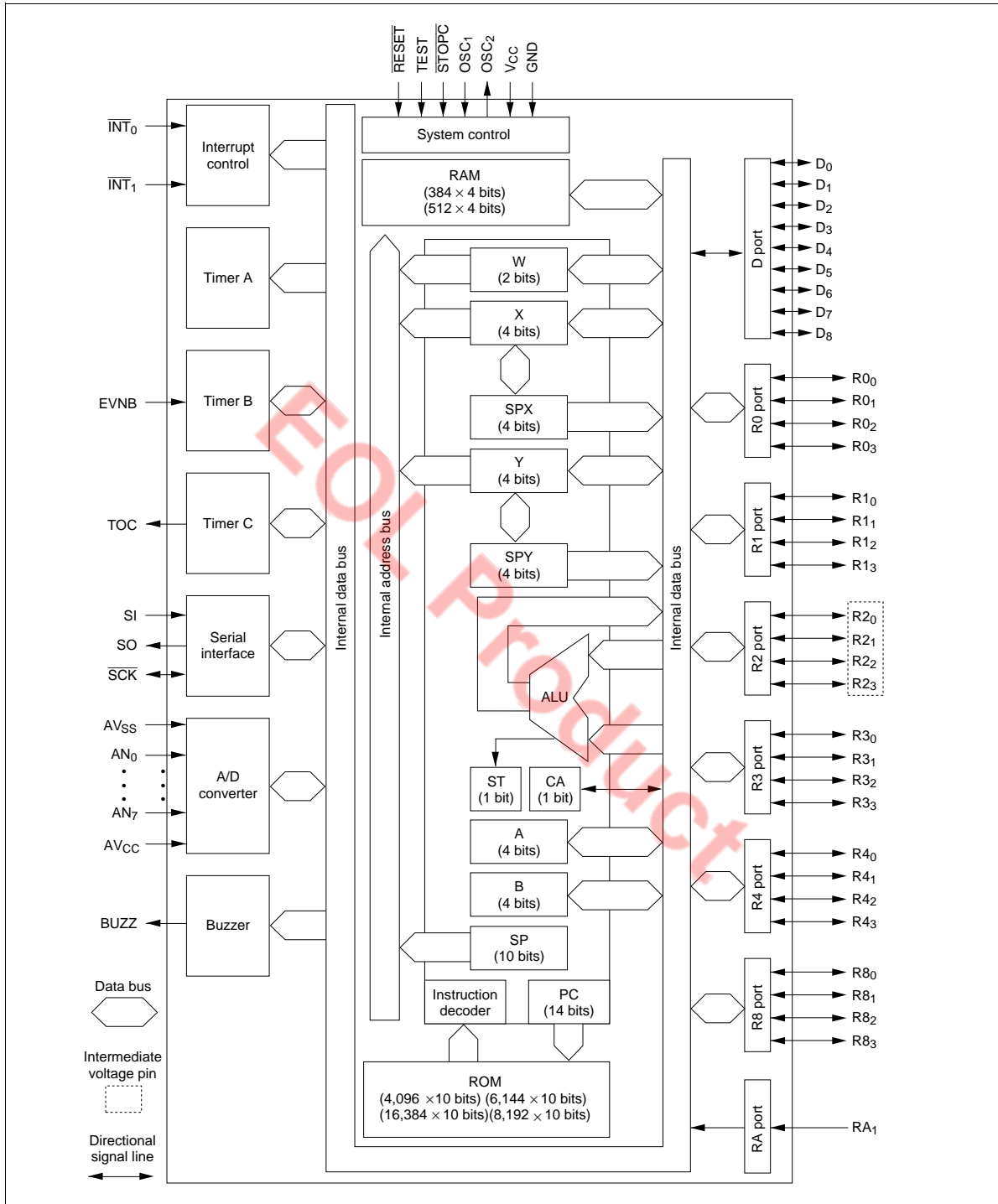

HD404358 Series

Memory Map

ROM Memory Map

The ROM memory map is shown in figure 1 and described below.

Vector Address Area (\$0000–\$000F): Reserved for JMPL instructions that branch to the start addresses of the reset and interrupt routines. After MCU reset or an interrupt, program execution continues from the vector address.

Zero-Page Subroutine Area (\$0000–\$003F): Reserved for subroutines. The program branches to a subroutine in this area in response to the CAL instruction.

Pattern Area (\$0000–\$0FFF): Contains ROM data that can be referenced with the P instruction.

Program Area (\$0000–\$0FFF (HD404354, HD40A4354), \$0000–\$17FF (HD404356, HD40A4356), \$0000–\$1FFF (HD404358, HD40A4358), \$0000–\$3FFF (HD407A4359)): The entire ROM area can be used for program coding.

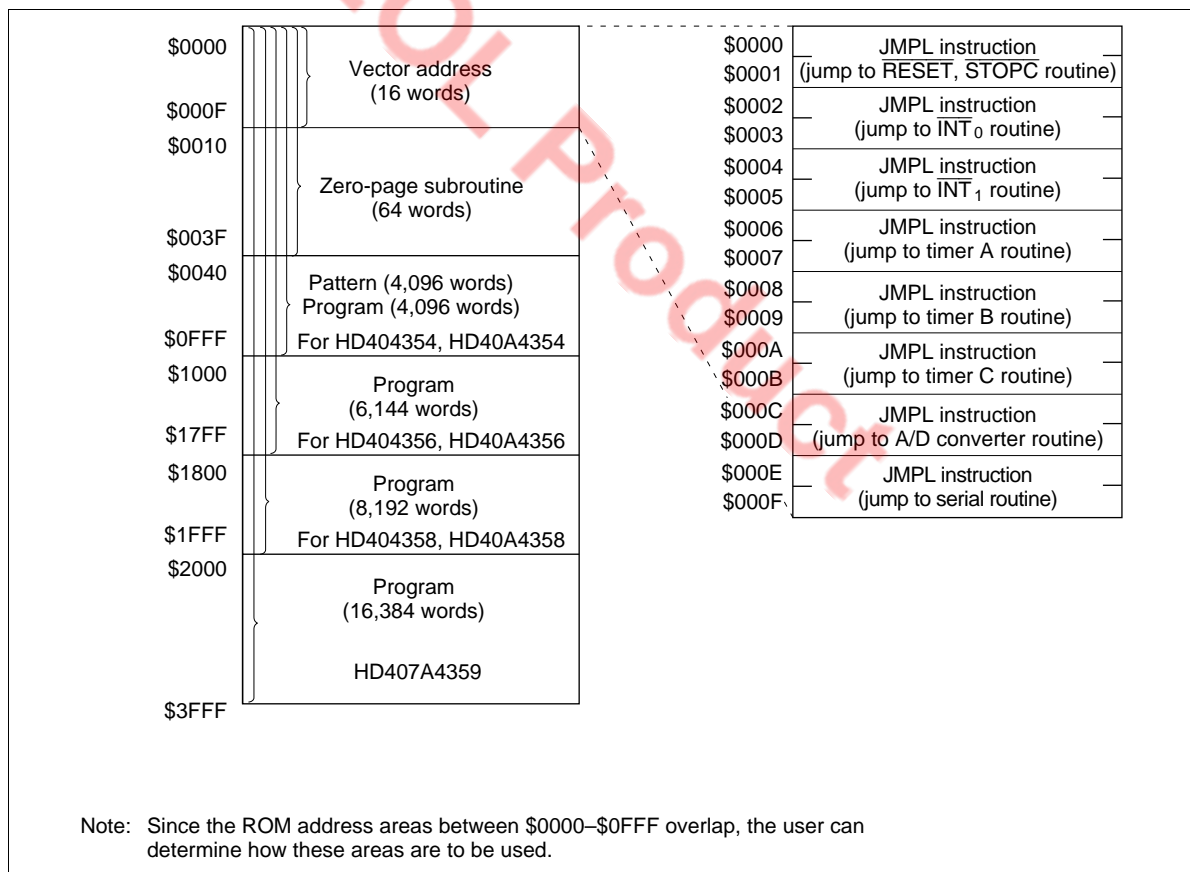

Figure 1 ROM Memory Map

RAM Memory Map

The HD404354, HD40A4354, HD404356, HD40A4356, HD404358 and HD40A4358 MCUs contain 384-digit × 4-bit RAM areas. The HD407A4359 MCU contain 512-digit × 4-bit RAM areas. Both of these RAM areas consist of a memory register area, a data area, and a stack area. In addition, an interrupt control bits area, special function register area, and register flag area are mapped onto the same RAM memory space labeled as a RAM-mapped register area. The RAM memory map is shown in figure 2 and described below.

RAM-Mapped Register Area (\$000–\$03F):

- **Interrupt Control Bits Area (\$000–\$003)**
This area is used for interrupt control bits (figure 3). These bits can be accessed only by RAM bit manipulation instructions (SEM/ SEMD, REM/REMD, and TM/TMD). However, note that not all the instructions can be used for each bit. Limitations on using the instructions are shown in figure 4.
- **Special Function Register Area (\$004–\$01F, \$024–\$03F)**
This area is used as mode registers and data registers for external interrupts, serial interface, timer/counters, A/D converter, and as data control registers for I/O ports. The structure is shown in figures 2 and 5. These registers can be classified into three types: write-only (W), read-only (R), and read/write (R/W). RAM bit manipulation instructions cannot be used for these registers.
- **Register Flag Area (\$020–\$023)**
This area is used for the DTON, WDON, and other register flags and interrupt control bits (figure 3). These bits can be accessed only by RAM bit manipulation instructions (SEM/ SEMD, REM/REMD, and TM/TMD). However, note that not all the instructions can be used for each bit. Limitations on using the instructions are shown in figure 4.

Memory Register (MR) Area (\$040–\$04F): Consisting of 16 addresses, this area (MR0–MR15) can be accessed by register-register instructions (LAMR and XMRA). The structure is shown in figure 6.

Data Area (\$050–\$17F for HD404354/HD40A4354/HD404356/HD40A4356/HD404358/HD40A4358, \$050–\$1FF for HD407A4359)

Stack Area (\$3C0–\$3FF): Used for saving the contents of the program counter (PC), status flag (ST), and carry flag (CA) at subroutine call (CAL or CALL instruction) and for interrupts. This area can be used as a 16-level nesting subroutine stack in which one level requires four digits. The data to be saved and the save conditions are shown in figure 6.

The program counter is restored by either the RTN or RTNI instruction, but the status and carry flags can only be restored by the RTNI instruction. Any unused space in this area is used for data storage.

HD404358 Series

RAM Memory Map

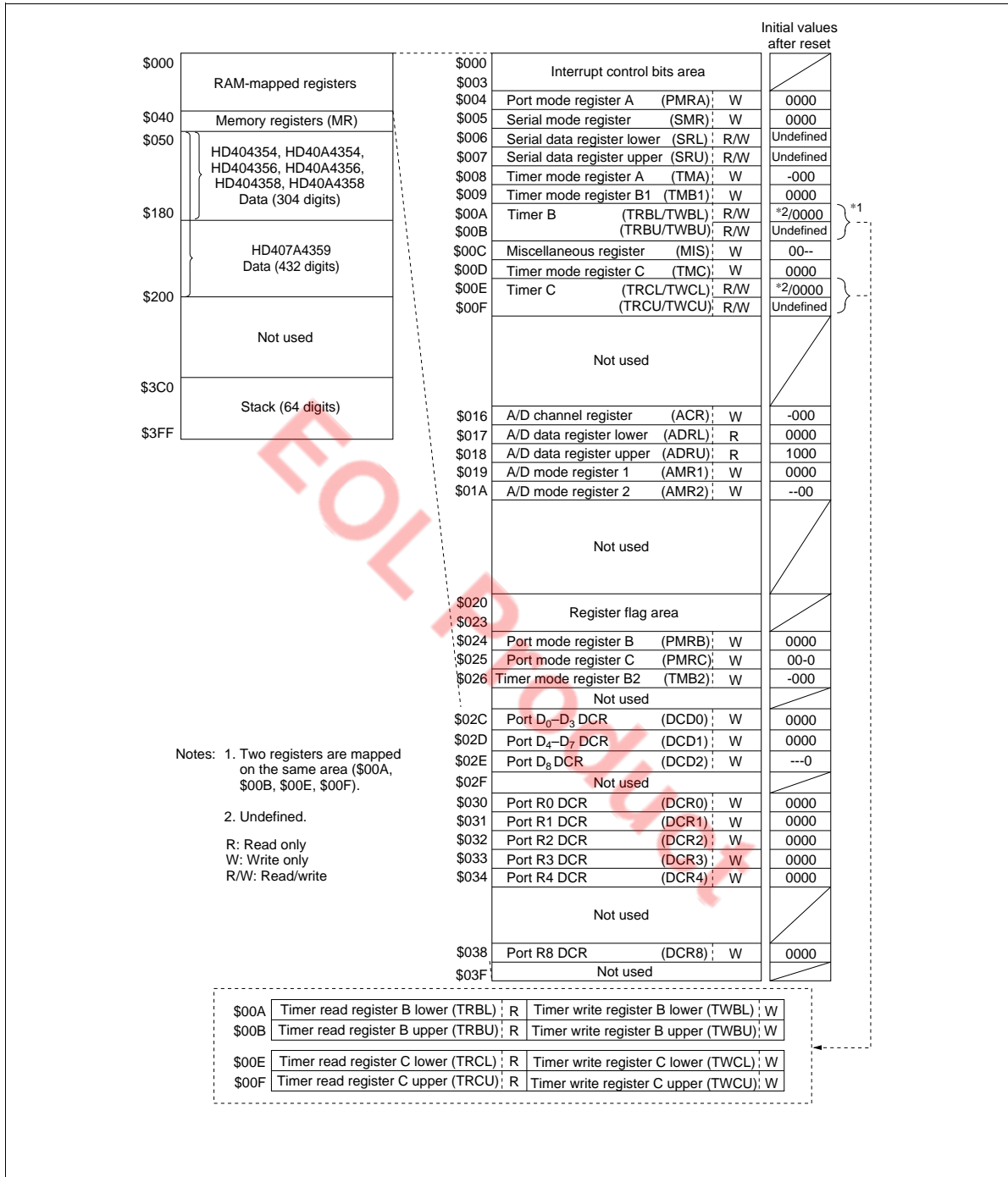

Figure 2 RAM Memory Map

	Bit 3	Bit 2	Bit 1	Bit 0	
0	IM0 (IM of INT ₀)	IF0 (IF of INT ₀)	RSP (Reset SP bit)	IE (Interrupt enable flag)	\$000
1	IMTA (IM of timer A)	IFTA (IF of timer A)	IM1 (IM of INT ₁)	IF1 (IF of INT ₁)	\$001
2	IMTC (IM of timer C)	IFTC (IF of timer C)	IMTB (IM of timer B)	IFTB (IF of timer B)	\$002
3	IMS (IM of serial)	IFS (IF of serial)	IMAD (IM of A/D)	IFAD (IF of A/D)	\$003
Interrupt control bits area					
	Bit 3	Bit 2	Bit 1	Bit 0	
32	Not used	ADSF (A/D start flag)	WDON (Watchdog on flag)	Not used	\$020
33	RAME (RAM enable flag)	IAOF (IAD off flag)	ICEF (Input capture error flag)	ICSF (Input capture status flag)	\$021
34	Not used				\$022
35	Not used				\$023
Register flag area					

IF: Interrupt request flag
 IM: Interrupt mask
 IE: Interrupt enable flag
 SP: Stack pointer

Figure 3 Configuration of Interrupt Control Bits and Register Flag Areas

	SEM/SEMD	REM/REMD	TM/TMD
IE	Allowed	Allowed	Allowed
IM			
IAOF			
IF	Not executed	Allowed	Allowed
ICSF			
ICEF			
RAME			
RSP	Not executed	Allowed	Inhibited
WDON	Allowed	Not executed	Inhibited
ADSF	Allowed	Inhibited	Allowed
Not used	Not executed	Not executed	Inhibited

Note: WDON is reset by MCU reset or by $\overline{\text{STOPC}}$ enable for stop mode cancellation.
 The REM or REMD instruction must not be executed for ADSF during A/D conversion.
 If the TM or TMD instruction is executed for the inhibited bits or non-existing bits, the value in ST becomes invalid.

Figure 4 Usage Limitations of RAM Bit Manipulation Instructions

HD404358 Series

	Bit 3	Bit 2	Bit 1	Bit 0
\$000	Interrupt control bits area			
\$003				
PMRA \$004	D ₃ /BUZZ	R0 ₃ /TOC	R0 ₄ /SI	R0 ₂ /SO
SMR \$005	R0 ₀ /SCK Serial transmit clock speed selection			
SRL \$006	Serial data register (lower digit)			
SRU \$007	Serial data register (upper digit)			
TMA \$008	Not used	Clock source selection (timer A)		
TMB1 \$009	*1	Clock source selection (timer B)		
TRBL/TWBL \$00A	Timer B register (lower digit)			
TRBU/TWBU \$00B	Timer B register (upper digit)			
MIS \$00C	*2	SO PMOS control	Not used	
TMC \$00D	*1	Clock source selection (timer C)		
TRCL/TWCL \$00E	Timer C register (lower digit)			
TRCU/TWCU \$00F	Timer C register (upper digit)			
	Not used			
ACR \$016	Not used	Analog channel selection		
ADRL \$017	A/D data register (lower digit)			
ADRU \$018	A/D data register (upper digit)			
AMR1 \$019	R3 ₃ /AN ₃	R3 ₂ /AN ₂	R3 ₁ /AN ₁	R3 ₀ /AN ₀
AMR2 \$01A	Not used		R4/AN ₄ -AN ₇	*3
	Not used			
\$020	Register flag area			
\$023				
PMRB \$024	D ₄ /STOPC	D ₂ /EVNB	D ₁ /INT ₁	D ₀ /INT ₀
PMRC \$025	Buzzer output		*4	*5
TMB2 \$026	Not used	*6	EVNB detection edge selection	
	Not used			
DCD0 \$02C	Port D ₃ DCD	Port D ₂ DCD	Port D ₁ DCD	Port D ₀ DCD
DCD1 \$02D	Port D ₇ DCD	Port D ₆ DCD	Port D ₅ DCD	Port D ₄ DCD
DCD2 \$02E	Not used			Port D ₃ DCD
	Not used			
DCR0 \$030	Port R0 ₃ DCR	Port R0 ₂ DCR	Port R0 ₁ DCR	Port R0 ₀ DCR
DCR1 \$031	Port R1 ₃ DCR	Port R1 ₂ DCR	Port R1 ₁ DCR	Port R1 ₀ DCR
DCR2 \$032	Port R2 ₃ DCR	Port R2 ₂ DCR	Port R2 ₁ DCR	Port R2 ₀ DCR
DCR3 \$033	Port R3 ₃ DCR	Port R3 ₂ DCR	Port R3 ₁ DCR	Port R3 ₀ DCR
DCR4 \$034	Port R4 ₃ DCR	Port R4 ₂ DCR	Port R4 ₁ DCR	Port R4 ₀ DCR
	Not used			
DCR8 \$038	Port R8 ₃ DCR	Port R8 ₂ DCR	Port R8 ₁ DCR	Port R8 ₀ DCR
	Not used			
\$03F				

- Notes:
1. Auto-reload on/off
 2. Pull-up MOS control
 3. A/D conversion time
 4. SO output level control in idle states
 5. Serial clock source selection
 6. Input capture selection

Figure 5 Special Function Register Area

Memory registers			Stack area		
64	MR(0)	\$040	960	Level 16	\$3C0
65	MR(1)	\$041		Level 15	
66	MR(2)	\$042		Level 14	
67	MR(3)	\$043		Level 13	
68	MR(4)	\$044		Level 12	
69	MR(5)	\$045		Level 11	
70	MR(6)	\$046		Level 10	
71	MR(7)	\$047		Level 9	
72	MR(8)	\$048		Level 8	
73	MR(9)	\$049		Level 7	
74	MR(10)	\$04A		Level 6	
75	MR(11)	\$04B		Level 5	
76	MR(12)	\$04C		Level 4	
77	MR(13)	\$04D		Level 3	
78	MR(14)	\$04E		Level 2	
79	MR(15)	\$04F	1023	Level 1	\$3FF

	Bit 3	Bit 2	Bit 1	Bit 0	
1020	ST	\overline{PC}_{13}	\overline{PC}_{12}	\overline{PC}_{11}	\$3FC
1021	\overline{PC}_{10}	\overline{PC}_9	\overline{PC}_8	\overline{PC}_7	\$3FD
1022	CA	\overline{PC}_6	\overline{PC}_5	\overline{PC}_4	\$3FE
1023	\overline{PC}_3	\overline{PC}_2	\overline{PC}_1	\overline{PC}_0	\$3FF

PC_{13} – PC_0 : Program counter
 ST: Status flag
 CA: Carry flag

Figure 6 Configuration of Memory Registers and Stack Area, and Stack Position

HD404358 Series

Functional Description

Registers and Flags

The MCU has nine registers and two flags for CPU operations. They are shown in figure 7 and described below.

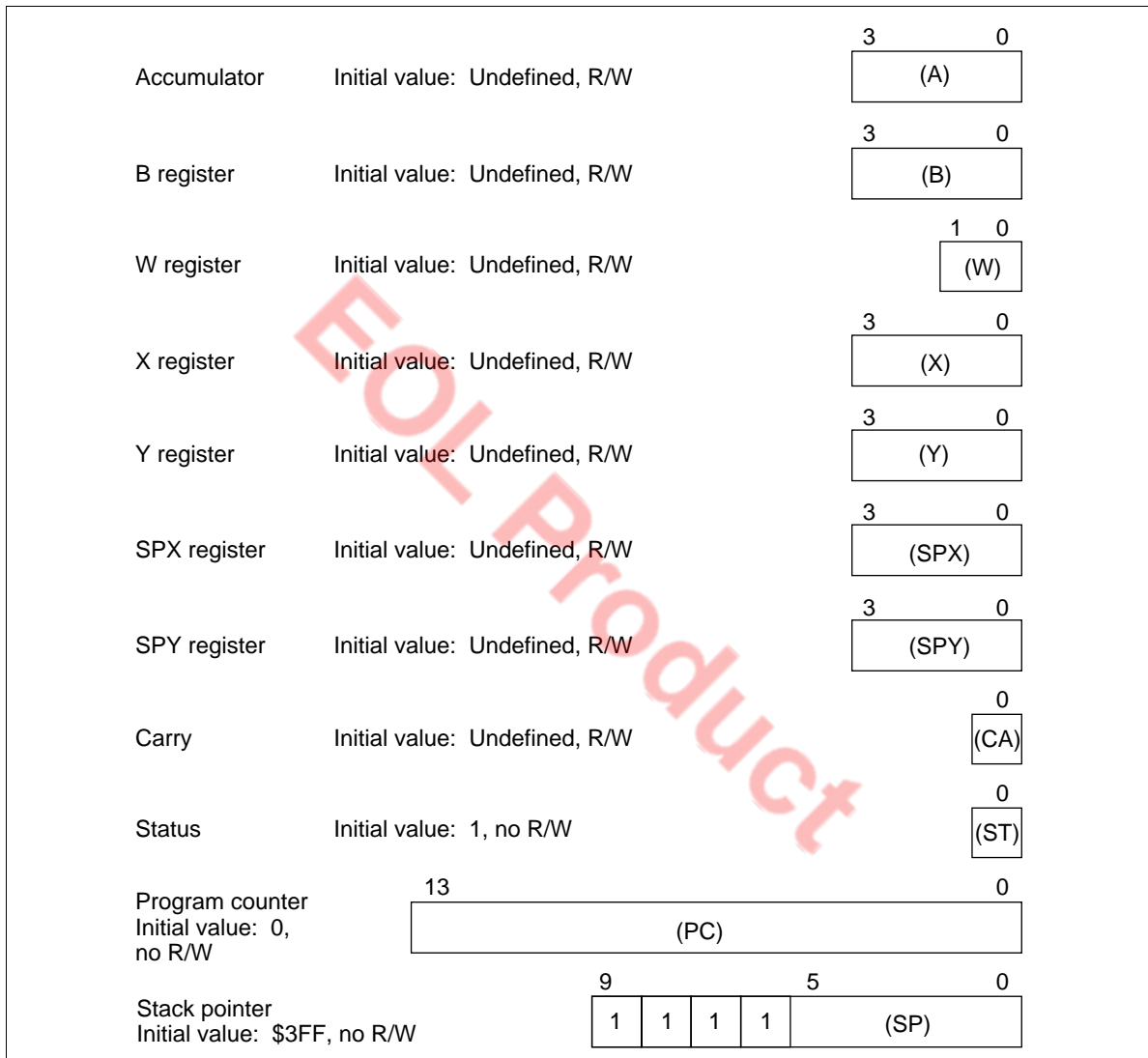

Figure 7 Registers and Flags

Accumulator (A), B Register (B): Four-bit registers used to hold the results from the arithmetic logic unit (ALU) and transfer data between memory, I/O, and other registers.

W Register (W), X Register (X), Y Register (Y): Two-bit (W) and four-bit (X and Y) registers used for indirect RAM addressing. The Y register is also used for D-port addressing.

SPX Register (SPX), SPY Register (SPY): Four-bit registers used to supplement the X and Y registers.

Carry Flag (CA): One-bit flag that stores any ALU overflow generated by an arithmetic operation. CA is affected by the SEC, REC, ROTL, and ROTR instructions. A carry is pushed onto the stack during an interrupt and popped from the stack by the RTNI instruction—but not by the RTN instruction.

Status Flag (ST): One-bit flag that latches any overflow generated by an arithmetic or compare instruction, not-zero decision from the ALU, or result of a bit test. ST is used as a branch condition of the BR, BRL, CAL, and CALL instructions. The contents of ST remain unchanged until the next arithmetic, compare, or bit test instruction is executed, but become 1 after the BR, BRL, CAL, or CALL instruction is read, regardless of whether the instruction is executed or skipped. The contents of ST are pushed onto the stack during an interrupt and popped from the stack by the RTNI instruction—but not by the RTN instruction.

Program Counter (PC): 14-bit binary counter that points to the ROM address of the instruction being executed.

Stack Pointer (SP): Ten-bit pointer that contains the address of the stack area to be used next. The SP is initialized to \$3FF by MCU reset. It is decremented by 4 when data is pushed onto the stack, and incremented by 4 when data is popped from the stack. The top four bits of the SP are fixed at 1111, so a stack can be used up to 16 levels.

The SP can be initialized to \$3FF in another way: by resetting the RSP bit with the REM or REMD instruction.

Reset

The MCU is reset by inputting a high-level voltage to the $\overline{\text{RESET}}$ pin. At power-on or when stop mode is cancelled, $\overline{\text{RESET}}$ must be high for at least one t_{RC} to enable the oscillator to stabilize. During operation, $\overline{\text{RESET}}$ must be high for at least two instruction cycles.

Initial values after MCU reset are listed in table 1.

Interrupts

The MCU has 7 interrupt sources: two external signals ($\overline{\text{INT}}_0$ and $\overline{\text{INT}}_1$), three timer/counters (timers A, B, and C), serial interface, and A/D converter.

An interrupt request flag (IF), interrupt mask (IM), and vector address are provided for each interrupt source, and an interrupt enable flag (IE) controls the entire interrupt process.

Interrupt Control Bits and Interrupt Processing: Locations \$000 to \$003 in RAM are reserved for the interrupt control bits which can be accessed by RAM bit manipulation instructions.

The interrupt request flag (IF) cannot be set by software. MCU reset initializes the interrupt enable flag (IE) and the IF to 0 and the interrupt mask (IM) to 1.

A block diagram of the interrupt control circuit is shown in figure 8, interrupt priorities and vector addresses are listed in table 2, and interrupt processing conditions for the 7 interrupt sources are listed in table 3.

HD404358 Series

An interrupt request occurs when the IF is set to 1 and the IM is set to 0. If the IE is 1 at that point, the interrupt is processed. A priority programmable logic array (PLA) generates the vector address assigned to that interrupt source.

The interrupt processing sequence is shown in figure 9 and an interrupt processing flowchart is shown in figure 10. After an interrupt is acknowledged, the previous instruction is completed in the first cycle. The IE is reset in the second cycle, the carry, status, and program counter values are pushed onto the stack during the second and third cycles, and the program jumps to the vector address to execute the instruction in the third cycle.

Program the JMPL instruction at each vector address, to branch the program to the start address of the interrupt program, and reset the IF by a software instruction within the interrupt program.

EOL Product

Table 1 Initial Values After MCU Reset

Item	Abbr.	Initial Value	Contents	
Program counter	(PC)	\$0000	Indicates program execution point from start address of ROM area	
Status flag	(ST)	1	Enables conditional branching	
Stack pointer	(SP)	\$3FF	Stack level 0	
Interrupt flags/mask	Interrupt enable flag	(IE)	0	Inhibits all interrupts
	Interrupt request flag	(IF)	0	Indicates there is no interrupt request
	Interrupt mask	(IM)	1	Prevents (masks) interrupt requests
I/O	Port data register	(PDR)	All bits 1	Enables output at level 1
	Data control register	(DCD0 – DCD1)	All bits 0	Turns output buffer off (to high impedance)
		(DCD2)	- - - 0	
		(DCR0 – DCR4, DCR8)	All bits 0	
	Port mode register A	(PMRA)	0000	Refer to description of port mode register A
	Port mode register B bits 2–0	(PMRB2 – PMRB0)	000	Refer to description of port mode register B
	Port mode register C	(PMRC)	00 - 0	Refer to description of port mode register C
Timer/counters, serial interface	Timer mode register A	(TMA)	- 000	Refer to description of timer mode register A
	Timer mode register B1	(TMB1)	0000	Refer to description of timer mode register B1
	Timer mode register B2	(TMB2)	- 000	Refer to description of timer mode register B2
	Timer mode register C	(TMC)	0000	Refer to description of timer mode register C
	Serial mode register	(SMR)	0000	Refer to description of serial mode register
	Prescaler S	(PSS)	\$000	—
	Timer counter A	(TCA)	\$00	—
	Timer counter B	(TCB)	\$00	—
	Timer counter C	(TCC)	\$00	—
	Timer write register B	(TWBU, TWBL)	\$X0	—
	Timer write register C	(TWCU, TWCL)	\$X0	—
	Octal counter		000	—

HD404358 Series

Item		Abbr.	Initial Value	Contents
A/D	A/D mode register 1	(AMR1)	0000	Refer to description of A/D mode register
	A/D mode register 2	(AMR2)	- - 00	
	A/D channel register	(ACR)	- 000	Refer to description of A/D channel register
	A/D data register	(ADRL)	0000	
		(ADRU)	1000	
Bit registers	Watchdog timer on flag	(WDON)	0	Refer to description of timer C
	A/D start flag	(ADSF)	0	Refer to description of A/D converter
	I _{AD} off flag	(IAOF)	0	Refer to the description of A/D converter
	Input capture status flag	(ICSF)	0	Refer to description of timer B
	Input capture error flag	(ICEF)	0	Refer to description of timer B
Others	Miscellaneous register	(MIS)	00 - -	Refer to description of operating modes, I/O, and serial interface

- Notes: 1. The statuses of other registers and flags after MCU reset are shown in the following table.
 2. X indicates invalid value. – indicates that the bit does not exist.

Item	Abbr.	Status After Cancellation of Stop Mode by $\overline{\text{STOPC}}$ Input	Status After all Other Types of Reset
Carry flag	(CA)	Pre-stop-mode values are not guaranteed; values must be initialized by program	Pre-MCU-reset values are not guaranteed; values must be initialized by program
Accumulator	(A)		
B register	(B)		
W register	(W)		
X/SPX register	(X/SPX)		
Y/SPY register	(Y/SPY)		
Serial data register	(SRL, SRU)		
RAM		Pre-stop-mode values are retained	
RAM enable flag	(RAME)	1	0
Port mode register B bit 3	(PMRB3)	Pre-stop-mode values are retained	0

Table 2 Vector Addresses and Interrupt Priorities

Reset/Interrupt	Priority	Vector Address
RESET, STOPC*	—	\$0000
$\overline{\text{INT}}_0$	1	\$0002
$\overline{\text{INT}}_1$	2	\$0004
Timer A	3	\$0006
Timer B	4	\$0008
Timer C	5	\$000A
A/D	6	\$000C
Serial	7	\$000E

Note: * The STOPC interrupt request is valid only in stop mode.

EOL Product

HD404358 Series

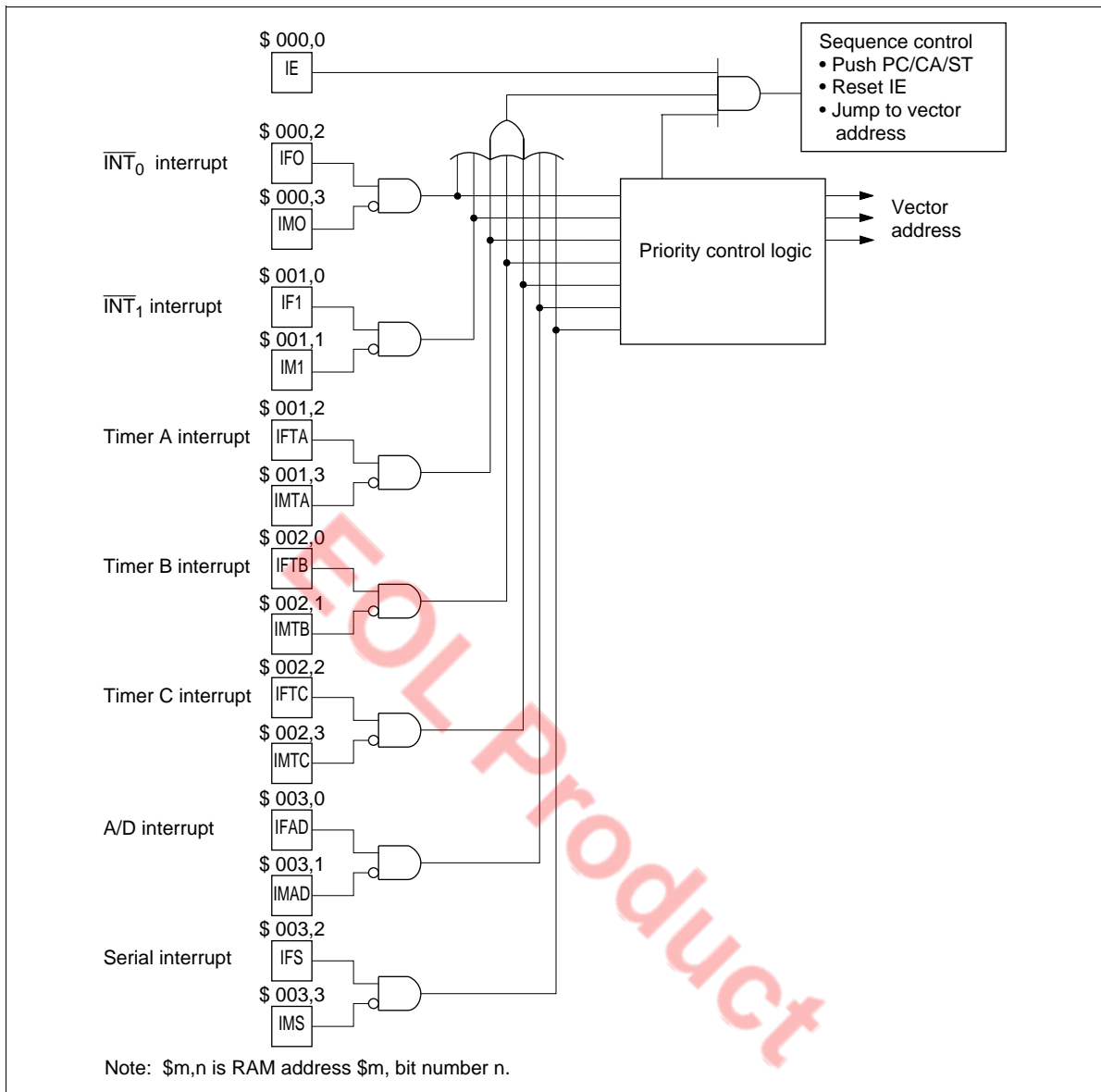

Figure 8 Interrupt Control Circuit

Table 3 Interrupt Processing and Activation Conditions

	Interrupt Source						
	\overline{INT}_0	\overline{INT}_1	Timer A	Timer B	Timer C	A/D	Serial
IE	1	1	1	1	1	1	1
IF0 · $\overline{IM0}$	1	0	0	0	0	0	0
IF1 · $\overline{IM1}$	*	1	0	0	0	0	0
IFTA · \overline{IMTA}	*	*	1	0	0	0	0
IFTB · \overline{IMTB}	*	*	*	1	0	0	0
IFTC · \overline{IMTC}	*	*	*	*	1	0	0
IFAD · \overline{IMAD}	*	*	*	*	*	1	0
IFS · \overline{IMS}	*	*	*	*	*	*	1

Note: Bits marked * can be either 0 or 1. Their values have no effect on operation.

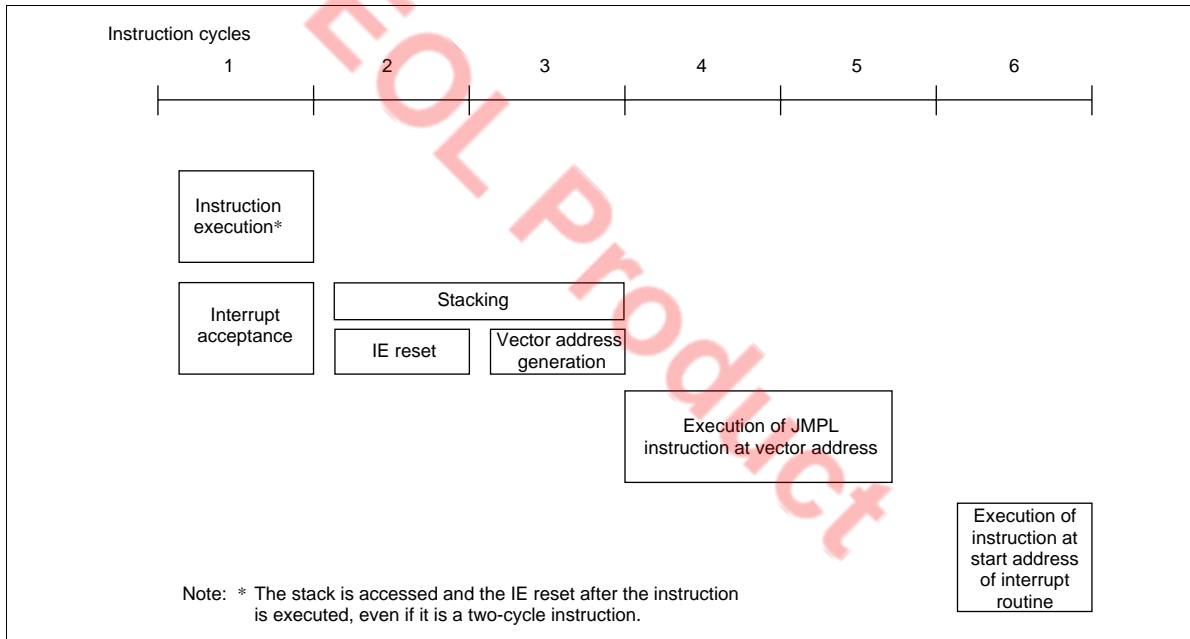

Figure 9 Interrupt Processing Sequence

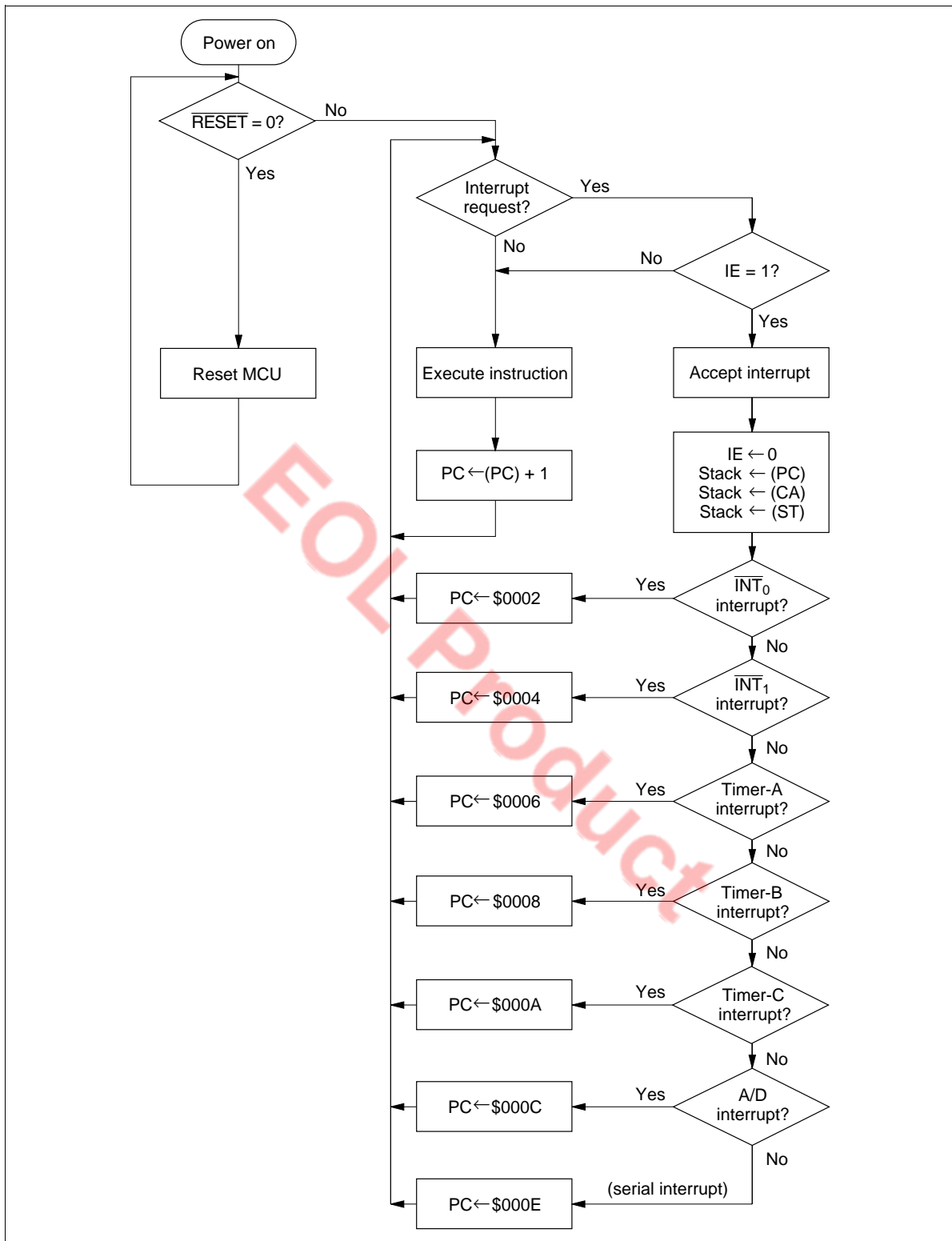

Figure 10 Interrupt Processing Flowchart

Interrupt Enable Flag (IE: \$000, Bit 0): Controls the entire interrupt process. It is reset by the interrupt processing and set by the RTNI instruction, as listed in table 4.

Table 4 Interrupt Enable Flag (IE: \$000, Bit 0)

IE	Interrupt Enabled/Disabled
0	Disabled
1	Enabled

External Interrupts (\overline{INT}_0 , \overline{INT}_1): Two external interrupt signals.

External Interrupt Request Flags (IF0: \$000, Bit 2; IF1: \$001, Bit 0): IF0 and IF1 are set at the rising edge of signals input to \overline{INT}_0 and \overline{INT}_1 , as listed in table 5.

Table 5 External Interrupt Request Flags (IF0: \$000, Bit2; IF1: \$001, Bit 0)

IF0, IF1	Interrupt Request
0	No
1	Yes

External Interrupt Masks (IM0: \$000, Bit 3; IM1: \$001, Bit 1): Prevent (mask) interrupt requests caused by the corresponding external interrupt request flags, as listed in table 6.

Table 6 External Interrupt Masks (IM0: \$000, Bit 3; IM1: \$001, Bit 1)

IM0, IM1	Interrupt Request
0	Enabled
1	Disabled (masked)

Timer A Interrupt Request Flag (IFTA: \$001, Bit 2): Set by overflow output from timer A, as listed in table 7.

Table 7 Timer A Interrupt Request Flag (IFTA: \$001, Bit 2)

IFTA	Interrupt Request
0	No
1	Yes

Timer A Interrupt Mask (IMTA: \$001, Bit 3): Prevents (masks) an interrupt request caused by the timer A interrupt request flag, as listed in table 8.

HD404358 Series

Table 8 **Timer A Interrupt Mask (IMTA: \$001, Bit 3)**

IMTA	Interrupt Request
0	Enabled
1	Disabled (masked)

Timer B Interrupt Request Flag (IFTB: \$002, Bit 0): Set by overflow output from timer B, as listed in table 9.

Table 9 **Timer B Interrupt Request Flag (IFTB: \$002, Bit 0)**

IFTB	Interrupt Request
0	No
1	Yes

Timer B Interrupt Mask (IMTB: \$002, Bit 1): Prevents (masks) an interrupt request caused by the timer B interrupt request flag, as listed in table 10.

Table 10 **Timer B Interrupt Mask (IMTB: \$002, Bit 1)**

IMTB	Interrupt Request
0	Enabled
1	Disabled (masked)

Timer C Interrupt Request Flag (IFTC: \$002, Bit 2): Set by overflow output from timer C, as listed in table 11.

Table 11 **Timer C Interrupt Request Flag (IFTC: \$002, Bit 2)**

IFTC	Interrupt Request
0	No
1	Yes

Timer C Interrupt Mask (IMTC: \$002, Bit 3): Prevents (masks) an interrupt request caused by the timer C interrupt request flag, as listed in table 12.

Table 12 **Timer C Interrupt Mask (IMTC: \$002, Bit 3)**

IMTC	Interrupt Request
0	Enabled
1	Disabled (masked)

Serial Interrupt Request Flag (IFS: \$003, Bit 2): Set when data transfer is completed or when data transfer is suspended, as listed in table 13.

Table 13 Serial Interrupt Request Flag (IFS: \$003, Bit 2)

IFS	Interrupt Request
0	No
1	Yes

Serial Interrupt Mask (IMS: \$003, Bit 3): Prevents (masks) an interrupt request caused by the serial interrupt request flag, as listed in table 14.

Table 14 Serial Interrupt Mask (IMS: \$003, Bit 3)

Mask IMS	Interrupt Request
0	Enabled
1	Disabled (masked)

A/D Interrupt Request Flag (IFAD: \$003, Bit 0): Set at the completion of A/D conversion, as listed in table 15.

Table 15 A/D Interrupt Request Flag (IFAD: \$003, Bit 0)

IFAD	Interrupt Request
0	No
1	Yes

A/D Interrupt Mask (IMAD: \$003, Bit 1): Prevents (masks) an interrupt request caused by the A/D interrupt request flag, as listed in table 16.

Table 16 A/D Interrupt Mask (IMAD: \$003, Bit 1)

IMAD	Interrupt Request
0	Enabled
1	Disabled (masked)

HD40358 Series

Operating Modes

The MCU has three operating modes as shown in table 17. The operations in each mode are listed in tables 18 and 19. Transitions between operating modes are shown in figure 11.

Table 17 Operating Modes and Clock Status

		Mode Name		
		Active	Standby	Stop
Activation method		$\overline{\text{RESET}}$ cancellation, interrupt request, $\overline{\text{STOPC}}$ cancellation in stop mode	SBY instruction	STOP instruction
Status	System oscillator	OP	OP	Stopped
Cancellation method		$\overline{\text{RESET}}$ input, STOP/ SBY instruction	$\overline{\text{RESET}}$ input, interrupt request	$\overline{\text{RESET}}$ input, $\overline{\text{STOPC}}$ input in stop mode

Note: OP implies in operation

Table 18 Operations in Low-Power Dissipation Modes

Function	Stop Mode	Standby Mode
CPU	Reset	Retained
RAM	Retained	Retained
Timer A	Reset	OP
Timer B	Reset	OP
Timer C	Reset	OP
Serial	Reset	OP
A/D	Reset	OP
I/O	Reset	Retained

Note: OP implies in operation

Table 19 I/O Status in Low-Power Dissipation Modes

	Output		Input
	Standby Mode	Stop Mode	Active Mode
RA ₁	—	—	Input enabled
R ₀ –D ₈ , R0–R4, R8,	Retained or output of peripheral functions	High impedance	Input enabled

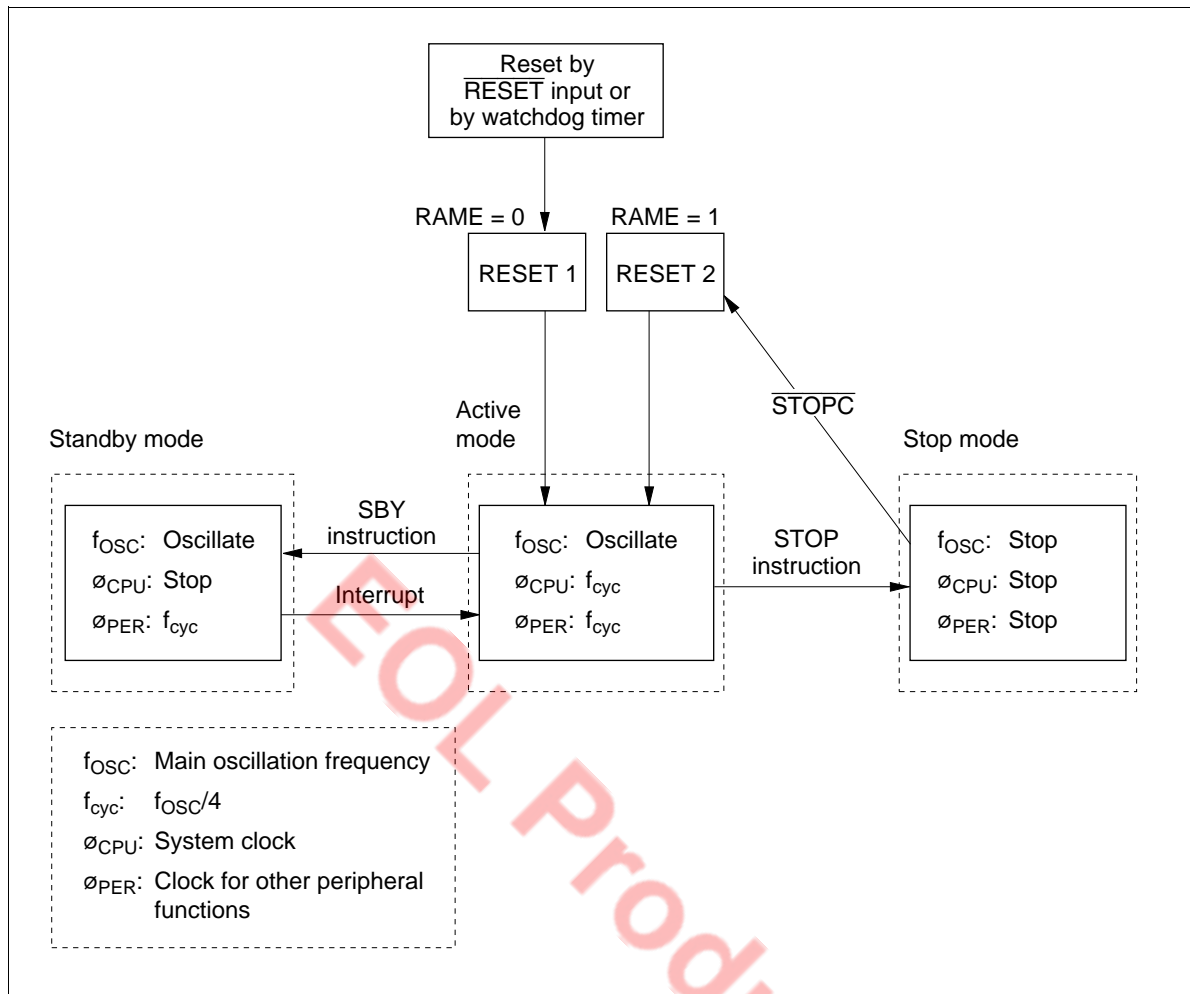

Figure 11 MCU Status Transitions

Active Mode: All MCU functions operate according to the clock generated by the system oscillator OSC₁ and OSC₂.

Standby Mode: In standby mode, the oscillators continue to operate, but the clocks related to instruction execution stop. Therefore, the CPU operation stops, but all RAM and register contents are retained, and the D or R port status, when set to output, is maintained. Peripheral functions such as interrupts, timers, and serial interface continue to operate. The power dissipation in this mode is lower than in active mode because the CPU stops.

The MCU enters standby mode when the SBY instruction is executed in active mode.

Standby mode is terminated by a $\overline{\text{RESET}}$ input or an interrupt request. If it is terminated by $\overline{\text{RESET}}$ input, the MCU is reset as well. After an interrupt request, the MCU enters active mode and executes the next instruction after the SBY instruction. If the interrupt enable flag is 1, the interrupt is then processed; if it is 0, the interrupt request is left pending and normal instruction execution continues. A flowchart of operation in standby mode is shown in figure 12.

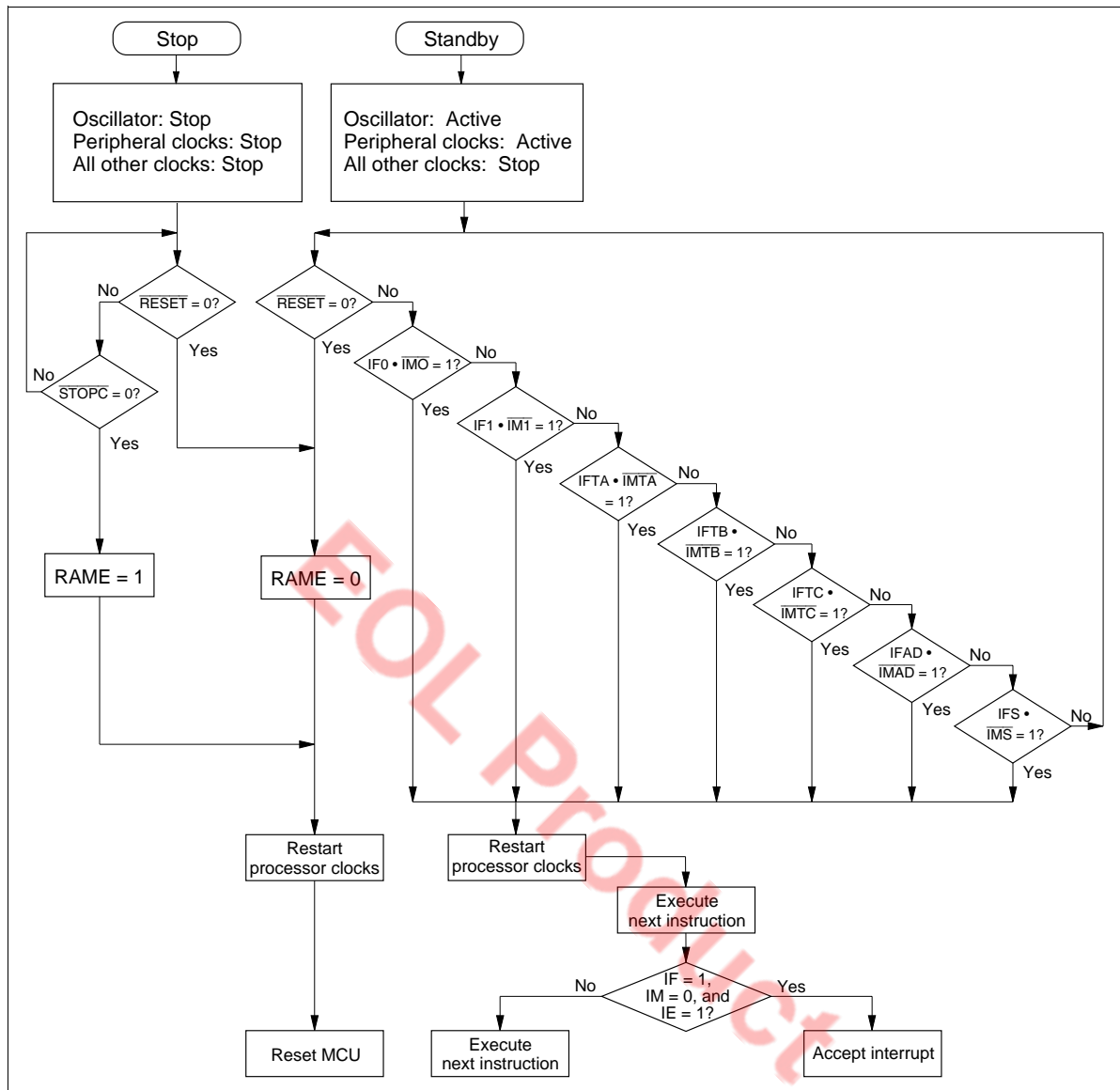

Figure 12 MCU Operation Flowchart

Stop Mode: In stop mode, all MCU operations stop and RAM data is retained. Therefore, the power dissipation in this mode is the least of all modes. The OSC₁ and OSC₂ oscillator stops.

Stop mode is terminated by a $\overline{\text{RESET}}$ input or a $\overline{\text{STOPC}}$ input as shown in figure 13. $\overline{\text{RESET}}$ or $\overline{\text{STOPC}}$ must be applied for at least one t_{RC} to stabilize oscillation (refer to the AC Characteristics section). When the MCU restarts after stop mode is cancelled, all RAM contents before entering stop mode are retained, but the accuracy of the contents of the accumulator, B register, W register, X/SPX register, Y/SPY register, carry flag, and serial data register cannot be guaranteed.

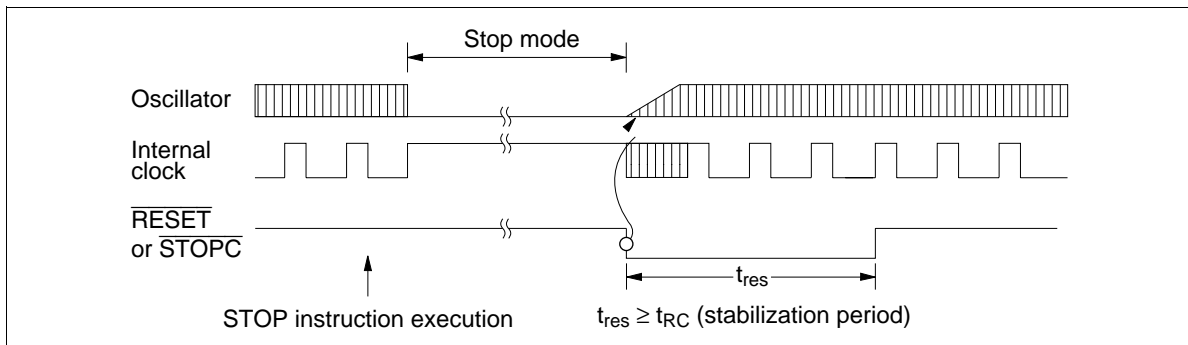

Figure 13 Timing of Stop Mode Cancellation

Stop Mode Cancellation by $\overline{\text{STOPC}}$: The MCU enters active mode from stop mode by inputting $\overline{\text{STOPC}}$ as well as by $\overline{\text{RESET}}$. In either case, the MCU starts instruction execution from the starting address (address 0) of the program. However, the value of the RAM enable flag (RAME: \$021, bit 3) differs between cancellation by $\overline{\text{STOPC}}$ and by $\overline{\text{RESET}}$. When stop mode is cancelled by $\overline{\text{RESET}}$, RAME = 0; when cancelled by $\overline{\text{STOPC}}$, RAME = 1. $\overline{\text{RESET}}$ can cancel all modes, but $\overline{\text{STOPC}}$ is valid only in stop mode; $\overline{\text{STOPC}}$ input is ignored in other modes. Therefore, when the program requires to confirm that stop mode has been cancelled by $\overline{\text{STOPC}}$ (for example, when the RAM contents before entering stop mode is used after transition to active mode), execute the TEST instruction to the RAM enable flag (RAME) at the beginning of the program.

MCU Operation Sequence: The MCU operates in the sequence shown in figure 15. It is reset by an asynchronous $\overline{\text{RESET}}$ input, regardless of its status.

The low-power mode operation sequence is shown in figure 16. With the IE flag cleared and an interrupt flag set together with its interrupt mask cleared, if a STOP/SBY instruction is executed, the instruction is cancelled (regarded as an NOP) and the following instruction is executed. Before executing a STOP/SBY instruction, make sure all interrupt flags are cleared or all interrupts are masked.

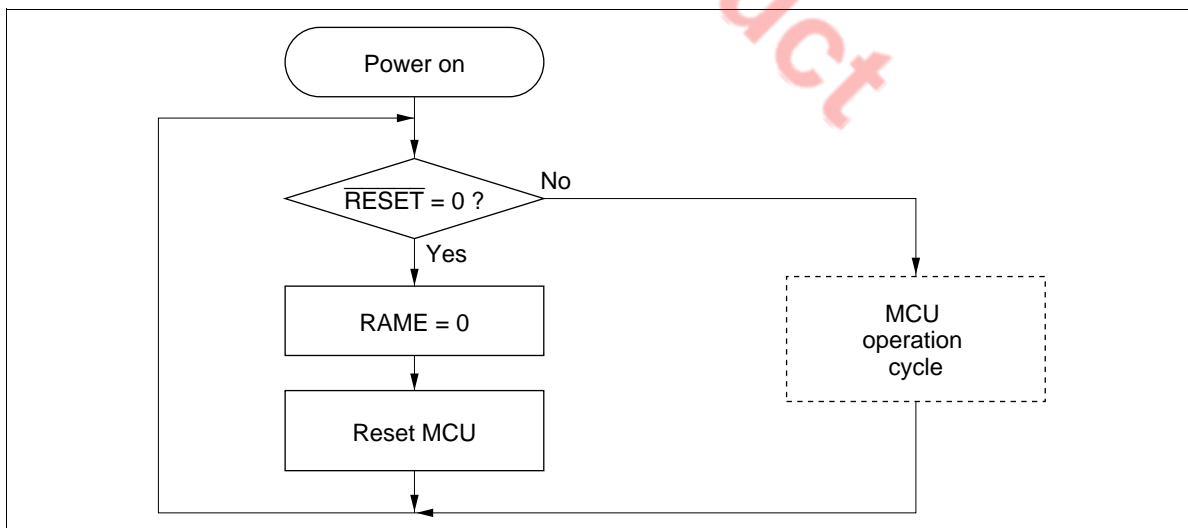

Figure 14 MCU Operating Sequence (Power On)

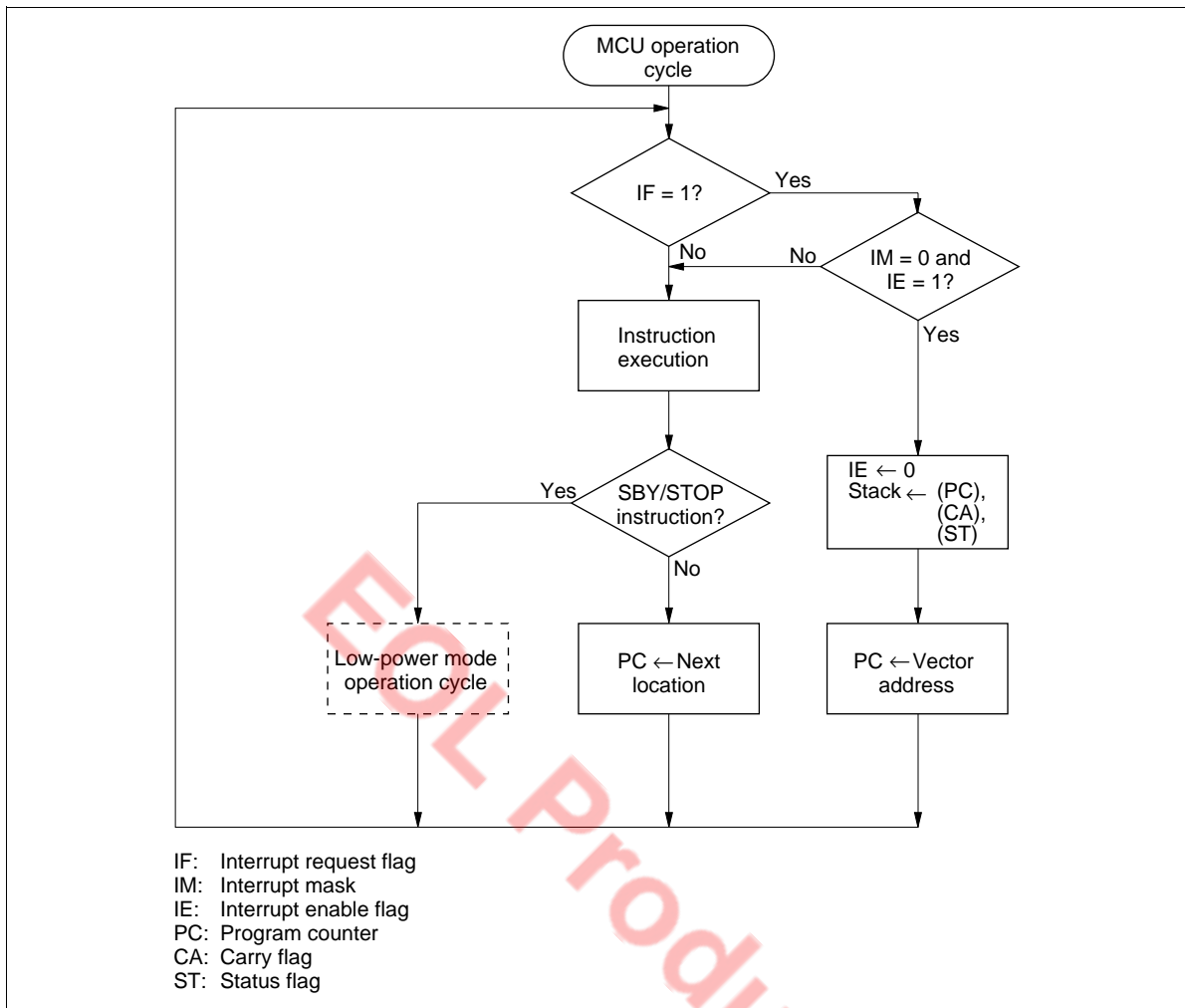

Figure 15 MCU Operating Sequence (MCU Operation Cycle)

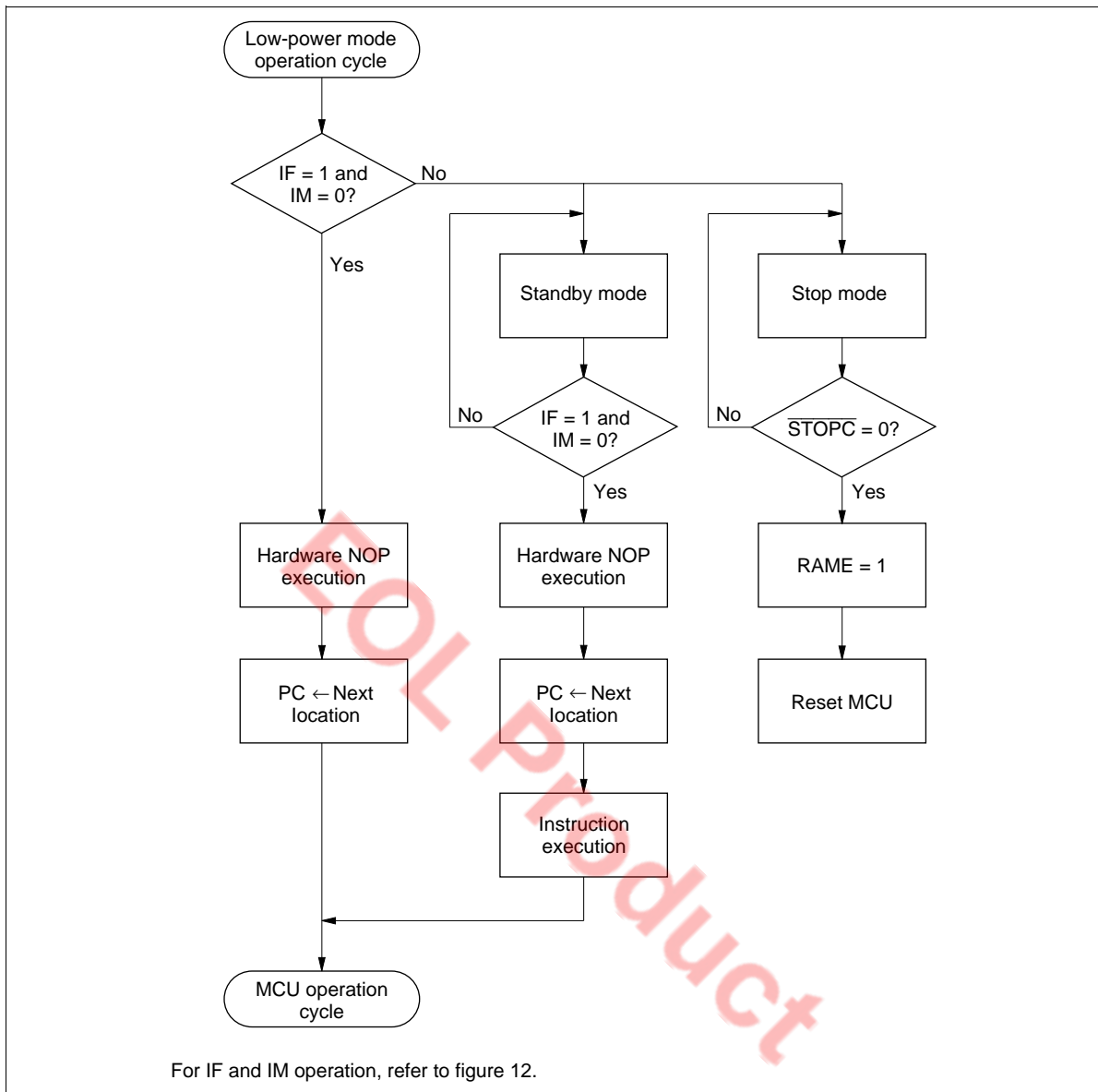

Figure 16 MCU Operating Sequence (Low-Power Mode Operation)

Internal Oscillator Circuit

A block diagram of the clock generation circuit is shown in figure 17. As shown in table 20, a ceramic oscillator or crystal oscillator can be connected to OSC₁ and OSC₂. The system oscillator can also be operated by an external clock. See figure 18 for the layout of crystal and ceramic oscillator.

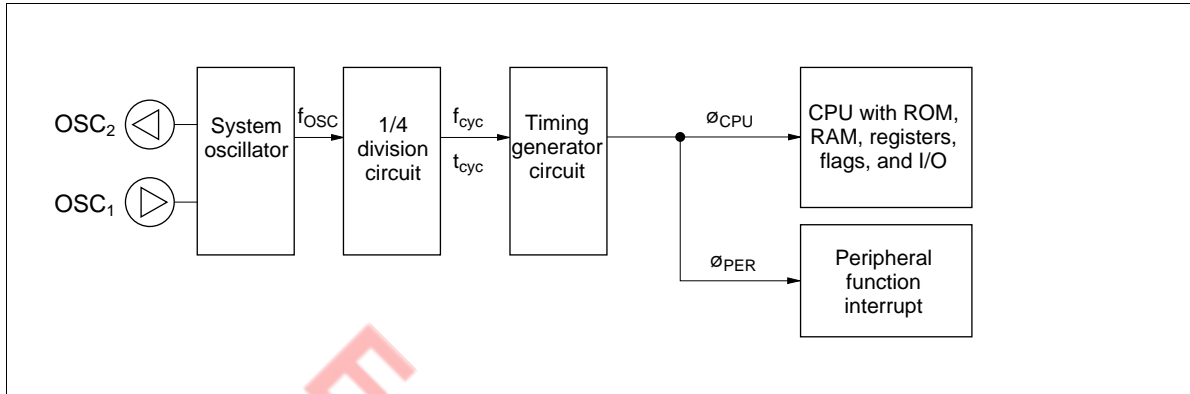

Figure 17 Clock Generation Circuit

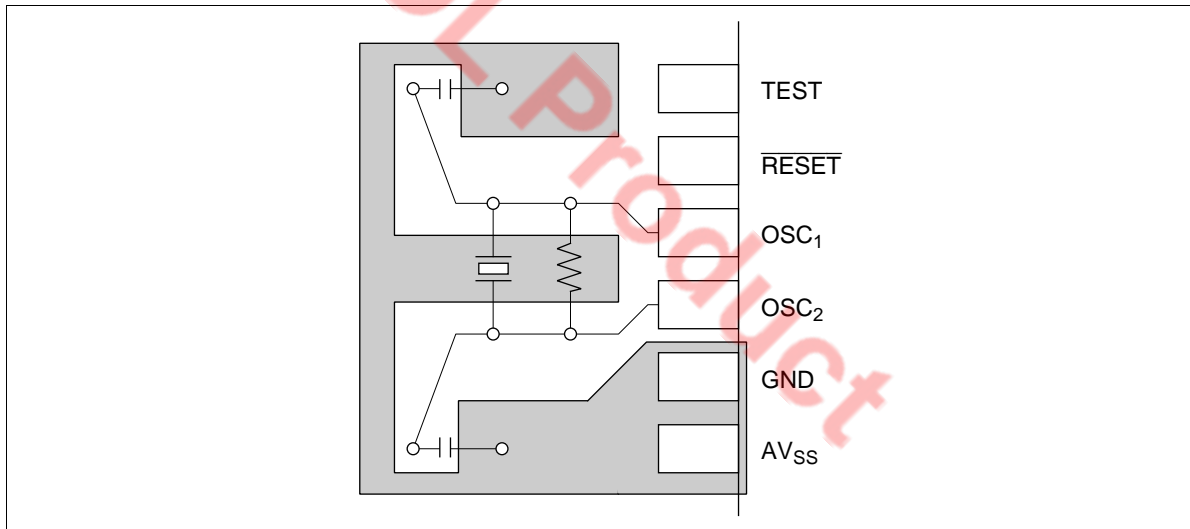
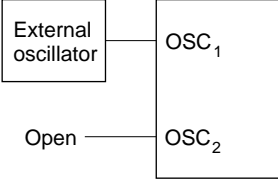
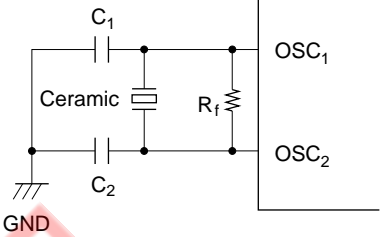
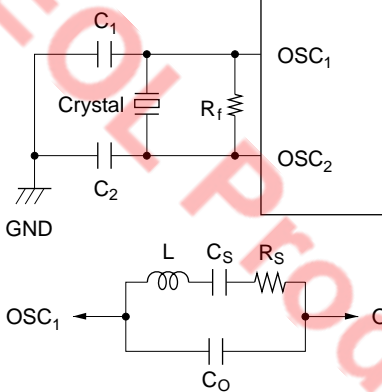

Figure 18 Typical Layout of Crystal and Ceramic Oscillator

Table 20 Oscillator Circuit Examples

Circuit Configuration	Circuit Constants
<p>External clock operation</p> 	
<p>Ceramic oscillator (OSC₁, OSC₂)</p> 	<p>Ceramic oscillator: CSA4.00MG (Murata) $R_f = 1\text{ M}\Omega \pm 20\%$ $C_1 = C_2 = 30\text{ pF} \pm 20\%$</p>
<p>Crystal oscillator (OSC₁, OSC₂)</p> 	<p>$R_f = 1\text{ M}\Omega \pm 20\%$ $C_1 = C_2 = 10\text{ to }22\text{ pF} \pm 20\%$ Crystal: Equivalent to circuit shown below $C_0 = 7\text{ pF max.}$ $R_s = 100\ \Omega\text{ max.}$</p>

- Notes:
1. Since the circuit constants change depending on the crystal or ceramic oscillator and stray capacitance of the board, the user should consult with the crystal or ceramic oscillator manufacturer to determine the circuit parameters.
 2. Wiring among OSC₁, OSC₂, and elements should be as short as possible, and must not cross other wiring (see figure 18).

HD404358 Series

Input/Output

The MCU has 33 input/output pins (D_0 – D_8 , R_0 – R_4 , R_8) and an input pin (RA_1). The features are described below.

- Four pins (R_{2_0} – R_{2_3}) are high-current (15 mA max) input/output with intermediate voltage NMOS open drain pins.
- The D_0 – D_4 , R_0 , R_3 – R_4 input/output pins are multiplexed with peripheral function pins such as for the timers or serial interface. For these pins, the peripheral function setting is done prior to the D or R port setting. Therefore, when a peripheral function is selected for a pin, the pin function and input/output selection are automatically switched according to the setting.
- Input or output selection for input/output pins and port or peripheral function selection for multiplexed pins are set by software.
- Peripheral function output pins are CMOS output pins. Only the R_{0_2}/SO pin can be set to NMOS open-drain output by software.
- In stop mode, the MCU is reset, and therefore peripheral function selection is cancelled. Input/output pins are in high-impedance state.
- Each input/output pin except for R_2 has a built-in pull-up MOS, which can be individually turned on or off by software.

I/O buffer configuration is shown in figure 19, programmable I/O circuits are listed in table 21, and I/O pin circuit types are shown in table 22.

Table 21 Programmable I/O Circuits

MIS3 (bit 3 of MIS)		0				1			
DCD, DCR		0		1		0		1	
PDR		0	1	0	1	0	1	0	1
CMOS buffer	PMOS	—	—	—	On	—	—	—	On
	NMOS	—	—	On	—	—	—	On	—
Pull-up MOS		—	—	—	—	—	On	—	On

Note: — indicates off status.

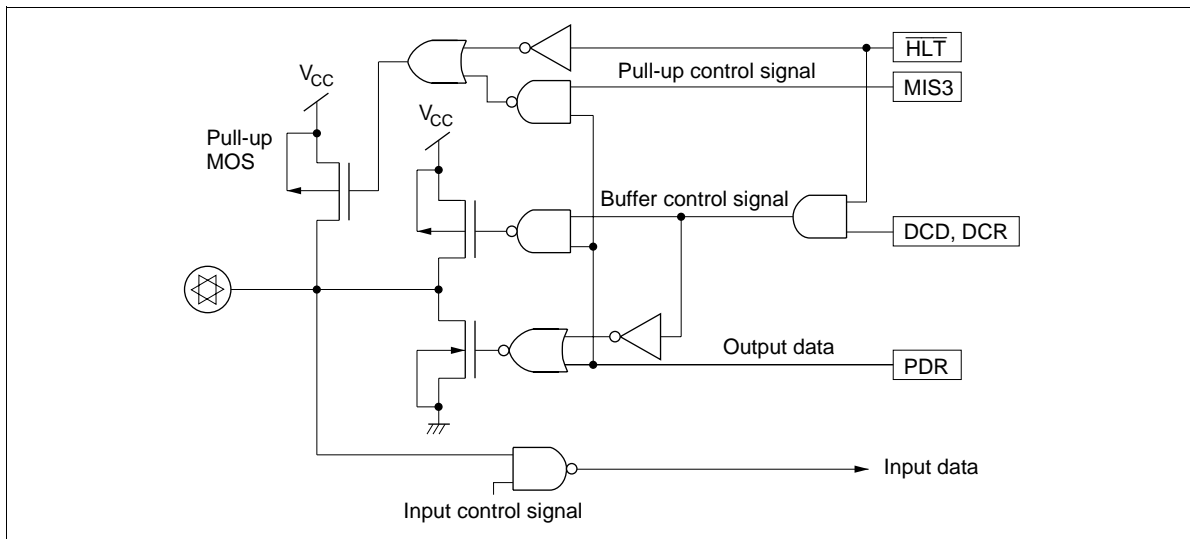

Figure 19 I/O Buffer Configuration

EOL Product

HD404358 Series

Table 22 Circuit Configurations of I/O Pins

I/O Pin Type	Circuit	Pins
Input/output pins	<p>Input control signal</p>	D_0-D_8 , $R0_0, R0_1, R0_3$ $R1_0-R1_3$, $R3_0-R3_3$, $R4_0-R4_3$, $R8_0-R8_3$
	<p>Input control signal</p>	$R0_2$
	<p>Input control signal</p>	$R2_0-R2_3$
Input pins	<p>Input control signal</p>	RA_1
Peripheral function pins	<p>Input control signal</p>	SCK

Notes on next page.

I/O Pin Type	Circuit	Pins
Peripheral function pins	<p>Output pins</p>	SO
		TOC, BUZZ
Input pins		SI, \overline{INT}_0 , \overline{INT}_1 , EVNB, \overline{STOPC}
		AN_0 - AN_7

- Notes:
1. In stop mode, the MCU is reset and the peripheral function selection is cancelled. The \overline{HLT} signal goes low, and input/output pins enter the high-impedance state.
 2. The \overline{HLT} signal is 1 in active and standby modes.

HD404358 Series

Evaluation Chip Set and ZTAT™/Mask ROM Product Differences

As shown in figure 20, the NMOS intermediate breakdown voltage open drain pin circuit in the evaluation chip set differs from that used in the ZTAT™ microcomputer and built-in mask ROM microcomputer products.

Please note that although these outputs in the ZTAT™ microcomputer and built-in mask ROM microcomputer products can be set to high impedance by the combinations shown in table 23, these outputs cannot be set to high impedance in the evaluation chip set.

Table 23 Program Control of High Impedance States

Register	Set Value	
DCR	0	1
PDR	*	1

Notes: * An asterisk indicates that the value may be either 0 or 1 and has no influence on circuit operation. This applies to the ZTAT™ and built-in mask ROM microcomputer NMOS open drain pins.

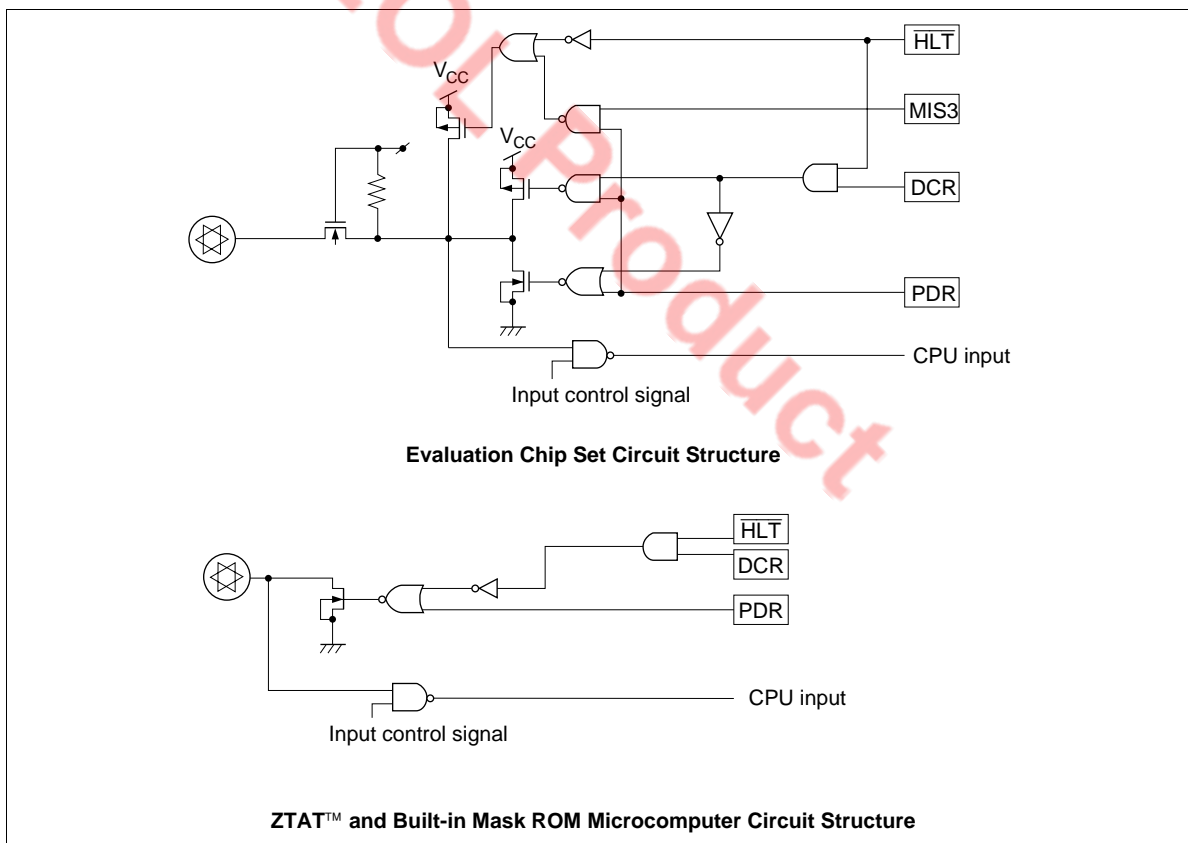

Figure 20 NMOS Intermediate Breakdown Voltage Open Drain Pin Circuits

D Port (D₀–D₈): Consist of 9 input/output pins addressed by one bit.

Pins D₀–D₈ are set by the SED and SEDD instructions, and reset by the RED and REDD instructions. Output data is stored in the port data register (PDR) for each pin. All pins D₀–D₈ are tested by the TD and TDD instructions.

The on/off statuses of the output buffers are controlled by D-port data control registers (DCD0–DCD2: \$02C–\$02E) that are mapped to memory addresses (figure 21).

Pins D₀–D₂, D₄ are multiplexed with peripheral function pins $\overline{\text{INT0}}$, $\overline{\text{INT1}}$, EVNB, and $\overline{\text{STOPC}}$, respectively. The peripheral function modes of these pins are selected by bits 0–3 (PMRB0–PMRB3) of port mode register B (PMRB: \$024) (figure 22).

Pin D₃ is multiplexed with peripheral function pin BUZZ. The peripheral function mode of this pin is selected by bit 3 (PMRA3) of port mode register A (PMRA: \$004) (figure 23).

R Ports (R₀–R₄, R₈): 24 input/output pins addressed in 4-bit units. Data is input to these ports by the LAR and LBR instructions, and output from them by the LRA and LRB instructions. Output data is stored in the port data register (PDR) for each pin. The on/off statuses of the output buffers of the R ports are controlled by R-port data control registers (DCR0–DCR4: \$030–\$034, DCR8: \$038) that are mapped to memory addresses (figure 21).

Pin R₀ is multiplexed with peripheral function pin $\overline{\text{SCK}}$. The peripheral function mode of this pin is selected by bit 3 (SMR3) of serial mode register (SMR: \$005) (figure 24).

Pins R₀–R₃ are multiplexed with peripheral pins SI, SO and TOC, respectively. The peripheral function modes of these pins are selected by bits 0–2 (PMRA0–PMRA2) of port mode register A (PMRA: \$004), as shown in figures 23.

Port R₃ is multiplexed with peripheral function pins AN₀–AN₃, respectively. The peripheral function modes of these pins can be selected by individual pins, by setting A/D mode register 1 (AMR1: \$019) (figure 25).

Ports R₄ is multiplexed with peripheral function pins AN₄–AN₇, respectively. The peripheral function modes of these pins can be selected in 4-pin units by setting bit 1 (AMR21) of A/D mode register 2 (AMR2: \$01A) (figure 26).

Pull-Up MOS Transistor Control: A program-controlled pull-up MOS transistor is provided for each input/output pin. The on/off status of all these transistors is controlled by bit 3 (MIS3) of the miscellaneous register (MIS: \$00C), and the on/off status of an individual transistor can also be controlled by the port data register (PDR) of the corresponding pin—enabling on/off control of that pin alone (table 21 and figure 27).

The on/off status of each transistor and the peripheral function mode of each pin can be set independently.

How to Deal with Unused I/O Pins: I/O pins that are not needed by the user system (floating) must be connected to V_{CC} to prevent LSI malfunctions due to noise. These pins must either be pulled up to V_{CC} by their pull-up MOS transistors or by resistors of about 100 k Ω .

HD404358 Series

**Data control register (DCD0 to 2: \$02C to \$02E)
(DCR0 to 4: \$030 to \$034, DCR8: \$038)**

DCD0, DCD2, DCR0 to DCR4, DCR8

Bit	3	2	1	0
Initial value	0	0	0	0
Read/Write	W	W	W	W
Bit name	DCD03, DCD13, DCR03– DCR43, DCR83	DCD02, DCD12, DCR02– DCR42, DCR82	DCD01, DCD11, DCR01– DCR41, DCR81	DCD00– DCD20, DCR00– DCR40, DCR80

Bits 0 to 3 CMOS Buffer On/Off Selection

0	Off (high-impedance)
1	On

Correspondence between ports and DCD/DCR bits

Register Name	Bit 3	Bit 2	Bit 1	Bit 0
DCD0	D ₃	D ₂	D ₁	D ₀
DCD1	D ₇	D ₆	D ₅	D ₄
DCD2	Not used	Not used	Not used	D ₈
DCR0	R ₀₃	R ₀₂	R ₀₁	R ₀₀
DCR1	R ₁₃	R ₁₂	R ₁₁	R ₁₀
DCR2	R ₂₃	R ₂₂	R ₂₁	R ₂₀
DCR3	R ₃₃	R ₃₂	R ₃₁	R ₃₀
DCR4	R ₄₃	R ₄₂	R ₄₁	R ₄₀
DCR8	R ₈₃	R ₈₂	R ₈₁	R ₈₀

Figure 21 Data Control Registers (DCD, DCR)

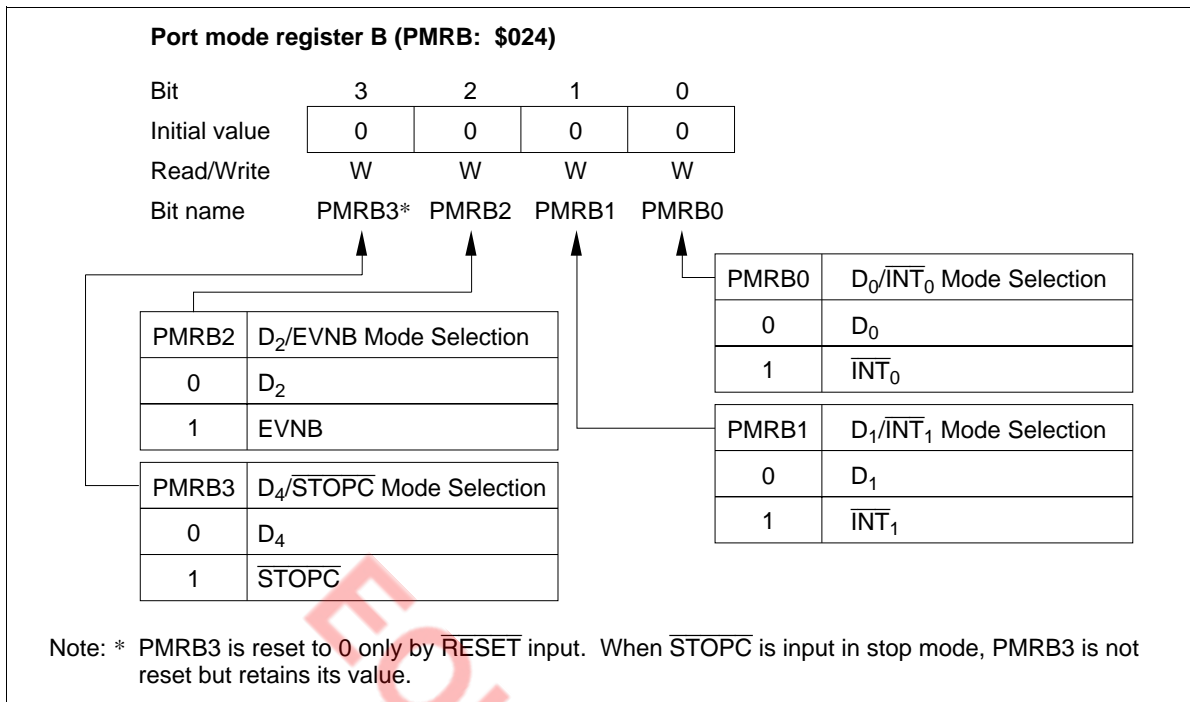

Figure 22 Port Mode Register B (PMRB)

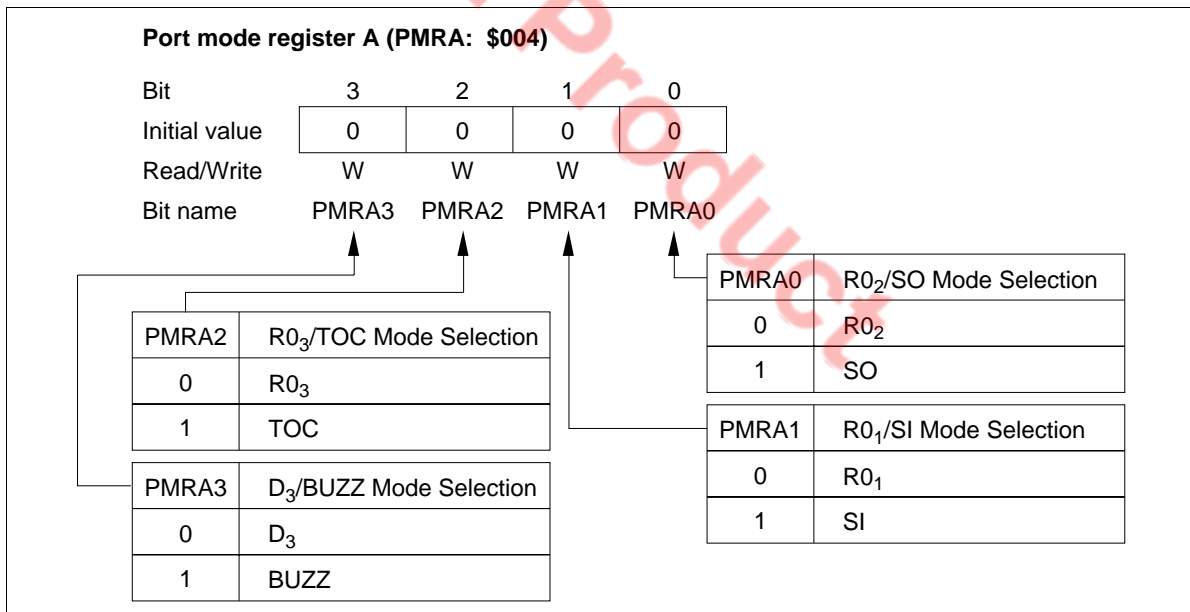

Figure 23 Port Mode Register A (PMRA)

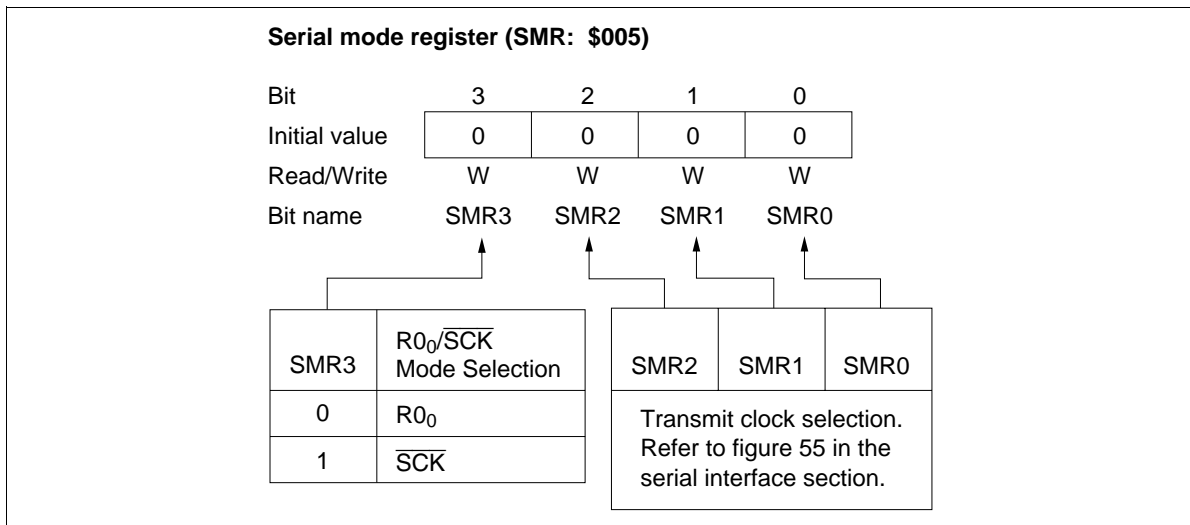

Figure 24 Serial Mode Register (SMR)

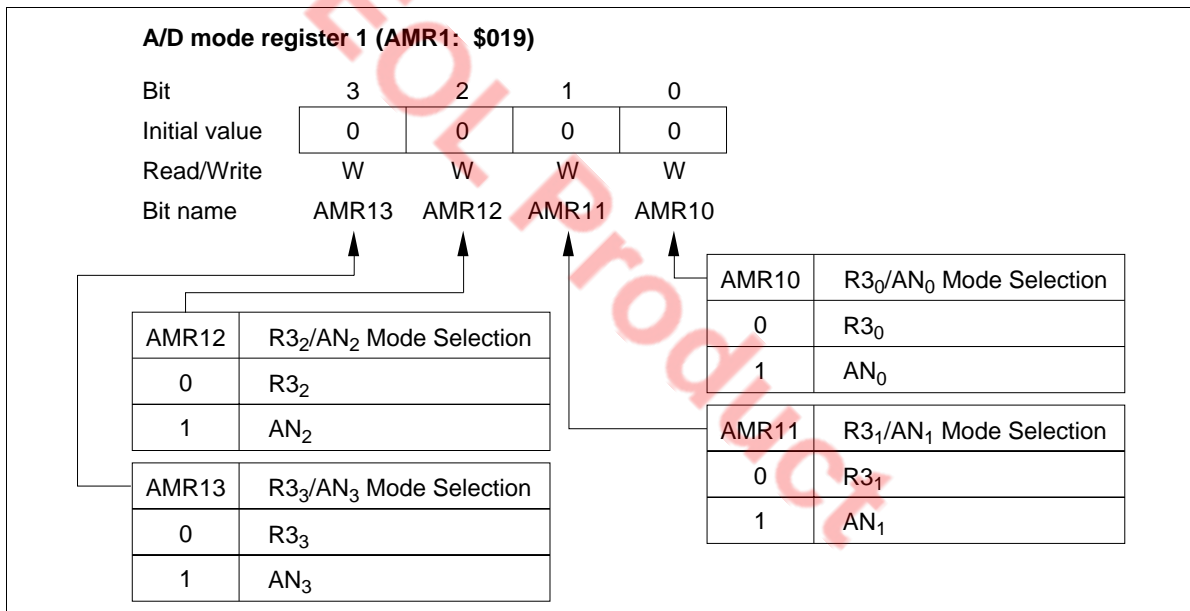

Figure 25 A/D Mode Register 1 (AMR1)

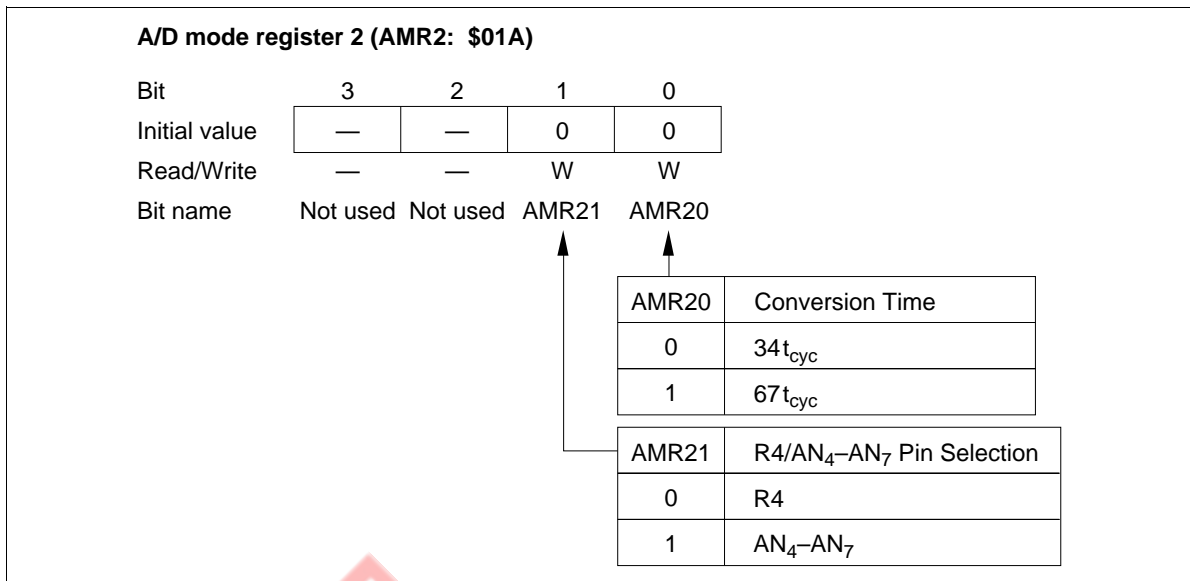

Figure 26 A/D Mode Register 2 (AMR2)

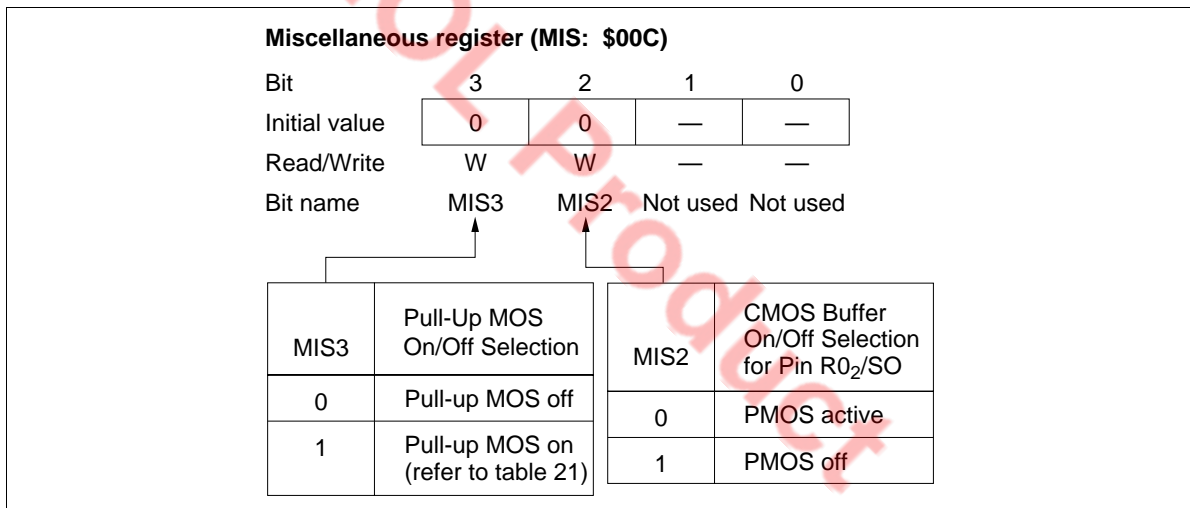

Figure 27 Miscellaneous Register (MIS)

HD40358 Series

Prescalers

The MCU has a built-in prescaler labeled as prescaler S (PSS).

The prescalers operating conditions are listed in table 24, and the prescalers output supply is shown in figure 28. The timers A–C input clocks except external events, the serial transmit clock except the external clock are selected from the prescaler outputs, depending on corresponding mode registers.

Prescaler Operation

Prescaler S: 11-bit counter that inputs the system clock signal. After being reset to \$000 by MCU reset, prescaler S divides the system clock.

Table 24 Prescaler Operating Conditions

Prescaler	Input Clock	Reset Conditions	Stop Conditions
Prescaler S	System clock	MCU reset	MCU reset, stop mode

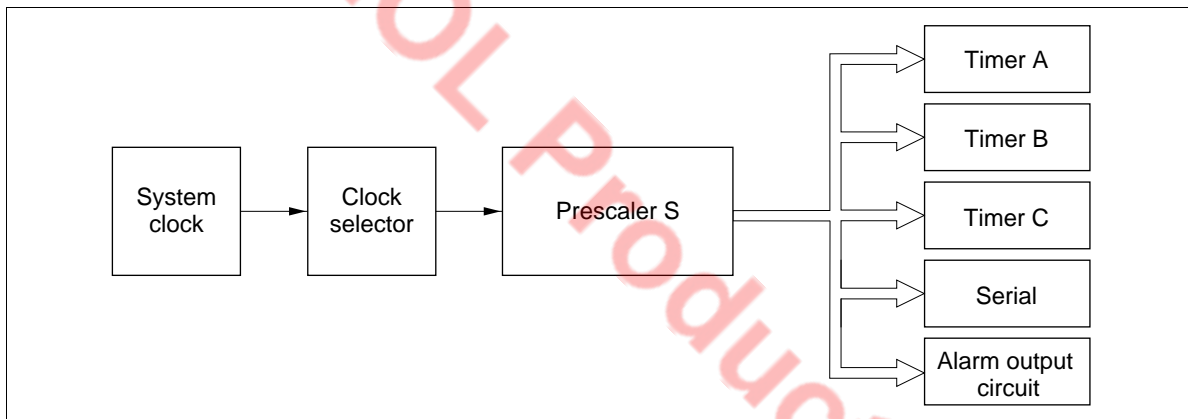

Figure 28 Prescaler Output Supply

Timers

The MCU has four timer/counters (A to C).

- Timer A: Free-running timer
- Timer B: Multifunction timer
- Timer C: Multifunction timer

Timer A is an 8-bit free-running timer. Timers B and C are 8-bit multifunction timers, whose functions are listed in table 25. The operating modes are selected by software.

Table 25 Timer Functions

Functions		Timer A	Timer B	Timer C
Clock source	Prescaler S	Available	Available	Available
	External event	—	Available	—
Timer functions	Free-running	Available	Available	Available
	Event counter	—	Available	—
	Reload	—	Available	Available
	Watchdog	—	—	Available
	Input capture	—	Available	—
Timer output	PWM	—	—	Available

Note: — implies not available.

HD404358 Series

Timer A

Timer A Functions: Timer A has the following functions.

- Free-running timer

The block diagram of timer A is shown in figure 29.

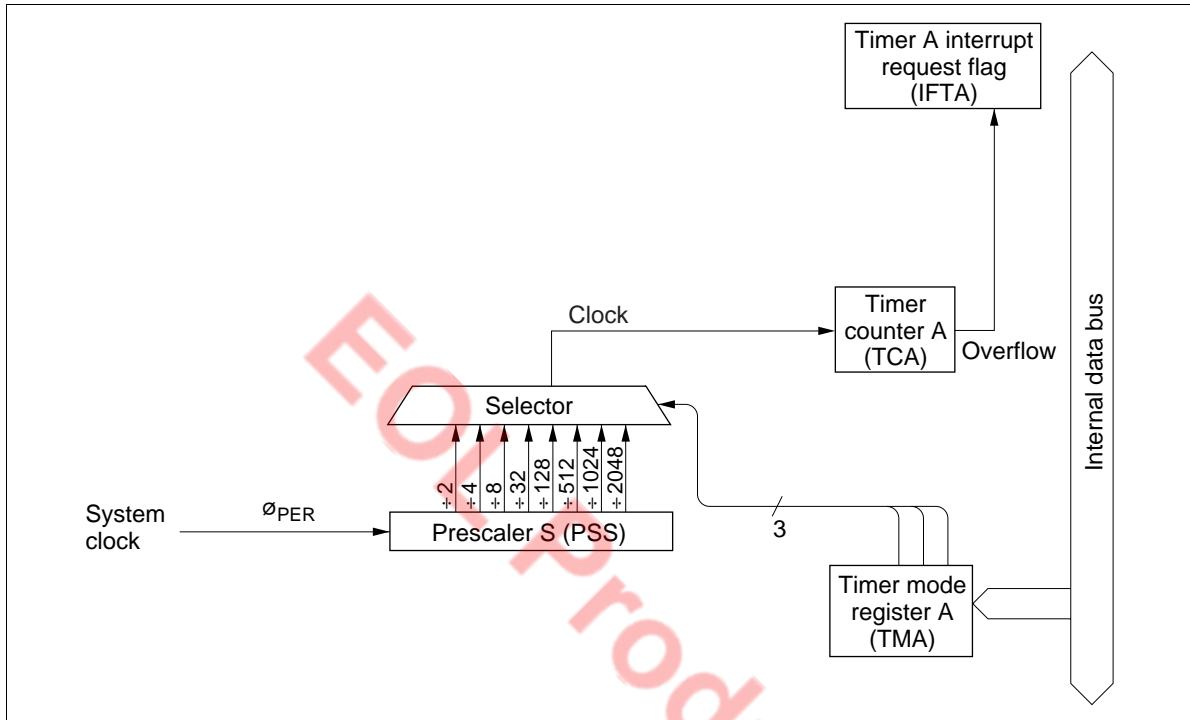

Figure 29 Timer A Block Diagram

Timer A Operations:

- Free-running timer operation: The input clock for timer A is selected by timer mode register A (TMA: \$008).

Timer A is reset to \$00 by MCU reset and incremented at each input clock. If an input clock is applied to timer A after it has reached \$FF, an overflow is generated, and timer A is reset to \$00. The overflow sets the timer A interrupt request flag (IFTA: \$001, bit 2). Timer A continues to be incremented after reset to \$00, and therefore it generates regular interrupts every 256 clocks.

Registers for Timer A Operation: Timer A operating modes are set by the following registers.

- Timer mode register A (TMA: \$008): Four-bit write-only register that selects timer A's operating mode and input clock source as shown in figure 30.

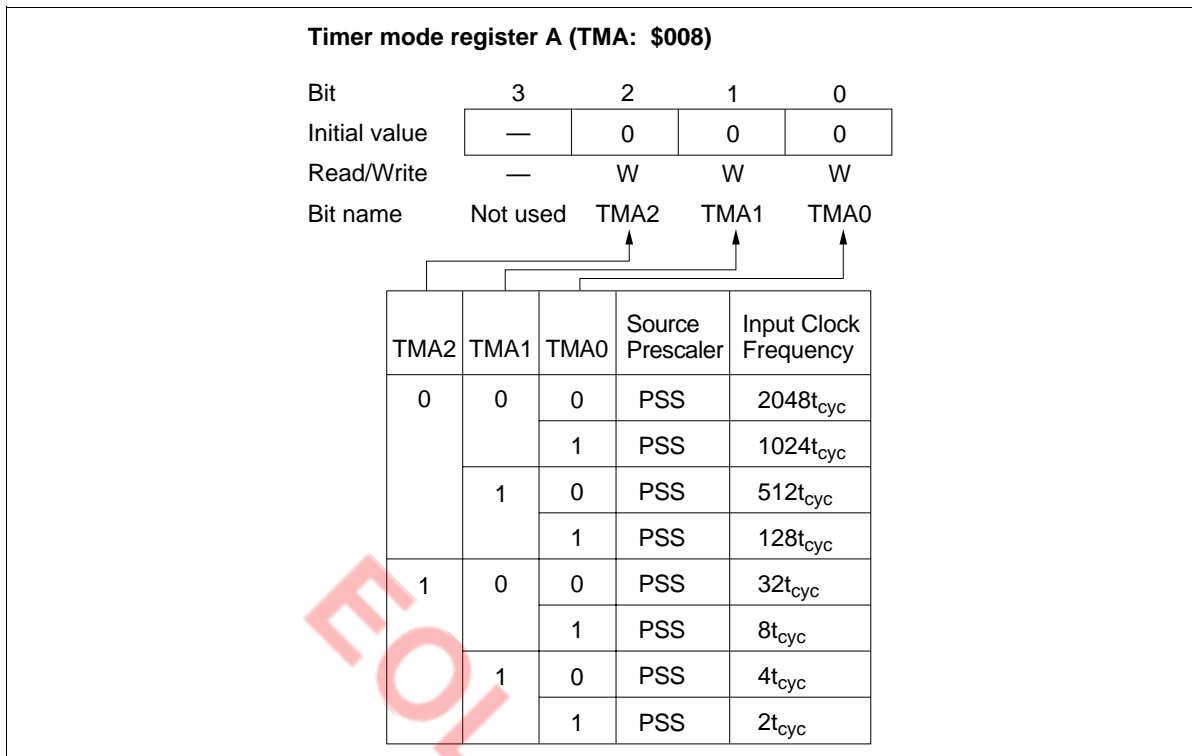

Figure 30 Timer Mode Register A (TMA)

Timer B

Timer B Functions: Timer B has the following functions.

- Free-running/reload timer
- External event counter
- Input capture timer

The block diagram for each operation mode of timer B is shown in figures 31 and 32.

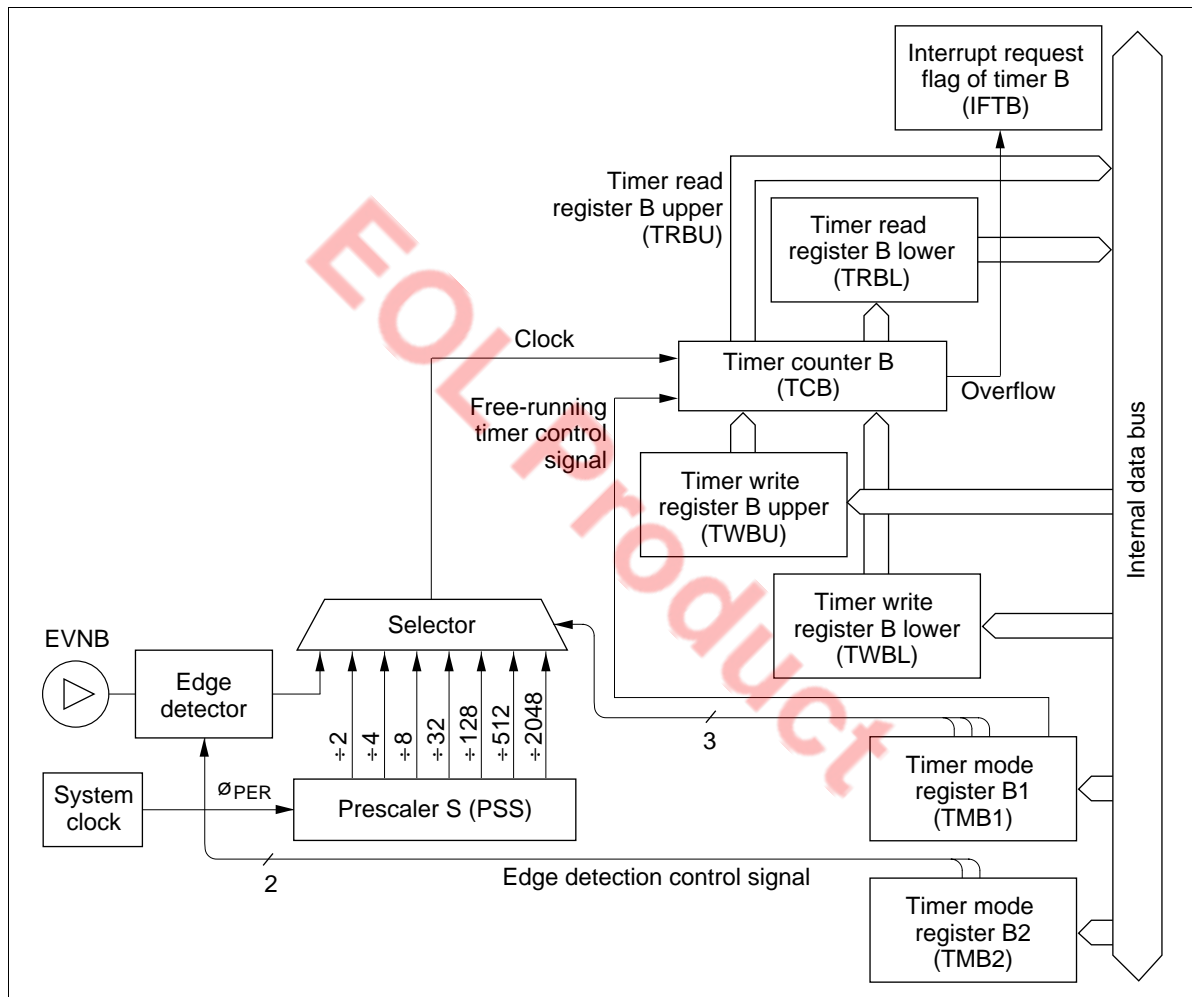

Figure 31 Timer B Free-Running and Reload Operation Block Diagram

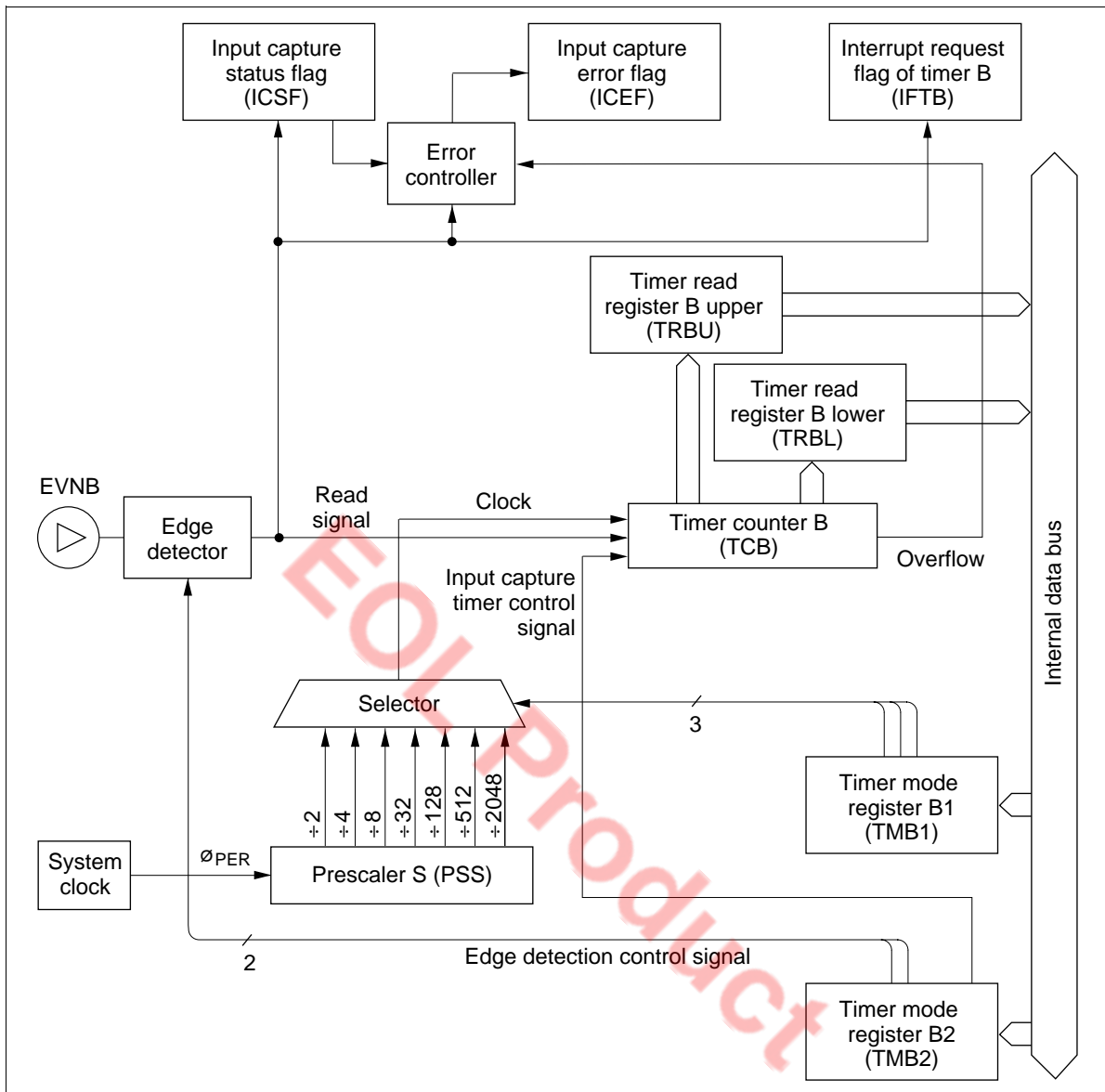

Figure 32 Timer B Input Capture Operation Block Diagram

HD404358 Series

Timer B Operations:

- **Free-running/reload timer operation:** The free-running/reload operation, input clock source, and prescaler division ratio are selected by timer mode register B1 (TMB1: \$009).
Timer B is initialized to the value set in timer write register B (TWBL: \$00A, TWBU: \$00B) by software and incremented by one at each clock input. If an input clock is applied to timer B after it has reached \$FF, an overflow is generated. In this case, if the reload timer function is enabled, timer B is initialized to its initial value set in timer write register B; if the free-running timer function is enabled, the timer is initialized to \$00 and then incremented again.
The overflow sets the timer B interrupt request flag (IFTB: \$002, bit 0). IFTB is reset by software or MCU reset. Refer to figure 3 and table 1 for details.
- **External event counter operation:** Timer B is used as an external event counter by selecting the external event input as an input clock source. In this case, pin D_2 /EVNB must be set to EVNB by port mode register B (PMRB: \$024).
Either falling or rising edge, or both falling and rising edges of input signals can be selected as the external event detection edge by timer mode register 2 (TMB2: \$026). When both rising and falling edges detection is selected, the time between the falling edge and rising edge of input signals must be $2t_{cyc}$ or longer.
Timer B is incremented by one at each detection edge selected by timer mode register 2 (TMB2: \$026). The other operation is basically the same as the free-running/reload timer operation.
- **Input capture timer operation:** The input capture timer counts the clock cycles between trigger edges input to pin EVNB.
Either falling or rising edge, or both falling and rising edges of input signals can be selected as the trigger input edge by timer mode register 2 (TMB2: \$026).
When a trigger edge is input to EVNB, the count of timer B is written to timer read register B (TRBL: \$00A, TRBU: \$00B), and the timer B interrupt request flag (IFTB: \$002, bit 0) and the input capture status flag (ICSF: \$021, bit 0) are set. Timer B is reset to \$00, and then incremented again. While ICSF is set, if a trigger input edge is applied to timer B, or if timer B generates an overflow, the input capture error flag (ICEF: \$021, bit 1) is set. ICSF and ICEF are reset to 0 by MCU reset or by writing 0.

Registers for Timer B Operation: By using the following registers, timer B operation modes are selected and the timer B count is read and written.

Timer mode register B1 (TMB1: \$009)
Timer mode register B2 (TMB2: \$026)
Timer write register B (TWBL: \$00A, TWBU: \$00B)
Timer read register B (TRBL: \$00A, TRBU: \$00B)
Port mode register B (PMRB: \$024)

- **Timer mode register B1 (TMB1: \$009):** Four-bit write-only register that selects the free-running/reload timer function, input clock source, and the prescaler division ratio as shown in figure 33. It is reset to \$0 by MCU reset.

Writing to this register is valid from the second instruction execution cycle after the execution of the previous timer mode register B1 write instruction. Setting timer B's initialization by writing to timer write register B (TWBL: \$00A, TWBU: \$00B) must be done after a mode change becomes valid. When selecting the input capture timer operation, select the internal clock as the input clock source.

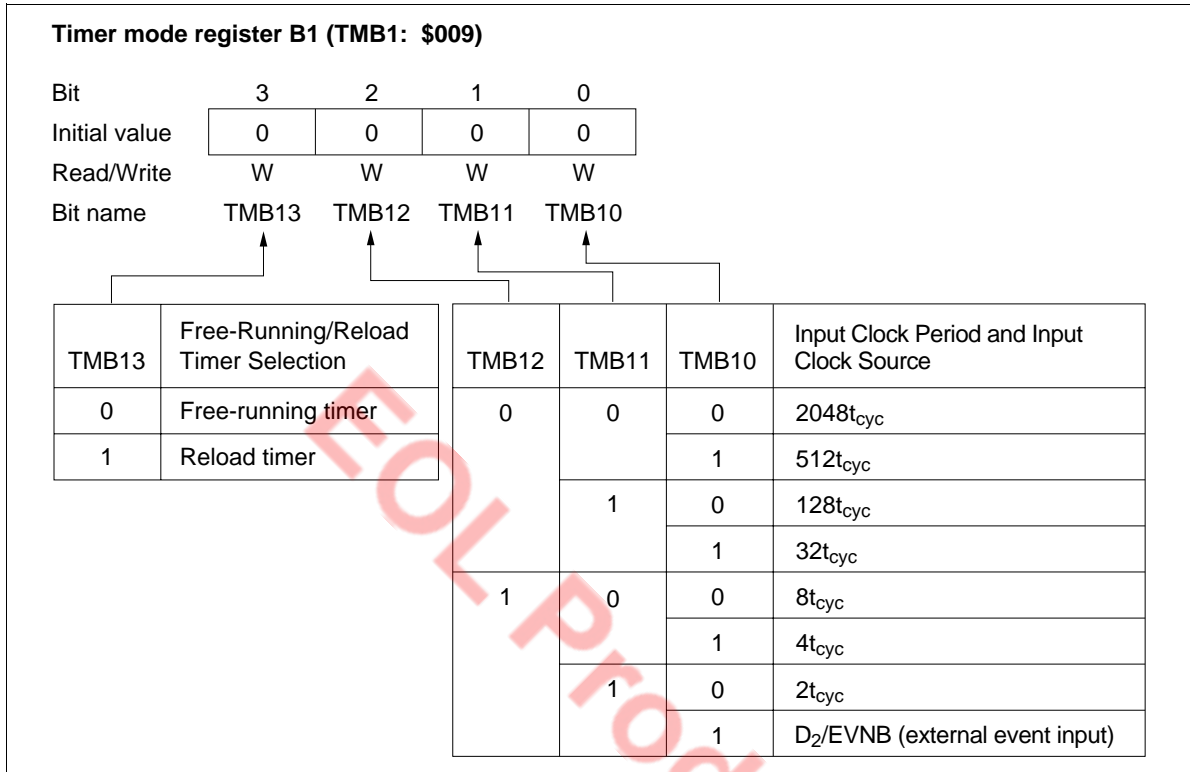

Figure 33 Timer Mode Register B1 (TMB1)

HD404358 Series

- Timer mode register B2 (TMB2: \$026): Three-bit write-only register that selects the detection edge of signals input to pin EVNB and input capture operation as shown in figure 34. It is reset to \$0 by MCU reset.

Timer mode register B2 (TMB2: \$026)				
Bit	3	2	1	0
Initial value	—	0	0	0
Read/Write	—	W	W	W
Bit name	Not used	TMB22	TMB21	TMB20

TMB21	TMB20	EVNB Edge Detection Selection
0	0	No detection
	1	Falling edge detection
1	0	Rising edge detection
	1	Rising and falling edge detection

TMB22	Free-Running/Reload and Input Capture Selection
0	Free-running/reload
1	Input capture

Figure 34 Timer Mode Register B2 (TMB2)

- Timer write register B (TWBL: \$00A, TWBU: \$00B): Write-only register consisting of the lower digit (TWBL) and the upper digit (TWBU). The lower digit is reset to \$0 by MCU reset, but the upper digit value is invalid (figures 35 and 36).

Timer B is initialized by writing to timer write register B (TWBL: \$00A, TWBU: \$00B). In this case, the lower digit (TWBL) must be written to first, but writing only to the lower digit does not change the timer B value. Timer B is initialized to the value in timer write register B at the same time the upper digit (TWBU) is written to. When timer write register B is written to again and if the lower digit value needs no change, writing only to the upper digit initializes timer B.

Timer write register B (lower digit) (TWBL: \$00A)				
Bit	3	2	1	0
Initial value	0	0	0	0
Read/Write	W	W	W	W
Bit name	TWBL3	TWBL2	TWBL1	TWBL0

Figure 35 Timer Write Register B Lower Digit (TWBL)

Timer write register B (upper digit) (TWBU: \$00B)				
Bit	3	2	1	0
Initial value	Undefined	Undefined	Undefined	Undefined
Read/Write	W	W	W	W
Bit name	TWBU3	TWBU2	TWBU1	TWBU0

Figure 36 Timer Write Register B Upper Digit (TWBU)

- Timer read register B (TRBL: \$00A, TRBU: \$00B): Read-only register consisting of the lower digit (TRBL) and the upper digit (TRBU) that holds the count of the timer B upper digit (figures 37 and 38). The upper digit (TRBU) must be read first. At this time, the count of the timer B upper digit is obtained, and the count of the timer B lower digit is latched to the lower digit (TRBL). After this, by reading TRBL, the count of timer B when TRBU is read can be obtained. When the input capture timer operation is selected and if the count of timer B is read after a trigger is input, either the lower or upper digit can be read first.

Timer read register B (lower digit) (TRBL: \$00A)				
Bit	3	2	1	0
Initial value	Undefined	Undefined	Undefined	Undefined
Read/Write	R	R	R	R
Bit name	TRBL3	TRBL2	TRBL1	TRBL0

Figure 37 Timer Read Register B Lower Digit (TRBL)

Timer read register B (upper digit) (TRBU: \$00B)				
Bit	3	2	1	0
Initial value	Undefined	Undefined	Undefined	Undefined
Read/Write	R	R	R	R
Bit name	TRBU3	TRBU2	TRBU1	TRBU0

Figure 38 Timer Read Register B Upper Digit (TRBU)

HD404358 Series

- Port mode register B (PMRB: \$024): Write-only register that selects D₂/EVNB pin function as shown in figure 39. It is reset to \$0 by MCU reset.

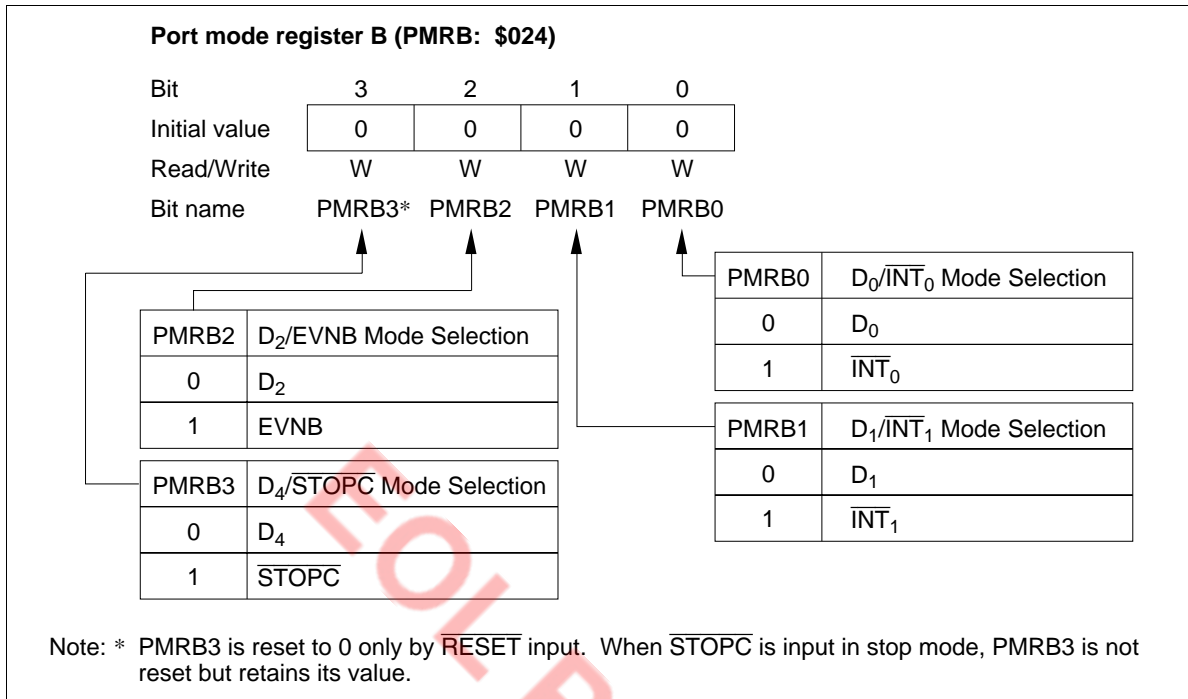

Figure 39 Port Mode Register B (PMRB)

Timer C

Timer C Functions: Timer C has the following functions.

- Free-running/reload timer
- Watchdog timer
- Timer output operation (PWM output)

The block diagram of timer C is shown in figure 40.

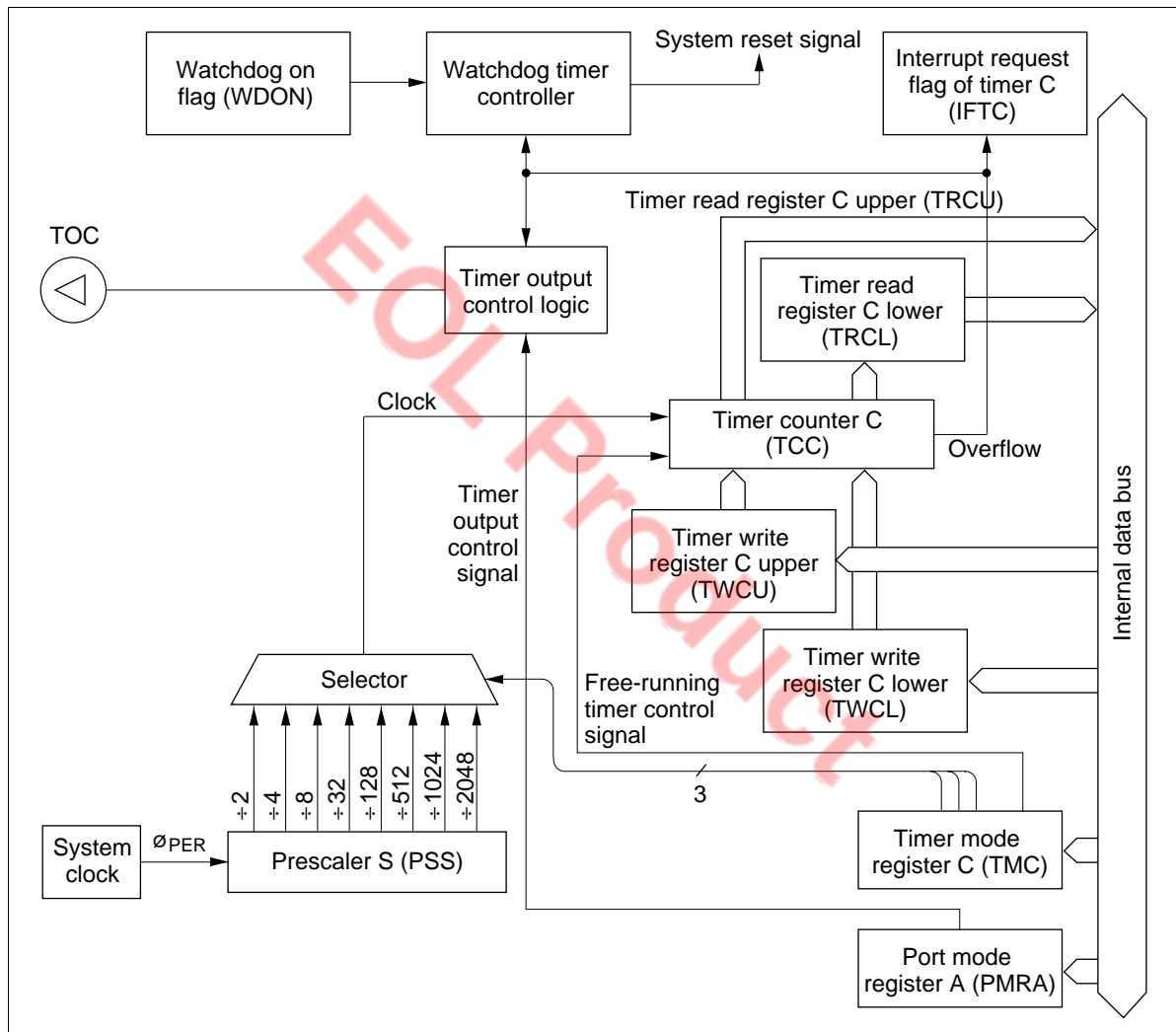

Figure 40 Timer C Block Diagram

HD404358 Series

Timer C Operations:

- Free-running/reload timer operation: The free-running/reload operation, input clock source, and prescaler division ratio are selected by timer mode register C (TMC: \$00D).

Timer C is initialized to the value set in timer write register C (TWCL: \$00E, TWCU: \$00F) by software and incremented by one at each clock input. If an input clock is applied to timer C after it has reached \$FF, an overflow is generated. In this case, if the reload timer function is enabled, timer C is initialized to its initial value set in timer write register C; if the free-running timer function is enabled, the timer is initialized to \$00 and then incremented again.

The overflow sets the timer C interrupt request flag (IFTC: \$002, bit 2). IFTC is reset by software or MCU reset. Refer to figure 3 and table 1 for details.

- Watchdog timer operation: Timer C is used as a watchdog timer for detecting out-of-control program routines by setting the watchdog on flag (WDON: \$020, bit 1) to 1. If a program routine runs out of control and an overflow is generated, the MCU is reset. The watchdog timer operation flowchart is shown in figure 41. Program run can be controlled by initializing timer C by software before it reaches \$FF.

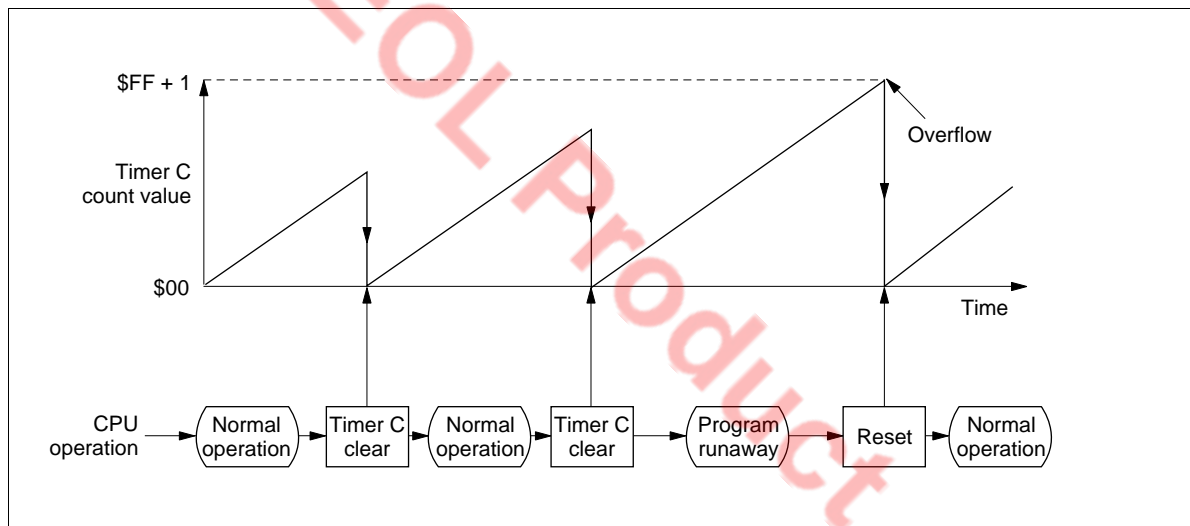

Figure 41 Watchdog Timer Operation Flowchart

- Timer output operation: The PWM output modes can be selected for timer C by setting port mode register A (PMRA: \$004).

By selecting the timer output mode, pin R0₃/TOC is set to TOC. The output from TOC is reset low by MCU reset.

PWM output: When PWM output mode is selected, timer C provides the variable-duty pulse output function. The output waveform differs depending on the contents of timer mode register C (TMC: \$00D) and timer write register C (TWCL: \$00E, TWCU: \$00F). The output waveform is shown in figure 42.

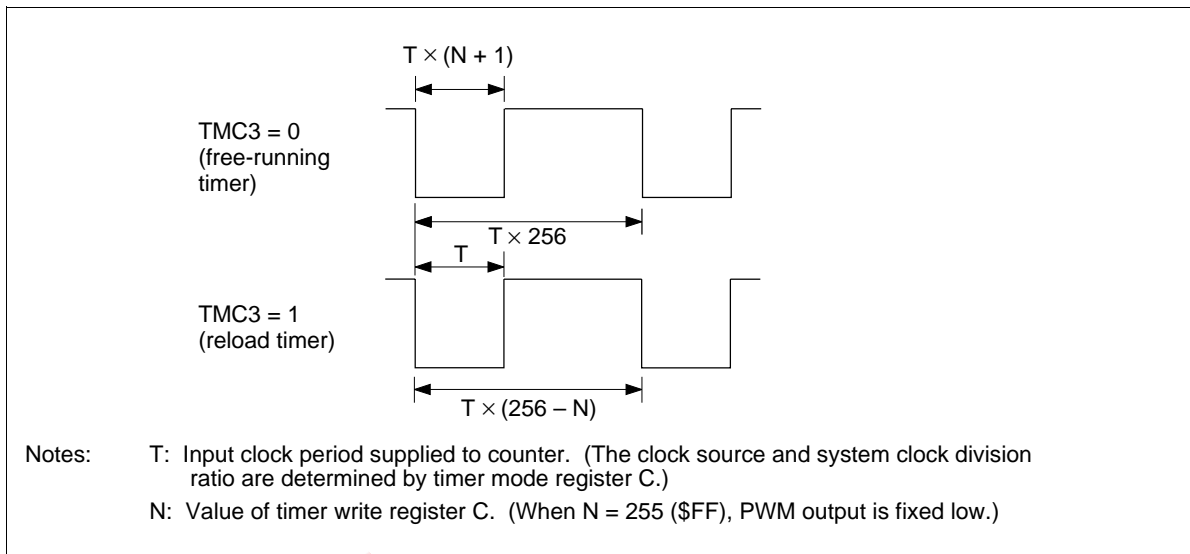

Figure 42 PWM Output Waveform

Notes on Use

When using the timer output as PWM output, note the following point. From the update of the timer write register until the occurrence of the overflow interrupt, the PWM output differs from the period and duty settings, as shown in table 26. The PWM output should therefore not be used until after the overflow interrupt following the update of the timer write register. After the overflow, the PWM output will have the set period and duty cycle.

In this case, the lower digit (TWCL) must be written to first, bit writing only to the lower digit does not change the timer C value. Timer C is changed to the value in timer write register B at the same time the upper digit (TWCU) is written to.

Table 26 PWM Output Following Update of Timer Write Register

PWM Output		
Mode	Timer Write Register is Updated during High PWM Output	Timer Write Register is Updated during Low PWM Output
Reload		

HD404358 Series

Registers for Timer C Operation: By using the following registers, timer C operation modes are selected and the timer C count is read and written.

Timer mode register C (TMC: \$00D)
 Port mode register A (PMRA: \$004)
 Timer write register C (TWCL: \$00E, TWCU: \$00F)
 Timer read register C (TRCL: \$00E, TRCU: \$00F)

- Timer mode register C (TMC: \$00D): Four-bit write-only register that selects the free-running/reload timer function, input clock source, and the prescaler division ratio as shown in figure 43. It is reset to \$0 by MCU reset.

Writing to this register is valid from the second instruction execution cycle after the execution of the previous timer mode register C write instruction. Setting timer C's initialization by writing to timer write register C (TWCL: \$00E, TWCU: \$00F) must be done after a mode change becomes valid.

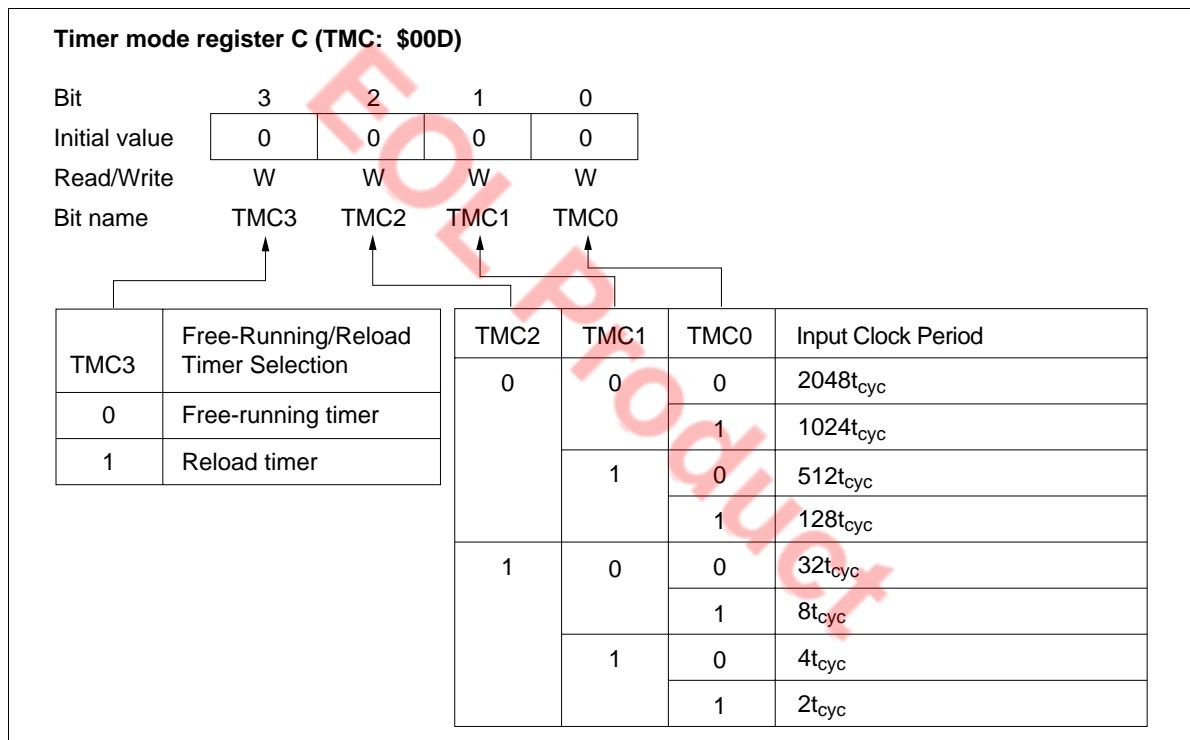

Figure 43 Timer Mode Register C (TMC)

- Port mode register A (PMRA: \$004): Write-only register that selects R0₃/TOC pin function as shown in figure 44. It is reset to \$0 by MCU reset.

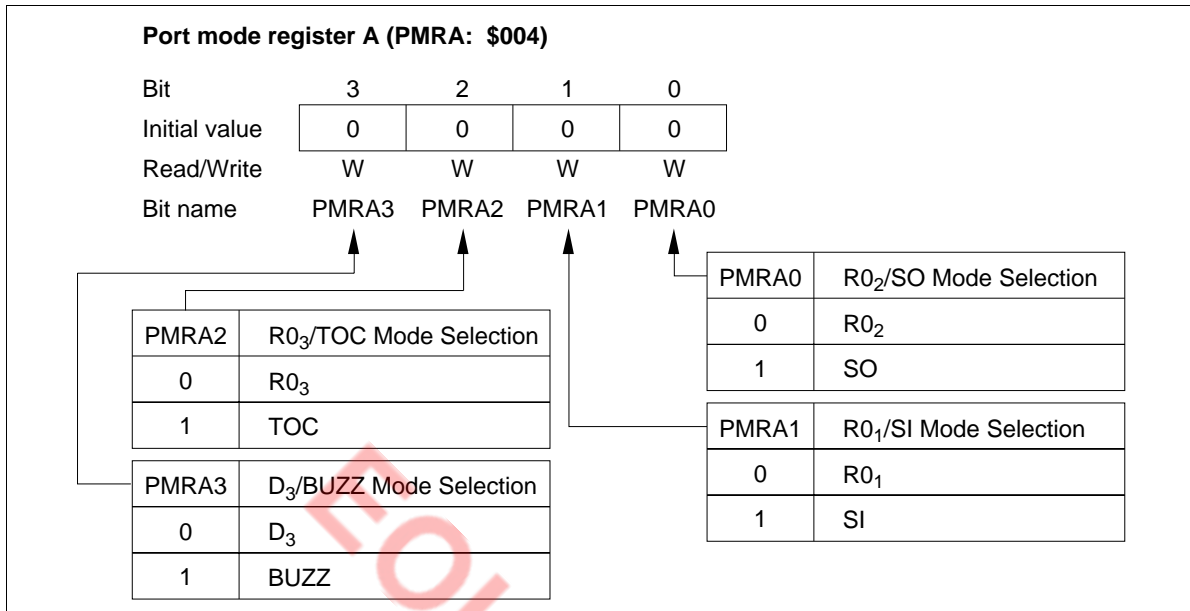

Figure 44 Port Mode Register A (PMRA)

- Timer write register C (TWCL: \$00E, TWCU: \$00F): Write-only register consisting of the lower digit (TWCL) and the upper digit (TWCU) as shown in figures 45 and 46. The operation of timer write register C is basically the same as that of timer write register B (TWBL: \$00A, TWBU: \$00B).

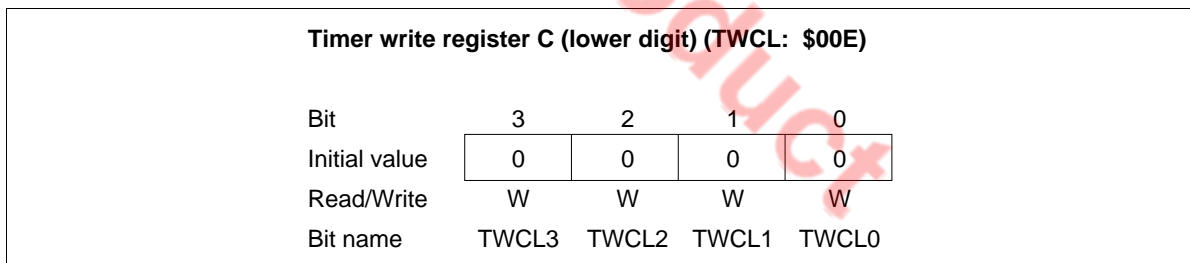

Figure 45 Timer Write Register C Lower Digit (TWCL)

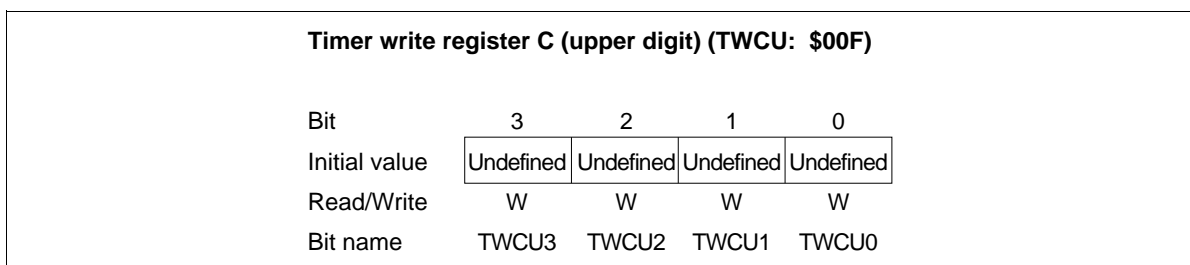

Figure 46 Timer Write Register C Upper Digit (TWCU)

HD404358 Series

- Timer read register C (TRCL: \$00E, TRCU: \$00F): Read-only register consisting of the lower digit (TRCL) and the upper digit (TRCU) that holds the count of the timer C upper digit (figures 47 and 48). The operation of timer read register C is basically the same as that of timer read register B (TRBL: \$00A, TRBU: \$00B).

Timer read register C (lower digit) (TRCL: \$00E)				
Bit	3	2	1	0
Initial value	Undefined	Undefined	Undefined	Undefined
Read/Write	R	R	R	R
Bit name	TRCL3	TRCL2	TRCL1	TRCL0

Figure 47 Timer Read Register C Lower Digit (TRCL)

Timer read register C (upper digit) (TRCU: \$00F)				
Bit	3	2	1	0
Initial value	Undefined	Undefined	Undefined	Undefined
Read/Write	R	R	R	R
Bit name	TRCU3	TRCU2	TRCU1	TRCU0

Figure 48 Timer Read Register C Upper Digit (TRCU)

Alarm Output Function

The MCU has a built-in pulse output function called BUZZ. The pulse frequency can be selected from the prescaler S's outputs, and the output frequency depends on the state of port mode register C (PMRC: \$025). The duty cycle of the pulse output is fixed at 50%.

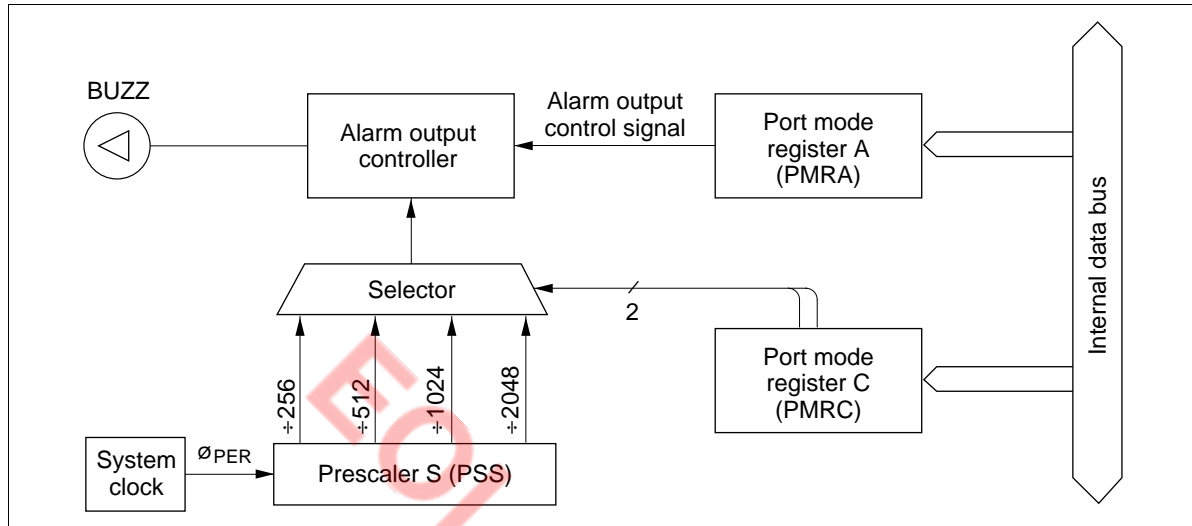

Figure 49 Alarm Output Function Block Diagram

Port Mode Register C (PMRC: \$025): Four-bit write-only register that selects the alarm frequencies as shown in figure 50. It is reset to \$0 by MCU reset.

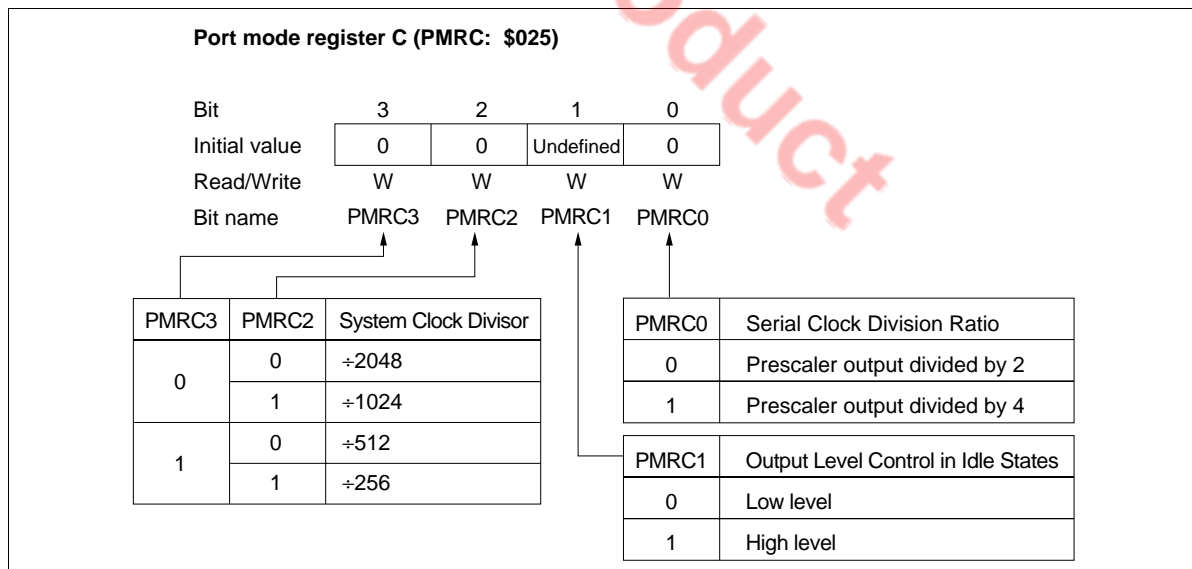

Figure 50 Port Mode Register C (PMRC)

HD404358 Series

Port Mode Register A (PMRA: \$004): Four-bit write-only register that selects D₃/BUZZ pin function as shown in figure 44. It is reset to \$0 by MCU reset.

Serial Interface

The serial interface serially transfers and receives 8-bit data, and includes the following features.

- Multiple transmit clock sources
 - External clock
 - Internal prescaler output clock
 - System clock
- Output level control in idle states

Five registers, an octal counter, and a selector are also configured for the serial interface as follows.

Serial data register (SRL: \$006, SRU: \$007)
Serial mode register (SMR: \$005)
Port mode register A (PMRA: \$004)
Port mode register C (PMRC: \$025)
Miscellaneous register (MIS: \$00C)
Octal counter (OC)
Selector

The block diagram of the serial interface is shown in figure 51.

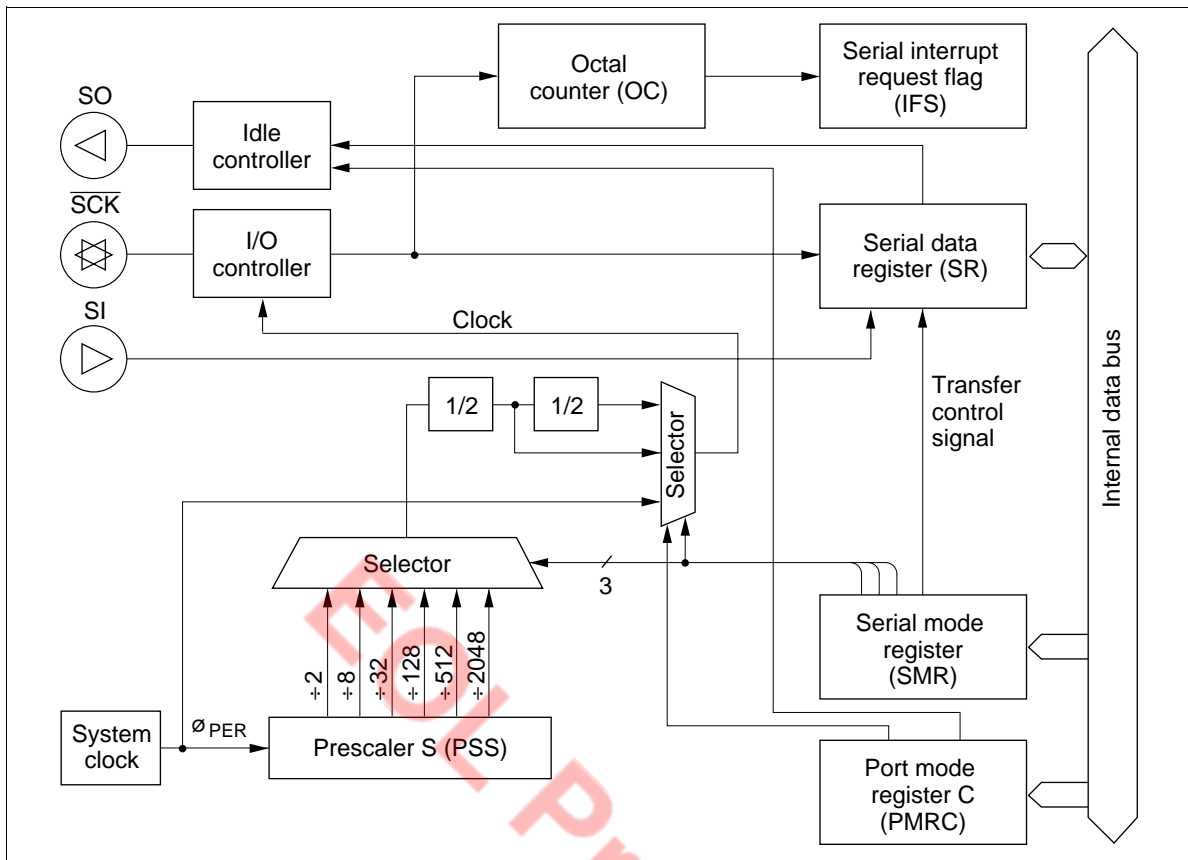

Figure 51 Serial Interface Block Diagram

Serial Interface Operation

Selecting and Changing the Operating Mode: Table 27 lists the serial interface’s operating modes. To select an operating mode, use one of these combinations of port mode register A (PMRA: \$004) and the serial mode register (SMR: \$005) settings; to change the operating mode, always initialize the serial interface internally by writing data to the serial mode register. Note that the serial interface is initialized by writing data to the serial mode register. Refer to the following Serial Mode Register section for details.

Table 27 Serial Interface Operating Modes

SMR		PMRA		Operating Mode
Bit 3	Bit 1	Bit 0		
1	0	0		Continuous clock output mode
		1		Transmit mode
	1	0		Receive mode
		1		Transmit/receive mode

HD404358 Series

Pin Setting: The $R0_0/\overline{SCK}$ pin is controlled by writing data to the serial mode register (SMR: \$005). The $R0_1/SI$ and $R0_2/SO$ pins are controlled by writing data to port mode register A (PMRA: \$004). Refer to the following Registers for Serial Interface section for details.

Transmit Clock Source Setting: The transmit clock source is set by writing data to the serial mode register (SMR: \$005) and port mode register C (PMRC: \$025). Refer to the following Registers for Serial Interface section for details.

Data Setting: Transmit data is set by writing data to the serial data register (SRL: \$006, SRU, \$007). Receive data is obtained by reading the contents of the serial data register. The serial data is shifted by the transmit clock and is input from or output to an external system.

The output level of the SO pin is invalid until the first data is output after MCU reset, or until the output level control in idle states is performed.

Transfer Control: The serial interface is activated by the STS instruction. The octal counter is reset to 000 by this instruction, and it increments at the rising edge of the transmit clock. When the eighth transmit clock signal is input or when serial transmission/receive is discontinued, the octal counter is reset to 000, the serial interrupt request flag (IFS: \$003, bit 2) is set, and the transfer stops.

When the prescaler output is selected as the transmit clock, the transmit clock frequency is selected as $4t_{cyc}$ to $8192t_{cyc}$ by setting bits 0 to 2 (SMR0–SMR2) of serial mode register (SMR: \$005) and bit 0 (PMRC0) of port mode register C (PMRC: \$025) as listed in table 28.

Table 28 Serial Transmit Clock (Prescaler Output)

PMRC		SMR		Prescaler Division Ratio	Transmit Clock Frequency
Bit 0	Bit 2	Bit 1	Bit 0		
0	0	0	0	$\div 2048$	$4096t_{cyc}$
			1	$\div 512$	$1024t_{cyc}$
		1	0	$\div 128$	$256t_{cyc}$
			1	$\div 32$	$64t_{cyc}$
	1	0	0	$\div 8$	$16t_{cyc}$
			1	$\div 2$	$4t_{cyc}$
1	0	0	0	$\div 4096$	$8192t_{cyc}$
			1	$\div 1024$	$2048t_{cyc}$
		1	0	$\div 256$	$512t_{cyc}$
			1	$\div 64$	$128t_{cyc}$
	1	0	0	$\div 16$	$32t_{cyc}$
			1	$\div 4$	$8t_{cyc}$

Operating States: The serial interface has the following operating states; transitions between them are shown in figure 52.

STS wait state
Transmit clock wait state
Transfer state
Continuous clock output state (only in internal clock mode)

- **STS wait state:** The serial interface enters STS wait state by MCU reset (00, 10 in figure 59). In STS wait state, the serial interface is initialized and the transmit clock is ignored. If the STS instruction is then executed (01, 11), the serial interface enters transmit clock wait state.
- **Transmit clock wait state:** Transmit clock wait state is between the STS execution and the falling edge of the first transmit clock. In transmit clock wait state, input of the transmit clock (02, 12) increments the octal counter, shifts the serial data register, and enters the serial interface in transfer state. However, note that if continuous clock output mode is selected in internal clock mode, the serial interface does not enter transfer state but enters continuous clock output state (17).

The serial interface enters STS wait state by writing data to the serial mode register (SMR: \$005) (04, 14) in transmit clock wait state.

- **Transfer state:** Transfer state is between the falling edge of the first clock and the rising edge of the eighth clock. In transfer state, the input of eight clocks or the execution of the STS instruction sets the octal counter to 000, and the serial interface enters another state. When the STS instruction is executed (05, 15), transmit clock wait state is entered. When eight clocks are input, transmit clock wait state is entered (03) in external clock mode, and STS wait state is entered (13) in internal clock mode. In internal clock mode, the transmit clock stops after outputting eight clocks.

In transfer state, writing data to the serial mode register (SMR: \$005) (06, 16) initializes the serial interface, and STS wait state is entered.

If the state changes from transfer to another state, the serial interrupt request flag (IFS: \$003, bit 2) is set by the octal counter that is reset to 000.

- **Continuous clock output state (only in internal clock mode):** Continuous clock output state is entered only in internal clock mode. In this state, the serial interface does not transmit/receive data but only outputs the transmit clock from the \overline{SCK} pin.

When bits 0 and 1 (PMRA0, PMRA1) of port mode register A (PMRA: \$004) are 00 in transmit clock wait state and if the transmit clock is input (17), the serial interface enters continuous clock output state. If the serial mode register (SMR: \$005) is written to in continuous clock output mode (18), STS wait state is entered.

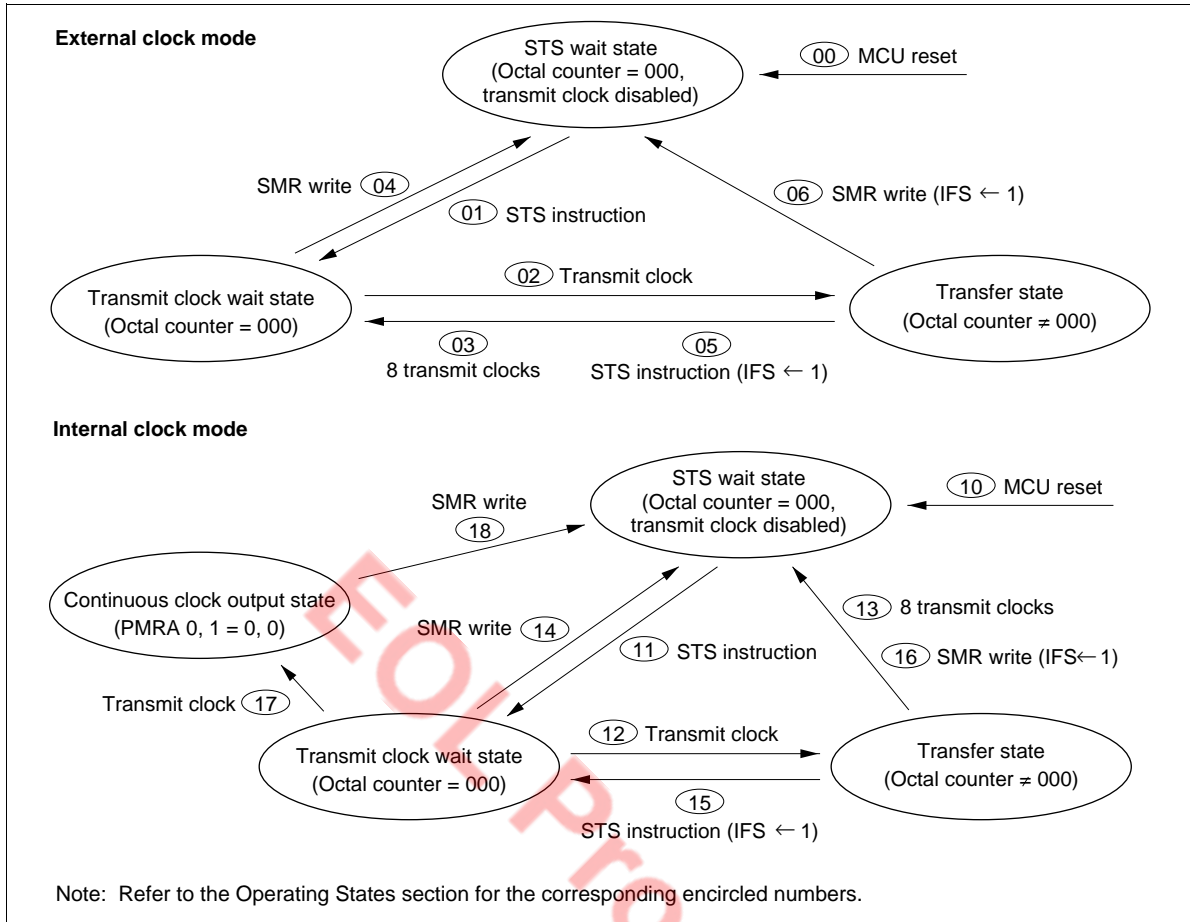

Figure 52 Serial Interface State Transitions

Output Level Control in Idle States: In idle states, that is, STS wait state and transmit clock wait state, the output level of the SO pin can be controlled by setting bit 1 (PMRC1) of port mode register C (PMRC: \$025) to 0 or 1. The output level control example is shown in figure 53. Note that the output level cannot be controlled in transfer state.

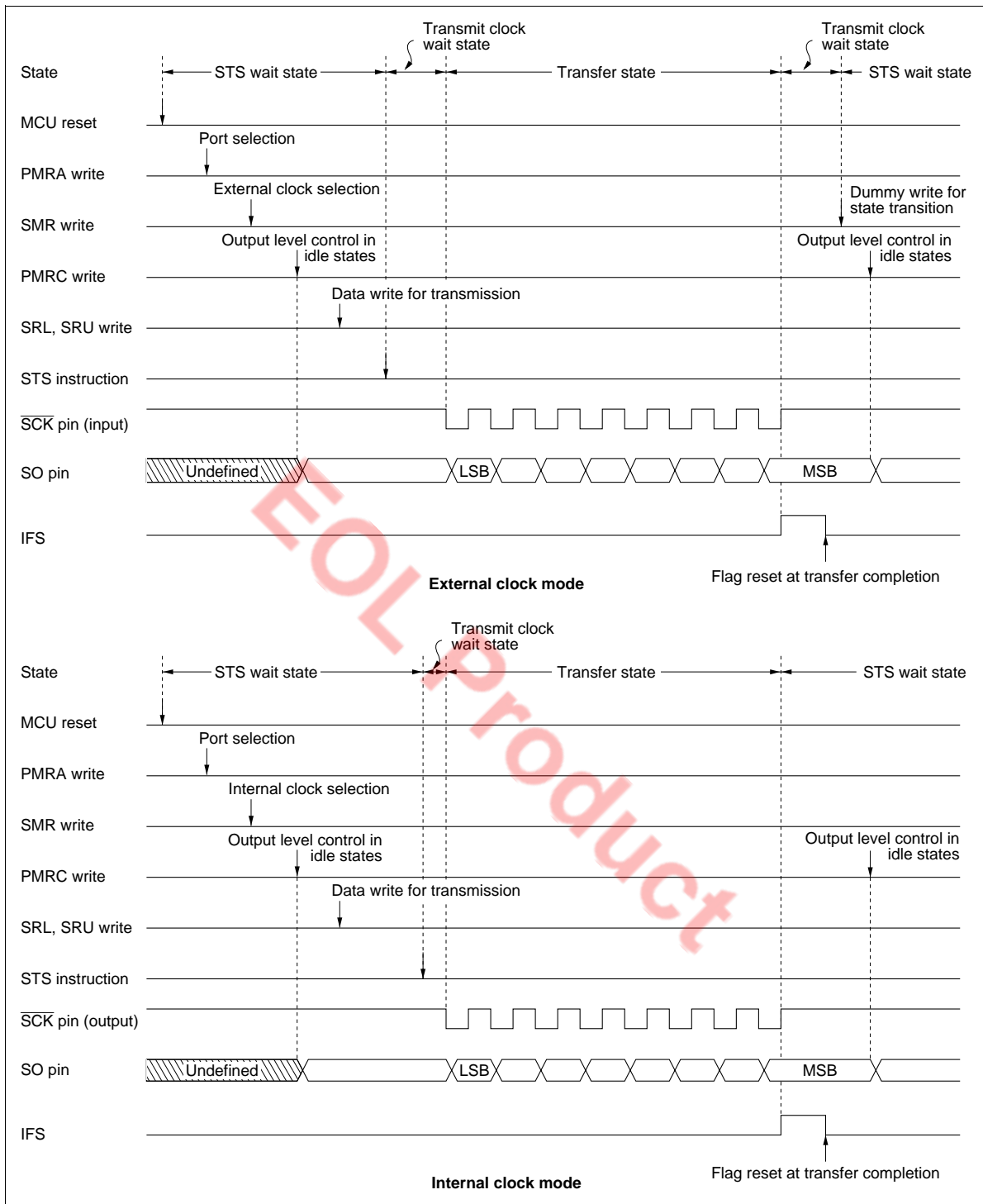

Figure 53 Example of Serial Interface Operation Sequence

HD404358 Series

Transmit Clock Error Detection (In External Clock Mode): The serial interface will malfunction if a spurious pulse caused by external noise conflicts with a normal transmit clock during transfer. A transmit clock error of this type can be detected as shown in figure 54.

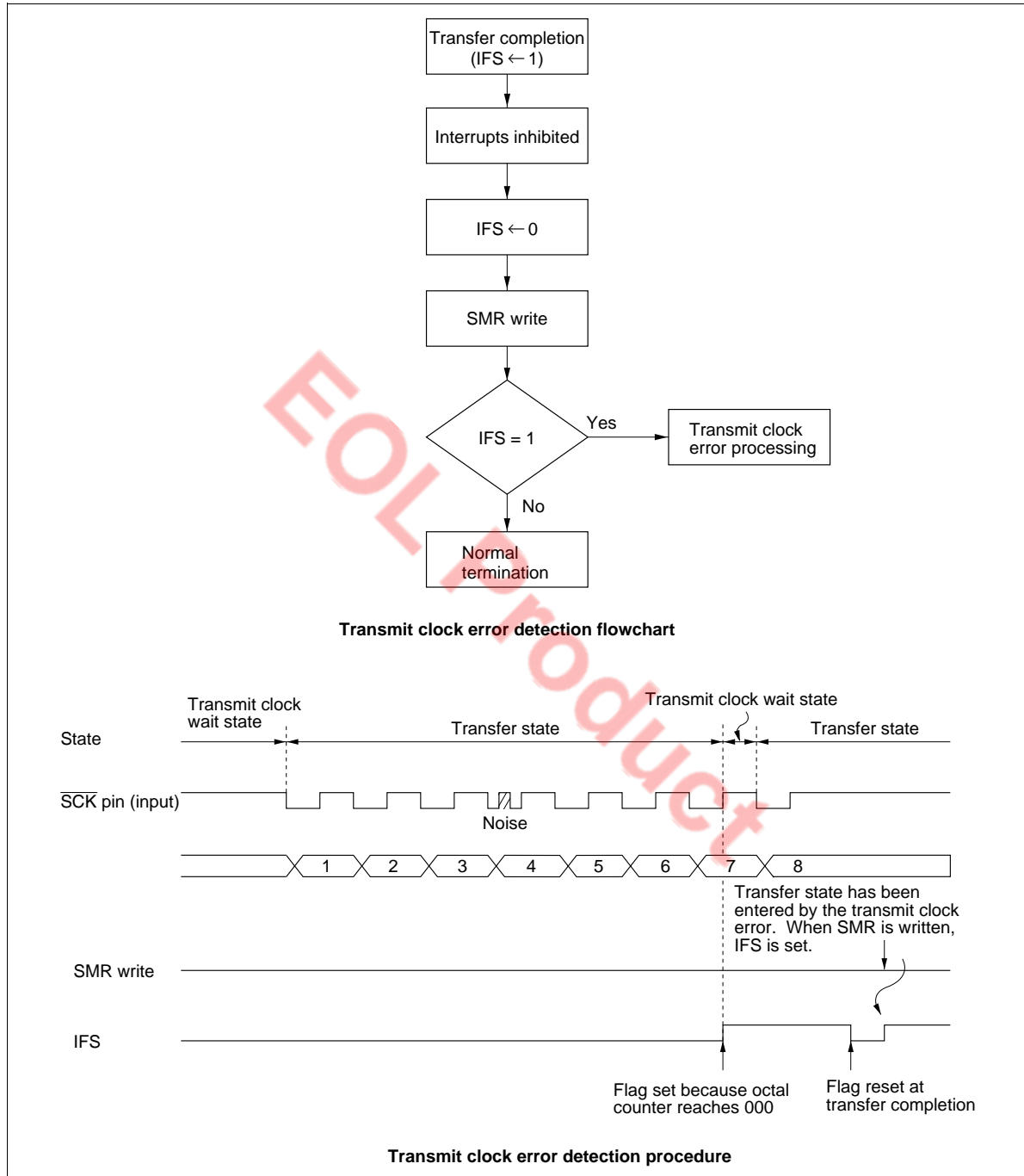

Figure 54 Transmit Clock Error Detection

If more than eight transmit clocks are input in transfer state, at the eighth clock including a spurious pulse by noise, the octal counter reaches 000, the serial interrupt request flag (IFS: \$003, bit 2) is set, and transmit clock wait state is entered. At the falling edge of the next normal clock signal, the transfer state is entered. After the transfer completion processing is performed and IFS is reset, writing to the serial mode register (SMR: \$005) changes the state from transfer to STS wait. At this time IFS is set again, and therefore the error can be detected.

Notes on Use:

- Initialization after writing to registers: If port mode register A (PMRA: \$004) is written to in transmit clock wait state or in transfer state, the serial interface must be initialized by writing to the serial mode register (SMR: \$005) again.
- Serial interrupt request flag (IFS: \$003, bit 2) set: If the state is changed from transfer to another by writing to the serial mode register (SMR: \$005) or executing the STS instruction during the first low pulse of the transmit clock, the serial interrupt request flag is not set. To set the serial interrupt request flag, serial mode register write or STS instruction execution must be programmed to be executed after confirming that the $\overline{\text{SCK}}$ pin is at 1, that is, after executing the input instruction to port R0.

Registers for Serial Interface

The serial interface operation is selected, and serial data is read and written by the following registers.

Serial Mode Register (SMR: \$005)
Serial Data Register (SRL: \$006, SRU: \$007)
Port Mode Register A (PMRA: \$004)
Port Mode Register C (PMRC: \$025)
Miscellaneous Register (MIS: \$00C)

Serial Mode Register (SMR: \$005): This register has the following functions (figure 55).

- $\text{R0}_0/\overline{\text{SCK}}$ pin function selection
- Transmit clock selection
- Prescaler division ratio selection
- Serial interface initialization

Serial mode register (SMR: \$005) is a 4-bit write-only register. It is reset to \$0 by MCU reset.

A write signal input to serial mode register (SMR: \$005) discontinues the input of the transmit clock to the serial data register and octal counter, and the octal counter is reset to 000. Therefore, if a write is performed during data transfer, the serial interrupt request flag (IFS: \$003, bit 2) is set.

Written data is valid from the second instruction execution cycle after the write operation, so the STS instruction must be executed at least two cycles after that.

HD404358 Series

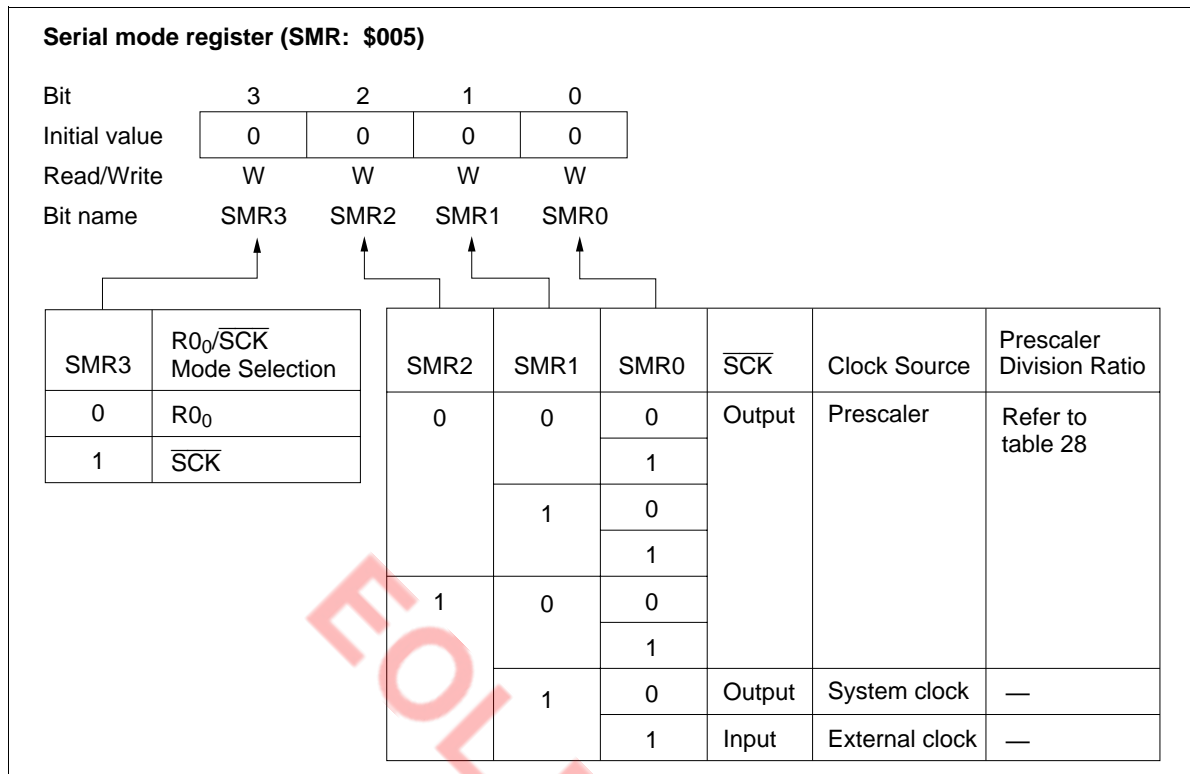

Figure 55 Serial Mode Register (SMR)

Port Mode Register C (PMRC: \$025): This register has the following functions (figure 56).

- Prescaler division ratio selection
- Output level control in idle states

Port mode register C (PMRC: \$025) is a 4-bit write-only register. It cannot be written during data transfer.

By setting bit 0 (PMRC0) of this register, the prescaler division ratio is selected. Bit 0 (PMRC0) can be reset to 0 by MCU reset. By setting bit 1 (PMRC1), the output level of the SO pin is controlled in idle states. The output level changes at the same time that PMRC1 is written to.

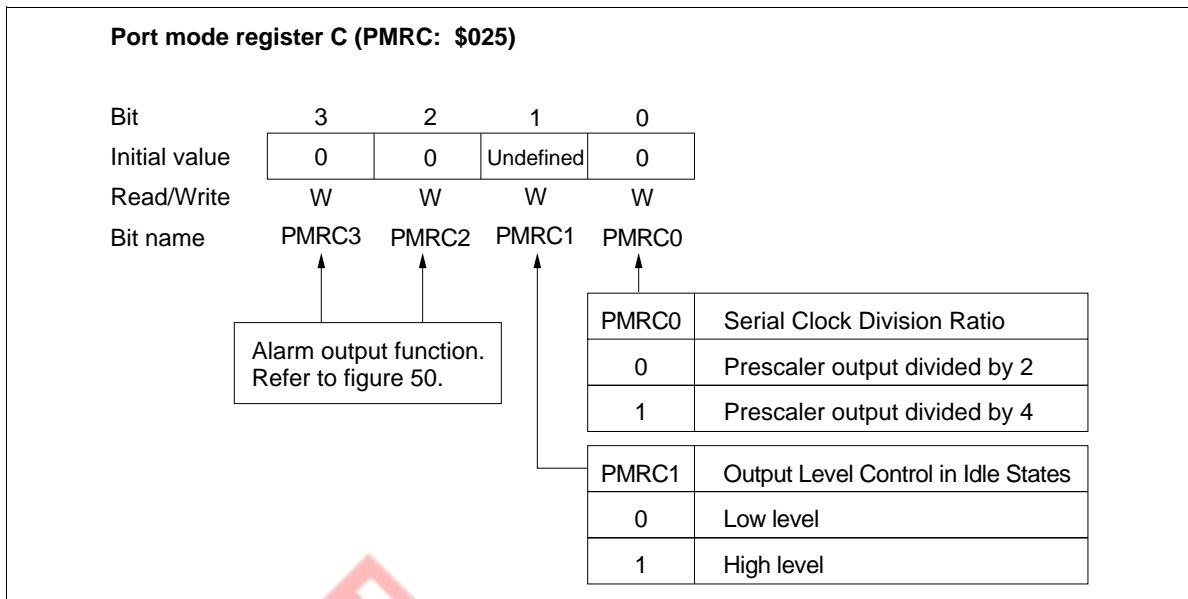

Figure 56 Port Mode Register C (PMRC)

Serial Data Register (SRL: \$006, SRU: \$007): This register has the following functions (figures 57 and 58).

- Transmission data write and shift
- Receive data shift and read

Writing data in this register is output from the SO pin, LSB first, synchronously with the falling edge of the transmit clock; data is input, LSB first, through the SI pin at the rising edge of the transmit clock. Input/output timing is shown in figure 59.

Data cannot be read or written during serial data transfer. If a read/write occurs during transfer, the accuracy of the resultant data cannot be guaranteed.

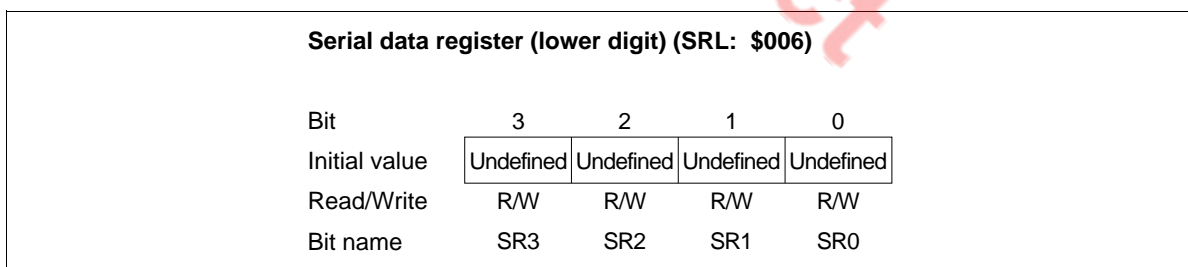

Figure 57 Serial Data Register (SRL)

HD404358 Series

Serial data register (upper digit) (SRU: \$007)				
Bit	3	2	1	0
Initial value	Undefined	Undefined	Undefined	Undefined
Read/Write	R/W	R/W	R/W	R/W
Bit name	SR7	SR6	SR5	SR4

Figure 58 Serial Data Register (SRU)

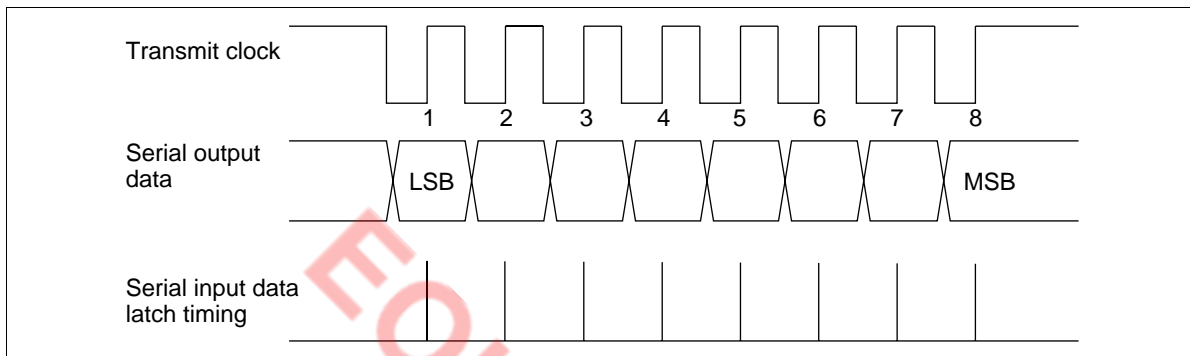

Figure 59 Serial Interface Output Timing

Port Mode Register A (PMRA: \$004): This register has the following functions (figure 60).

- R0₁/SI pin function selection
- R0₂/SO pin function selection

Port mode register A (PMRA: \$004) is a 4-bit write-only register, and is reset to \$0 by MCU reset.

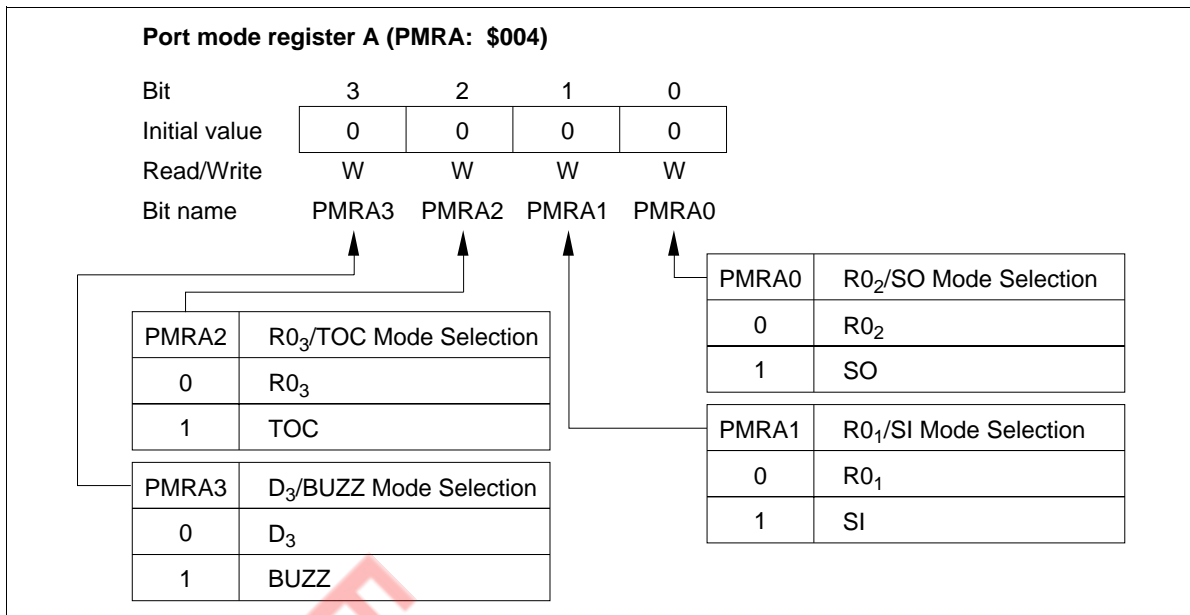

Figure 60 Port Mode Register A (PMRA)

Miscellaneous Register (MIS: \$00C): This register has the following functions (figure 61).

- R0₂/SO pin PMOS control

Miscellaneous register (MIS: \$00C) is a 4-bit write-only register and is reset to \$0 by MCU reset.

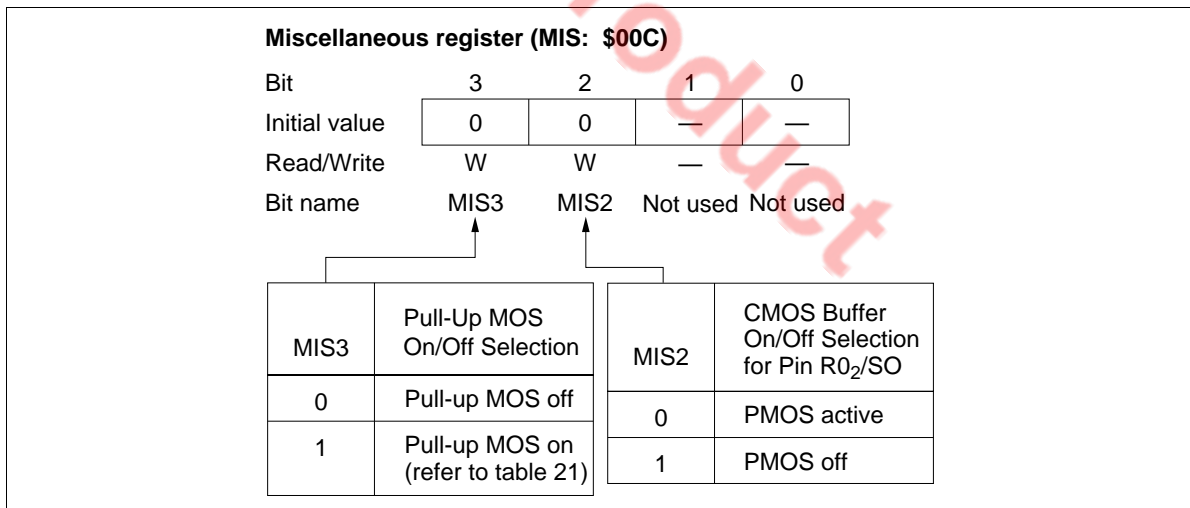

Figure 61 Miscellaneous Register (MIS)

A/D Converter

The MCU has a built-in A/D converter that uses a sequential comparison method with a resistor ladder. It can measure eight analog inputs with 8-bit resolution. The block diagram of the A/D converter is shown in figure 62.

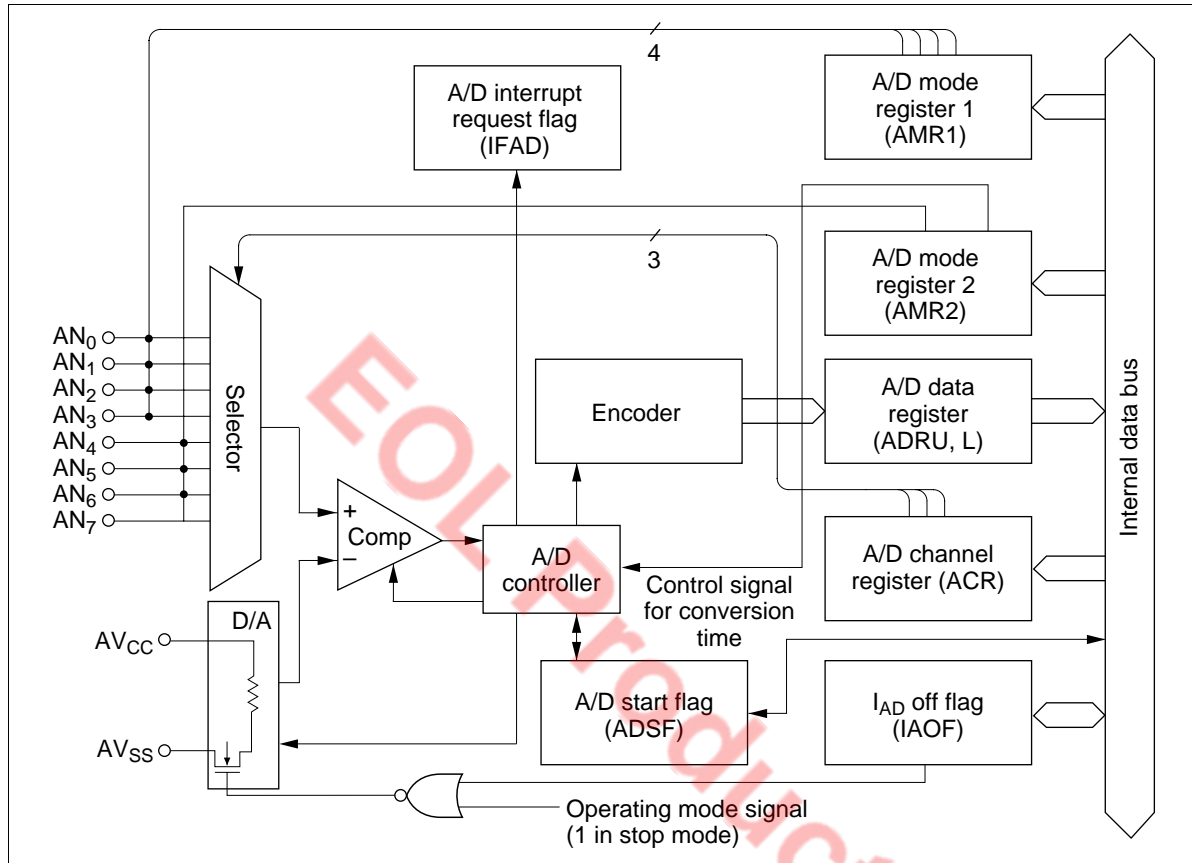

Figure 62 A/D Converter Block Diagram

Registers for A/D Converter Operation

A/D Mode Register 1 (AMR1: \$019): Four-bit write-only register which selects digital or analog ports, as shown in figure 63.

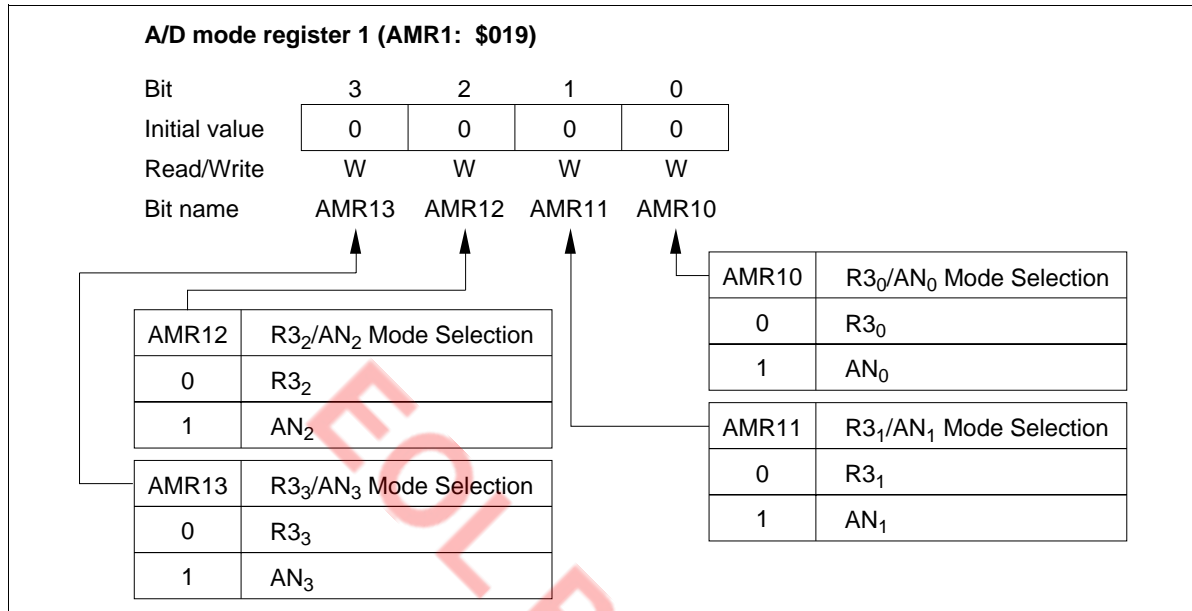

Figure 63 A/D Mode Register 1 (AMR1)

A/D Mode register 2 (AMR2: \$01A): Two-bit write-only register which is used to set the A/D conversion period and to select digital or analog ports. Bit 0 of the A/D mode register selects the A/D conversion period, and bit 1 selects port R4 as pins AN₄–AN₇ in 4-pin units (figure 64).

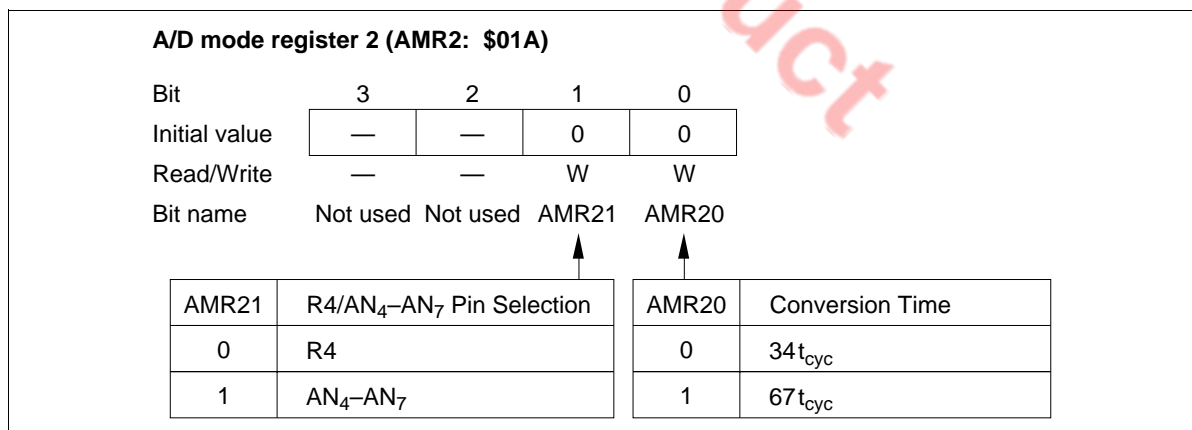

Figure 64 A/D Mode Register 2 (AMR2)

HD404358 Series

A/D Channel Register (ACR: \$016): Three-bit write-only register which indicates analog input pin information, as shown in figure 65.

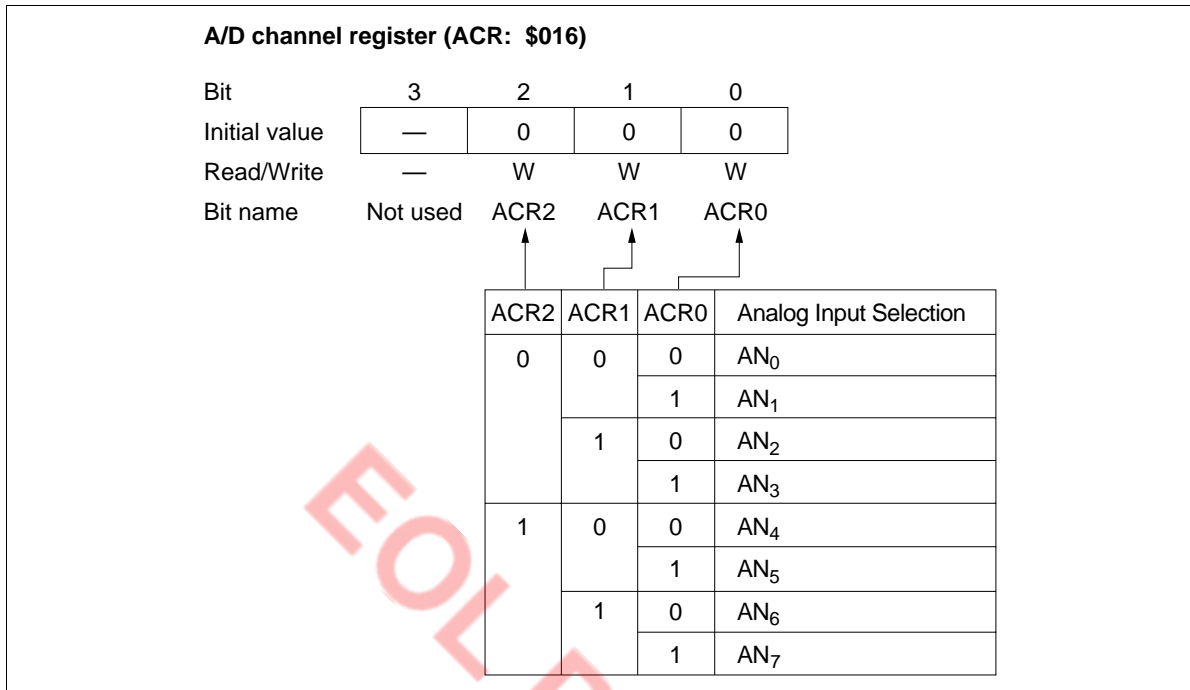

Figure 65 A/D Channel Register (ACR)

A/D Start Flag (ADSF: \$02C, Bit 2): One-bit flag that initiates A/D conversion when set to 1. At the completion of A/D conversion, the converted data is stored in the A/D data register and the A/D start flag is cleared. Refer to figure 66.

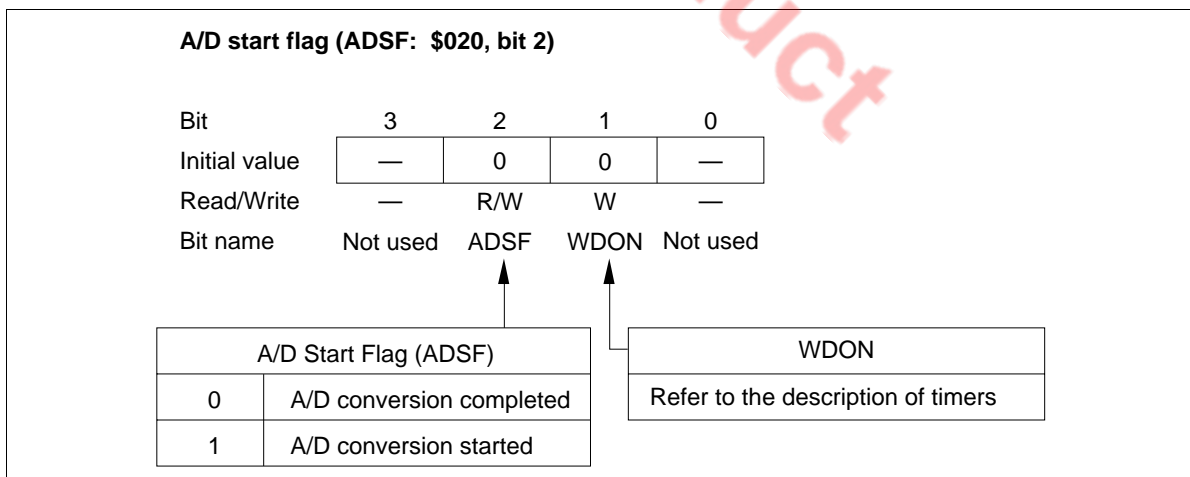

Figure 66 A/D Start Flag (ADSF)

I_{AD} Off Flag (IAOF: \$021, Bit 2): By setting the I_{AD} off flag to 1, the current flowing through the resistance ladder can be cut off even while operating in standby or active mode, as shown in figure 67.

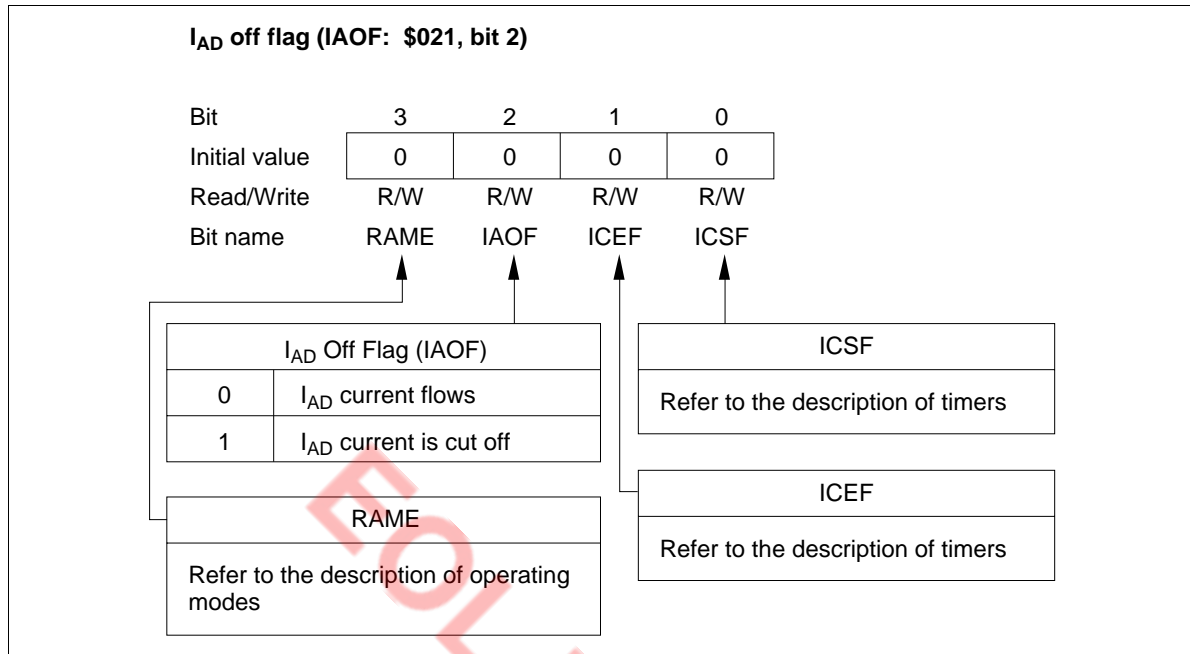

Figure 67 I_{AD} Off Flag (IAOF)

A/D Data Register (ADRL: \$017, ADRU: \$018): Eight-bit read-only register consisting of a 4-bit lower digit and 4-bit upper digit. This register is not cleared by reset. After the completion of A/D conversion, the resultant eight-bit data is held in this register until the start of the next conversion (figures 68, 69, and 70).

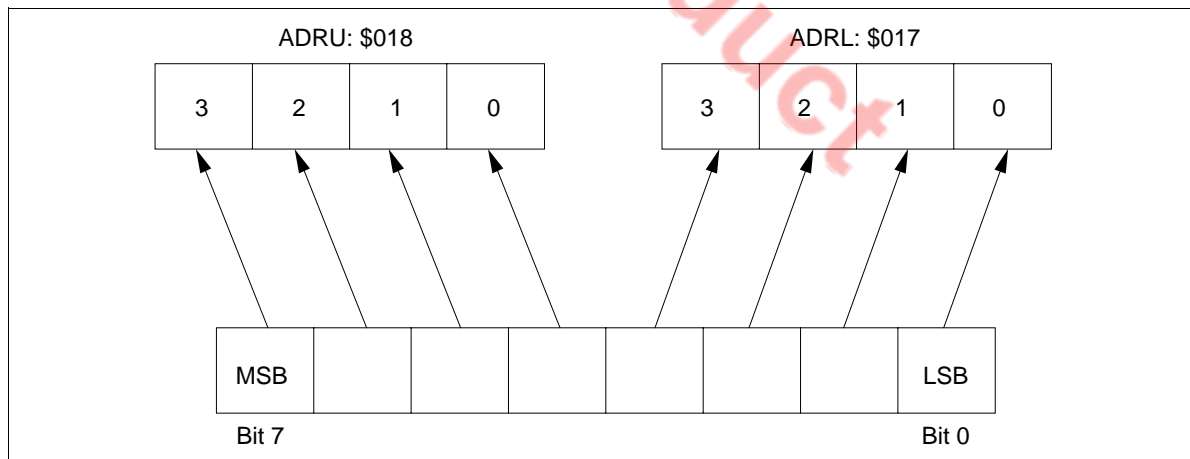

Figure 68 A/D Data Registers (ADRU, ADRL)

HD404358 Series

A/D data register (lower digit) (ADRL: \$017)

Bit	3	2	1	0
Initial value	0	0	0	0
Read/Write	R	R	R	R
Bit name	ADRL3	ADRL2	ADRL1	ADRL0

Figure 69 A/D Data Register Lower Digit (ADRL)

A/D data register (upper digit) (ADRU: \$018)

Bit	3	2	1	0
Initial value	1	0	0	0
Read/Write	R	R	R	R
Bit name	ADRU3	ADRU2	ADRU1	ADRU0

Figure 70 A/D Data Register Upper Digit (ADRU)

Notes on Usage

- Use the SEM or SEMD instruction for writing to the A/D start flag (ADSF)
- Do not write to the A/D start flag during A/D conversion
- Data in the A/D data register during A/D conversion is undefined
- Since the operation of the A/D converter is based on the clock from the system oscillator, the A/D converter does not operate in stop mode. In addition, to save power while in these modes, all current flowing through the converter's resistance ladder is cut off.
- If the power supply for the A/D converter is to be different from V_{CC} , connect a 0.1- μ F bypass capacitor between the AV_{CC} and AV_{SS} pins. (However, this is not necessary when the AV_{CC} pin is directly connected to the V_{CC} pin.)
- The contents of the A/D data register are not guaranteed during A/D conversion. To ensure that the A/D converter operates stably, do not execute port output instructions during A/D conversion.
- The port data register (PDR) is initialized to 1 by an MCU reset. At this time, if pull-up MOS is selected as active by bit 3 of the miscellaneous register (MIS3), the port will be pulled up to V_{CC} . When using a shared R port/analog input pin as an input pin, clear PDR to 0. Otherwise, if pull-up MOS is selected by MIS3 and PDR is set to 1, a pin selected by A/D mode register 1 or 2 (AMR1 or AMR2) as an analog pin will remain pulled up (figure 71).

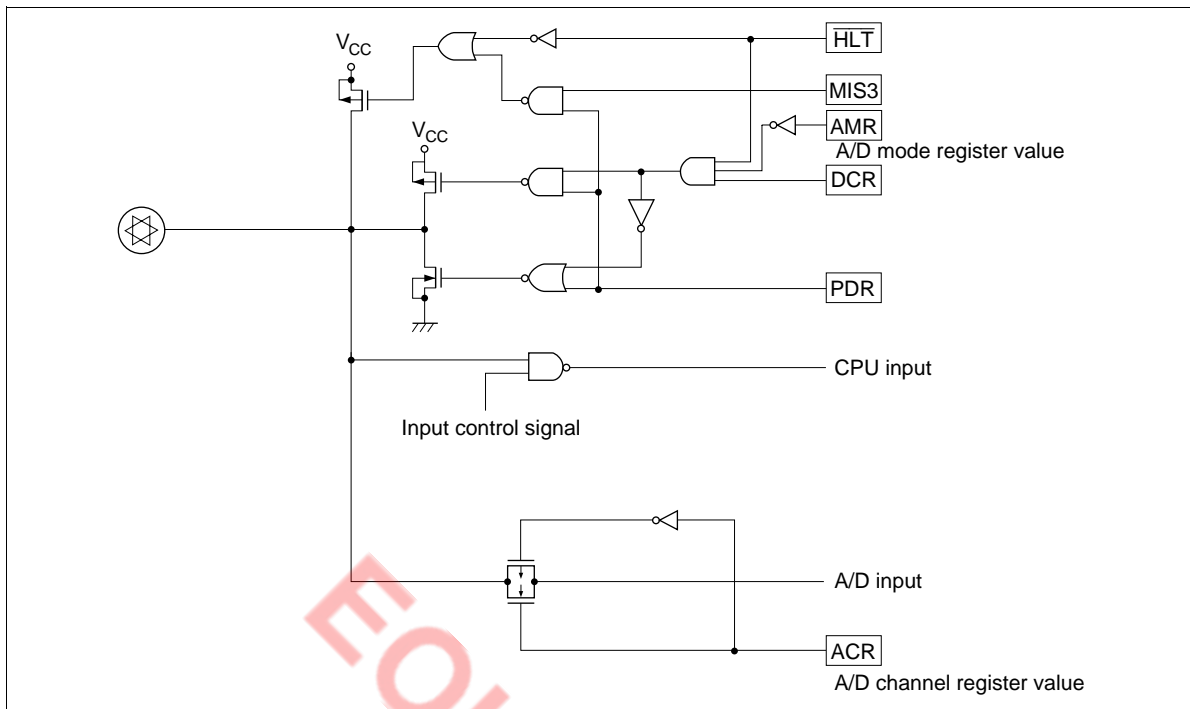

Figure 71 R Port/Analog Multiplexed Pin Circuit

HD404358 Series

Pin Description in PROM Mode

The HD4074359 is a PROM version of a ZTAT™ microcomputer. In PROM mode, the MCU stops operating, thus allowing the user to program the on-chip PROM.

Pin Number		MCU Mode		PROM Mode	
DP-42S	FP-44A	Pin	I/O	Pin	I/O
1	39	RA ₁	I	O ₀	I/O
2	40	R0 ₀ /SCK	I/O	V _{CC}	
3	41	R0 ₁ /SI	I/O	V _{CC}	
4	42	R0 ₂ /SO	I/O	O ₁	I/O
5	43	R0 ₃ /TOC	I/O	O ₂	I/O
6	1	TEST	I	V _{PP}	
7	2	RESET	I	RESET	I
8	3	OSC ₁	I	V _{CC}	
9	4	OSC ₂	O		
10	5	GND		GND	
11	6	AV _{SS}		GND	
12	7	R3 ₀ /AN ₀	I/O	O ₀	I/O
13	8	R3 ₁ /AN ₁	I/O	O ₁	I/O
14	9	R3 ₂ /AN ₂	I/O	O ₂	I/O
15	10	R3 ₃ /AN ₃	I/O	O ₃	I/O
16	11	R4 ₀ /AN ₄	I/O	O ₄	I/O
17	12	R4 ₁ /AN ₅	I/O	M ₀	I
18	13	R4 ₂ /AN ₆	I/O	M ₁	I
19	14	R4 ₃ /AN ₇	I/O		
20	15	AV _{CC}		V _{CC}	
21	16	V _{CC}		V _{CC}	
22	17	D ₀ /INT ₀	I/O	O ₃	I/O
23	18	D ₁ /INT ₁	I/O	O ₄	I/O
24	19	D ₂ /EVNB	I/O	A ₁	I
25	20	D ₃ /BUZZ	I/O	A ₂	I
26	21	D ₄ /STOPC	I/O		
27	23	D ₅	I/O	A ₃	I
28	24	D ₆	I/O	A ₄	I
29	25	D ₇	I/O	A ₉	I
30	26	D ₈	I/O	V _{CC}	

HD404358 Series

Pin Number		MCU Mode		PROM Mode	
DP-42S	FP-44A	Pin	I/O	Pin	I/O
31	27	R8 ₀	I/O	\overline{CE}	I
32	28	R8 ₁	I/O	\overline{OE}	I
33	29	R8 ₂	I/O	A ₁₃	I
34	30	R8 ₃	I/O	A ₁₄	I
35	31	R1 ₀	I/O	A ₅	I
36	32	R1 ₁	I/O	A ₆	I
37	33	R1 ₂	I/O	A ₇	I
38	34	R1 ₃	I/O	A ₈	I
39	35	R2 ₀	I/O	A ₀	I
40	36	R2 ₁	I/O	A ₁₀	I
41	37	R2 ₂	I/O	A ₁₁	I
42	38	R2 ₃	I/O	A ₁₂	I

Notes: 1. I/O: Input/output pin; I: Input pin; O: Output pin

2. O₀ to O₄ consist of two pins each. The each pair together before using them.

HD404358 Series

Programming the Built-In PROM

The MCU's built-in PROM is programmed in PROM mode. PROM mode is set by pulling $\overline{\text{RESET}}$, $\overline{\text{M}}_0$, and $\overline{\text{M}}_1$ low, as shown in figure 72. In PROM mode, the MCU does not operate, but it can be programmed in the same way as any other commercial 27256-type EPROM using a standard PROM programmer and a 100-to-28-pin socket adapter. Recommended PROM programmers and socket adapters are listed in table 29.

Since an HMCS400-series instruction is ten bits long, the HMCS400-series MCU has a built-in conversion circuit to enable the use of a general-purpose PROM programmer. This circuit splits each instruction into five lower bits and five upper bits that are read from or written to consecutive addresses. This means that if, for example, 16 kwords of built-in PROM are to be programmed by a general-purpose PROM programmer, a 32-kbyte address space (\$0000-\$7FFF) must be specified.

Table 29 Recommended PROM Programmers and Socket Adapters

PROM Programmer		Socket Adapter		
Manufacture	Model Name	Package	Manufacture	Model Name
DATA I/O corp	121 B	DP-42S	Hitachi	HS4359ESS01H
		FP-44A		HS4359ESH01H
AVAL corp	PKW-1000	DP-42S	Hitachi	HS4359ESS01H
		FP-44A		HS4359ESH01H

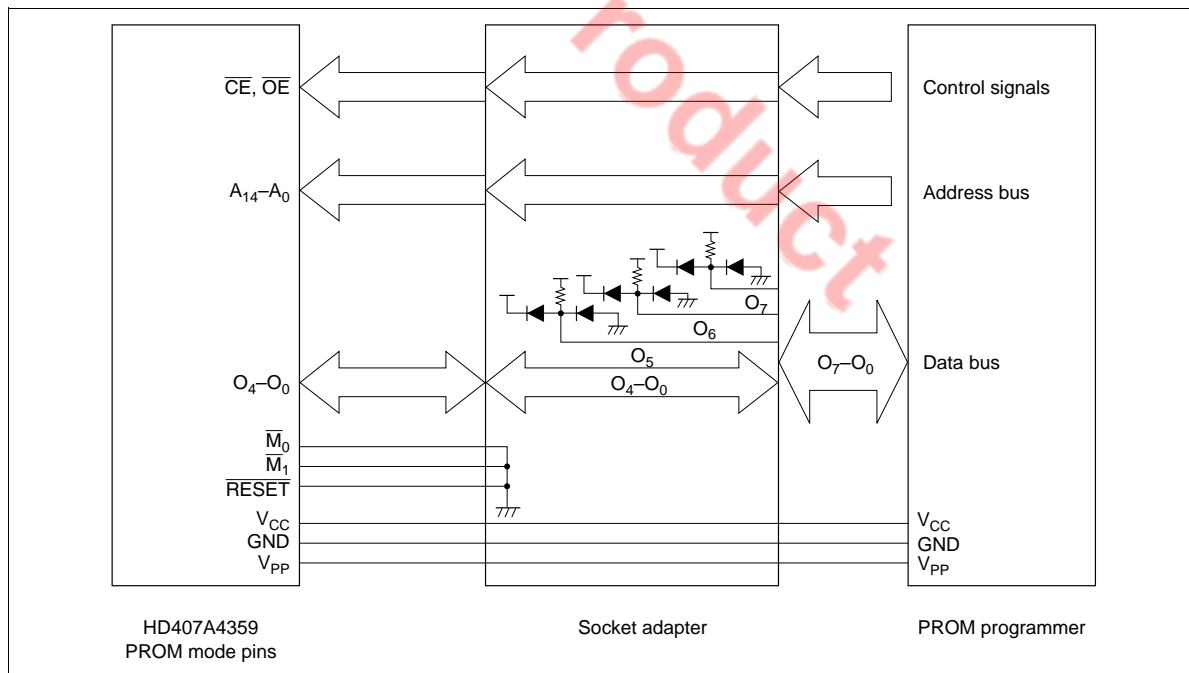

Figure 72 PROM Mode Connections

Warnings

1. Always specify addresses \$0000 to \$7FFF when programming with a PROM programmer. If address \$8000 or higher is accessed, the PROM may not be programmed or verified correctly. Set all data in unused addresses to \$FF.
Note that the plastic-package version cannot be erased and reprogrammed.
2. Make sure that the PROM programmer, socket adapter, and LSI are aligned correctly (their pin 1 positions match), otherwise overcurrents may damage the LSI. Before starting programming, make sure that the LSI is firmly fixed in the socket adapter and the socket adapter is firmly fixed onto the programmer.
3. PROM programmers have two voltages (V_{pp}): 12.5 V and 21 V. Remember that ZTAT™ devices require a V_{pp} of 12.5 V—the 21-V setting will damage them. 12.5 V is the Intel 27256 setting.

Programming and Verification

The built-in PROM of the MCU can be programmed at high speed without risk of voltage stress or damage to data reliability.

Programming and verification modes are selected as listed in table 30.

For details of PROM programming, refer to the following Notes on PROM Programming section.

Table 30 PROM Mode Selection

Mode	Pin			
	\overline{CE}	\overline{OE}	V_{pp}	O_0-O_4
Programming	Low	High	V_{pp}	Data input
Verification	High	Low	V_{pp}	Data output
Programming inhibited	High	High	V_{pp}	High impedance

Addressing Modes

RAM Addressing Modes

The MCU has three RAM addressing modes, as shown in figure 73 and described below.

Register Indirect Addressing Mode: The contents of the W, X, and Y registers (10 bits in total) are used as a RAM address.

Direct Addressing Mode: A direct addressing instruction consists of two words. The first word contains the opcode, and the contents of the second word (10 bits) are used as a RAM address.

Memory Register Addressing Mode: The memory registers (MR), which are located in 16 addresses from \$040 to \$04F, are accessed with the LAMR and XMRA instructions.

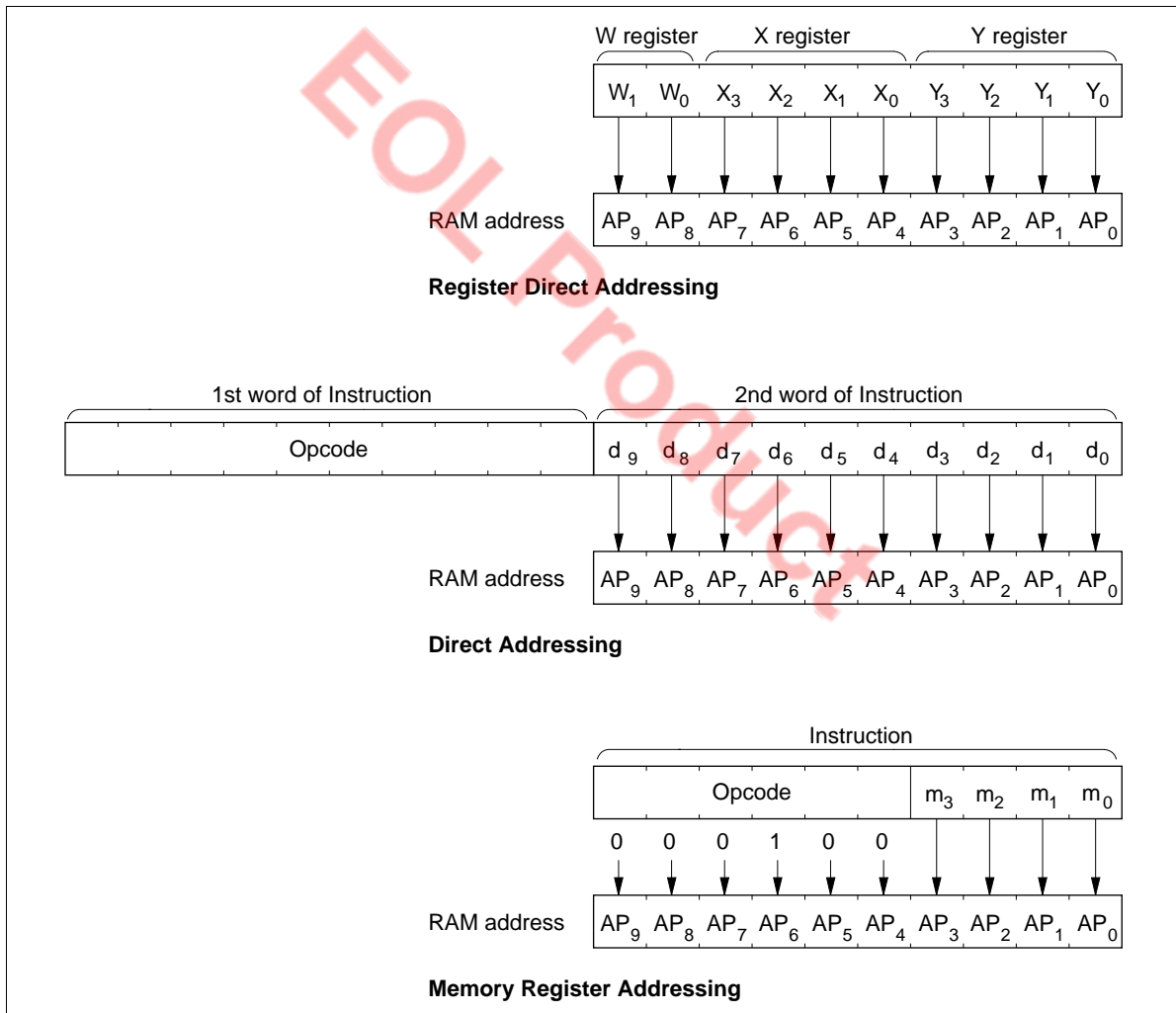

Figure 73 RAM Addressing Modes

ROM Addressing Modes and the P Instruction

The MCU has four ROM addressing modes, as shown in figure 74 and described below.

Direct Addressing Mode: A program can branch to any address in the ROM memory space by executing the JMPL, BRL, or CALL instruction. Each of these instructions replaces the 14 program counter bits (PC_{13} – PC_0) with 14-bit immediate data.

Current Page Addressing Mode: The MCU has 64 pages of ROM with 256 words per page. A program can branch to any address in the current page by executing the BR instruction. This instruction replaces the eight low-order bits of the program counter (PC_7 – PC_0) with eight-bit immediate data. If the BR instruction is on a page boundary (address $256n + 255$), executing that instruction transfers the PC contents to the next physical page, as shown in figure 76. This means that the execution of the BR instruction on a page boundary will make the program branch to the next page.

Note that the HMCS400-series cross macroassembler has an automatic paging feature for ROM pages.

Zero-Page Addressing Mode: A program can branch to the zero-page subroutine area located at \$0000–\$003F by executing the CAL instruction. When the CAL instruction is executed, 6 bits of immediate data are placed in the six low-order bits of the program counter (PC_5 – PC_0), and 0s are placed in the eight high-order bits (PC_{13} – PC_6).

Table Data Addressing Mode: A program can branch to an address determined by the contents of four-bit immediate data, the accumulator, and the B register by executing the TBR instruction.

P Instruction: ROM data addressed in table data addressing mode can be referenced with the P instruction as shown in figure 75. If bit 8 of the ROM data is 1, eight bits of ROM data are written to the accumulator and the B register. If bit 9 is 1, eight bits of ROM data are written to the R1 and R2 port output registers. If both bits 8 and 9 are 1, ROM data is written to the accumulator and the B register, and also to the R1 and R2 port output registers at the same time.

The P instruction has no effect on the program counter

HD40358 Series

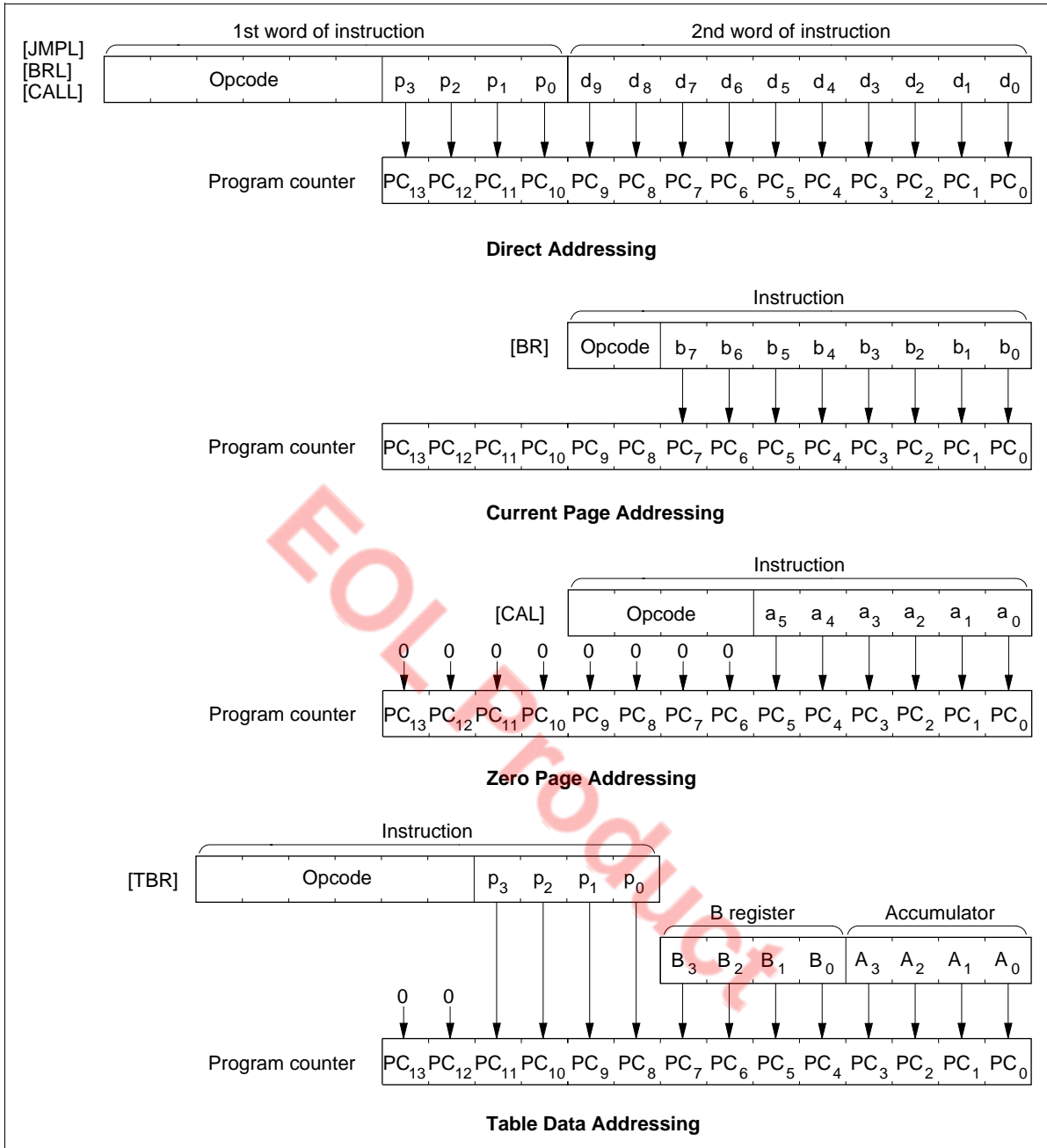

Figure 74 ROM Addressing Modes

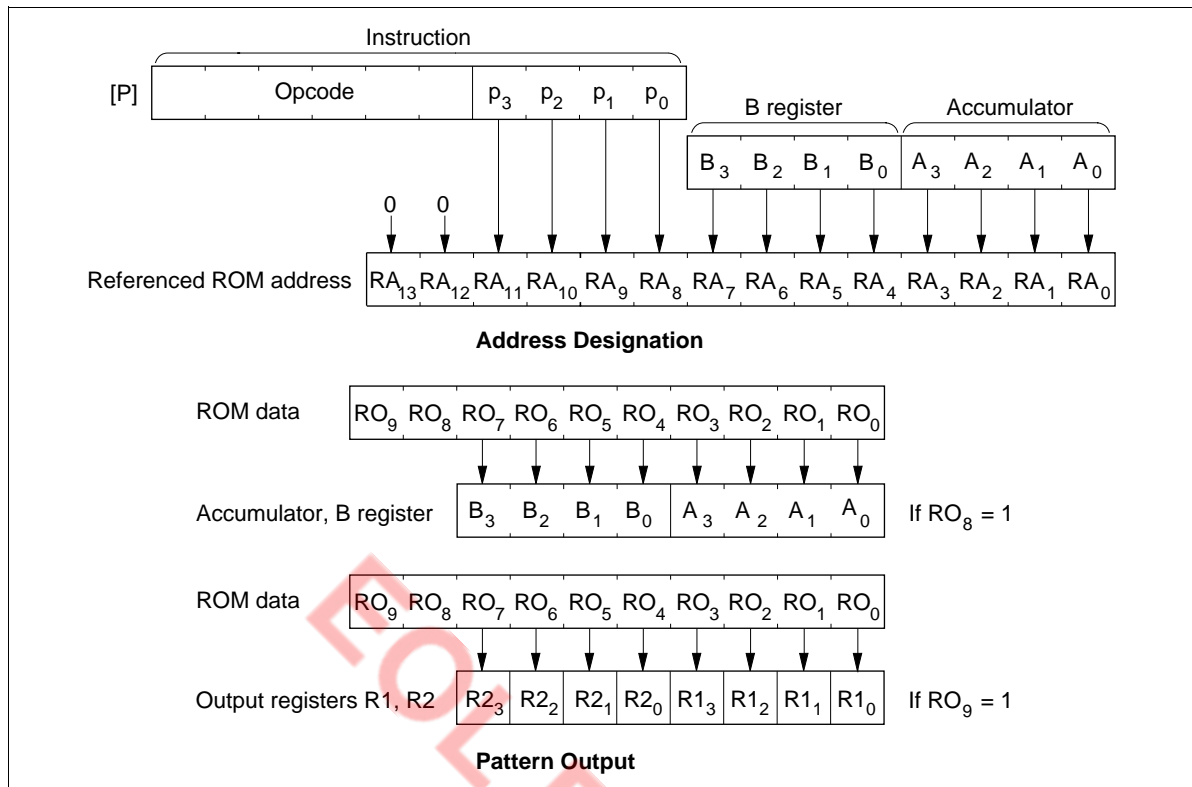

Figure 75 P Instruction

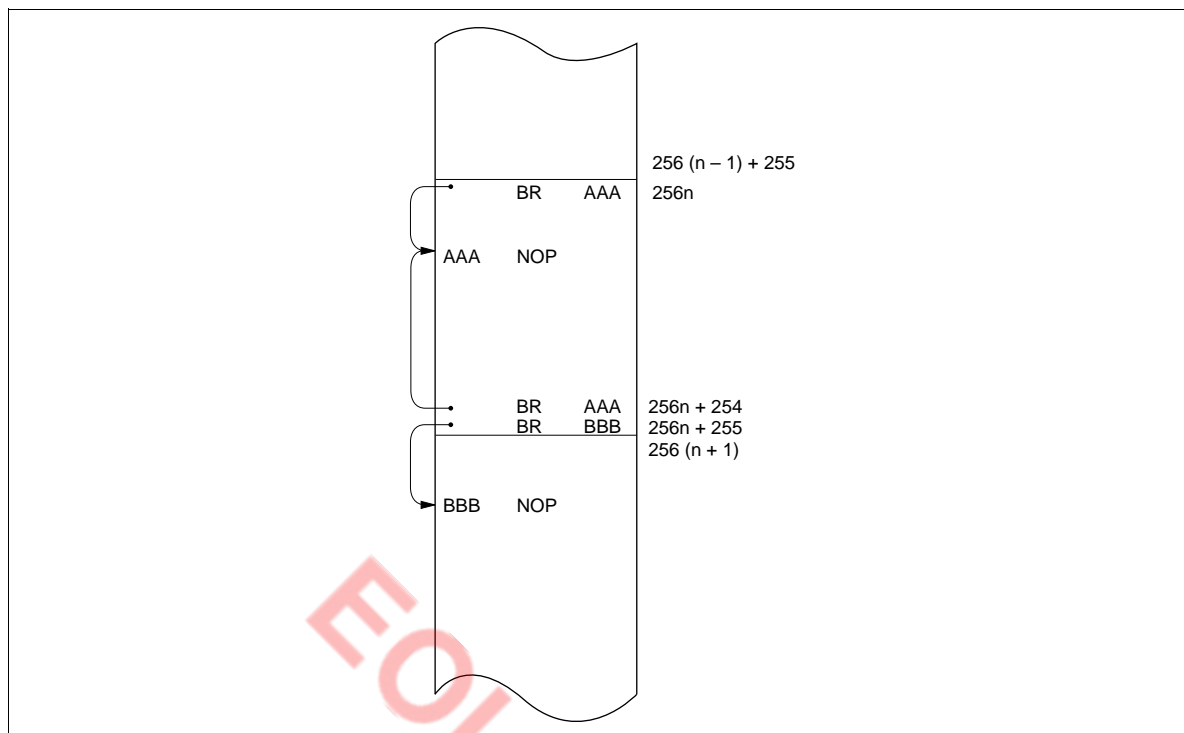

Figure 76 Branching when the Branch Destination is on a Page Boundary

Absolute Maximum Ratings

Item	Symbol	Value	Unit	Notes
Supply voltage	V_{CC}	-0.3 to +7.0	V	
Programming voltage	V_{PP}	-0.3 to +14.0	V	1
Pin voltage	V_T	-0.3 to $V_{CC} + 0.3$	V	2
		-0.3 to +15.0	V	3
Total permissible input current	ΣI_O	105	mA	4
Total permissible output current	$-\Sigma I_O$	50	mA	5
Maximum input current	I_O	4	mA	6, 7
		30	mA	6, 8
Maximum output current	$-I_O$	4	mA	7, 9
Operating temperature	T_{opr}	-20 to +75	°C	
Storage temperature	T_{stg}	-55 to +125	°C	

Notes: Permanent damage may occur if these absolute maximum ratings are exceeded. Normal operation must be under the conditions stated in the electrical characteristics tables. If these conditions are exceeded, the LSI may malfunction or its reliability may be affected.

1. Applies to pin TEST (V_{PP}) of HD407A4359.
2. Applies to all standard voltage pins.
3. Applies to intermediate-voltage pins.
4. The total permissible input current is the total of input currents simultaneously flowing in from all the I/O pins to GND.
5. The total permissible output current is the total of output currents simultaneously flowing out from V_{CC} to all I/O pins.
6. The maximum input current is the maximum current flowing from each I/O pin to GND.
7. Applies to ports D_0 to D_8 , R0, R1, R3, R4, and R8.
8. Applies to port R2.
9. The maximum output current is the maximum current flowing from V_{CC} to each I/O pin.

HD404358 Series

Electrical Characteristics

DC Characteristics (HD407A4359: $V_{CC} = 2.7$ to 5.5 V, $GND = 0$ V, $T_a = -20$ to $+75^\circ\text{C}$; HD404354/HD404356/HD404358/HD40A4354/HD40A4356/HD40A4358: $V_{CC} = 2.7$ to 6.0 V, $GND = 0$ V, $T_a = -20$ to $+75^\circ\text{C}$, unless otherwise specified)

Item	Symbol	Pins	Min	Typ	Max	Unit	Test Condition	Notes
Input high voltage	V_{IH}	$\overline{\text{RESET}}$, $\overline{\text{SCK}}$, $\overline{\text{INT}}_0$, $\overline{\text{INT}}_1$, $\overline{\text{STOPC}}$, EVNB	$0.8V_{CC}$	—	$V_{CC} + 0.3$	V		
		SI	$0.7V_{CC}$	—	$V_{CC} + 0.3$	V		
		OSC_1	$V_{CC} - 0.5$	—	$V_{CC} + 0.3$	V		
Input low voltage	V_{IL}	$\overline{\text{RESET}}$, $\overline{\text{SCK}}$, $\overline{\text{INT}}_0$, $\overline{\text{INT}}_1$, $\overline{\text{STOPC}}$, EVNB	-0.3	—	$0.2V_{CC}$	V		
		SI	-0.3	—	$0.3V_{CC}$	V		
		OSC_1	-0.3	—	0.5	V		
Output high voltage	V_{OH}	$\overline{\text{SCK}}$, SO, TOC	$V_{CC} - 0.5$	—	—	V	$-I_{OH} = 0.5$ mA	
Output low voltage	V_{OL}	$\overline{\text{SCK}}$, SO, TOC	—	—	0.4	V	$I_{OL} = 0.4$ mA	
I/O leakage current	$ I_{IL} $	$\overline{\text{RESET}}$, $\overline{\text{SCK}}$, SI, SO, TOC, OSC_1 , $\overline{\text{INT}}_0$, $\overline{\text{INT}}_1$, $\overline{\text{STOPC}}$, EVNB	—	—	1	μA	$V_{in} = 0$ V to V_{CC}	1
Current dissipation in active mode	I_{CC}	V_{CC}	—	—	5.0	mA	$V_{CC} = 5$ V, $f_{OSC} = 4$ MHz	2
Current dissipation in standby mode	I_{SBY}	V_{CC}	—	—	2.0	mA	$V_{CC} = 5$ V, $f_{OSC} = 4$ MHz	3
Current dissipation in stop mode	I_{STOP}	V_{CC}	—	—	10	μA	$V_{CC} = 5$ V	4
Stop mode retaining voltage	V_{STOP}	V_{CC}	2	—	—	V		

Notes: 1. Excludes current flowing through pull-up MOS and output buffers.

2. I_{CC} is the source current when no I/O current is flowing while the MCU is in reset state.

Test conditions: MCU: Reset
 Pins: $\overline{\text{RESET}}$, TEST at GND

3. I_{SBY} is the source current when no I/O current is flowing while the MCU timer is operating.

Test conditions: MCU: I/O reset
Standby mode
Pins: \overline{RESET} at V_{CC}
TEST at GND
 $D_0-D_8, R0-R4, R8, RA_1$ at V_{CC}

4. This is the source current when no I/O current is flowing.

Test conditions: Pins: \overline{RESET} at V_{CC}
TEST at GND
 $D_0-D_8, R0-R4, R8, RA_1$ at V_{CC}

I/O Characteristics for Standard Pins (HD407A4359: $V_{CC} = 2.7$ to 5.5 V, $GND = 0$ V, $T_a = -20$ to $+75^\circ\text{C}$; HD404354/HD404356/HD404358 /HD40A4354/HD40A4356/HD40A4358: $V_{CC} = 2.7$ to 6.0 V, $GND = 0$ V, $T_a = -20$ to $+75^\circ\text{C}$, unless otherwise specified)

Item	Symbol	Pins	Min	Typ	Max	Unit	Test Condition	Note
Input high voltage	V_{IH}	$D_0-D_8,$ $R0, R1, R3,$ $R4, R8, RA_1$	$0.7V_{CC}$	—	$V_{CC} + 0.3$	V		
Input low voltage	V_{IL}	$D_0-D_8,$ $R0, R1, R3,$ $R4, R8, RA_1$	-0.3	—	$0.3V_{CC}$	V		
Output high voltage	V_{OH}	$D_0-D_8,$ $R0, R1, R3,$ $R4, R8$	$V_{CC} - 0.5$	—	—	V	$-I_{OH} = 0.5$ mA	
Output low voltage	V_{OL}	$D_0-D_8,$ $R0, R1, R3,$ $R4, R8$	—	—	0.4	V	$I_{OL} = 1.6$ mA	
Input leakage current	$ I_{IL} $	$D_0-D_8,$ $R0, R1, R3,$ $R4, R8, RA_1$	—	—	1	μA	$V_{in} = 0$ V to V_{CC}	1
Pull-up MOS current	$-I_{PU}$	$D_0-D_8,$ $R0, R1, R3,$ $R4, R8$	30	150	300	μA	$V_{CC} = 5$ V, $V_{in} = 0$ V	

Note: 1. Output buffer current is excluded.

HD404358 Series

I/O Characteristics for Intermediate-Voltage Pins (HD407A4359: $V_{CC} = 2.7$ to 5.5 V, $GND = 0$ V, $T_a = -20$ to $+75^\circ\text{C}$; HD404354/HD404356/HD404358 /HD40A4354/HD40A4356/HD 40A4358: $V_{CC} = 2.7$ to 6.0 V, $GND = 0$ V, $T_a = -20$ to $+75^\circ\text{C}$, unless otherwise specified)

Item	Symbol	Pins	Min	Typ	Max	Unit	Test Condition	Note
Input high voltage	V_{IH}	R2	$0.7V_{CC}$	—	12	V		
Input low voltage	V_{IL}	R2	-0.3	—	$0.3V_{CC}$	V		
Output high voltage	V_{OH}	R2	11.5	—	—	V	500 k Ω at 12 V	
Output low voltage	V_{OL}	R2	—	—	0.4	V	$I_{OL} = 0.4$ mA	
			—	—	2.0	V	$I_{OL} = 15$ mA, $V_{CC} = 4.5$ to 5.5 V	
I/O leakage current	$ I_{IL} $	R2	—	—	20	μA	$V_{in} = 0$ V to 12 V	1

Note: 1. Excludes output buffer current.

HD404358 Series

A/D Converter Characteristics (HD407A4359: $V_{CC} = 2.7$ to 5.5 V, $GND = 0$ V, $T_a = -20$ to $+75^\circ\text{C}$; HD404354/HD404356/HD404358 /HD40A4354/HD40A4356/HD40A4358: $V_{CC} = 2.7$ to 6.0 V, $GND = 0$ V, $T_a = -20$ to $+75^\circ\text{C}$, unless otherwise specified)

Item	Symbol	Pins	Min	Typ	Max	Unit	Test Condition	Note
Analog supply voltage	AV_{CC}	AV_{CC}	$V_{CC} - 0.3$	V_{CC}	$V_{CC} + 0.3$	V		1
Analog input voltage	AV_{in}	AN_0-AN_7	AV_{SS}	—	AV_{CC}	V		
Current flowing between AV_{CC} and AV_{SS}	I_{AD}		—	—	200	μA	$V_{CC} = AV_{CC} = 5.0$ V	
Analog input capacitance	CA_{in}	AN_0-AN_7	—	—	30	pF		
Resolution			8	8	8	Bit		
Number of input channels			0	—	8	Channel		
Absolute accuracy			—	—	± 2.0	LSB		
Conversion time			34	—	67	t_{cyc}		
Input impedance		AN_0-AN_7	1	—	—	$M\Omega$		

Note: 1. Connect this to V_{CC} if the A/D converter is not used.

HD404358 Series

Standard $f_{OSC} = 5.0$ MHz Version AC Characteristics (HD404354/HD404356/HD404358: $V_{CC} = 2.7$ to 6.0 V, $GND = 0$ V, $T_a = -20$ to $+75^\circ\text{C}$)

Item	Symbol	Pins	Min	Typ	Max	Unit	Test Condition	Note
Clock oscillation frequency	f_{OSC}	OSC ₁ , OSC ₂	0.4	4	5.0	MHz	1/4 system clock division ratio	
Instruction cycle time	t_{cyc}		0.8	1	10	μs		
Oscillation stabilization time (ceramic oscillator)	t_{RC}	OSC ₁ , OSC ₂	—	—	7.5	ms		1
Oscillation stabilization time (crystal oscillator)	t_{RC}	OSC ₁ , OSC ₂	—	—	40	ms		1
External clock high width	t_{CPH}	OSC ₁	80	—	—	ns		2
External clock low width	t_{CPL}	OSC ₁	80	—	—	ns		2
External clock rise time	t_{CPr}	OSC ₁	—	—	20	ns		2
External clock fall time	t_{CpF}	OSC ₁	—	—	20	ns		2
$\overline{\text{INT}}_0$, $\overline{\text{INT}}_1$, EVNB high widths	t_{IH}	$\overline{\text{INT}}_0$, $\overline{\text{INT}}_1$, EVNB	2	—	—	t_{cyc}		3
$\overline{\text{INT}}_0$, $\overline{\text{INT}}_1$, EVNB low widths	t_{IL}	$\overline{\text{INT}}_0$, $\overline{\text{INT}}_1$, EVNB	2	—	—	t_{cyc}		3
RESET low width	t_{RSTL}	RESET	2	—	—	t_{cyc}		4
STOPC low width	t_{STPL}	STOPC	1	—	—	t_{RC}		5
RESET rise time	t_{RSTr}	RESET	—	—	20	ms		4
STOPC rise time	t_{STPr}	STOPC	—	—	20	ms		5
Input capacitance	C_{in}	All input pins except and R2	—	—	15	pF	$f = 1$ MHz, $V_{in} = 0$ V	
		R2	—	—	30	pF	$f = 1$ MHz, $V_{in} = 0$ V	

Notes: 1. The oscillation stabilization time is the period required for the oscillator to stabilize in the following situations:

- After V_{CC} reaches 2.7 V at power-on.
- After $\overline{\text{RESET}}$ input goes low when stop mode is cancelled.
- After $\overline{\text{STOPC}}$ input goes low when stop mode is cancelled.

To ensure the oscillation stabilization time at power-on or when stop mode is cancelled, $\overline{\text{RESET}}$ or $\overline{\text{STOPC}}$ must be input for at least a duration of t_{RC} .

When using a crystal or ceramic oscillator, consult with the manufacturer to determine what stabilization time is required, since it will depend on the circuit constants and stray capacitance.

- Refer to figure 77.
- Refer to figure 78.
- Refer to figure 79.
- Refer to figure 80.

HD404358 Series

High-Speed $f_{OSC} = 8.5$ MHz Version AC Characteristics (HD407A4359: $V_{CC} = 2.7$ to 5.5 V, $GND = 0$ V, $T_a = -20$ to $+75^\circ\text{C}$; HD40A4354/HD40A4356/HD40A4358: $V_{CC} = 2.7$ to 6.0 V, $GND = 0$ V, $T_a = -20$ to $+75^\circ\text{C}$)

Item	Symbol	Pins	Min	Typ	Max	Unit	Test Condition	Note
Clock oscillation frequency	f_{OSC}	OSC ₁ , OSC ₂	0.4	4	5.0	MHz	1/4 system clock division ratio	
			0.4	4	8.5	MHz	1/4 system clock division ratio, $V_{CC} = 4.5$ to 5.5 V	
Instruction cycle time	t_{cyc}		0.8	1	10	μs		
			0.47	1	10	μs	$V_{CC} = 4.5$ to 5.5 V	
Oscillation stabilization time (ceramic oscillator)	t_{RC}	OSC ₁ , OSC ₂	—	—	7.5	ms		1
Oscillation stabilization time (crystal oscillator)	t_{RC}	OSC ₁ , OSC ₂	—	—	40	ms		1
External clock high width	t_{CPH}	OSC ₁	80	—	—	ns		2
			47	—	—	ns	$V_{CC} = 4.5$ to 5.5 V	2
External clock low width	t_{CPL}	OSC ₁	80	—	—	ns		2
			47	—	—	ns	$V_{CC} = 4.5$ to 5.5 V	2
External clock rise time	t_{CPr}	OSC ₁	—	—	20	ns		2
			—	—	15	ns	$V_{CC} = 4.5$ to 5.5 V	2
External clock fall time	t_{CPf}	OSC ₁	—	—	20	ns		2
			—	—	15	ns	$V_{CC} = 4.5$ to 5.5 V	2
$\overline{\text{INT}}_0$, $\overline{\text{INT}}_1$, EVNB high widths	t_{IH}	$\overline{\text{INT}}_0$, $\overline{\text{INT}}_1$, EVNB	2	—	—	t_{cyc}		3
$\overline{\text{INT}}_0$, $\overline{\text{INT}}_1$, EVNB low widths	t_{IL}	$\overline{\text{INT}}_0$, $\overline{\text{INT}}_1$, EVNB	2	—	—	t_{cyc}		3
RESET low width	t_{RSTL}	RESET	2	—	—	t_{cyc}		4
STOPC low width	t_{STPL}	STOPC	1	—	—	t_{RC}		5
RESET rise time	t_{RSTr}	RESET	—	—	20	ms		4
STOPC rise time	t_{STPr}	STOPC	—	—	20	ms		5
Input capacitance	C_{in}	All input pins except TEST and R2	—	—	15	pF	$f = 1$ MHz, $V_{in} = 0$ V	
		TEST	—	—	15	pF	$f = 1$ MHz, $V_{in} = 0$ V	6
			—	—	180	pF	$f = 1$ MHz, $V_{in} = 0$ V	7
		R2	—	—	30	pF	$f = 1$ MHz, $V_{in} = 0$ V	

HD404358 Series

Notes: 1. The oscillation stabilization time is the period required for the oscillator to stabilize in the following situations:

- a. After V_{CC} reaches 2.7 V at power-on.
- b. After \overline{RESET} input goes low when stop mode is cancelled.
- c. After \overline{STOPC} input goes low when stop mode is cancelled.

To ensure the oscillation stabilization time at power-on or when stop mode is cancelled, \overline{RESET} or \overline{STOPC} must be input for at least a duration of t_{RC} .

When using a crystal or ceramic oscillator, consult with the manufacturer to determine what stabilization time is required, since it will depend on the circuit constants and stray capacitance.

2. Refer to figure 77.
3. Refer to figure 78.
4. Refer to figure 79.
5. Refer to figure 80.
6. Applies to the HD40A4354, HD40A4356, HD40A4358.
7. Applies to the HD407A4359.

EOL Product

HD404358 Series

Serial Interface Timing Characteristics (HD407A4359: $V_{CC} = 2.7$ to 5.5 V, $GND = 0$ V, $T_a = -20$ to $+75^\circ\text{C}$; HD404354/HD404356/HD404358/HD40A4354/HD40A4356/HD40A4358: $V_{CC} = 2.7$ to 6.0 V, $GND = 0$ V, $T_a = -20$ to $+75^\circ\text{C}$, unless otherwise specified)

During Transmit Clock Output

Item	Symbol	Pins	Min	Typ	Max	Unit	Test Condition	Note
Transmit clock cycle time	t_{Syc}	\overline{SCK}	1	—	—	t_{cyc}	Load shown in figure 82	1
Transmit clock high width	t_{SCKH}	\overline{SCK}	0.4	—	—	t_{Syc}	Load shown in figure 82	1
Transmit clock low width	t_{SCKL}	\overline{SCK}	0.4	—	—	t_{Syc}	Load shown in figure 82	1
Transmit clock rise time	t_{SCKr}	\overline{SCK}	—	—	80	ns	Load shown in figure 82	1
Transmit clock fall time	t_{SCKf}	\overline{SCK}	—	—	80	ns	Load shown in figure 82	1
Serial output data delay time	t_{DSO}	SO	—	—	300	ns	Load shown in figure 82	1
Serial input data setup time	t_{SSI}	SI	100	—	—	ns		1
Serial input data hold time	t_{HSI}	SI	200	—	—	ns		1

During Transmit Clock Input

Item	Symbol	Pins	Min	Typ	Max	Unit	Test Condition	Note
Transmit clock cycle time	t_{Syc}	\overline{SCK}	1	—	—	t_{cyc}		1
Transmit clock high width	t_{SCKH}	\overline{SCK}	0.4	—	—	t_{Syc}		1
Transmit clock low width	t_{SCKL}	\overline{SCK}	0.4	—	—	t_{Syc}		1
Transmit clock rise time	t_{SCKr}	\overline{SCK}	—	—	80	ns		1
Transmit clock fall time	t_{SCKf}	\overline{SCK}	—	—	80	ns		1
Serial output data delay time	t_{DSO}	SO	—	—	300	ns	Load shown in figure 82	1
Serial input data setup time	t_{SSI}	SI	100	—	—	ns		1
Serial input data hold time	t_{HSI}	SI	200	—	—	ns		1

Note: 1. Refer to figure 81.

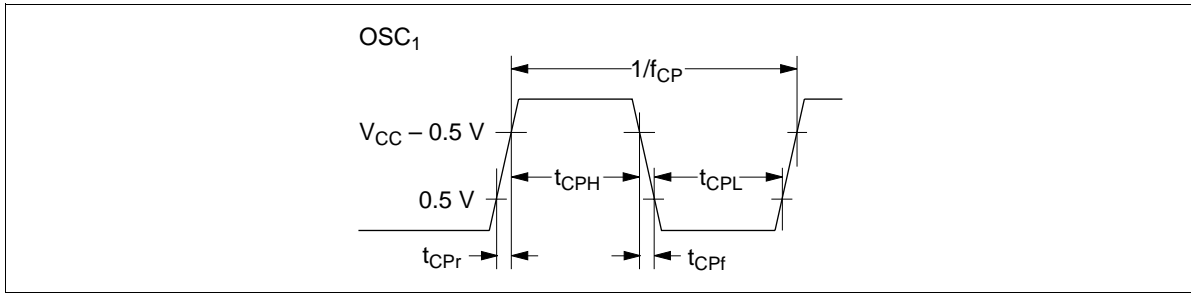

Figure 77 External Clock Timing

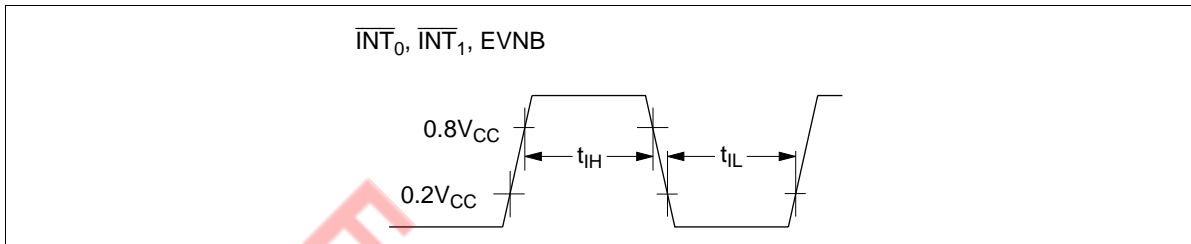

Figure 78 Interrupt Timing

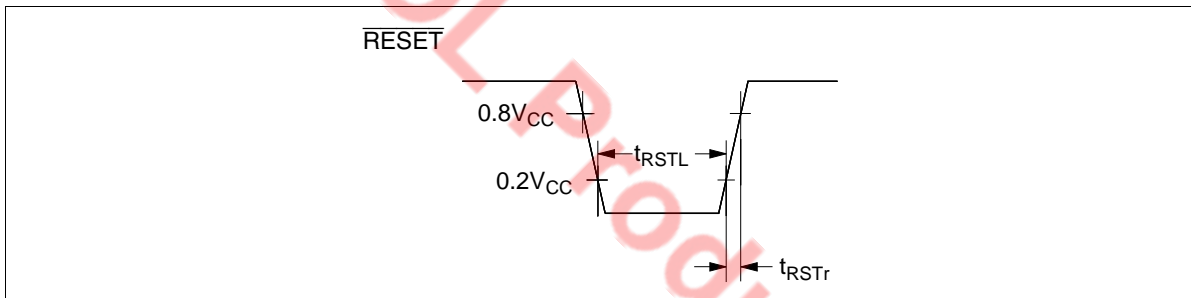

Figure 79 RESET Timing

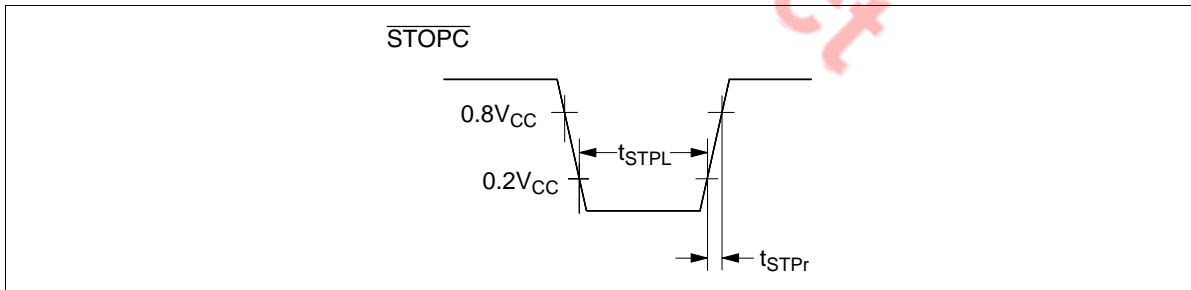

Figure 80 STOPC Timing

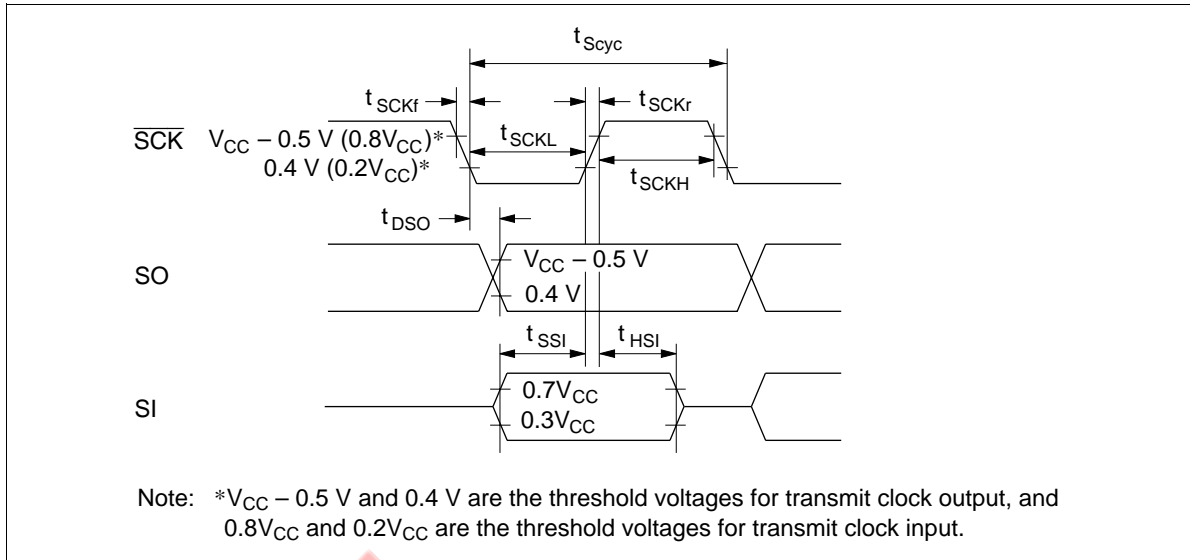

Figure 81 Serial Interface Timing

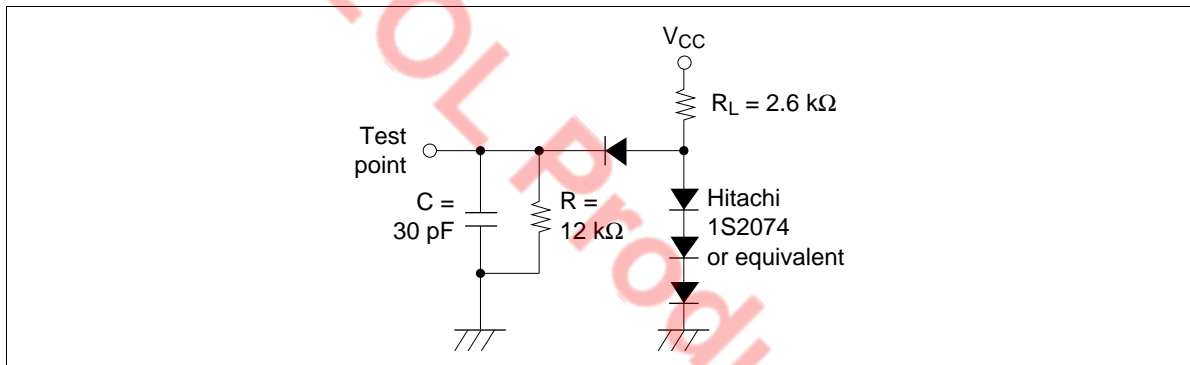

Figure 82 Timing Load Circuit

HD404358 Series

Notes on ROM Out

Please pay attention to the following items regarding ROM out.

On ROM out, fill the ROM area indicated below with 1s to create the same data size for the HD404354, HD40A4354, HD404356 and HD40A4356 as an 8-kword version (HD404358, HD40A4358). The 8-kword and 16-kword data sizes are required to change ROM data to mask manu facturing data since the program used is for an 8-k or 16-kword version.

This limitation applies when using an EPROM or a data base.

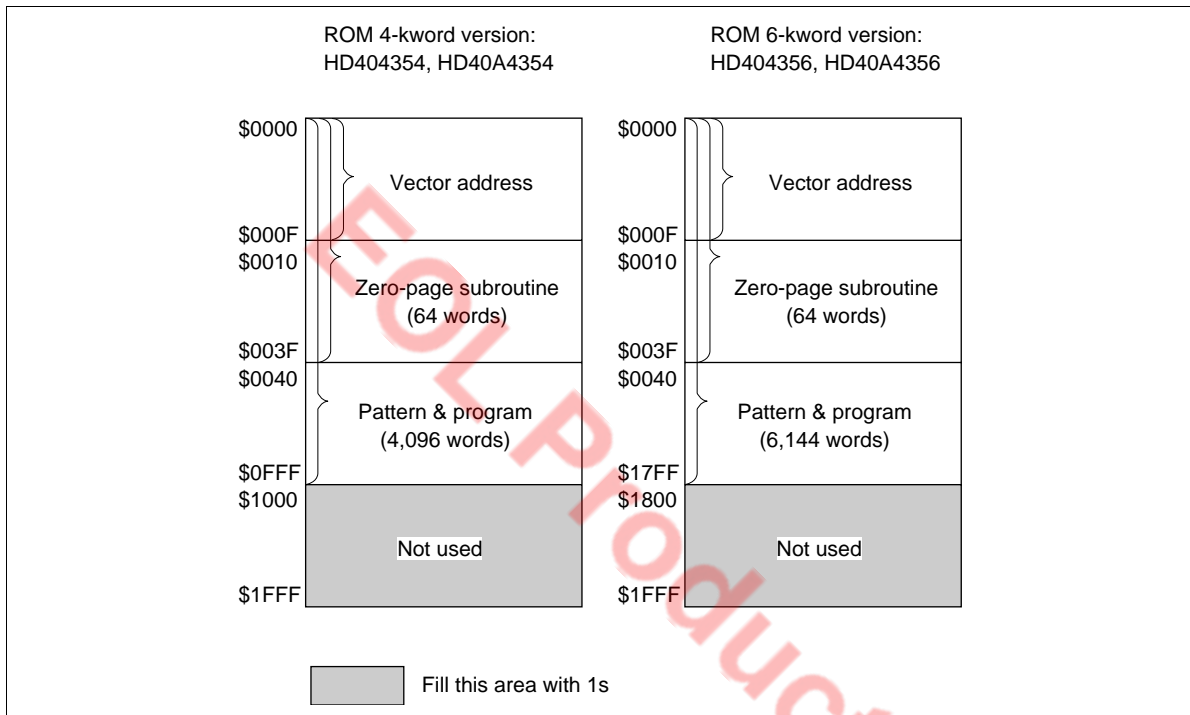

HD404354/HD404356/HD404358/HD40A4354/HD40A4356/HD40A4358

Please check off the appropriate applications and enter the necessary information.

1. ROM size

<input type="checkbox"/> 5 MHz operation	HD404354	4-kword	Date of order	
<input type="checkbox"/> 8.5 MHz operation	HD40A4354		Customer	
<input type="checkbox"/> 5 MHz operation	HD404356	6-kword	Department	
<input type="checkbox"/> 8.5 MHz operation	HD40A4356		Name	
<input type="checkbox"/> 5 MHz operation	HD404358	8-kword	ROM code name	
<input type="checkbox"/> 8.5 MHz operation	HD40A4358		LSI number	

2. ROM code media

Please specify the first type below (the upper bits and lower bits are mixed together), when using the EPROM on-package microcomputer type (including ZTAT™ version).

<input type="checkbox"/>	EPROM: The upper bits and lower bits are mixed together. The upper five bits and lower five bits are programmed to the same EPROM in alternating order (i.e., LULULU...).
<input type="checkbox"/>	EPROM: The upper bits and lower bits are separated. The upper five bits and lower five bits are programmed to different EPROMS.

3. System Oscillator (OSC1, OSC2)

<input type="checkbox"/> Ceramic oscillator	f =	MHz
<input type="checkbox"/> Crystal oscillator	f =	MHz
<input type="checkbox"/> External clock	f =	MHz

4. Stop mode

<input type="checkbox"/> Used
<input type="checkbox"/> Not used

5. Package

<input type="checkbox"/> DP-42S
<input type="checkbox"/> FP-44A

HD404358 Series

Cautions

1. Hitachi neither warrants nor grants licenses of any rights of Hitachi's or any third party's patent, copyright, trademark, or other intellectual property rights for information contained in this document. Hitachi bears no responsibility for problems that may arise with third party's rights, including intellectual property rights, in connection with use of the information contained in this document.
2. Products and product specifications may be subject to change without notice. Confirm that you have received the latest product standards or specifications before final design, purchase or use.
3. Hitachi makes every attempt to ensure that its products are of high quality and reliability. However, contact Hitachi's sales office before using the product in an application that demands especially high quality and reliability or where its failure or malfunction may directly threaten human life or cause risk of bodily injury, such as aerospace, aeronautics, nuclear power, combustion control, transportation, traffic, safety equipment or medical equipment for life support.
4. Design your application so that the product is used within the ranges guaranteed by Hitachi particularly for maximum rating, operating supply voltage range, heat radiation characteristics, installation conditions and other characteristics. Hitachi bears no responsibility for failure or damage when used beyond the guaranteed ranges. Even within the guaranteed ranges, consider normally foreseeable failure rates or failure modes in semiconductor devices and employ systemic measures such as fail-safes, so that the equipment incorporating Hitachi product does not cause bodily injury, fire or other consequential damage due to operation of the Hitachi product.
5. This product is not designed to be radiation resistant.
6. No one is permitted to reproduce or duplicate, in any form, the whole or part of this document without written approval from Hitachi.
7. Contact Hitachi's sales office for any questions regarding this document or Hitachi semiconductor products.