

# 16-bit Proprietary Microcontroller

CMOS

## F<sup>2</sup>MC-16LX MB90330 Series

### MB90333A/F334A/V330A

#### ■ DESCRIPTION

The MB90330 series are 16-bit microcontrollers designed for applications, such as personal computer peripheral devices, that require USB communications. The USB feature supports not only 12-Mbps Function operation but also Mini-HOST operation. It is equipped with functions that are suitable for personal computer peripheral devices such as displays and audio devices, and control of mobile devices that support USB communications. While inheriting the AT architecture of the F<sup>2</sup>MC\* family, the instruction set supports the C language and extended addressing modes and contains enhanced signed multiplication and division instructions as well as a substantial collection of improved bit manipulation instructions. In addition, long word processing is now available by introducing a 32-bit accumulator.

\* : F<sup>2</sup>MC stands for FUJITSU Flexible Microcontroller, a registered trademark of FUJITSU LIMITED.

#### ■ FEATURES

##### • Clock

- Built-in oscillation circuit and PLL clock frequency multiplication circuit
- Oscillation clock
- The main clock is the oscillation clock divided into 2 (for oscillation 6 MHz : 3 MHz)
- Clock for USB is 48 MHz
- Machine clock frequency of 6 MHz, 12 MHz, or 24 MHz selectable
- Minimum execution time of instruction : 41.6 ns (6 MHz oscillation clock, 4-time multiplied : machine clock 24 MHz and at operating  $V_{CC} = 3.3$  V.

(Continued)

#### ■ PACKAGES

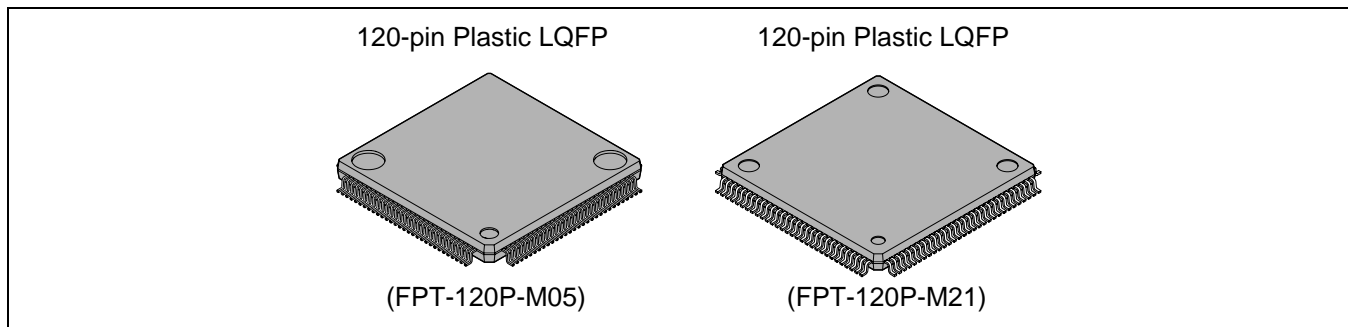

# MB90330 Series

(Continued)

- **The maximum memory space : 16 MB**
- **24-bit addressing**
- **Bank addressing**
- **Instruction system**
  - Data types : Bit, Byte, Word and Long word
  - Addressing mode (23 types)
  - Enhanced high-precision computing with 32-bit accumulator
  - Enhanced Multiply/Divide instructions with sign and the RETI instruction
- **Instruction system compatible with high-level language (C language) and multi-task**
  - Employing system stack pointer
  - Instruction set symmetry and barrel shift instructions
- **Program Patch Function (2 address pointer)**
- **4-byte instruction queue**
- **Interrupt function**
  - Priority levels are programmable
  - 32 interrupts function
- **Data transfer function**
  - Extended intelligent I/O service function (EI<sup>2</sup>OS) : Maximum of 16 channels
  - $\mu$ DMAC : Maximum 16 channels
- **Low Power Consumption Mode**
  - Sleep mode (with the CPU operating clock stopped)
  - Time-base timer mode (with the oscillator clock and time-base timer operating)
  - Stop mode (with the oscillator clock stopped)
  - CPU intermittent operation mode (with the CPU operating at fixed intervals of set cycles)
  - Watch mode (with 32 kHz oscillator clock and watch timer operating)
- **Package**
  - LQFP-120P (FPT-120P-M05 : 0.40 mm pin pitch)
  - LQFP-120P (FPT-120P-M21 : 0.50 mm pin pitch)
- **Process : CMOS technology**
- **Operation guaranteed temperature : - 40 °C to + 85 °C (0 °C to + 70 °C when USB is in use)**

## ■ INTERNAL PERIPHERAL FUNCTION (RESOURCE)

- **I/O port : Max 94 ports**
- **Time-base timer : 1 channel**
- **Watchdog timer : 1 channel**
- **Watch timer : 1 channel**
- **16-bit reload timer : 3 channels**
- **Multi-functional timer**
  - 16-bit free run timer : 1 channel
  - Output compare : 4 channels  
An interrupt request can be output when the 16-bit free-run timer value matches the compare register value.
  - Input capture : 4 channels  
Upon detection of the effective edge of the signal input to the external input pin, the input capture unit sets the input capture data register to the 16-bit free-run timer value to output an interrupt request.
  - 8/16-bit PPG timer (8-bit × 6 channels or 16-bit × 3 channels) the period and duty of the output pulse can be set by the program.
  - 16-bit PWC timer : 1 channel  
Timer function and pulse width measurement function
- **UART : 4 channels**
  - Full-duplex double buffer (8-bit length)
  - Asynchronous transfer or clock-synchronous serial (I/O extended serial) transfer can be set.
- **I/O extended serial interface : 1 channel**
- **DTP/External interrupt circuit (8 channels)**
  - Activate the extended intelligent I/O service by external interrupt input
  - Interrupt output by external interrupt input
- **Delay interrupt output module**
  - Output an interrupt request for task switching
- **8/10-bit A/D converter : 16 channels**
  - 8-bit resolution or 10-bit resolution can be set.
- **USB : 1 channel**
  - USB function (conform to USB2.0 Full Speed)
  - Full Speed is supported/Endpoint are specifiable up to six.
  - Dual port RAM (The FIFO mode is supported).
  - Transfer type : Control, Interrupt, Bulk, or Isochronous transfer possible
  - USB Mini-HOST function
- **I<sup>2</sup>C\* Interface : 3 channels**
  - Supports Intel SM bus standard and Phillips I<sup>2</sup>C bus standards
  - Two-wire data transfer protocol specification
  - Master and slave transmission/reception

\* : I<sup>2</sup>C license :

Purchase of Fujitsu I<sup>2</sup>C components conveys a license under the Philips I<sup>2</sup>C Patent Rights to use, these components in an I<sup>2</sup>C system provided that the system conforms to the I<sup>2</sup>C Standard Specification as defined by Philips.

# MB90330 Series

## ■ PRODUCT LINEUP

Part number	MB90V330A	MB90F334A	MB90333A
Type	For evaluation	Built-in Flash memory	Built-in Mask ROM
ROM capacity	No	384 KB	256 KB
RAM capacity	28 KB	24 KB	16 KB
Emulator-specific power supply *	Used bit	—	
CPU functions	Number of basic instructions : 351 instructions Minimum instruction execution time : 41.6 ns/at oscillation of 6 MHz (When 4 times are used : Machine clock of 24 MHz) Addressing type : 23 types Program Patch Function : For 2 address pointers Maximum memory space : 16 MB		
Ports	I/O Ports (CMOS) 94 ports		
UART	Equipped with full-duplex double buffer Clock synchronous or asynchronous operation selectable It can also be used for I/O serial Built-in special baud-rate generator Built-in 4 channels		
16-bit reload timer	16-bit reload timer operation Built-in 3 channels		
Multi-functional timer	16-bit free run timer × 1 channel Output compare × 4 channels Input capture × 4 channels 8/16-bit PPG timer (8-bit mode × 6 channels, 16-bit mode × 3 channels) 16-bit PWC timer × 1 channel		
8/10-bit A/D converter	16 channels (input multiplex) 8-bit resolution or 10-bit resolution can be set. Conversion time : 7.16 μs at minimum (24 MHz machine clock at maximum)		
DTP/External interrupt	8 channels Interrupt factor : “L”→“H” edge/“H”→“L” edge/“L” level/“H” level selectable		
I <sup>2</sup> C	3 channels		
I/O extended serial interface	1 channel		
USB	1 channel USB function (conform to USB2.0 Full Speed) USB Mini-HOST function		
External bus interface	For multi-bus/non-multi-bus		
Withstand voltage of 5 V	16 ports (excluding VBUS and I/O for I <sup>2</sup> C)		
Low Power Consumption Mode	Sleep mode/Time-base timer mode/Stop mode/CPU intermittent mode/Watch mode		
Process	CMOS		
Operating voltage	3.3 V ± 0.3 V (at maximum machine clock 24 MHz)		

\* : It is setting of Jumper switch (TOOL VCC) when Emulator (MB2147-01) is used. Please refer to the MB2147-01 or MB2147-20 hardware manual (3.3 Emulator-dedicated Power Supply Switching) about details.

## ■ PACKAGES AND PRODUCT MODELS

Package	MB90333A	MB90F334A	MB90V330A
FPT-120P-M05 (LQFP-0.40 mm)	○	○	×
FPT-120P-M21 (LQFP-0.50 mm)	○	○	×
PGA-299C-A01 (PGA)	×	×	○

○ : Yes × : No

Note : For detailed information on each package, see "■ PACKAGE DIMENSIONS".

# MB90330 Series

## PIN ASSIGNMENT

(TOP VIEW)

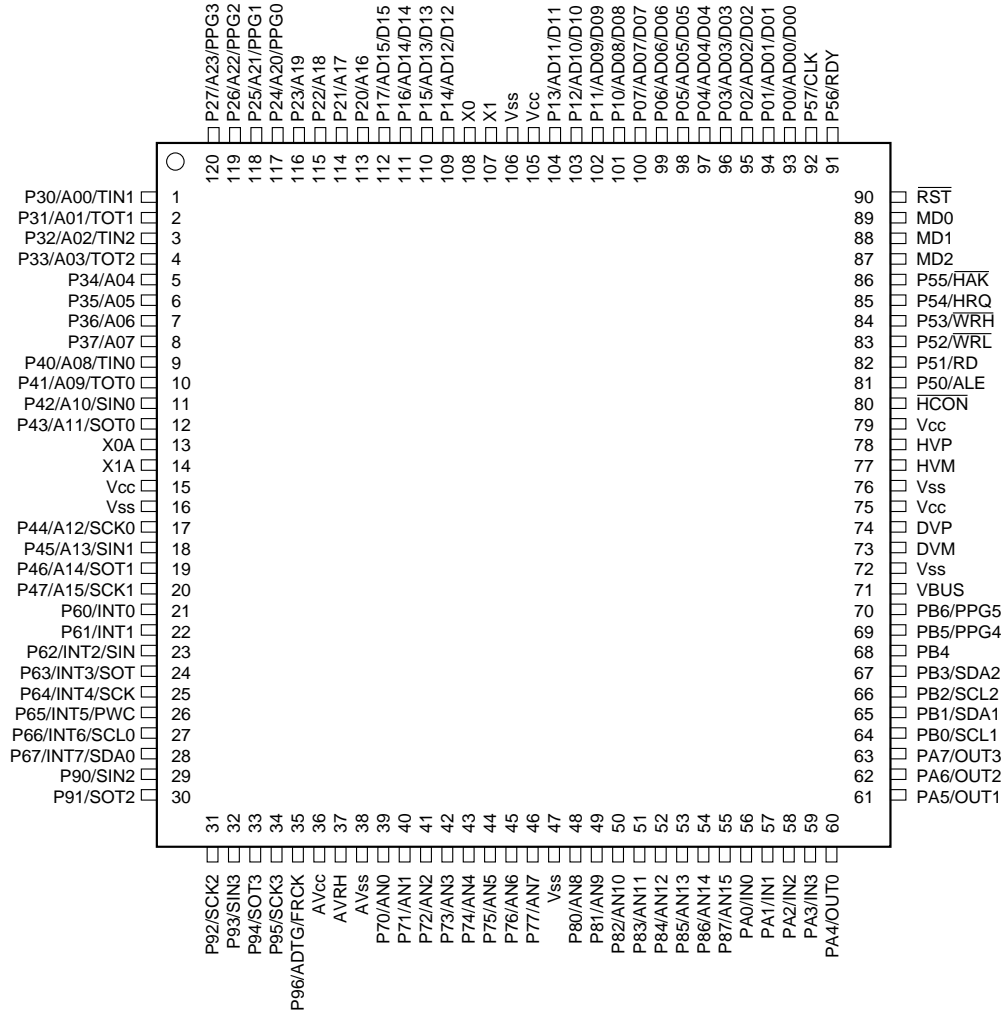

(FPT-120P-M05 / FPT-120P-M21)

## ■ PIN DESCRIPTION

Pin no. LQFP	Pin name	Circuit type*	Function
108, 107	X0, X1	A	Terminals to connect the oscillator. When connecting an external clock, leave the X1 pin side unconnected.
13, 14	X0A, X1A	A	32 kHz oscillation terminals.
90	$\overline{RST}$	F	External reset input pin.
93 to 100	P00 to P07	H	General purpose input/output port. The ports can be set to be added with a pull-up resistor (RD00 to RD07 = 1) by the pull-up resistor setting register (RDR0). (When the power output is set, it is invalid.)
	AD00 to AD07		Function as an I/O pin for the low-order external address and data bus in multiplex mode.
	D00 to D07		Function as an output pin for the low-order external data bus in non-multiplex mode.
101 to 104	P10 to P13	H	General purpose input/output port. The ports can be set to be added with a pull-up resistor (RD10 to RD13 = 1) by the pull-up resistor setting register (RDR1). (When the power output is set, it is invalid.)
	AD08 to AD11		Function as an I/O pin for the high-order external address and data bus in multiplex mode.
	D08 to D11		Function as an output pin for the high-order external data bus in non-multiplex mode.
109 to 112	P14 to P17	H	General purpose input/output port. The ports can be set to be added with a pull-up resistor (RD14 to RD17 = 1) by the pull-up resistor setting register (RDR1). (When the power output is set, it is invalid.)
	AD12 to D15		Function as an I/O pin for the high-order external address and data bus in multiplex mode.
	D12 to D15		Function as an output pin for the high-order external data bus in non-multiplex mode.
113 to 116	P20 to P23	D	This is a general purpose I/O port. When the bits of external address output control register (HACR) are set to "1" in external bus mode, these pins function as general purpose I/O ports.
	A16 to A19		When the bits of external address output control register (HACR) are set to "0" in multiplex mode, these pins function as address high output pins (A16 to A19).
	A16 to A19		When the bits of external address output control register (HACR) are set to "0" in non-multiplex mode, these pins function as address high output pins (A16 to A19).

(Continued)

# MB90330 Series

Pin no. LQFP	Pin name	Circuit type*	Function
117 to 120	P24 to P27	D	This is a general purpose I/O port. When the bits of external address output control register (HACR) are set to "1" in external bus mode, these pins function as general purpose I/O ports.
	A20 to A23		When the bits of external address output control register (HACR) are set to "0" in multiplex mode, these pins function as address high output pins (A20 to A23).
	A20 to A23		When the bits of external address output control register (HACR) are set to "0" in non-multiplex mode, these pins function as address high output pins (A20 to A23).
	PPG0 to PPG3		Function as ch0 to ch3 output pins for the 8-bit PPG timer.
1	P30	D	General purpose input/output port.
	A00		Function as the external address pin in non-multi-bus mode.
	TIN1		Function as an event input pin for 16-bit reload timer ch1.
2	P31	D	General purpose input/output port.
	A01		Function as the external address pin in non-multi-bus mode.
	TOT1		Function as the output pin for 16-bit reload timer ch1.
3	P32	D	General purpose input/output port.
	A02		Function as the external address pin in non-multi-bus mode.
	TIN2		Function as an event input pin for 16-bit reload timer ch2.
4	P33	D	General purpose input/output port.
	A03		Function as the external address pin in non-multi-bus mode.
	TOT2		Function as the output pin for 16-bit reload timer ch2.
5 to 8	P34 to P37	D	General purpose input/output port.
	A04 to A07		Function as the external address pin in non-multi-bus mode.
9	P40	G	General purpose input/output port.
	A08		Function as the external address pin in non-multi-bus mode.
	TIN0		Function as an event input pin for 16-bit reload timer ch0.
10	P41	G	General purpose input/output port.
	A09		Function as the external address pin in non-multi-bus mode.
	TOT0		Function as the output pin for 16-bit reload timer ch0.
11	P42	G	General purpose input/output port.
	A10		Function as the external address pin in non-multi-bus mode.
	SIN0		Function as a data input pin for UART ch0.
12	P43	G	General purpose input/output port.
	A11		Function as the external address pin in non-multi-bus mode.
	SOT0		Function as a data output pin for UART ch0.
17	P44	G	General purpose input/output port.
	A12		Function as the external address pin in non-multi-bus mode.
	SCK0		Function as a clock I/O pin for UART ch0.

(Continued)



# MB90330 Series

Pin no. LQFP	Pin name	Circuit type*	Function
18	P45	G	General purpose input/output port.
	A13		Function as the external address pin in non-multi-bus mode.
	SIN1		Function as a data input pin for UART ch1.
19	P46	G	General purpose input/output port.
	A14		Function as the external address pin in non-multi-bus mode.
	SOT1		Function as a data output pin for UART ch1.
20	P47	G	General purpose input/output port.
	A15		Function as the external address pin in non-multi-bus mode.
	SCK1		Function as a clock I/O pin for UART ch1.
81	P50	L	General purpose input/output port.
	ALE		Function as the address latch enable signal (ALE) pin in external bus mode.
82	P51	L	General purpose input/output port.
	$\overline{RD}$		Function as the read strobe output ( $\overline{RD}$ ) pin in external bus mode.
83	P52	L	General purpose input/output port.
	$\overline{WRL}$		Function as the data write strobe output ( $\overline{WRL}$ ) pin on the lower side in external bus mode. This pin functions as a general-purpose I/O port when the WRE bit in the EPCR register is "0".
84	P53	L	General purpose input/output port.
	$\overline{WRH}$		Function as the data write strobe output ( $\overline{WRH}$ ) pin on the higher side in bus width 16-bit external bus mode. This pin functions as a general-purpose I/O port when the WRE bit in the EPCR register is "0".
85	P54	L	General purpose input/output port.
	HRQ		Function as the hold request input (HRQ) pin in external bus mode. This pin functions as a general-purpose I/O port when the HDE bit in the EPCR register is "0".
86	P55	L	General purpose input/output port.
	$\overline{HAK}$		Function as the hold acknowledge output ( $\overline{HAK}$ ) pin in external bus mode. This pin functions as a general-purpose I/O port when the HDE bit in the EPCR register is "0".
91	P56	L	General purpose input/output port.
	RDY		Function as the external ready input (RDY) pin in external bus mode. This pin functions as a general-purpose I/O port when the RYE bit in the EPCR register is "0".
92	P57	L	General purpose input/output port.
	CLK		Function as the machine cycle clock output (CLK) pin in external bus mode. This pin functions as a general-purpose I/O port when the CKE bit in the EPCR register is "0".
21, 22	P60, P61	C	General purpose input/output port. (With stand voltage of 5 V)
	INT0, INT1		Function as external interrupt ch0 and ch1 input pins.

(Continued)

# MB90330 Series

Pin no. LQFP	Pin name	Circuit type*	Function
23	P62	C	General purpose input/output ports. (Withstand voltage of 5 V)
	INT2		Function as an external interrupt ch2 input pin.
	SIN		Simple serial I/O data input pin.
24	P63	C	General purpose input/output port. (Withstand voltage of 5 V)
	INT3		Function as an external interrupt ch3 input pin.
	SOT		Simple serial I/O data output pin.
25	P64	C	General purpose input/output port. (Withstand voltage of 5 V)
	INT4		Function as an external interrupt ch4 input pin.
	SCK		Simple serial I/O clock input/output pin.
26	P65	C	General purpose input/output port. (Withstand voltage of 5 V)
	INT5		Function as an external interrupt ch5 input pin.
	PWC		Function as the PWC input pin.
27	P66	C	General purpose input/output port. (Withstand voltage of 5 V)
	INT6		Function as an external interrupt ch6 input pin.
	SCL0		Function as the ch0 clock I/O pin for the I <sup>2</sup> C interface. Set port output to High-Z during I <sup>2</sup> C interface operations.
28	P67	C	General purpose input/output port. (Withstand voltage of 5 V)
	INT7		Function as an external interrupt ch7 input pin.
	SDA0		Function as the ch0 data I/O pin for the I <sup>2</sup> C interface. Set port output to High-Z during I <sup>2</sup> C interface operations.
39 to 46	P70 to P77	I	General purpose input/output port.
	AN0 to AN7		Function as input pins for analog ch0 to ch7.
48 to 55	P80 to P87	I	General purpose input/output port.
	AN8 to AN15		Function as input pins for analog ch8 to ch15.
29	P90	D	General purpose input/output port.
	SIN2		Function as a data input pin for UART ch2.
30	P91	D	General purpose input/output port.
	SOT2		Function as a data output pin for UART ch2.
31	P92	D	General purpose input/output port.
	SCK2		Function as a clock I/O pin for UART ch2.
32	P93	D	General purpose input/output port.
	SIN3		Function as a data input pin for UART ch3.
33	P94	D	General purpose input/output port.
	SOT3		Function as a data output pin for UART ch3.
34	P95	D	General purpose input/output port.
	SCK3		Function as a clock I/O pin for UART ch3.
35	P96	C	General purpose input/output port. (Withstand voltage of 5 V)
	ADTG		Function as the external trigger input pin when the A/D converter is being used.
	FRCK		Function as the external clock input pin when the free-run timer is being used.

(Continued)

# MB90330 Series

Pin no. LQFP	Pin name	Circuit type*	Function
56 to 59	PA0 to PA3	C	General purpose input/output port. (Withstand voltage of 5 V)
	IN0 to IN3		Function as the input capture ch0 to ch3 trigger inputs.
60 to 63	PA4 to PA7	C	General purpose input/output port. (Withstand voltage of 5 V)
	OUT0 to OUT3		Function as the output compare ch0 to ch3 event output pins.
64	PB0	C	General purpose input/output port. (Withstand voltage of 5 V)
	SCL1		Function as the ch1 clock I/O pin for the I <sup>2</sup> C interface. Set port output to High-Z during I <sup>2</sup> C interface operations.
65	PB1	C	General purpose input/output port. (Withstand voltage of 5 V)
	SDA1		Function as the ch1 data I/O pin for the I <sup>2</sup> C interface. Set port output to High-Z during I <sup>2</sup> C interface operations.
66	PB2	C	General purpose input/output port. (Withstand voltage of 5 V)
	SCL2		Function as the ch2 clock I/O pin for the I <sup>2</sup> C interface. Set port output to High-Z during I <sup>2</sup> C interface operations.
67	PB3	C	General purpose input/output port. (Withstand voltage of 5 V)
	SDA2		Function as the ch2 data I/O pin for the I <sup>2</sup> C interface. Set port output to High-Z during I <sup>2</sup> C interface operations.
68	PB4	C	General purpose input/output port. (Withstand voltage of 5 V)
69, 70	PB5, PB6	D	General purpose input/output port.
	PPG4, PPG5		Function as ch4 and ch5 output pins for the 8-bit PPG timer.
71	VBUS	C	Terminal for state detection of USB cable. (Withstand voltage of 5 V)
73	DVM	K	USB function D- pin.
74	DVP	K	USB function D+ pin.
77	HVM	K	USB Mini-HOST D- pin.
78	HVP	K	USB Mini-HOST D+ pin.
80	$\overline{\text{HCON}}$	E	External pull-up resistor connect pin.
36	AVcc	—	A/D converter power supply pin.
37	AVRH	J	A/D converter external reference power supply pin.
38	AVss	—	A/D converter power supply pin.
87 to 89	MD2 to MD0	B	Operation mode select input pin.
15	Vcc	—	Power supply pin.
75	Vcc	—	Power supply pin.
79	Vcc	—	Power supply pin.
105	Vcc	—	Power supply pin.
16	Vss	—	Power supply pin (GND).
47	Vss	—	Power supply pin (GND).
72	Vss	—	Power supply pin (GND).
76	Vss	—	Power supply pin (GND).
106	Vss	—	Power supply pin (GND).

\* : For circuit information, see “■ I/O CIRCUIT TYPE”.

# MB90330 Series

## ■ I/O CIRCUIT TYPE

Type	Circuit	Remarks
A		<ul style="list-style-type: none"> <li>• High-rate oscillation feedback resistor, approx.1 MΩ</li> <li>• Low-rate oscillation feedback resistor, approx.10 MΩ</li> <li>• With standby control</li> </ul>
B		<ul style="list-style-type: none"> <li>• CMOS hysteresis input</li> </ul>
C		<ul style="list-style-type: none"> <li>• CMOS hysteresis input</li> <li>• Nch open drain output</li> </ul>
D		<ul style="list-style-type: none"> <li>• CMOS output</li> <li>• CMOS hysteresis input (With input interception function at standby)</li> </ul> <p>Notes :</p> <ul style="list-style-type: none"> <li>• Share one output buffer because both output of I/O port and internal resource are used.</li> <li>• Share one input buffer because both input of I/O port and internal resource are used.</li> </ul>
E		<ul style="list-style-type: none"> <li>• CMOS output</li> </ul>
F		<ul style="list-style-type: none"> <li>• CMOS hysteresis input with pull-up resistor</li> </ul>

(Continued)

Type	Circuit	Remarks
G	<p>Open drain control signal</p> <p>Hysteresis input</p> <p>Standby control signal</p>	<ul style="list-style-type: none"> <li>• CMOS output</li> <li>• CMOS hysteresis input (With input interception function at standby)</li> <li>• With open drain control signal</li> </ul>
H	<p>CTL</p> <p>CMOS input</p> <p>Standby control signal</p>	<ul style="list-style-type: none"> <li>• CMOS output</li> <li>• CMOS input (With input interception function at standby)</li> <li>• With input pull-up register control</li> </ul>
I	<p>Hysteresis input</p> <p>Standby control signal</p> <p>A/D converter analog input</p>	<ul style="list-style-type: none"> <li>• CMOS output</li> <li>• CMOS hysteresis input (With input interception function at standby)</li> <li>• Analog input (The A/D converter analog input is enabled when the corresponding bit in the analog input enable register (ADER) is 1.)</li> </ul> <p>Notes:</p> <ul style="list-style-type: none"> <li>• Because the output of the I/O port and the output of internal resources are used combinedly, one output buffer is shared.</li> <li>• Because the input of the I/O port and the input of internal resources are used combinedly, one input buffer is shared.</li> </ul>
J	<p>AVRH input</p> <p>A/D converter analog input enable signal</p>	<ul style="list-style-type: none"> <li>• A/D converter (AVRH) voltage input pin</li> </ul>

(Continued)

# MB90330 Series

(Continued)

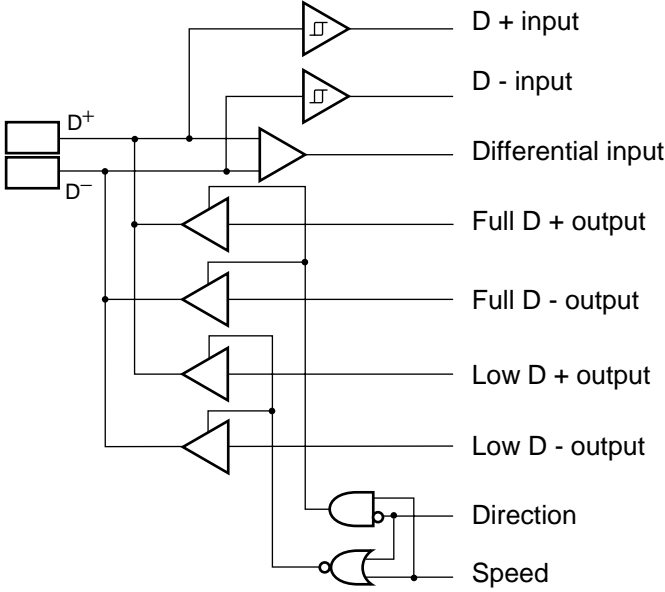
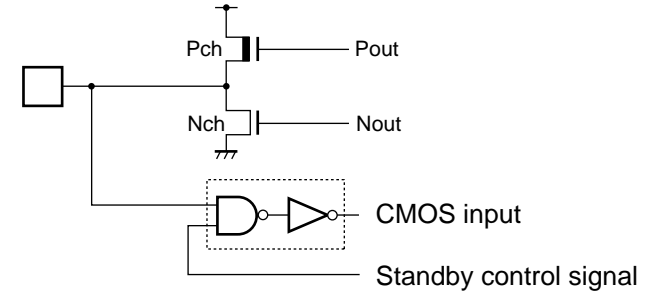
Type	Circuit	Remarks
K	 <p>The circuit diagram for Type K shows two differential inputs, D+ and D-, connected to a network of logic gates. The D+ input is connected to two inverters, which then connect to two more inverters, resulting in a differential input pair. The D- input is connected to a similar network. The outputs are labeled: D + input, D - input, Differential input, Full D + output, Full D - output, Low D + output, and Low D - output. The circuit is controlled by two signals: Direction (an AND gate) and Speed (an OR gate).</p>	<ul style="list-style-type: none"> <li>• USB I/O pin</li> </ul>
L	 <p>The circuit diagram for Type L shows a CMOS output stage with a PMOS transistor (Pch) and an NMOS transistor (Nch). The output is labeled Pout and Nout. The input is a CMOS input, which is connected to a standby control signal through an AND gate and an inverter.</p>	<ul style="list-style-type: none"> <li>• CMOS output</li> <li>• CMOS input</li> <li>• With standby control</li> </ul>

## ■ HANDLING DEVICES

### 1. Preventing latchup and turning on power supply

Latchup may occur on CMOS IC under the following conditions:

- If a voltage higher than  $V_{CC}$  or lower than  $V_{SS}$  is applied to input and output pins.
- A voltage higher than the rated voltage is applied between  $V_{CC}$  and  $V_{SS}$ .
- If the  $AV_{CC}$  power supply is turned on before the  $V_{CC}$  voltage.

Ensure that you apply a voltage to the analog power supply at the same time as  $V_{CC}$  or after you turn on the digital power supply (when you perform power-off, turn off the analog power supply first or at the same time as  $V_{CC}$  and the digital power supply).

If latch-up occurs, the supply current increases rapidly, sometimes resulting in thermal breakdown of the device. Use meticulous care not to let any voltage exceed the maximum rating.

### 2. Treatment of unused pins

Leaving unused input pins unconnected can cause abnormal operation or latchup, leading to permanent damage. Unused input pins should always be pulled up or down through resistance of at least 2 k $\Omega$ . Any unused input/output pins may be set to output mode and left open, or set to input mode and treated the same as unused input pins. If there is unused output pin, make it to open.

### 3. Treatment of power supply pins on models with A/D converters

Even when the A/D converters are not in use, be sure to make the necessary connections  $AV_{CC} = AVRH = V_{CC}$ , and  $AV_{SS} = V_{SS}$ .

### 4. About the attention when the external clock is used

- Using external clock

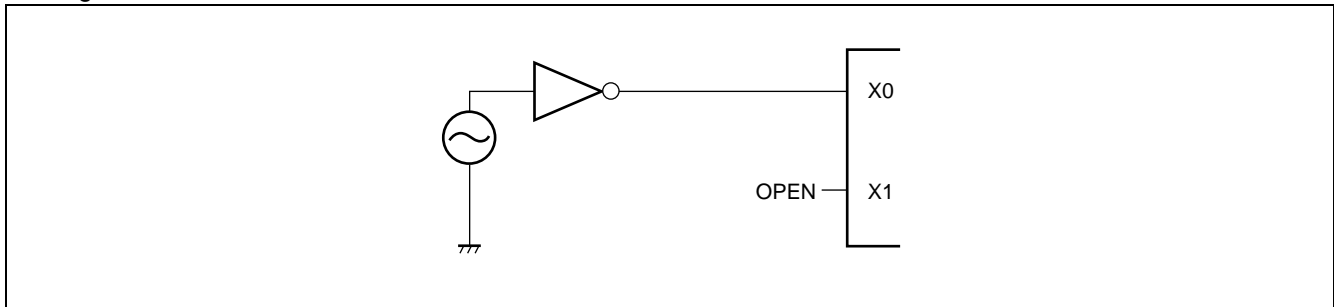

### 5. Treatment of power supply pins ( $V_{CC}/V_{SS}$ )

In products with multiple  $V_{CC}$  or  $V_{SS}$  pins, the pins of the same potential are internally connected in the device to avoid abnormal operations including latch-up. However, you must connect the pins to external power supply and a ground line to lower the electro-magnetic emission level, to prevent abnormal operation of strobe signals caused by the rise in the ground level, and to conform to the total output current rating.

Moreover, connect the current supply source with the  $V_{CC}$  and  $V_{SS}$  pins of this device at the low impedance.

It is also advisable to connect a ceramic bypass capacitor of approximately 0.1  $\mu\text{F}$  between  $V_{CC}$  and  $V_{SS}$  near this device.

### 6. About Crystal oscillator circuit

Noise near the X0/X1 pins and X0A/X1A pins may cause the device to malfunction. Design the printed circuit board so that X0/X1 pins and X0A/X1A pins, the crystal oscillator (or the ceramic oscillator) and the bypass capacitor to ground are located as close to the device as possible.

It is strongly recommended to design the PC board artwork with the X0/X1 pins and X0A/X1A pins surrounded by ground plane because stable operation can be expected with such a layout.

## 7. Caution on Operations during PLL Clock Mode

Even if the oscillator comes off or the clock input stops with the PLL clock selected for this microcontroller, the microcontroller may continue to operate at the free-running frequency of the PLL internal automatic oscillator circuit. Performance of this operation, however, cannot be guaranteed.

## 8. Stabilization of supply voltage

A sudden change in the supply voltage may cause the device to malfunction even within the  $V_{CC}$  supply voltage operating range. For stabilization reference, the supply voltage should be stabilized so that  $V_{CC}$  ripple variations (peak-to-peak value) at commercial frequencies (50 MHz to 60 MHz) fall below 10% of the standard  $V_{CC}$  supply voltage and the transient regulation does not exceed 0.1 V/ms at temporary changes such as power supply switching.

## 9. When the dual-supply is used as a single-supply device

If you are using only a single-system of the MB90330 series that come in the dual-system product, use it with  $X0A = VSS$  :  $X1A = OPEN$ .

## 10. Writing to flash memory

For serial writing to flash memory, always make sure that the operating voltage  $V_{CC}$  is between 3.13 V and 3.6 V.

For normal writing to flash memory, always make sure that the operating voltage  $V_{CC}$  is between 3.0 V and 3.6 V.



## ■ BLOCK DIAGRAM

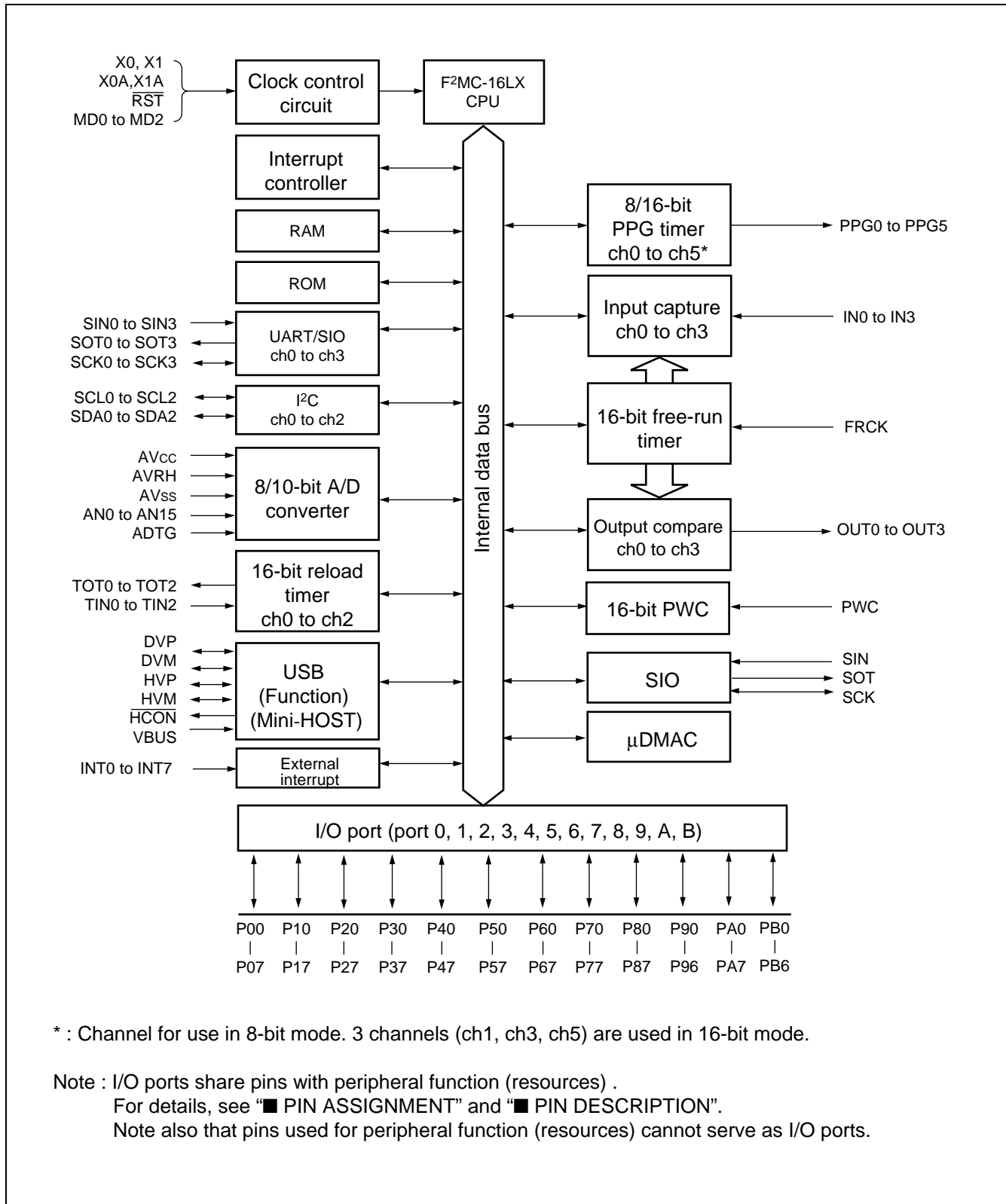

# MB90330 Series

## MEMORY MAP

Single chip mode (with ROM mirror function)

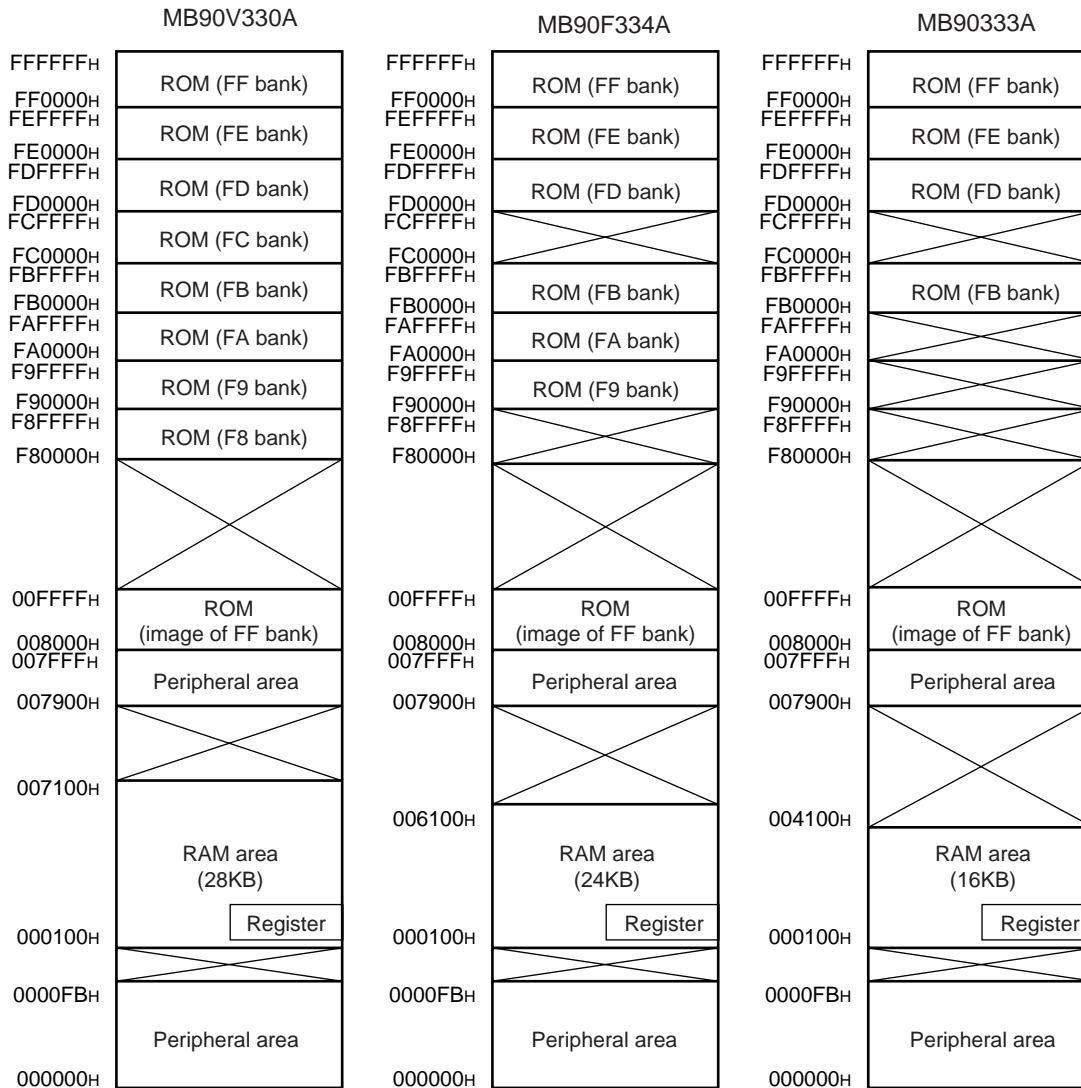

Memory map of MB90330 series (1/3)

## Internal ROM external bus mode (with ROM mirror function)

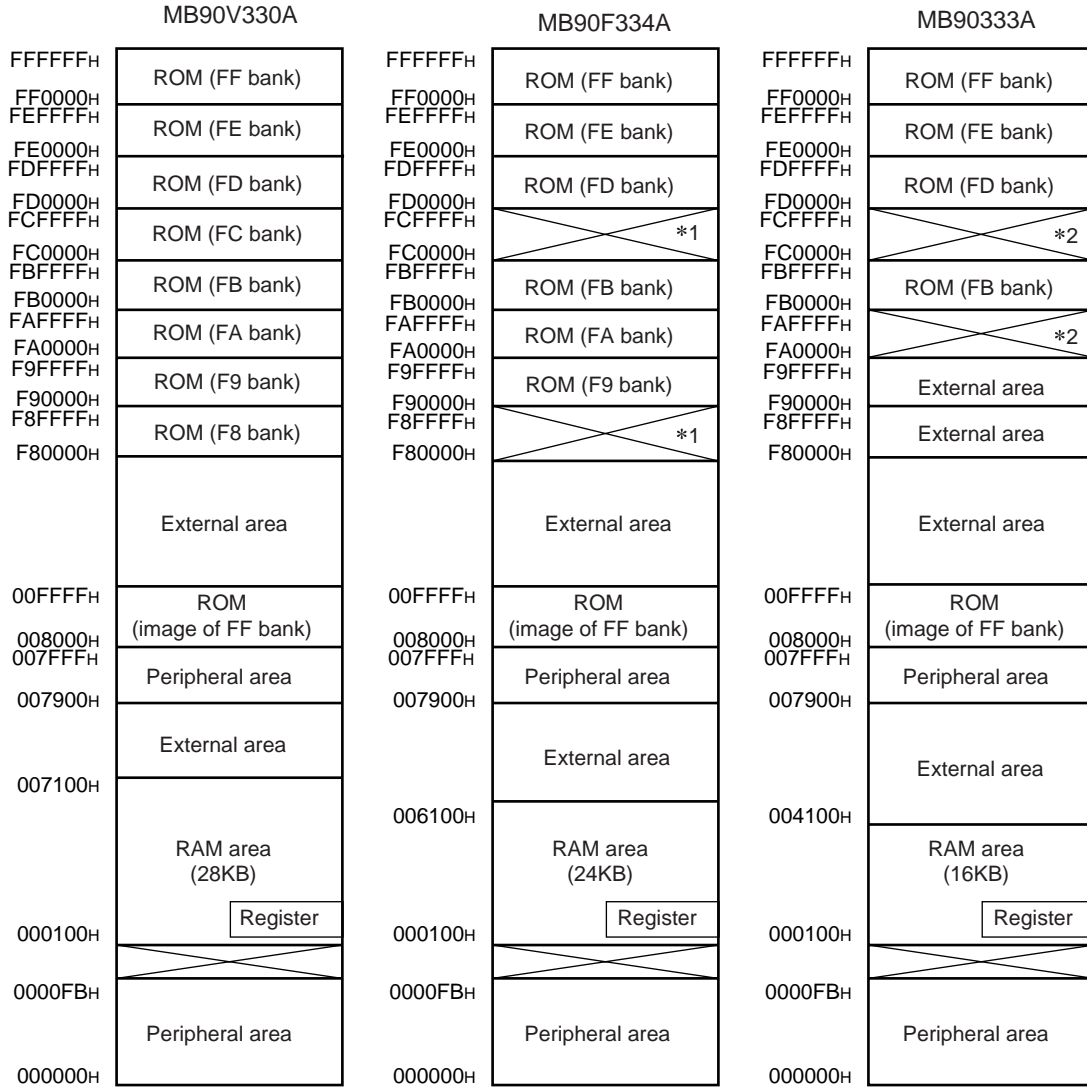

\*1 : In the area of F80000<sub>H</sub> to F8FFFF<sub>H</sub> and FC0000<sub>H</sub> to FCFFFF<sub>H</sub> at MB90F334, a value of "1" is read at read operating.

\*2 : In the area of FA0000<sub>H</sub> to FAFFFF<sub>H</sub> and FC0000<sub>H</sub> to FCFFFF<sub>H</sub> at MB90333, a value of "1" is read at read operating.

Memory map of MB90330 series (2/3)

# MB90330 Series

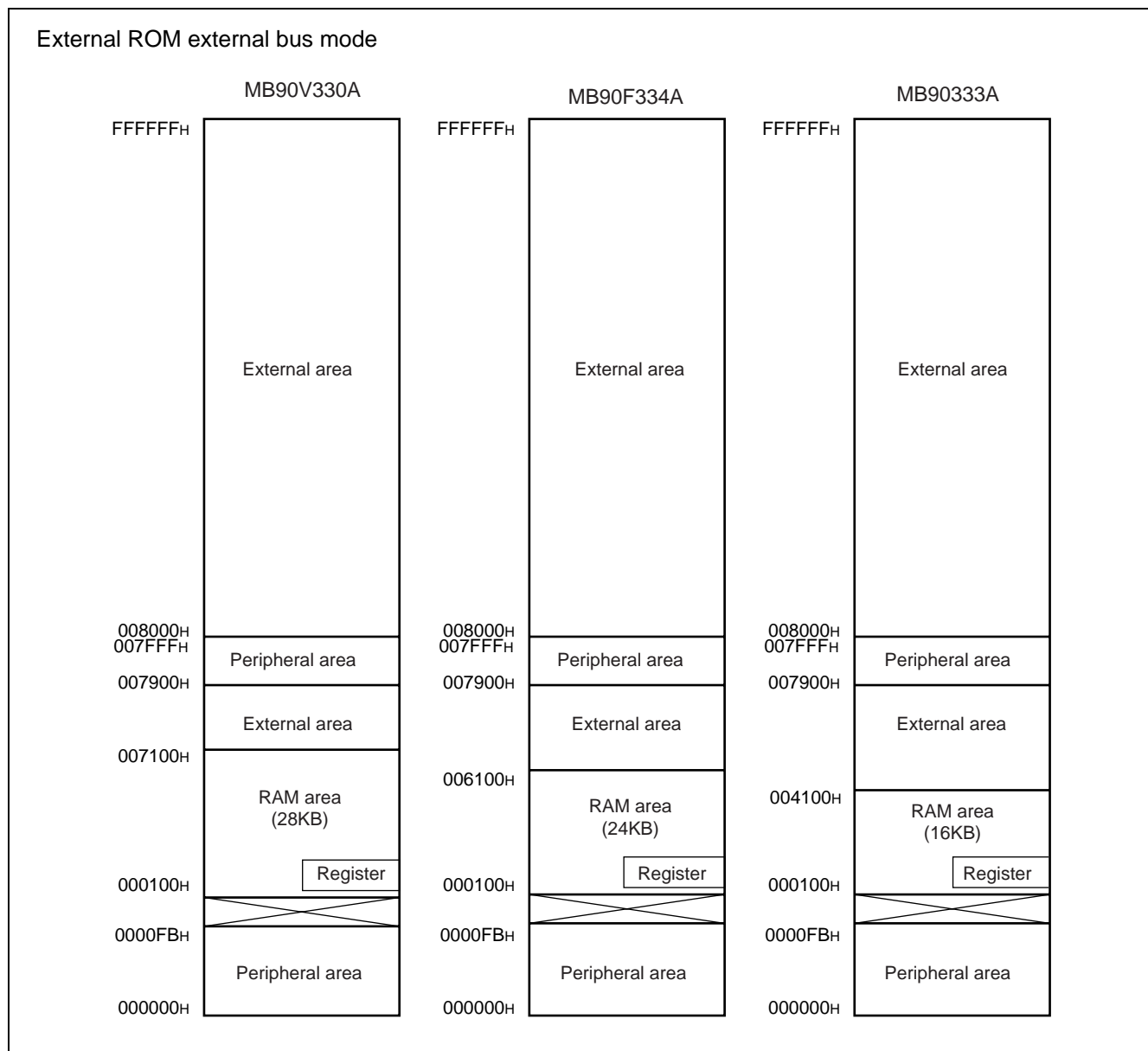

Memory map of MB90330 series (3/3)

- Notes :
- When the ROM mirror function register has been set, the mirror image data at higher addresses (“FF8000H to FFFFFFFH”) of bank FF is visible from the higher addresses (“008000H to 00FFFFH”) of bank 00.
  - The ROM mirror function is effective for using the C compiler small model.
  - The lower 16-bit addresses of bank FF are equivalent to those of bank 00. Since the ROM area in bank FF exceeds 48 KB, however, the mirror image of all the data in the ROM area cannot be reproduced in bank 00.
  - When the C compiler small model is used, the data table mirror image can be shown at “008000H to 00FFFFH” by storing the data table at “FF8000H to FFFFFFFH”. Therefore, data tables in the ROM area can be referred without declaring the far addressing with the pointer.

## ■ F<sup>2</sup>MC-16L CPU PROGRAMMING MODEL

### • Dedicated register

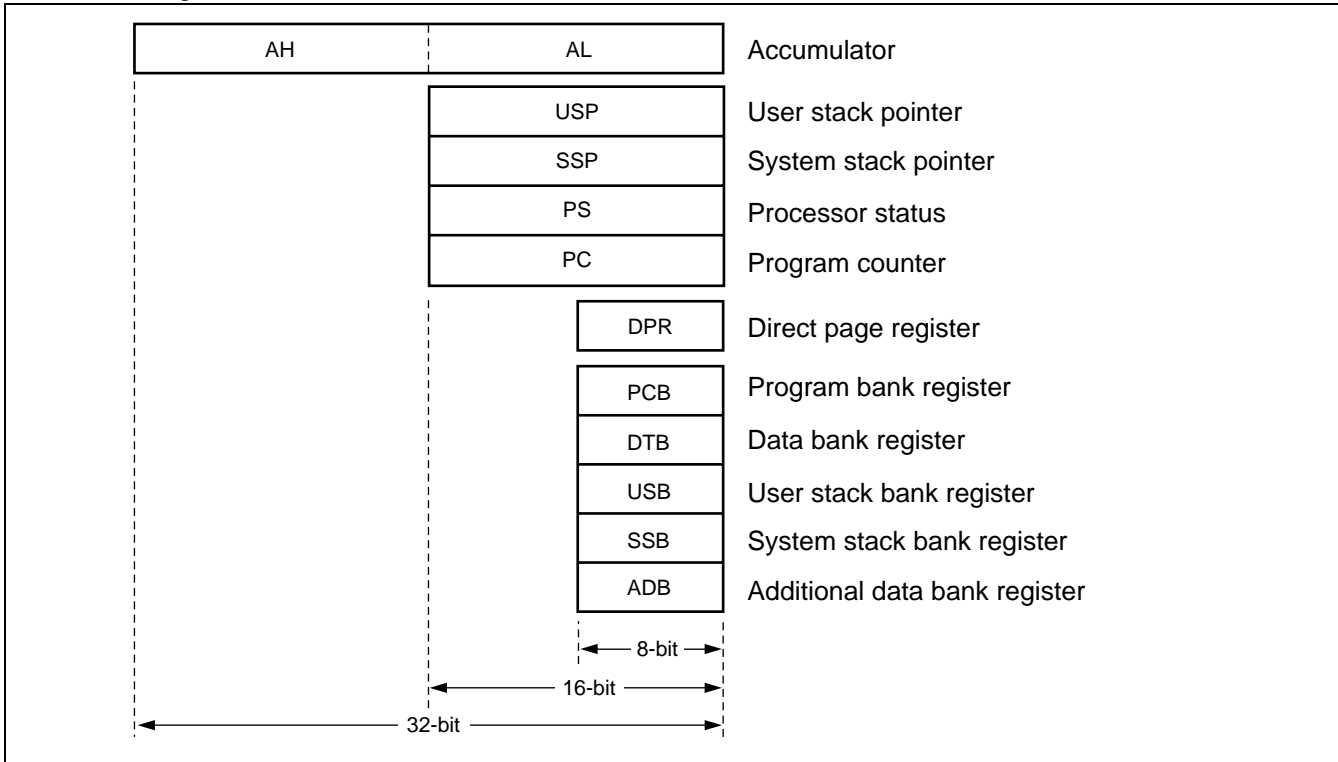

### • General purpose register

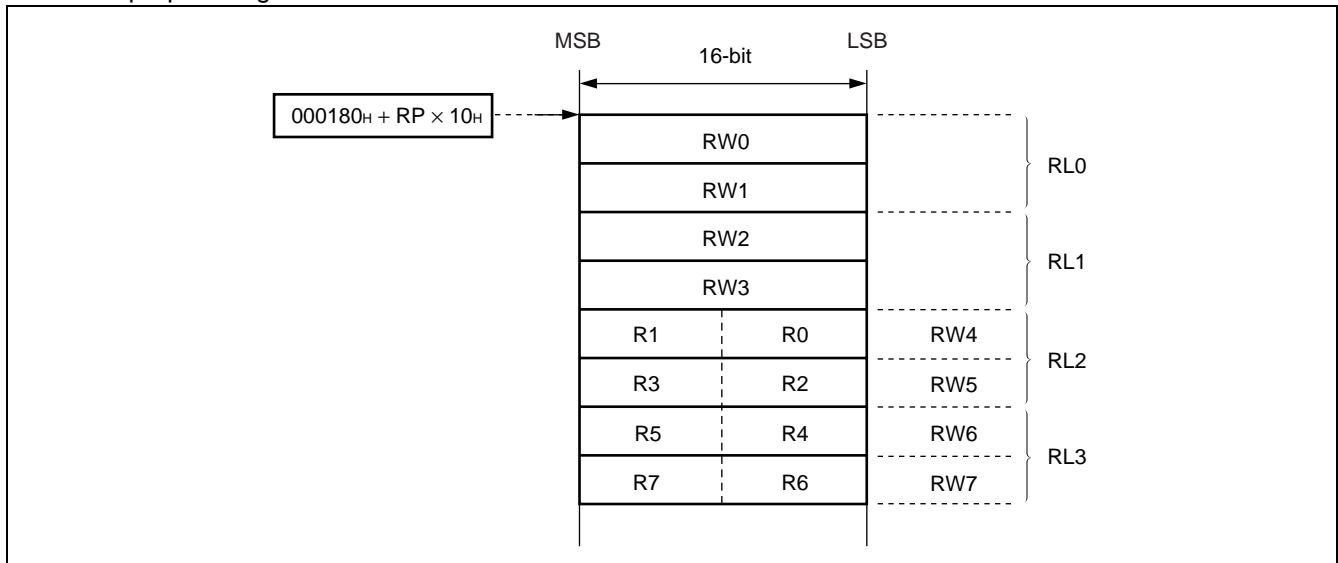

### • Processor status

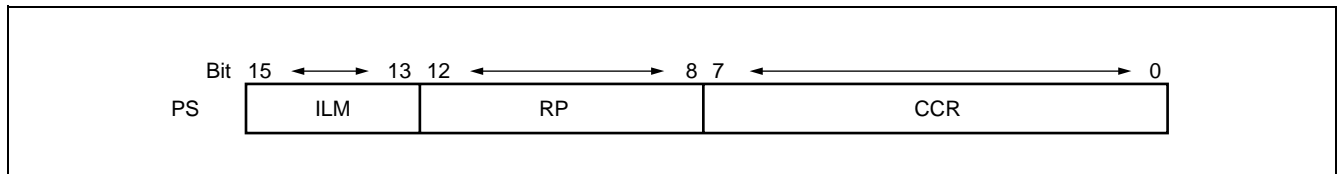

# MB90330 Series

## ■ I/O MAP

Address	Register abbreviation	Register	Read/Write	Resource name	Initial Value
000000 <sub>H</sub>	PDR0	Port 0 Data Register	R/W	Port 0	XXXXXXXX <sub>B</sub>
000001 <sub>H</sub>	PDR1	Port 1 Data Register	R/W	Port 1	XXXXXXXX <sub>B</sub>
000002 <sub>H</sub>	PDR2	Port 2 Data Register	R/W	Port 2	XXXXXXXX <sub>B</sub>
000003 <sub>H</sub>	PDR3	Port 3 Data Register	R/W	Port 3	XXXXXXXX <sub>B</sub>
000004 <sub>H</sub>	PDR4	Port 4 Data Register	R/W	Port 4	XXXXXXXX <sub>B</sub>
000005 <sub>H</sub>	PDR5	Port 5 Data Register	R/W	Port 5	XXXXXXXX <sub>B</sub>
000006 <sub>H</sub>	PDR6	Port 6 Data Register	R/W	Port 6	XXXXXXXX <sub>B</sub>
000007 <sub>H</sub>	PDR7	Port 7 Data Register	R/W	Port 7	XXXXXXXX <sub>B</sub>
000008 <sub>H</sub>	PDR8	Port 8 Data Register	R/W	Port 8	XXXXXXXX <sub>B</sub>
000009 <sub>H</sub>	PDR9	Port 9 Data Register	R/W	Port 9	-XXXXXXXX <sub>B</sub>
00000A <sub>H</sub>	PDRA	Port A Data Register	R/W	Port A	XXXXXXXX <sub>B</sub>
00000B <sub>H</sub>	Prohibited				
00000C <sub>H</sub>	PDRB	Port B Data Register	R/W	Port B	-XXXXXXXX <sub>B</sub>
00000D <sub>H</sub>	DDRB	Port B Direction Register	R/W	Port B	-0000000 <sub>B</sub>
00000E <sub>H</sub>	Prohibited				
00000F <sub>H</sub>	Prohibited				
000010 <sub>H</sub>	DDR0	Port 0 Direction Register	R/W	Port 0	00000000 <sub>B</sub>
000011 <sub>H</sub>	DDR1	Port 1 Direction Register	R/W	Port 1	00000000 <sub>B</sub>
000012 <sub>H</sub>	DDR2	Port 2 Direction Register	R/W	Port 2	00000000 <sub>B</sub>
000013 <sub>H</sub>	DDR3	Port 3 Direction Register	R/W	Port 3	00000000 <sub>B</sub>
000014 <sub>H</sub>	DDR4	Port 4 Direction Register	R/W	Port 4	00000000 <sub>B</sub>
000015 <sub>H</sub>	DDR5	Port 5 Direction Register	R/W	Port 5	00000000 <sub>B</sub>
000016 <sub>H</sub>	DDR6	Port 6 Direction Register	R/W	Port 6	00000000 <sub>B</sub>
000017 <sub>H</sub>	DDR7	Port 7 Direction Register	R/W	Port 7	00000000 <sub>B</sub>
000018 <sub>H</sub>	DDR8	Port 8 Direction Register	R/W	Port 8	00000000 <sub>B</sub>
000019 <sub>H</sub>	DDR9	Port 9 Direction Register	R/W	Port 9	-0000000 <sub>B</sub>
00001A <sub>H</sub>	DDRA	Port A Direction Register	R/W	Port A	00000000 <sub>B</sub>
00001B <sub>H</sub>	ODR4	Port 4 Output Pin Register	R/W	Port 4 (open drain control)	00000000 <sub>B</sub>
00001C <sub>H</sub>	RDR0	Port 0 Pull-up Resistance Register	R/W	Port 0 (PULL-UP)	00000000 <sub>B</sub>
00001D <sub>H</sub>	RDR1	Port 1 Pull-up Resistance Register	R/W	Port 1 (PULL-UP)	00000000 <sub>B</sub>
00001E <sub>H</sub>	ADER0	Analog Input Enable Register 0	R/W	Port 7, 8, A/D	11111111 <sub>B</sub>
00001F <sub>H</sub>	ADER1	Analog Input Enable Register 1	R/W	Port 7, 8, A/D	11111111 <sub>B</sub>
000020 <sub>H</sub>	SMR0	Serial Mode Register ch0	R/W	UART0	00100000 <sub>B</sub>
000021 <sub>H</sub>	SCR0	Serial Control Register ch0	R/W		00000100 <sub>B</sub>
000022 <sub>H</sub>	SIDR0	Serial Input Data Register ch0	R		XXXXXXXX <sub>B</sub>
	SODR0	Serial Output Data Register ch0	W		
000023 <sub>H</sub>	SSR0	Serial Status Register ch0	R/W		00001000 <sub>B</sub>
000024 <sub>H</sub>	UTRLR0	UART Prescaler Reload Register ch0	R/W	Communication	00000000 <sub>B</sub>
000025 <sub>H</sub>	UTCRC0	UART Prescaler Control Register ch0	R/W	Prescaler (UART0)	0000-000 <sub>B</sub>

(Continued)

# MB90330 Series

Address	Register abbreviation	Register	Read/Write	Resource name	Initial Value
000026 <sub>H</sub>	SMR1	Serial Mode Register ch1	R/W	UART1	00100000 <sub>B</sub>
000027 <sub>H</sub>	SCR1	Serial Control Register ch1	R/W		00000100 <sub>B</sub>
000028 <sub>H</sub>	SIDR1	Serial Input Data Register ch1	R		XXXXXXXX <sub>B</sub>
	SODR1	Serial Output Data Register ch1	W		
000029 <sub>H</sub>	SSR1	Serial Status Register ch1	R/W		00001000 <sub>B</sub>
00002A <sub>H</sub>	UTRLR1	UART Prescaler Reload Register ch1	R/W	Communication Prescaler (UART1)	00000000 <sub>B</sub>
00002B <sub>H</sub>	UTCR1	UART Prescaler Control Register ch1	R/W		0000-000 <sub>B</sub>
00002C <sub>H</sub>	SMR2	Serial Mode Register ch2	R/W	UART2	00100000 <sub>B</sub>
00002D <sub>H</sub>	SCR2	Serial Control Register ch2	R/W		00000100 <sub>B</sub>
00002E <sub>H</sub>	SIDR2	Serial Input Data Register ch2	R		XXXXXXXX <sub>B</sub>
	SODR2	Serial Output Data Register ch2	W		
00002F <sub>H</sub>	SSR2	Serial Status Register ch2	R/W		00001000 <sub>B</sub>
000030 <sub>H</sub>	UTRLR2	UART Prescaler Reload Register ch2	R/W	Communication Prescaler (UART2)	00000000 <sub>B</sub>
000031 <sub>H</sub>	UTCR2	UART Prescaler Control Register ch2	R/W		0000-000 <sub>B</sub>
000032 <sub>H</sub>	SMR3	Serial Mode Register ch3	R/W	UART3	00100000 <sub>B</sub>
000033 <sub>H</sub>	SCR3	Serial Control Register ch3	R/W		00000100 <sub>B</sub>
000034 <sub>H</sub>	SIDR3	Serial Input Data Register ch3	R		XXXXXXXX <sub>B</sub>
	SODR3	Serial Output Data Register ch3	W		
000035 <sub>H</sub>	SSR3	Serial Status Register ch3	R/W		00001000 <sub>B</sub>
000036 <sub>H</sub>	UTRLR3	UART Prescaler Reload Register ch3	R/W	Communication Prescaler (UART3)	00000000 <sub>B</sub>
000037 <sub>H</sub>	UTCR3	UART Prescaler Control Register ch3	R/W		0000-000 <sub>B</sub>
000038 <sub>H</sub> to 00003B <sub>H</sub>	Prohibited				
00003C <sub>H</sub>	ENIR	DTP/Interrupt Enable Register	R/W	DTP/External Interrupt	00000000 <sub>B</sub>
00003D <sub>H</sub>	EIRR	DTP/Interrupt Source Register	R/W		00000000 <sub>B</sub>
00003E <sub>H</sub>	ELVR	Request Level Setting Register Lower	R/W		00000000 <sub>B</sub>
00003F <sub>H</sub>		Request Level Setting Register Upper	R/W		00000000 <sub>B</sub>
000040 <sub>H</sub>	ADCS0	A/D Control Status Register Lower	R/W	8/10-bit A/D Converter	00-----0 <sub>B</sub>
000041 <sub>H</sub>	ADCS1	A/D Control Status Register Upper	R/W		00000000 <sub>B</sub>
000042 <sub>H</sub>	ADCR0	A/D Data Register Lower	R/W		XXXXXXXX <sub>B</sub>
000043 <sub>H</sub>	ADCR1	A/D Data Register Upper	R/W		00101XXX <sub>B</sub>
000044 <sub>H</sub>	Prohibited				
000045 <sub>H</sub>	ADMR	A/D Conversion Channel Selection Register	R/W	8/10-bit A/D Converter	00000000 <sub>B</sub>
000046 <sub>H</sub>	PPGC0	PPG0 Operation Mode Control Register	R/W	PPG ch0	0X000XX1 <sub>B</sub>
000047 <sub>H</sub>	PPGC1	PPG1 Operation Mode Control Register	R/W	PPG ch1	0X000001 <sub>B</sub>
000048 <sub>H</sub>	PPGC2	PPG2 Operation Mode Control Register	R/W	PPG ch2	0X000XX1 <sub>B</sub>

(Continued)

# MB90330 Series

Address	Register abbreviation	Register	Read/Write	Resource name	Initial Value
000049 <sub>H</sub>	PPGC3	PPG3 Operation Mode Control Register	R/W	PPG ch3	0X0 0 0 0 0 1 <sub>B</sub>
00004A <sub>H</sub>	PPGC4	PPG4 Operation Mode Control Register	R/W	PPG ch4	0X0 0 0XX1 <sub>B</sub>
00004B <sub>H</sub>	PPGC5	PPG5 Operation Mode Control Register	R/W	PPG ch5	0X0 0 0 0 0 1 <sub>B</sub>
00004C <sub>H</sub>	PPG01	PPG0 and PPG1 Output Control Register	R/W	PPG ch0/1	0 0 0 0 0 0XX <sub>B</sub>
00004D <sub>H</sub>	Prohibited				
00004E <sub>H</sub>	PPG23	PPG2 and PPG3 Output Control Register	R/W	PPG ch2/3	0 0 0 0 0 0 XX <sub>B</sub>
00004F <sub>H</sub>	Prohibited				
000050 <sub>H</sub>	PPG45	PPG4 and PPG5 Output Control Register	R/W	PPG ch4/5	0 0 0 0 0 0 XX <sub>B</sub>
000051 <sub>H</sub>	Prohibited				
000052 <sub>H</sub>	ICS01	Input Capture Control Status Register 01	R/W	Input Capture ch0/1	0 0 0 0 0 0 0 0 <sub>B</sub>
000053 <sub>H</sub>	ICS23	Input Capture Control Status Register 23	R/W	Input Capture ch2/3	0 0 0 0 0 0 0 0 <sub>B</sub>
000054 <sub>H</sub>	OCS0	Output Compare Control Register ch0 Lower	R/W	Output Compare ch0/1	0 0 0 0 - - 0 0 <sub>B</sub>
000055 <sub>H</sub>	OCS1	Output Compare Control Register ch1 Upper	R/W		- - - 0 0 0 0 0 0 <sub>B</sub>
000056 <sub>H</sub>	OCS2	Output Compare Control Register ch2 Lower	R/W	Output Compare ch2/3	0 0 0 0 - - 0 0 <sub>B</sub>
000057 <sub>H</sub>	OCS3	Output Compare Control Register ch3 Upper	R/W		- - - 0 0 0 0 0 0 <sub>B</sub>
000058 <sub>H</sub>	SMCS	Serial Mode Control Status Register	R/W	Extended Serial I/O	XXXX0 0 0 0 <sub>B</sub>
000059 <sub>H</sub>					0 0 0 0 0 0 1 0 <sub>B</sub>
00005A <sub>H</sub>	SDR	Serial Data Register	R/W		XXXXXXXX <sub>B</sub>
00005B <sub>H</sub>	SDCR	Communication Prescaler Control Register	R/W	Communication Prescaler	0XXX0 0 0 0 <sub>B</sub>
00005C <sub>H</sub>	PWCSR	PWC Control Status Register	R/W	16-bit PWC Timer	0 0 0 0 0 0 0 0 <sub>B</sub>
00005D <sub>H</sub>					0 0 0 0 0 0 0 X <sub>B</sub>
00005E <sub>H</sub>	PWCR	PWC Data Buffer Register	R/W		0 0 0 0 0 0 0 0 <sub>B</sub>
00005F <sub>H</sub>					0 0 0 0 0 0 0 0 <sub>B</sub>
000060 <sub>H</sub>	DIVR	PWC Dividing Ratio Register	R/W		- - - - - 0 0 <sub>B</sub>
000061 <sub>H</sub>	Prohibited				
000062 <sub>H</sub>	TMCSR0	Timer Control Status Register ch0	R/W	16-bit Reload Timer ch0	0 0 0 0 0 0 0 0 <sub>B</sub>
000063 <sub>H</sub>					XXXX 0 0 0 0 <sub>B</sub>
000064 <sub>H</sub>	TMR0	16-bit Timer Register ch0 Lower	R		XXXXXXXX <sub>B</sub>
	TMRLR0	16-bit Reload Register ch0 Lower	W		XXXXXXXX <sub>B</sub>
000065 <sub>H</sub>	TMR0	16-bit Timer Register ch0 Upper	R		XXXXXXXX <sub>B</sub>
	TMRLR0	16-bit Reload Register ch0 Upper	W		XXXXXXXX <sub>B</sub>

(Continued)



# MB90330 Series

Address	Register abbreviation	Register	Read/Write	Resource name	Initial Value	
000066 <sub>H</sub>	TMCSR1	Timer Control Status Register ch1	R/W	16-bit Reload Timer ch1	0 0 0 0 0 0 0 0 <sub>B</sub>	
000067 <sub>H</sub>					XXXX 0 0 0 0 <sub>B</sub>	
000068 <sub>H</sub>	TMR1	16-bit Timer Register ch1 Lower	R		XXXXXXXX <sub>B</sub>	
	TMRLR1	16-bit Reload Register ch1 Lower	W		XXXXXXXX <sub>B</sub>	
000069 <sub>H</sub>	TMR1	16-bit Timer Register ch1 Upper	R		XXXXXXXX <sub>B</sub>	
	TMRLR1	16-bit Reload Register ch1 Upper	W		XXXXXXXX <sub>B</sub>	
00006A <sub>H</sub>	TMCSR2	Timer Control Status Register ch2	R/W		16-bit Reload Timer ch2	0 0 0 0 0 0 0 0 <sub>B</sub>
00006B <sub>H</sub>						XXXX 0 0 0 0 <sub>B</sub>
00006C <sub>H</sub>	TMR2	16-bit Timer Register ch2 Lower	R	XXXXXXXX <sub>B</sub>		
	TMRLR2	16-bit Reload Register ch2 Lower	W	XXXXXXXX <sub>B</sub>		
00006D <sub>H</sub>	TMR2	16-bit Timer Register ch2 Upper	R	XXXXXXXX <sub>B</sub>		
	TMRLR2	16-bit Reload Register ch2 Upper	W	XXXXXXXX <sub>B</sub>		
00006E <sub>H</sub>	Prohibited					
00006F <sub>H</sub>	ROMM	ROM Mirror Function Selection Register	W	ROM Mirror Function Selection Module		----- 1 1 <sub>B</sub>
000070 <sub>H</sub>	IBSR0	I <sup>2</sup> C Bus Status Register ch0	R	I <sup>2</sup> C Bus Interface ch0	0 0 0 0 0 0 0 0 <sub>B</sub>	
000071 <sub>H</sub>	IBCR0	I <sup>2</sup> C Bus Control Register ch0	R/W		0 0 0 0 0 0 0 0 <sub>B</sub>	
000072 <sub>H</sub>	ICCR0	I <sup>2</sup> C Bus Clock Selection Register ch0	R/W		XX 0 XXXXX <sub>B</sub>	
000073 <sub>H</sub>	IADR0	I <sup>2</sup> C Bus Address Register ch0	R/W		XXXXXXXX <sub>B</sub>	
000074 <sub>H</sub>	IDAR0	I <sup>2</sup> C Bus Data Register ch0	R/W		XXXXXXXX <sub>B</sub>	
000075 <sub>H</sub>	Prohibited					
000076 <sub>H</sub>	IBSR1	I <sup>2</sup> C Bus Status Register ch1	R	I <sup>2</sup> C Bus Interface ch1	0 0 0 0 0 0 0 0 <sub>B</sub>	
000077 <sub>H</sub>	IBCR1	I <sup>2</sup> C Bus Control Register ch1	R/W		0 0 0 0 0 0 0 0 <sub>B</sub>	
000078 <sub>H</sub>	ICCR1	I <sup>2</sup> C Bus Clock Selection Register ch1	R/W		XX 0 XXXXX <sub>B</sub>	
000079 <sub>H</sub>	IADR1	I <sup>2</sup> C Bus Address Register ch1	R/W		XXXXXXXX <sub>B</sub>	
00007A <sub>H</sub>	IDAR1	I <sup>2</sup> C Bus Data Register ch1	R/W		XXXXXXXX <sub>B</sub>	
00007B <sub>H</sub>	Prohibited					
00007C <sub>H</sub>	IBSR2	I <sup>2</sup> C Bus Status Register ch2	R	I <sup>2</sup> C Bus Interface ch2	0 0 0 0 0 0 0 0 <sub>B</sub>	
00007D <sub>H</sub>	IBCR2	I <sup>2</sup> C Bus Control Register ch2	R/W		0 0 0 0 0 0 0 0 <sub>B</sub>	
00007E <sub>H</sub>	ICCR2	I <sup>2</sup> C Bus Clock Selection Register ch2	R/W		XX 0 XXXXX <sub>B</sub>	
00007F <sub>H</sub>	IADR2	I <sup>2</sup> C Bus Address Register ch2	R/W		XXXXXXXX <sub>B</sub>	
000080 <sub>H</sub>	IDAR2	I <sup>2</sup> C Bus Data Register ch2	R/W		XXXXXXXX <sub>B</sub>	
000081 <sub>H</sub> to 000085 <sub>H</sub>	Prohibited					

(Continued)

# MB90330 Series

Address	Register abbreviation	Register	Read/Write	Resource name	Initial Value
000086 <sub>H</sub>	TCDT	Timer Data Register Lower	R/W	16-bit Free-Run Timer	0 0 0 0 0 0 0 0 <sub>B</sub>
000087 <sub>H</sub>		Timer Data Register Upper	R/W		0 0 0 0 0 0 0 0 <sub>B</sub>
000088 <sub>H</sub>	TCCS	Timer Control Status Register Lower	R/W		0 0 0 0 0 0 0 0 <sub>B</sub>
000089 <sub>H</sub>		Timer Control Status Register Upper	R/W		0 - - 0 0 0 0 0 <sub>B</sub>
00008A <sub>H</sub>	CPCLR	Compare Clear Register Lower	R/W		XXXXXXXX <sub>B</sub>
00008B <sub>H</sub>		Compare Clear Register Upper	R/W		XXXXXXXX <sub>B</sub>
00008C <sub>H</sub> to 00009A <sub>H</sub>	Prohibited				
00009B <sub>H</sub>	DCSR	DMA Descriptor Channel Specification Register	R/W	μDMAC	0 0 0 0 0 0 0 0 <sub>B</sub>
00009C <sub>H</sub>	DSRL	DMA Status Register Lower	R/W		0 0 0 0 0 0 0 0 <sub>B</sub>
00009D <sub>H</sub>	DSRH	DMA Status Register Upper	R/W		0 0 0 0 0 0 0 0 <sub>B</sub>
00009E <sub>H</sub>	PACSR	Program Address Detection Control Status Register	R/W	Address Match Detection	0 0 0 0 0 0 0 0 <sub>B</sub>
00009F <sub>H</sub>	DIRR	Delay Interruption Factor Generation/Release Register	R/W	Delay Interrupt	- - - - - 0 <sub>B</sub>
0000A0 <sub>H</sub>	LPMCR	Low Power Consumption Mode Register	R/W	Low Power Consumption Control Circuit	0 0 0 1 1 0 0 0 <sub>B</sub>
0000A1 <sub>H</sub>	CKSCR	Clock Selection Register	R/W	Clock	1 1 1 1 1 1 0 0 <sub>B</sub>
0000A2 <sub>H</sub> 0000A3 <sub>H</sub>	Prohibited				
0000A4 <sub>H</sub>	DSSR	DMA Stop Status Register	R/W	μDMAC	0 0 0 0 0 0 0 0 <sub>B</sub>
0000A5 <sub>H</sub>	ARSR	Automatic Ready Function Selection Register	W	External Pin	0 0 1 1 - - 0 0 <sub>B</sub>
0000A6 <sub>H</sub>	HACR	External Address Output Control Register	W		* * * * * <sub>B</sub>
0000A7 <sub>H</sub>	EPCR	Bus Control Signal Control Register	W		1 0 0 0 * 1 0 - <sub>B</sub>
0000A8 <sub>H</sub>	WDTC	Watchdog Control Register	R/W	Watchdog Timer	X - XXX 1 1 1 <sub>B</sub>
0000A9 <sub>H</sub>	TBTC	Time-base Timer Control Register	R/W	Time-base Timer	1 - - 0 0 1 0 0 <sub>B</sub>
0000AA <sub>H</sub>	WTC	Watch Timer Control Register	R/W	Watch Timer	1 0 0 0 1 0 0 0 <sub>B</sub>
0000AB <sub>H</sub>	Prohibited				
0000AC <sub>H</sub>	DERL	DMA Enable Register Lower	R/W	μDMAC	0 0 0 0 0 0 0 0 <sub>B</sub>
0000AD <sub>H</sub>	DERH	DMA Enable Register Upper	R/W		0 0 0 0 0 0 0 0 <sub>B</sub>
0000AE <sub>H</sub>	FMCR	Flash Memory Control Status Register	R/W	Flash Memory I/F	0 0 0 X 0 0 0 0 <sub>B</sub>
0000AF <sub>H</sub>	Prohibited				

(Continued)

# MB90330 Series

Address	Register abbreviation	Register	Read/Write	Resource name	Initial Value
0000B0 <sub>H</sub>	ICR00	Interrupt Control Register 00	R/W	Interrupt Controller	0 0 0 0 0 1 1 1 <sub>B</sub>
0000B1 <sub>H</sub>	ICR01	Interrupt Control Register 01	R/W		0 0 0 0 0 1 1 1 <sub>B</sub>
0000B2 <sub>H</sub>	ICR02	Interrupt Control Register 02	R/W		0 0 0 0 0 1 1 1 <sub>B</sub>
0000B3 <sub>H</sub>	ICR03	Interrupt Control Register 03	R/W		0 0 0 0 0 1 1 1 <sub>B</sub>
0000B4 <sub>H</sub>	ICR04	Interrupt Control Register 04	R/W		0 0 0 0 0 1 1 1 <sub>B</sub>
0000B5 <sub>H</sub>	ICR05	Interrupt Control Register 05	R/W		0 0 0 0 0 1 1 1 <sub>B</sub>
0000B6 <sub>H</sub>	ICR06	Interrupt Control Register 06	R/W		0 0 0 0 0 1 1 1 <sub>B</sub>
0000B7 <sub>H</sub>	ICR07	Interrupt Control Register 07	R/W		0 0 0 0 0 1 1 1 <sub>B</sub>
0000B8 <sub>H</sub>	ICR08	Interrupt Control Register 08	R/W		0 0 0 0 0 1 1 1 <sub>B</sub>
0000B9 <sub>H</sub>	ICR09	Interrupt Control Register 09	R/W		0 0 0 0 0 1 1 1 <sub>B</sub>
0000BA <sub>H</sub>	ICR10	Interrupt Control Register 10	R/W		0 0 0 0 0 1 1 1 <sub>B</sub>
0000BB <sub>H</sub>	ICR11	Interrupt Control Register 11	R/W		0 0 0 0 0 1 1 1 <sub>B</sub>
0000BC <sub>H</sub>	ICR12	Interrupt Control Register 12	R/W		0 0 0 0 0 1 1 1 <sub>B</sub>
0000BD <sub>H</sub>	ICR13	Interrupt Control Register 13	R/W		0 0 0 0 0 1 1 1 <sub>B</sub>
0000BE <sub>H</sub>	ICR14	Interrupt Control Register 14	R/W		0 0 0 0 0 1 1 1 <sub>B</sub>
0000BF <sub>H</sub>	ICR15	Interrupt Control Register 15	R/W		0 0 0 0 0 1 1 1 <sub>B</sub>
0000C0 <sub>H</sub>	HCNT0	USB Host Control Register 0	R/W	USB Mini-HOST	0 0 0 0 0 0 0 0 <sub>B</sub>
0000C1 <sub>H</sub>	HCNT1	USB Host Control Register 1	R/W		0 0 0 0 0 0 0 1 <sub>B</sub>
0000C2 <sub>H</sub>	HIRQ	USB Host Interruption Register	R/W		0 0 0 0 0 0 0 0 <sub>B</sub>
0000C3 <sub>H</sub>	HERR	USB Host Error Status Register	R/W		0 0 0 0 0 0 1 1 <sub>B</sub>
0000C4 <sub>H</sub>	HSTATE	USB Host State Status Register	R/W		XX 0 1 0 0 1 0 <sub>B</sub>
0000C5 <sub>H</sub>	HFCOMP	USB SOF Interrupt FRAME Compare Register	R/W		0 0 0 0 0 0 0 0 <sub>B</sub>
0000C6 <sub>H</sub>	HRTIMER	USB Retry Timer Setting Register 0	R/W		0 0 0 0 0 0 0 0 <sub>B</sub>
0000C7 <sub>H</sub>		USB Retry Timer Setting Register 1	R/W		0 0 0 0 0 0 0 0 <sub>B</sub>
0000C8 <sub>H</sub>		USB Retry Timer Setting Register 2	R/W		XXXXXX 0 0 <sub>B</sub>
0000C9 <sub>H</sub>	HADR	USB Host Address Register	R/W		X 0 0 0 0 0 0 0 <sub>B</sub>
0000CA <sub>H</sub>	HEOF	USB EOF Setting Register 0	R/W		0 0 0 0 0 0 0 0 <sub>B</sub>
0000CB <sub>H</sub>		USB EOF Setting Register 1	R/W		XX 0 0 0 0 0 0 <sub>B</sub>
0000CC <sub>H</sub>	HFRAME	USB FRAME Setting Register 0	R/W		0 0 0 0 0 0 0 0 <sub>B</sub>
0000CD <sub>H</sub>		USB FRAME Setting Register 1	R/W		XXXXX 0 0 0 <sub>B</sub>
0000CE <sub>H</sub>	HTOKEN	USB Host Token End Point Register	R/W		0 0 0 0 0 0 0 0 <sub>B</sub>
0000CF <sub>H</sub>	Prohibited				
0000D0 <sub>H</sub>	UDCC	UDC Control Register	R/W	USB Function	1 0 1 0 0 0 0 0 <sub>B</sub>
0000D1 <sub>H</sub>	Prohibited				

(Continued)

# MB90330 Series

Address	Register abbreviation	Register	Read/Write	Resource name	Initial Value
0000D2 <sub>H</sub>	EP0C	EP0 Control Register	R/W	USB Function	X 1 0 0 0 0 0 0 <sub>B</sub>
0000D3 <sub>H</sub>			R/W		XXXX 0 0 0 X <sub>B</sub>
0000D4 <sub>H</sub>	EP1C	EP1 Control Register	R/W		0 0 0 0 0 0 0 0 <sub>B</sub>
0000D5 <sub>H</sub>			R/W		0 1 1 0 0 0 0 1 <sub>B</sub>
0000D6 <sub>H</sub>	EP2C	EP2 Control Register	R/W		0 1 0 0 0 0 0 0 <sub>B</sub>
0000D7 <sub>H</sub>			R/W		0 1 1 0 0 0 0 0 <sub>B</sub>
0000D8 <sub>H</sub>	EP3C	EP3 Control Register	R/W		0 1 0 0 0 0 0 0 <sub>B</sub>
0000D9 <sub>H</sub>			R/W		0 1 1 0 0 0 0 0 <sub>B</sub>
0000DA <sub>H</sub>	EP4C	EP4 Control Register	R/W		0 1 0 0 0 0 0 0 <sub>B</sub>
0000DB <sub>H</sub>			R/W		0 1 1 0 0 0 0 0 <sub>B</sub>
0000DC <sub>H</sub>	EP5C	EP5 Control Register	R/W		0 1 0 0 0 0 0 0 <sub>B</sub>
0000DD <sub>H</sub>			R/W		0 1 1 0 0 0 0 0 <sub>B</sub>
0000DE <sub>H</sub>	TMSP	Time Stamp Register	R		0 0 0 0 0 0 0 0 <sub>B</sub>
0000DF <sub>H</sub>			R/W		0 0 0 0 0 0 0 0 <sub>B</sub>
0000E0 <sub>H</sub>	UDCS	UDC Status Register	R/W		0 0 0 0 0 0 0 0 <sub>B</sub>
0000E1 <sub>H</sub>	UDCIE	UDC Interrupt Enable Register	R/W		0 0 0 0 0 0 0 0 <sub>B</sub>
0000E2 <sub>H</sub>	EP0IS	EP0I Status Register	R/W		XXXXXXXX <sub>B</sub>
0000E3 <sub>H</sub>			R/W		1 0 XXX 1 XX <sub>B</sub>
0000E4 <sub>H</sub>	EP0OS	EP0O Status Register	R/W		XXXXXXXX <sub>B</sub>
0000E5 <sub>H</sub>			R/W		1 0 0 XX 0 0 X <sub>B</sub>
0000E6 <sub>H</sub>	EP1S	EP1 Status Register	R		XXXXXXXX <sub>B</sub>
0000E7 <sub>H</sub>			R/W		1 0 0 0 0 0 0 X <sub>B</sub>
0000E8 <sub>H</sub>	EP2S	EP2 Status Register	R		XXXXXXXX <sub>B</sub>
0000E9 <sub>H</sub>			R/W		1 0 0 0 0 0 0 X <sub>B</sub>
0000EA <sub>H</sub>	EP3S	EP3 Status Register	R		XXXXXXXX <sub>B</sub>
0000EB <sub>H</sub>			R/W		1 0 0 0 0 0 0 X <sub>B</sub>
0000EC <sub>H</sub>	EP4S	EP4 Status Register	R		XXXXXXXX <sub>B</sub>
0000ED <sub>H</sub>			R/W		1 0 0 0 0 0 0 X <sub>B</sub>
0000EE <sub>H</sub>	EP5S	EP5 Status Register	R		XXXXXXXX <sub>B</sub>
0000EF <sub>H</sub>			R/W		1 0 0 0 0 0 0 X <sub>B</sub>
0000F0 <sub>H</sub>	EP0DT	EP0 Data Register	R/W		XXXXXXXX <sub>B</sub>
0000F1 <sub>H</sub>			R/W		XXXXXXXX <sub>B</sub>
0000F2 <sub>H</sub>	EP1DT	EP1 Data Register	R/W	XXXXXXXX <sub>B</sub>	
0000F3 <sub>H</sub>			R/W	XXXXXXXX <sub>B</sub>	
0000F4 <sub>H</sub>	EP2DT	EP2 Data Register	R/W	XXXXXXXX <sub>B</sub>	
0000F5 <sub>H</sub>			R/W	XXXXXXXX <sub>B</sub>	
0000F6 <sub>H</sub>	EP3DT	EP3 Data Register	R/W	XXXXXXXX <sub>B</sub>	
0000F7 <sub>H</sub>			R/W	XXXXXXXX <sub>B</sub>	

(Continued)

# MB90330 Series

Address	Register abbreviation	Register	Read/Write	Resource name	Initial Value
0000F8 <sub>H</sub>	EP4DT	EP4 Data Register	R/W	USB Function	XXXXXXXX <sub>B</sub>
0000F9 <sub>H</sub>			R/W		XXXXXXXX <sub>B</sub>
0000FA <sub>H</sub>	EP5DT	EP5 Data Register	R/W		XXXXXXXX <sub>B</sub>
0000FB <sub>H</sub>			R/W		XXXXXXXX <sub>B</sub>
0000FC <sub>H</sub> to 0000FF <sub>H</sub>	Prohibited				
000100 <sub>H</sub> to # <sub>H</sub>	RAM Area				
001FF0 <sub>H</sub>	PADR0	Program Address Detection Register ch0 Lower	R/W	Address Match Detection	XXXXXXXX <sub>B</sub>
001FF1 <sub>H</sub>		Program Address Detection Register ch0 Middle	R/W		XXXXXXXX <sub>B</sub>
001FF2 <sub>H</sub>		Program Address Detection Register ch0 Upper	R/W		XXXXXXXX <sub>B</sub>
001FF3 <sub>H</sub>	PADR1	Program Address Detection Register ch1 Lower	R/W		XXXXXXXX <sub>B</sub>
001FF4 <sub>H</sub>		Program Address Detection Register ch1 Middle	R/W		XXXXXXXX <sub>B</sub>
001FF5 <sub>H</sub>		Program Address Detection Register ch1 Upper	R/W		XXXXXXXX <sub>B</sub>
# <sub>H</sub> to 0078FF <sub>H</sub>	Unused Area				
007900 <sub>H</sub>	PRL0	PPG Reload Register Lower ch0	R/W	PPG ch0	XXXXXXXX <sub>B</sub>
007901 <sub>H</sub>	PRLH0	PPG Reload Register Upper ch0	R/W		XXXXXXXX <sub>B</sub>
007902 <sub>H</sub>	PRL1	PPG Reload Register Lower ch1	R/W	PPG ch1	XXXXXXXX <sub>B</sub>
007903 <sub>H</sub>	PRLH1	PPG Reload Register Upper ch1	R/W		XXXXXXXX <sub>B</sub>
007904 <sub>H</sub>	PRL2	PPG Reload Register Lower ch2	R/W	PPG ch2	XXXXXXXX <sub>B</sub>
007905 <sub>H</sub>	PRLH2	PPG Reload Register Upper ch2	R/W		XXXXXXXX <sub>B</sub>
007906 <sub>H</sub>	PRL3	PPG Reload Register Lower ch3	R/W	PPG ch3	XXXXXXXX <sub>B</sub>
007907 <sub>H</sub>	PRLH3	PPG Reload Register Upper ch3	R/W		XXXXXXXX <sub>B</sub>
007908 <sub>H</sub>	PRL4	PPG Reload Register Lower ch4	R/W	PPG ch4	XXXXXXXX <sub>B</sub>
007909 <sub>H</sub>	PRLH4	PPG Reload Register Upper ch4	R/W		XXXXXXXX <sub>B</sub>
00790A <sub>H</sub>	PRL5	PPG Reload Register Lower ch5	R/W	PPG ch5	XXXXXXXX <sub>B</sub>
00790B <sub>H</sub>	PRLH5	PPG Reload Register Upper ch5	R/W		XXXXXXXX <sub>B</sub>
00790C <sub>H</sub> to 00790F <sub>H</sub>	Prohibited				

(Continued)

# MB90330 Series

(Continued)

Address	Register abbreviation	Register	Read/Write	Resource name	Initial Value
007910 <sub>H</sub>	IPCP0	Input Capture Data Register Lower ch0	R	Input Capture ch0/1	XXXXXXXX <sub>B</sub>
007911 <sub>H</sub>		Input Capture Data Register Upper ch0	R		XXXXXXXX <sub>B</sub>
007912 <sub>H</sub>	IPCP1	Input Capture Data Register Lower ch1	R		XXXXXXXX <sub>B</sub>
007913 <sub>H</sub>		Input Capture Data Register Upper ch1	R		XXXXXXXX <sub>B</sub>
007914 <sub>H</sub>	IPCP2	Input Capture Data Register Lower ch2	R	Input Capture ch2/3	XXXXXXXX <sub>B</sub>
007915 <sub>H</sub>		Input Capture Data Register Upper ch2	R		XXXXXXXX <sub>B</sub>
007916 <sub>H</sub>	IPCP3	Input Capture Data Register Lower ch3	R		XXXXXXXX <sub>B</sub>
007917 <sub>H</sub>		Input Capture Data Register Upper ch3	R		XXXXXXXX <sub>B</sub>
007918 <sub>H</sub>	OCCP0	Output Compare Register Lower ch0	R/W	Output Compare ch0/1	XXXXXXXX <sub>B</sub>
007919 <sub>H</sub>		Output Compare Register Upper ch0	R/W		XXXXXXXX <sub>B</sub>
00791A <sub>H</sub>	OCCP1	Output Compare Register Lower ch1	R/W		XXXXXXXX <sub>B</sub>
00791B <sub>H</sub>		Output Compare Register Upper ch1	R/W		XXXXXXXX <sub>B</sub>
00791C <sub>H</sub>	OCCP2	Output Compare Register Lower ch2	R/W	Output Compare ch2/3	XXXXXXXX <sub>B</sub>
00791D <sub>H</sub>		Output Compare Register Upper ch2	R/W		XXXXXXXX <sub>B</sub>
00791E <sub>H</sub>	OCCP3	Output Compare Register Lower ch3	R/W		XXXXXXXX <sub>B</sub>
00791F <sub>H</sub>		Output Compare Register Upper ch3	R/W		XXXXXXXX <sub>B</sub>
007920 <sub>H</sub>	DBAPL	DMA Buffer Address Pointer Lower 8-bit	R/W	μDMAC	XXXXXXXX <sub>B</sub>
007921 <sub>H</sub>	DBAPM	DMA Buffer Address Pointer Middle 8-bit	R/W		XXXXXXXX <sub>B</sub>
007922 <sub>H</sub>	DBAPH	DMA Buffer Address Pointer Upper 8-bit	R/W		XXXXXXXX <sub>B</sub>
007923 <sub>H</sub>	DMACS	DMA Control Register	R/W		XXXXXXXX <sub>B</sub>
007924 <sub>H</sub>	DIOAL	DMA I/O Register Address Pointer Lower 8-bit	R/W		XXXXXXXX <sub>B</sub>
007925 <sub>H</sub>	DIOAH	DMA I/O Register Address Pointer Upper 8-bit	R/W		XXXXXXXX <sub>B</sub>
007926 <sub>H</sub>	DDCTL	DMA Data Counter Lower 8-bit	R/W		XXXXXXXX <sub>B</sub>
007927 <sub>H</sub>	DDCTH	DMA Data Counter Upper 8-bit	R/W		XXXXXXXX <sub>B</sub>
007928 <sub>H</sub> to 007FFF <sub>H</sub>	Prohibited				

- Explanation on read/write  
R/W : Readable and Writable  
R : Read only  
W : Write only

- Explanation on initial values  
0 : Initial value is "0".  
1 : Initial value is "1".  
X : Initial value is undefined.  
- : Initial value is undefined (None) .  
\* : Initial value of this bit is "1" or "0".

Note : No I/O instruction can be used for registers located between 007900<sub>H</sub> and 007FFF<sub>H</sub>.

## ■ INTERRUPT SOURCES, INTERRUPT VECTORS, AND INTERRUPT CONTROL REGISTERS

Interrupt source	EI <sup>2</sup> OS support	μDMAC	Interrupt vector		Interrupt control register		Priority	
			Number*	Address	ICR	Address		
Reset	×	×	#08	08 <sub>H</sub>	FFFFDC <sub>H</sub>	—	—	<div style="display: flex; align-items: center;"> <span style="font-size: 2em; margin-right: 5px;">↑</span> <span style="font-size: 2em; margin-left: 5px;">↓</span> </div>
INT 9 instruction	×	×	#09	09 <sub>H</sub>	FFFFD8 <sub>H</sub>	—	—	
Exceptional treatment	×	×	#10	0A <sub>H</sub>	FFFFD4 <sub>H</sub>	—	—	
USB Function1	×	0, 1	#11	0B <sub>H</sub>	FFFFD0 <sub>H</sub>	ICR00	0000B0 <sub>H</sub>	
USB Function2	×	2 to 6	#12	0C <sub>H</sub>	FFFFCC <sub>H</sub>			
USB Function3	×	×	#13	0D <sub>H</sub>	FFFFC8 <sub>H</sub>	ICR01	0000B1 <sub>H</sub>	
USB Function4	×	×	#14	0E <sub>H</sub>	FFFFC4 <sub>H</sub>			
USB Mini-HOST1	×	×	#15	0F <sub>H</sub>	FFFFC0 <sub>H</sub>	ICR02	0000B2 <sub>H</sub>	
USB Mini-HOST2	×	×	#16	10 <sub>H</sub>	FFFFBC <sub>H</sub>			
I <sup>2</sup> C ch0	×	×	#17	11 <sub>H</sub>	FFFFB8 <sub>H</sub>	ICR03	0000B3 <sub>H</sub>	
DTP/External interrupt ch0/1	○	×	#18	12 <sub>H</sub>	FFFFB4 <sub>H</sub>			
I <sup>2</sup> C ch1	×	×	#19	13 <sub>H</sub>	FFFFB0 <sub>H</sub>	ICR04	0000B4 <sub>H</sub>	
DTP/External interrupt ch2/3	○	×	#20	14 <sub>H</sub>	FFFFAC <sub>H</sub>			
I <sup>2</sup> C ch2	×	×	#21	15 <sub>H</sub>	FFFFA8 <sub>H</sub>	ICR05	0000B5 <sub>H</sub>	
DTP/External interrupt ch4/5	○	×	#22	16 <sub>H</sub>	FFFFA4 <sub>H</sub>			
PWC/Reload timer ch0	△	14	#23	17 <sub>H</sub>	FFFFA0 <sub>H</sub>	ICR06	0000B6 <sub>H</sub>	
DTP/External interrupt ch6/7	△	×	#24	18 <sub>H</sub>	FFFF9C <sub>H</sub>			
Input capture ch0/1	△	7	#25	19 <sub>H</sub>	FFFF98 <sub>H</sub>	ICR07	0000B7 <sub>H</sub>	
Reload timer ch1	△	×	#26	1A <sub>H</sub>	FFFF94 <sub>H</sub>			
Input capture ch2/3	△	8	#27	1B <sub>H</sub>	FFFF90 <sub>H</sub>	ICR08	0000B8 <sub>H</sub>	
Reload timer ch2	△	×	#28	1C <sub>H</sub>	FFFF8C <sub>H</sub>			
Output compare ch0/1	○	×	#29	1D <sub>H</sub>	FFFF88 <sub>H</sub>	ICR09	0000B9 <sub>H</sub>	
PPG ch0/1	×	×	#30	1E <sub>H</sub>	FFFF84 <sub>H</sub>			
Output compare ch2/3	○	×	#31	1F <sub>H</sub>	FFFF80 <sub>H</sub>	ICR10	0000BA <sub>H</sub>	
PPG ch2/3	×	×	#32	20 <sub>H</sub>	FFFF7C <sub>H</sub>			
UART (Send completed) ch2/3	○	11	#33	21 <sub>H</sub>	FFFF78 <sub>H</sub>	ICR11	0000BB <sub>H</sub>	
PPG ch4/5	×	×	#34	22 <sub>H</sub>	FFFF74 <sub>H</sub>			
UART (Reception completed) ch2/3	◎	10	#35	23 <sub>H</sub>	FFFF70 <sub>H</sub>	ICR12	0000BC <sub>H</sub>	
A/D converter/Free-run timer	△	15	#36	24 <sub>H</sub>	FFFF6C <sub>H</sub>			
UART (Send completed) ch0/1	○	13	#37	25 <sub>H</sub>	FFFF68 <sub>H</sub>	ICR13	0000BD <sub>H</sub>	
Extended serial I/O	×	9	#38	26 <sub>H</sub>	FFFF64 <sub>H</sub>			
UART (Reception completed) ch0/1	◎	12	#39	27 <sub>H</sub>	FFFF60 <sub>H</sub>	ICR14	0000BE <sub>H</sub>	
Time-base timer/Watch timer	×	×	#40	28 <sub>H</sub>	FFFF5C <sub>H</sub>			
Flash memory status	×	×	#41	29 <sub>H</sub>	FFFF58 <sub>H</sub>	ICR15	0000BF <sub>H</sub>	
Delay interrupt output module	×	×	#42	2A <sub>H</sub>	FFFF54 <sub>H</sub>			

(Continued)

# MB90330 Series

(Continued)

- ◎ : Available, EI<sup>2</sup>OS stop function provided (The interrupt request flag is cleared by the interrupt clear signal. With a stop request).
- : Available (The interrupt request flag is cleared by the interrupt clear signal.)
- △ : Available when any interrupt source sharing ICR is not used.
- × : Unavailable

\* : If the same level interrupt is output simultaneously, the lower interrupt factor of interrupt vector number has priority.

- Notes :
- If the same interrupt control register (ICR) has two interrupt factors and the use of the EI<sup>2</sup>OS is permitted, the EI<sup>2</sup>OS is activated when either of the factors is detected. As any interrupt other than the activation factor is masked while the EI<sup>2</sup>OS is running, it is recommended that you should mask either of the interrupt requests when using the EI<sup>2</sup>OS.
  - The interrupt flag is cleared by the EI<sup>2</sup>OS interrupt clear signal for the resource that has two interrupt factors in the same interrupt control register (ICR).
  - If a resource has two interrupt sources for the same interrupt number, both of the interrupt request flags are cleared by the  $\mu$ DMAC interrupt clear signal. Therefore, when you use either of two interrupt factors for the DMAC function, another interrupt function is disabled. Set the interrupt request permission bit to "0" in the appropriate resource, and take measures by software polling.

## • Content of USB interruption factor

USB interrupt factor	Details
USB function 1	End Point0-IN End Point0-OUT
USB function 2	End Point1-5
USB function 3	VOFF VON SUSP SOF BRST WKUP CONF
USB function 4	SPK
USB Mini-HOST1	DIRQ CNNIRQ URIRQ RWKIRQ
USB Mini-HOST2	SOFIRQ CMPIRQ



## ■ PERIPHERAL RESOURCES

### 1. I/O port

The I/O ports are used as general-purpose input/output ports (parallel I/O ports). MB90330 series model is provided with 12 ports (94 inputs) . The ports function as input/output pins for peripheral functions also.

The port data register (PDR) can be used to send output data to the I/O pin and to receive the signal input to the I/O port. The port direction register (DDR) can be used to set the I/O direction of the I/O pin in bit units.

The following table lists the I/O ports and the peripheral functions with which they share pins.

	Port Pin Name	Pin Name (Peripheral)	Peripheral Function that Shares Pin
Port 0	P00 to P07	—	(External bus)
Port 1	P10 to P17	—	(External bus)
Port 2	P20 to P23	—	(External bus)
	P24 to P27	PPG0 to PPG3	8/16-bit PPG timer 0, 1 (External bus)
Port 3	P30 to P33	TIN1, TOT1, TIN2, TOT2	16-bit Reload timer 1, 2 (External bus)
	P34 to P37	—	(External bus)
Port 4	P40, P41	TIN0, TOT0	16-bit Reload timer 0 (External bus)
	P42 to P47	SIN0, SOT0, SCK0, SIN1, SOT1, SCK1	UART0, UART1 (External bus)
Port 5	P50 to P57	—	(External bus)
Port 6	P60, P61	INT0, INT1	External interrupt
	P62 to P64	INT2 to INT4, SIN, SOT, SCK	External interrupt, Serial I/O
	P65	INT5, PWC	External interrupt, PWC
	P66, P67	INT6, INT7, SCL0, SDA0	External interrupt, I <sup>2</sup> C 0
Port 7	P70 to P77	AN0 to AN7	8/10-bit A/D converter
Port 8	P80 to P87	AN8 to AN15	8/10-bit A/D converter
Port 9	P90 to P95	SIN2, SOT2, SCK2, SIN3, SOT3, SCK3	UART2, 3
	P96	ADTG, FRCK	8/10-bit A/D converter, Free-run timer
Port A	PA0 to PA3	IN0 to IN3	Input capture 0, 1, 2, 3
	PA4 to PA7	OUT0 to OUT3	Output compare 0, 1, 2, 3
Port B	PB0 to PB3	SCL1, SDA1, SCL2, SDA2	I <sup>2</sup> C 1, 2
	PB4	—	—
	PB5, PB6	PPG4, PPG5	PPG timer 2

Note : These pins also serve as the analog input pins for ports 7 and 8. To use them as general-purpose ports, be sure to set the corresponding bits in the analog input enable register (ADER) to 0<sub>b</sub>. The ADER is initialized to FF<sub>H</sub> at a reset.

# MB90330 Series

## • Register list (port data register)

Register Name	Bit 7	Bit 6	Bit 5	Bit 4	Bit 3	Bit 2	Bit 1	Bit 0	Initial Value	Access
PDR0 Address : 000000H	P07	P06	P05	P04	P03	P02	P01	P00	XXXXXXXX <sub>B</sub>	R/W*
PDR1 Address : 000001H	P17	P16	P15	P14	P13	P12	P11	P10	XXXXXXXX <sub>B</sub>	R/W*
PDR2 Address : 000002H	P27	P26	P25	P24	P23	P22	P21	P20	XXXXXXXX <sub>B</sub>	R/W*
PDR3 Address : 000003H	P37	P36	P35	P34	P33	P32	P31	P30	XXXXXXXX <sub>B</sub>	R/W*
PDR4 Address : 000004H	P47	P46	P45	P44	P43	P42	P41	P40	XXXXXXXX <sub>B</sub>	R/W*
PDR5 Address : 000005H	P57	P56	P55	P54	P53	P52	P51	P50	XXXXXXXX <sub>B</sub>	R/W*
PDR6 Address : 000006H	P67	P66	P65	P64	P63	P62	P61	P60	XXXXXXXX <sub>B</sub>	R/W*
PDR7 Address : 000007H	P77	P76	P75	P74	P73	P72	P71	P70	XXXXXXXX <sub>B</sub>	R/W*
PDR8 Address : 000008H	P87	P86	P85	P84	P83	P82	P81	P80	XXXXXXXX <sub>B</sub>	R/W*
PDR9 Address : 000009H	—	P96	P95	P94	P93	P92	P91	P90	-XXXXXXXX <sub>B</sub>	R/W*
PDRA Address : 00000AH	PA7	PA6	PA5	PA4	PA3	PA2	PA1	PA0	XXXXXXXX <sub>B</sub>	R/W*
PDRB Address : 00000CH	—	PB6	PB5	PB4	PB3	PB2	PB1	PB0	-XXXXXXXX <sub>B</sub>	R/W*

\* : R/W access to I/O ports is a bit different in behavior from R/W access to memory as follows :

- Input mode

Read : The level at the relevant pin is read.

Write : Data is written to the output latch.

- Output mode

Read : The data register latch value is read.

Write : Data is output to the relevant pin.

• Register list (port direction register)

DDR0	7	6	5	4	3	2	1	0	Initial Value	Access
Address : 000010 <sub>H</sub>	D07	D06	D05	D04	D03	D02	D01	D00	00000000 <sub>B</sub>	R/W
DDR1	15	14	13	12	11	10	9	8		
Address : 000011 <sub>H</sub>	D17	D16	D15	D14	D13	D12	D11	D10	00000000 <sub>B</sub>	R/W
DDR2	7	6	5	4	3	2	1	0		
Address : 000012 <sub>H</sub>	D27	D26	D25	D24	D23	D22	D21	D20	00000000 <sub>B</sub>	R/W
DDR3	15	14	13	12	11	10	9	8		
Address : 000013 <sub>H</sub>	D37	D36	D35	D34	D33	D32	D31	D30	00000000 <sub>B</sub>	R/W
DDR4	7	6	5	4	3	2	1	0		
Address : 000014 <sub>H</sub>	D47	D46	D45	D44	D43	D42	D41	D40	00000000 <sub>B</sub>	R/W
DDR5	15	14	13	12	11	10	9	8		
Address : 000015 <sub>H</sub>	D57	D56	D55	D54	D53	D52	D51	D50	00000000 <sub>B</sub>	R/W
DDR6	7	6	5	4	3	2	1	0		
Address : 000016 <sub>H</sub>	D67	D66	D65	D64	D63	D62	D61	D60	00000000 <sub>B</sub>	R/W
DDR7	15	14	13	12	11	10	9	8		
Address : 000017 <sub>H</sub>	D77	D76	D75	D74	D73	D72	D71	D70	00000000 <sub>B</sub>	R/W
DDR8	7	6	5	4	3	2	1	0		
Address : 000018 <sub>H</sub>	D87	D86	D85	D84	D83	D82	D81	D80	00000000 <sub>B</sub>	R/W
DDR9	15	14	13	12	11	10	9	8		
Address : 000019 <sub>H</sub>	—	D96	D95	D94	D93	D92	D91	D90	-00000000 <sub>B</sub>	R/W
DDRA	7	6	5	4	3	2	1	0		
Address : 00001A <sub>H</sub>	DA7	DA6	DA5	DA4	DA3	DA2	DA1	DA0	00000000 <sub>B</sub>	R/W
DDRB	15	14	13	12	11	10	9	8		
Address : 00000D <sub>H</sub>	—	DB6	DB5	DB4	DB3	DB2	DB1	DB0	-00000000 <sub>B</sub>	R/W

- When each pin is serving as a port, the corresponding pin is controlled as follows :

0 : Input mode

1 : Output mode

This bit becomes 0 after a reset.

Note : If these registers are accessed by a read modify write instruction (such as a bit set instruction) , the bits manipulated by the instruction are set to prescribed values but those other bits in output registers which have been set for input are rewritten to current input values of the pins. When switching a pin from input port to output port, therefore, write a desired value in the PDR first, then set the DDR to switch the pin for output.

# MB90330 Series

• Register list (Analog input enable register)

ADER0	7	6	5	4	3	2	1	0	Initial Value	Access
Address : 00001E <sub>H</sub>	ADE7	ADE6	ADE5	ADE4	ADE3	ADE2	ADE1	ADE0	11111111 <sub>B</sub>	R/W
ADER1	15	14	13	12	11	10	9	8	Initial Value	Access
Address : 00001F <sub>H</sub>	ADE15	ADE14	ADE13	ADE12	ADE11	ADE10	ADE9	ADE8	11111111 <sub>B</sub>	R/W

This register controls the port 7, 8 pins as follows.

0 : Port input/output mode.

1 : Analog input mode.

This bit becomes 1 after a reset.

• Register list (Port pull-up resistance register)

RDR0	7	6	5	4	3	2	1	0	Initial Value	Access
Address : 00001C <sub>H</sub>	RD07	RD06	RD05	RD04	RD03	RD02	RD01	RD00	00000000 <sub>B</sub>	R/W
RDR1	15	14	13	12	11	10	9	8	Initial Value	Access
Address : 00001D <sub>H</sub>	RD17	RD16	RD15	RD14	RD13	RD12	RD11	RD10	00000000 <sub>B</sub>	R/W

Controls the pull-up resistor in input mode.

0 : Without pull-up resistor in input mode.

1 : With pull-up resistor in input mode.

Meaningless in output mode. (Without pull-up resistor)/The input/output mode is decided by the setting of the port direction register (DDR).

Without pull-up resistor is used in stop mode (SPL = 1). (High-Z) This function is disabled when the external bus is used. Do not attempt to write to this register.

• Register list (Output pin register)

ODR4	7	6	5	4	3	2	1	0	Initial Value	Access
Address : 00001B <sub>H</sub>	OD47	OD46	OD45	OD44	OD43	OD42	OD41	OD40	00000000 <sub>B</sub>	R/W

Controls open-drain in output mode.

0 : Serves as a standard output port in output mode.

1 : Serves as an open-drain output port in output mode.

Meaningless in input mode (output High-Z)./The input/output mode is decided by the setting of the port direction register (DDR). This function is disabled when the external bus is used. Do not attempt to write to this register.

- Block diagram of port 0 pin and port 1 pin

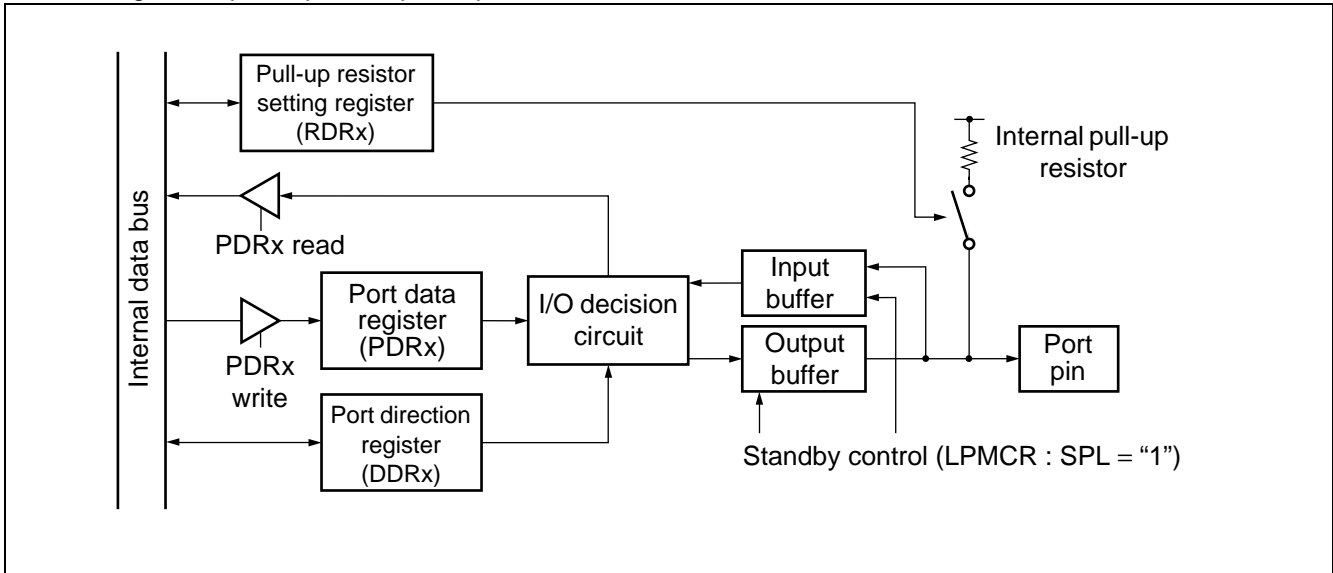

- Block diagram of port 2 pin, port 3 pin, port 4 pin, port 5 pin, port 6 pin, port 9 pin, port A pin and port B pin

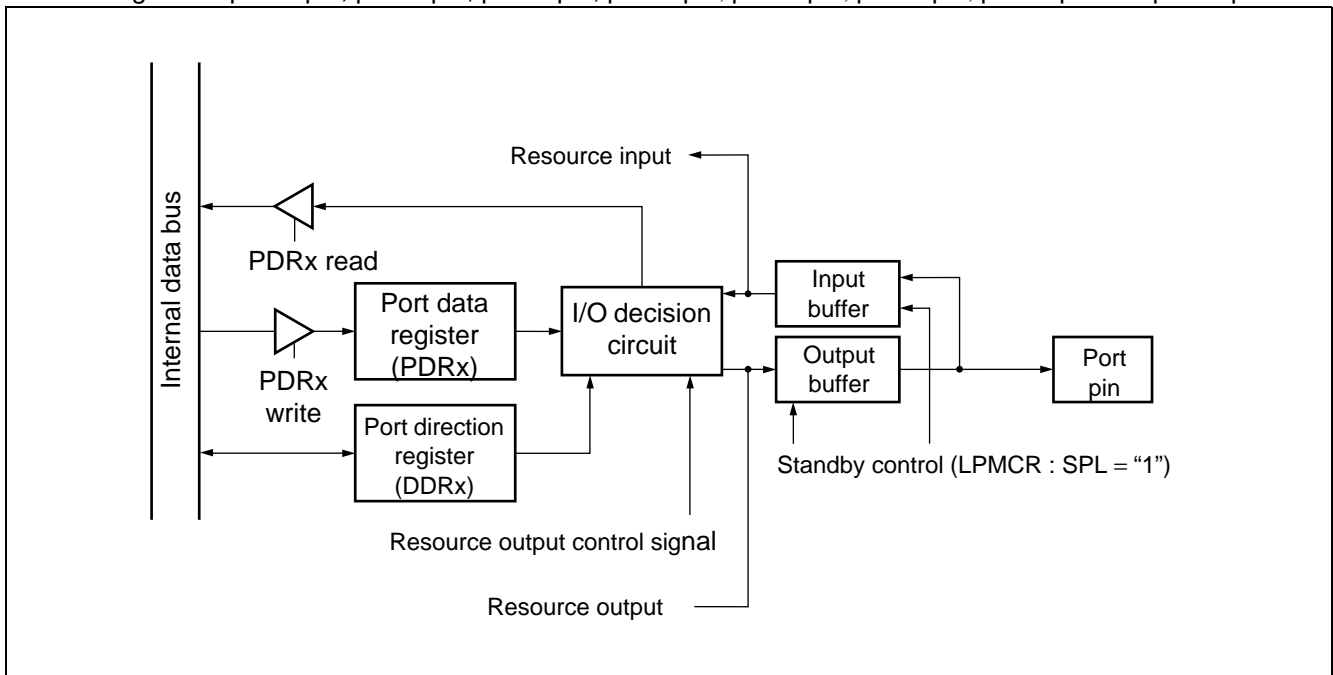

# MB90330 Series

- Block diagram of port 7 pin and port 8 pin

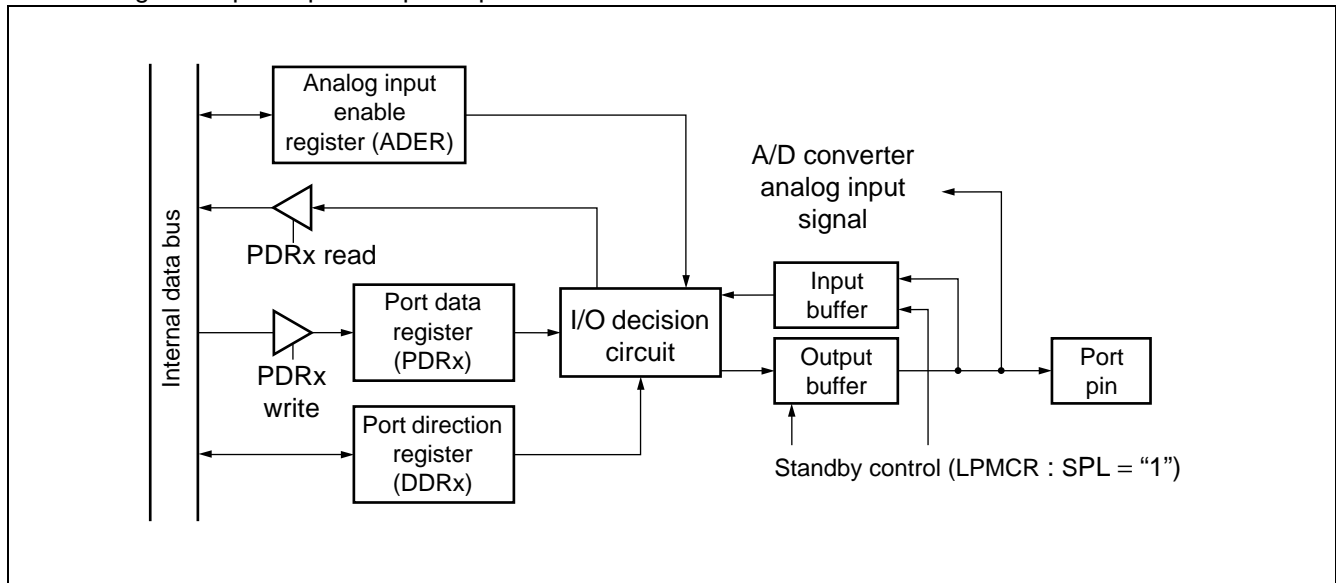

- Notes :
- When using as an input port, set " 0 " in the corresponding bit of the port-7 and port-8 direction register (DDR7 and DDR8) and " 0 " in the related bit of the analog input enable register (ADER).
  - When using as an analog input pin, set " 0 " in the corresponding bit of the port-7 and port-8 direction register (DDR7 and DDR8) and " 1 " in the related bit of the analog input enable register (ADER).

## 2. Time-base timer

The time-base timer is an 18-bit free-run counter (time-base timer counter) that counts in synchronization with the main clock (2 cycles of the oscillation clock HCLK). Four different time intervals can be selected, for each of which an interrupt request can be generated. Operating clock signals are supplied to peripheral resources such as the oscillation stabilization wait timer and watchdog timer.

- Interval time of time-base timer

Internal count clock cycle	Interval time
2/HCLK (0.33 μs)	2 <sup>12</sup> /HCLK (Approx. 0.68 ms)
	2 <sup>14</sup> /HCLK (Approx. 2.7 ms)
	2 <sup>16</sup> /HCLK (Approx. 10.9 ms)
	2 <sup>19</sup> /HCLK (Approx. 87.4 ms)

Notes : • HCLK : Oscillation clock frequency  
 • The parenthesized values assume an oscillator clock frequency of 6 MHz.

- Clock cycles supplied from time-base timer

Where to supply clock	Clock cycle
Main clock oscillation stabilization wait	2 <sup>13</sup> /HCLK (Approx. 1.36 ms)
	2 <sup>15</sup> /HCLK (Approx. 5.46 ms)
	2 <sup>17</sup> /HCLK (Approx. 21.84 ms)
Watch dog timer	2 <sup>12</sup> /HCLK (Approx. 0.68 ms)
	2 <sup>14</sup> /HCLK (Approx. 2.7 ms)
	2 <sup>16</sup> /HCLK (Approx. 10.9 ms)
	2 <sup>19</sup> /HCLK (Approx. 87.4 ms)

Notes : • HCLK : Oscillation clock frequency  
 • The parenthesized values assume an oscillator clock frequency of 6 MHz.

- Register list

Time-base timer control register (TBTC)								Initial Value	
Address : 0000A9 <sub>H</sub>	15	14	13	12	11	10	9	8	1 - - 00100 <sub>B</sub>
	RESV	—	—	TBIE	TBOF	TBR	TBC1	TBC0	
	(R/W)	(—)	(—)	(R/W)	(R/W)	(W)	(R/W)	(R/W)	

# MB90330 Series

## • Block Diagram

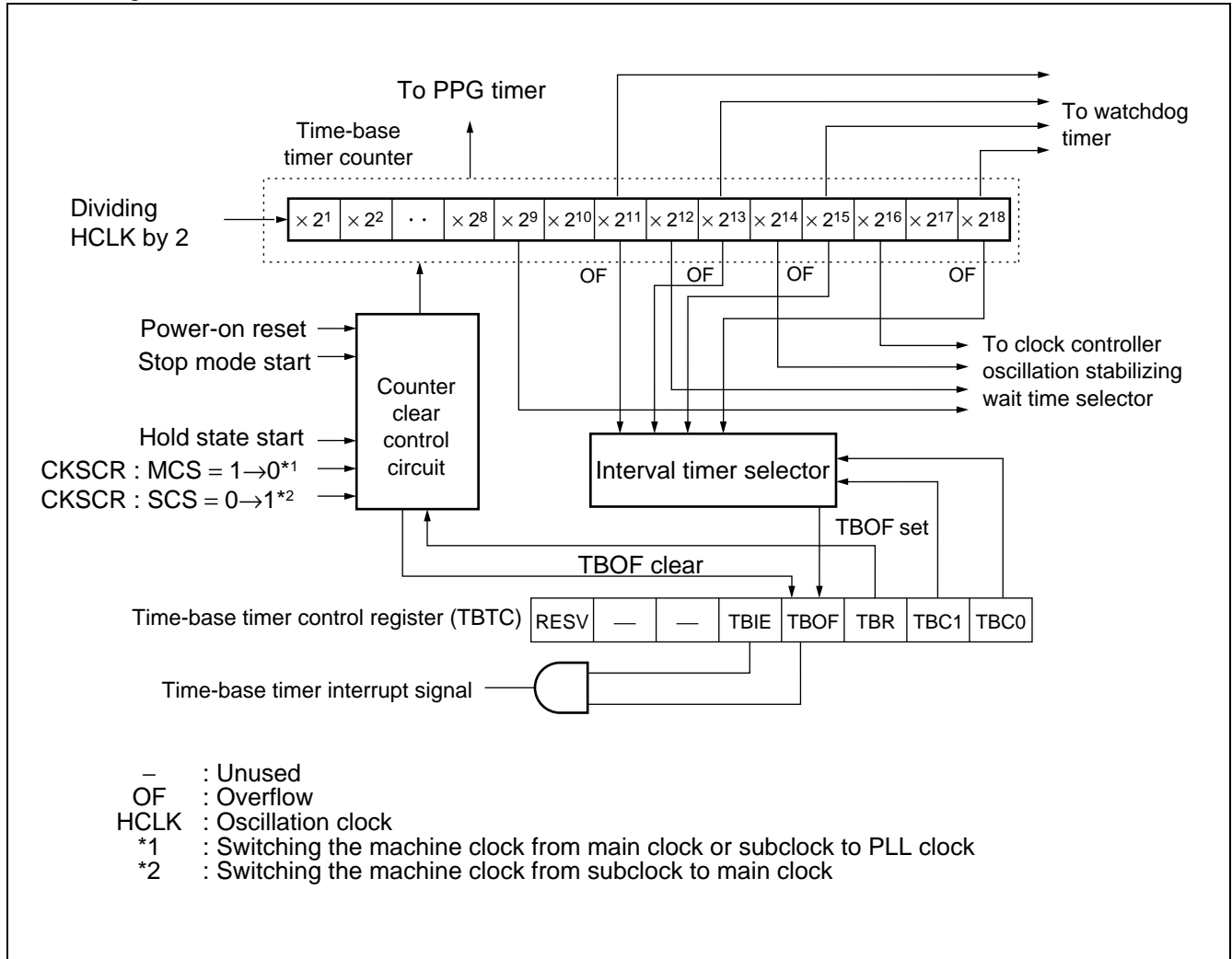

Actual interrupt request number of time-base timer is as follows :  
 Interrupt request number : #40 (28H)



### 3. Watchdog timer

The watchdog timer is timer counter provided for measure of program runaway. It is a 2-bit counter operating with an output of the timebase timer or watch timer as the count clock and resets the CPU when the counter is not cleared for a preset period of time after start.

- Interval time of watchdog timer

HCLK : Oscillation clock(6 MHz) SCLK : Sub clock(8 KHz)		
Min	Max	Clock cycle
Approx. 2.39 ms	Approx. 3.07 ms	$2^{14} \pm 2^{11}/\text{HCLK}$
Approx. 9.56 ms	Approx. 12.29 ms	$2^{16} \pm 2^{13}/\text{HCLK}$
Approx. 38.23 ms	Approx. 49.15 ms	$2^{18} \pm 2^{15}/\text{HCLK}$
Approx. 305.83 ms	Approx. 393.22 ms	$2^{21} \pm 2^{18}/\text{HCLK}$
Approx. 0.448 s	Approx. 0.576 s	$2^{12} \pm 2^9/\text{SCLK}$
Approx. 3.584 s	Approx. 4.608 s	$2^{15} \pm 2^{12}/\text{SCLK}$
Approx. 7.168 s	Approx. 9.216 s	$2^{16} \pm 2^{13}/\text{SCLK}$
Approx. 14.336 s	Approx. 18.432 s	$2^{17} \pm 2^{14}/\text{SCLK}$

- Notes :
- The maximum and minimum time intervals for the watchdog timer depend on the counter clear timing.
  - The watchdog timer contains a 2-bit counter that counts the carry-up signal from the time-base timer or watch timer.
  - Interval time of watchdog timer is longer than the set time during the following conditions.
    - When clearing the timebase timer during operation on oscillation (HCLK)
    - When clearing the watch timer during operation on sub clock (SCLK)

- Events that stop the watchdog timer

- Stop due to a power-on reset
- Watchdog reset

- Clear factor of watchdog timer

- External reset input by  $\overline{\text{RST}}$  pin
- Writing "0" to the software reset bit
- Writing "0" to the watchdog timer control bit (second and subsequent times)
- Transition to sleep mode (clearing the watchdog timer to suspend counting)
- Transition to time-base timer mode (clearing the watchdog timer to suspend counting)
- Transition to stop mode (clearing the watchdog timer to suspend counting)

# MB90330 Series

## • Register list

Watchdog timer control register (WDTC)								Initial Value	
Address : 0000A8H	7	6	5	4	3	2	1	0	X-XXX111B
	PONR	—	WRST	ERST	SRST	WTE	WT1	WT0	
	(R)	(—)	(R)	(R)	(R)	(W)	(W)	(W)	

## • Block Diagram

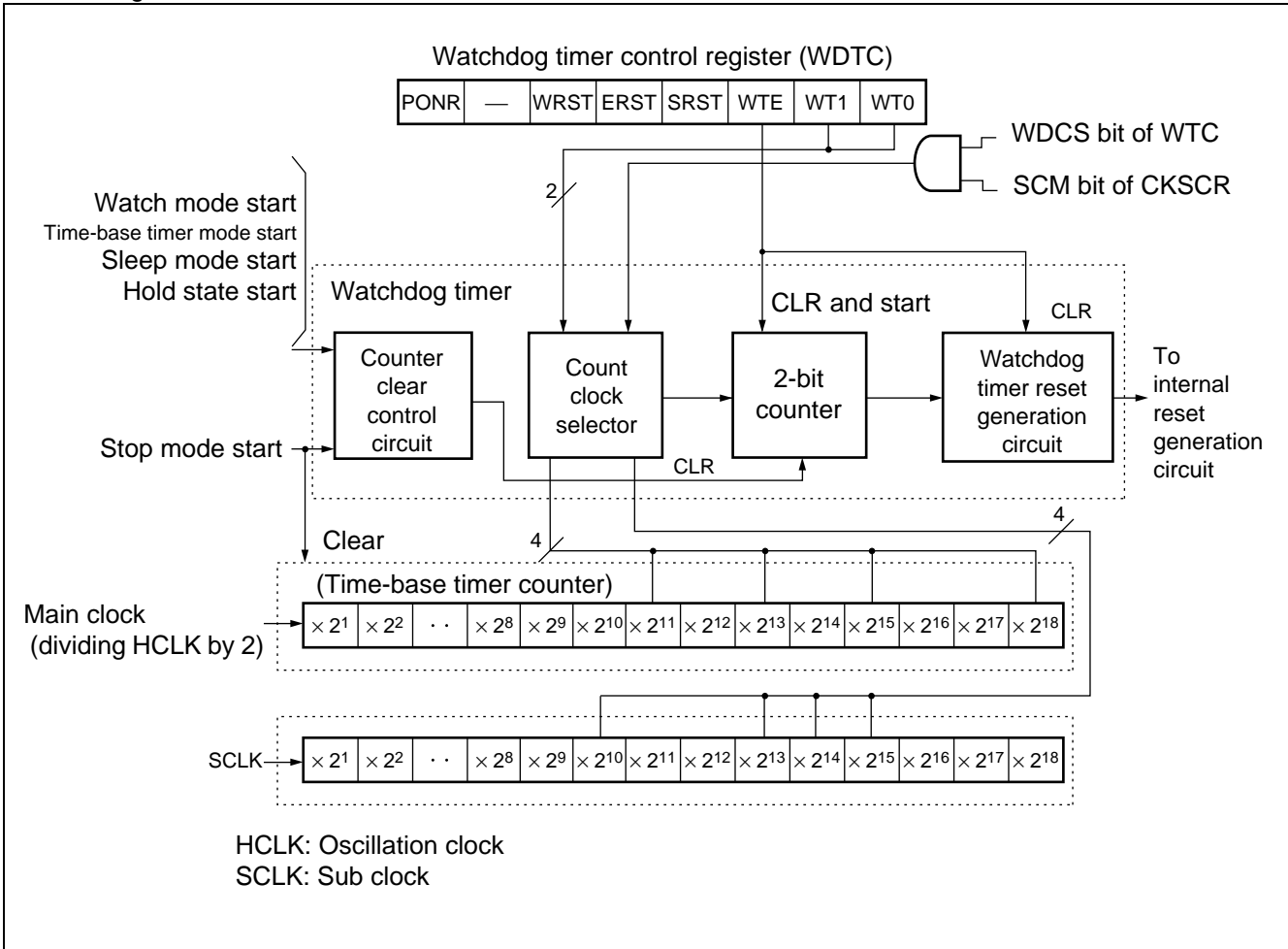

## 4. Watch timer

The watch timer is a 15-bit timer using the subclock. It can generate interval interrupts. It can also be used as a clock source for the watchdog timer.

### • Register list

Watch timer control register (WTC)								Initial Value	
Address : 0000AA <sub>H</sub>	7	6	5	4	3	2	1	0	10001000 <sub>B</sub>
	WDCS	SCE	WTIE	WTOF	WTR	WTC2	WTC1	WTC0	
	(R/W)	(R)	(R/W)	(R/W)	(R/W)	(R/W)	(R/W)	(R/W)	

### • Block Diagram

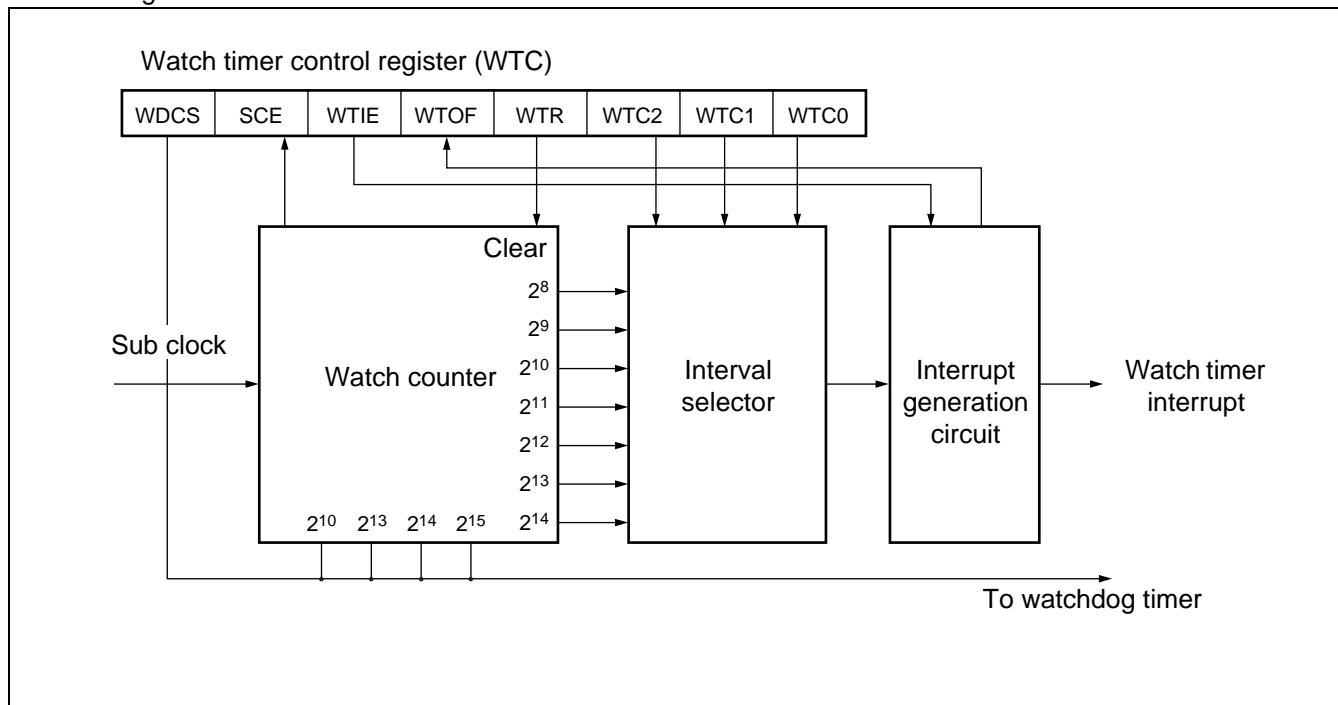

# MB90330 Series

## 5. 16-bit reload timer

The 16-bit reload timer has the internal clock mode to decrement in synchronization with 3 different internal clocks and the event count mode to decrement upon detection of an arbitrary edge of the pulse input to the external pin. Either can be selected. This timer defines when the count value changes from 0000H to FFFFH as an underflow. The timer therefore causes an underflow when the count reaches [reload register setting + 1]. Either mode can be selected for the count operation from the reload mode which repeats the count by reloading the count setting value at the underflow occurrence or the one-shot mode which stops the count at the underflow occurrence. The interrupt can be generated at the counter underflow occurrence so as to correspond to the DTC.

### • Register list

#### • TMCSR (Timer control status register 0 to 2)

Timer control status register (upper) (TMCSR0 to TMCSR2)

Address : 000063H	15	14	13	12	11	10	9	8	Initial Value XXXX0000 <sub>B</sub>
000067H	—	—	—	—	CSL1	CSL0	MOD2	MOD1	
00006BH	(—)	(—)	(—)	(—)	(R/W)	(R/W)	(R/W)	(R/W)	

Timer control status register (lower) (TMCSR0 to TMCSR2)

Address : 000062H	7	6	5	4	3	2	1	0	Initial Value 00000000 <sub>B</sub>
000066H	MOD0	OUTE	OUTL	RELD	INTE	UF	CNTE	TRG	
00006AH	(R/W)	(R/W)	(R/W)	(R/W)	(R/W)	(R/W)	(R/W)	(R/W)	

#### • 16-bit timer register/16-bit reload register

TMR0 to TMR2/TMRLR0 to TMRLR2 (upper)

Address : 000065H	15	14	13	12	11	10	9	8	Initial Value XXXXXXXX <sub>B</sub>
000069H	D15	D14	D13	D12	D11	D10	D09	D08	
00006DH	(R/W)	(R/W)	(R/W)	(R/W)	(R/W)	(R/W)	(R/W)	(R/W)	

TMR0 to TMR2/TMRLR0 to TMRLR2 (lower)

Address : 000064H	7	6	5	4	3	2	1	0	Initial Value XXXXXXXX <sub>B</sub>
000068H	D07	D06	D05	D04	D03	D02	D01	D00	
00006CH	(R/W)	(R/W)	(R/W)	(R/W)	(R/W)	(R/W)	(R/W)	(R/W)	

• Block diagram

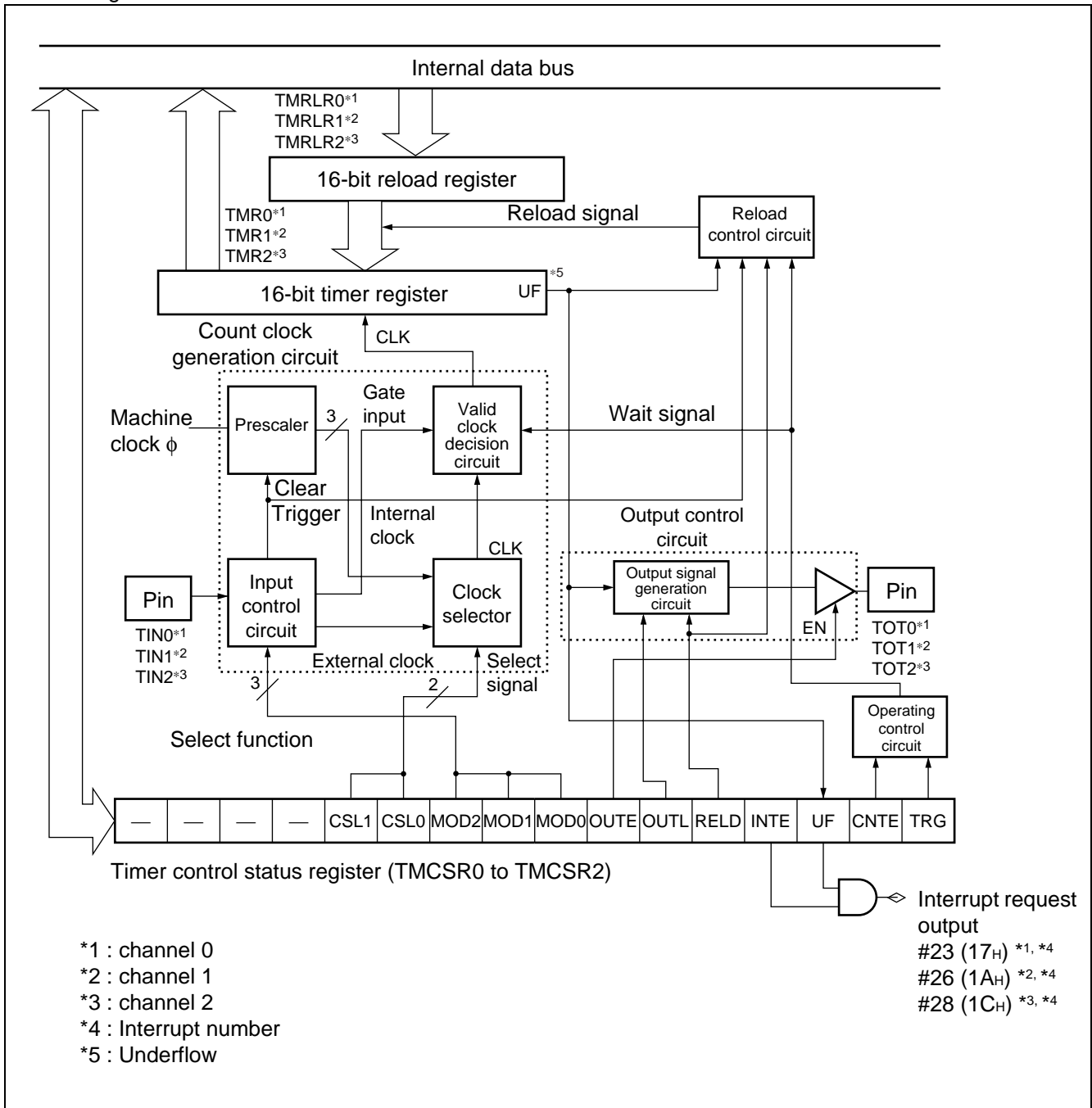

# MB90330 Series

## 6. Multi function timer

The multi-function timer enables the following based on the 16-bit free-run timer.

- Output of independent waveform
- Measurement of input pulse width
- Measurement of external clock cycle

### • Configuration of a multi-functional timer

16-bit free-run timer	16-bit Output Compare	16-bit Input Capture	8/16-bit PPG timer	16-bit PWC timer
1 channel	4 channels	4 channels	8-bit × 6 channels (16-bit × 3 channels)	1 channel

### • 16-bit free-run timer : 1 channel

The 16-bit free-run timer consists of a 16-bit up counter (timer data register (TCDT)), compare clear register (CPCLR), timer control status register (TCCS), and prescaler.

The counter output value of the 16-bit free-run timer is used as the base timer for the output compare and input capture units.

- The count clock can be set, selected from among the following eight types.  
1/φ, 2/φ, 4/φ, 8/φ, 16/φ, 32/φ, 64/φ, 128/φ  
φ : Machine clock frequency
- During the following conditions, the interrupt should be output.
  - The counter value of 16-bit free run timer will be overflowed.
  - The counter value of 16-bit free run timer will be cleared after the counter value of 16-bit free run timer = the compare clear register value (CPCLR) (TCCS : ICRE = "1", MODE = "1")
- The counter value of 16-bit free run timer should be cleared to "0000H" during the following conditions.
  - Reset
  - When setting the clear bit (SCLR) of timer control status register (TCCS) to "1"
  - When the counter value of the 16-bit free run timer = the compare clear register value (CPCLR) (TCCS : MODE = "1")
  - When setting "0000H" to the timer data register (TCDT)

### • Output compare : 4 channels

The output compare unit consists of compare registers (OCCP0 to OCCP3), compare control registers (OCS0 to OCS3), and a compare output latch.

The output compare unit can invert the output level and output an interrupt when a compare register (OCCP0 to OCCP3) value matches the counter value of the 16-bit free-run timer.

- Output compare registers can operate as 4 independent channels. The compare registers (OCCP0 to OCCP3) of each channel have interrupt request flags of their respective output pins.
- Pin output can be inverted by using 2 channels of compare registers (OCCP0 to OCCP3).
- If the counter value of 16-bit free run timer = the compare register (OCCP0 to OCCP3) (OCS0, OCS2 : IOP0 = "1", IOP1 = "1"), the interrupt request should be generated.
- The initial value for pin output of each channel can be set.

### • Input capture : 4 channels

The input capture unit consists of the input capture data registers (IPCP0 to IPCP3) corresponding to external input pins (IN0 to IN3) and input capture control registers (ICS01, ICS23).

The input capture unit can capture the counter value of the 16-bit free-run timer into the input capture data register (IPCP0 to IPCP3) to generated an interrupt request upon detection of the effective edge of the signal input through the external input.

- The input capture unit in each channel can operate independently.
- The effective edge of the external signal can be selected (rising edge, falling edge, both edges).
- An interrupt request can be generated upon detection of the selected effective edge of the external signal.(ICS01, ICS2 : ICE0 = "1", ICE1 = "1", ICE2 = "1", ICE3 = "1").

• Register list (16-bit free-run timer)

Compare clear register (CPCLR)								Initial Value	
Address : 00008B <sub>H</sub>	15	14	13	12	11	10	9	8	XXXXXXXX <sub>B</sub>
	CL15	CL14	CL13	CL12	CL11	CL10	CL09	CL08	
	(R/W)	(R/W)	(R/W)	(R/W)	(R/W)	(R/W)	(R/W)	(R/W)	
Timer data register (TCDT)								Initial Value	
Address : 00008A <sub>H</sub>	7	6	5	4	3	2	1	0	XXXXXXXX <sub>B</sub>
	CL07	CL06	CL05	CL04	CL03	CL02	CL01	CL00	
	(R/W)	(R/W)	(R/W)	(R/W)	(R/W)	(R/W)	(R/W)	(R/W)	
Timer data register (TCDT)								Initial Value	
Address : 000087 <sub>H</sub>	15	14	13	12	11	10	9	8	00000000 <sub>B</sub>
	T15	T14	T13	T12	T11	T10	T09	T08	
	(R/W)	(R/W)	(R/W)	(R/W)	(R/W)	(R/W)	(R/W)	(R/W)	
Timer data register (TCDT)								Initial Value	
Address : 000086 <sub>H</sub>	7	6	5	4	3	2	1	0	00000000 <sub>B</sub>
	T07	T06	T05	T04	T03	T02	T01	T00	
	(R/W)	(R/W)	(R/W)	(R/W)	(R/W)	(R/W)	(R/W)	(R/W)	
Timer control/status register (TCCS)								Initial Value	
Address : 000089 <sub>H</sub>	15	14	13	12	11	10	9	8	0--00000 <sub>B</sub>
	ECKE	—	—	MSI2	MSI1	MSI0	ICLR	ICRE	
	(R/W)	(R/W)	(R/W)	(R/W)	(R/W)	(R/W)	(R/W)	(R/W)	
Timer control/status register (TCCS)								Initial Value	
Address : 000088 <sub>H</sub>	7	6	5	4	3	2	1	0	00000000 <sub>B</sub>
	IVF	IVFE	STOP	MODE	SCLR	CLK2	CLK1	CLK0	
	(R/W)	(R/W)	(R/W)	(R/W)	(R/W)	(R/W)	(R/W)	(R/W)	

# MB90330 Series

• Register list (output compare)

Compare register (OCCP0 to OCCP3)

Address : 007919H	15	14	13	12	11	10	9	8	Initial Value
00791BH	C15	C14	C13	C12	C11	C10	C09	C08	XXXXXXXX <sub>B</sub>
00791DH	(R/W)	(R/W)	(R/W)	(R/W)	(R/W)	(R/W)	(R/W)	(R/W)	
00791FH	(R/W)	(R/W)	(R/W)	(R/W)	(R/W)	(R/W)	(R/W)	(R/W)	

Address : 007918H	7	6	5	4	3	2	1	0	Initial Value
00791AH	C07	C06	C05	C04	C03	C02	C01	C00	XXXXXXXX <sub>B</sub>
00791CH	(R/W)	(R/W)	(R/W)	(R/W)	(R/W)	(R/W)	(R/W)	(R/W)	
00791EH	(R/W)	(R/W)	(R/W)	(R/W)	(R/W)	(R/W)	(R/W)	(R/W)	

Control register (OCS1/OCS3)

Address : 000055H	15	14	13	12	11	10	9	8	Initial Value
000057H	—	—	—	CMOD	OTE1	OTE0	OTD1	OTD0	---0000 <sub>B</sub>
	(—)	(—)	(—)	(R/W)	(R/W)	(R/W)	(R/W)	(R/W)	

Control register (OCS0/OCS2)

Address : 000054H	7	6	5	4	3	2	1	0	Initial Value
000056H	ICP1	ICP0	ICE1	ICE0	—	—	CST1	CST0	0000--00 <sub>B</sub>
	(R/W)	(R/W)	(R/W)	(R/W)	(—)	(—)	(R/W)	(R/W)	



• Register list (input capture)

Input capture data register (IPCP0 to IPCP3)

Address : 007911H	15	14	13	12	11	10	9	8	Initial Value XXXXXXXX <sub>B</sub>
007913H	CP15	CP14	CP13	CP12	CP11	CP10	CP09	CP08	
007915H	(R)	(R)	(R)	(R)	(R)	(R)	(R)	(R)	
007917H	(R)	(R)	(R)	(R)	(R)	(R)	(R)	(R)	

Address : 007910H	7	6	5	4	3	2	1	0	Initial Value XXXXXXXX <sub>B</sub>
007912H	CP07	CP06	CP05	CP04	CP03	CP02	CP01	CP00	
007914H	(R)	(R)	(R)	(R)	(R)	(R)	(R)	(R)	
007916H	(R)	(R)	(R)	(R)	(R)	(R)	(R)	(R)	

Input capture control status register (ICS23)

Address : 000053H	15	14	13	12	11	10	9	8	Initial Value 00000000 <sub>B</sub>
	ICP3	ICP2	ICE3	ICE2	EG31	EG30	EG21	EG20	
	(R/W)	(R/W)	(R/W)	(R/W)	(R/W)	(R/W)	(R/W)	(R/W)	

Input capture control status register (ICS01)

Address : 000052H	7	6	5	4	3	2	1	0	Initial Value 00000000 <sub>B</sub>
	ICP1	ICP0	ICE1	ICE0	EG11	EG10	EG01	EG00	
	(R/W)	(R/W)	(R/W)	(R/W)	(R/W)	(R/W)	(R/W)	(R/W)	

# MB90330 Series

- Block diagram of the 16-bit free-run timer, input capture units, and output compare units

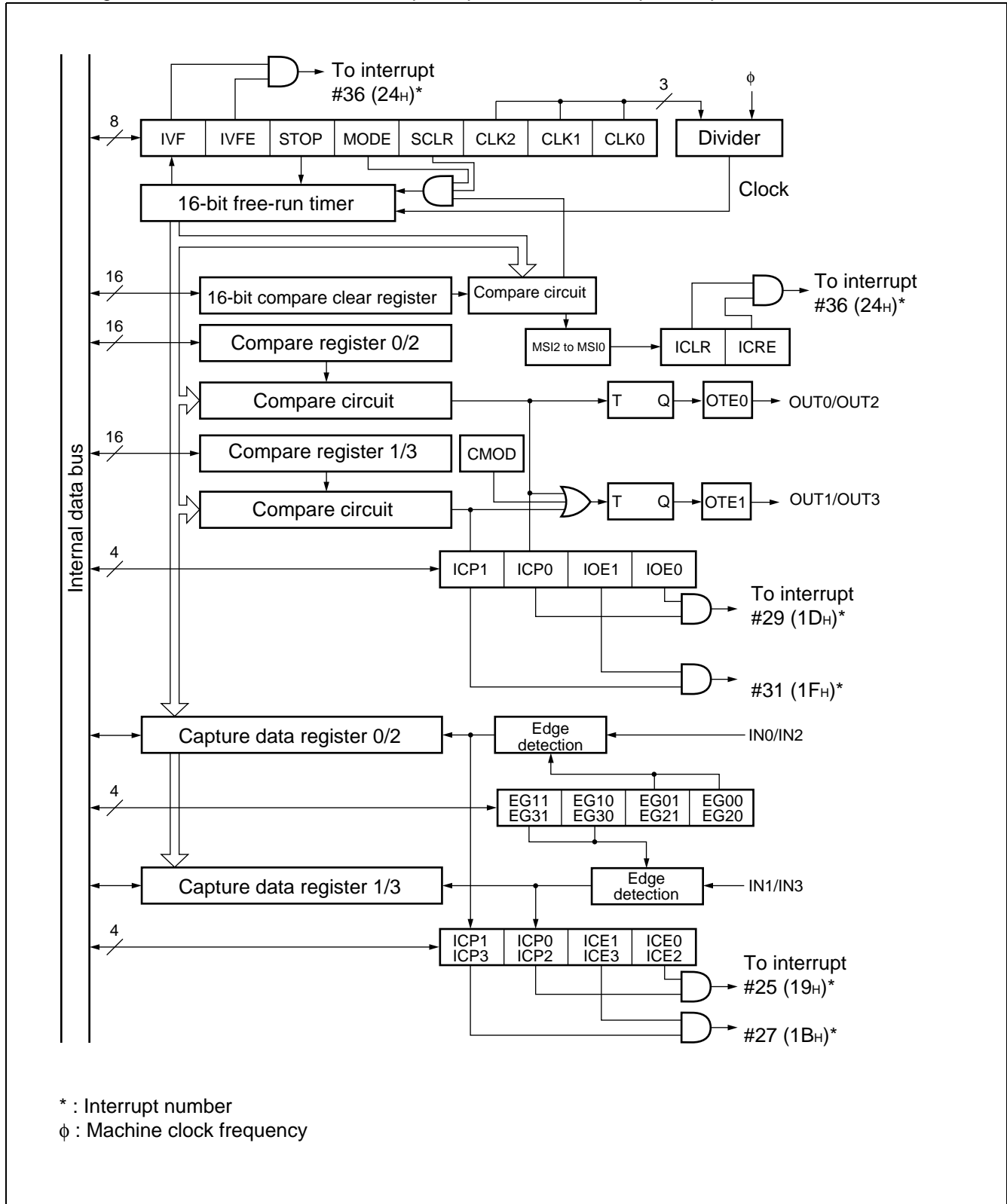

- 8/16-bit PPG timer (8-bit : 6 channels, 16-bit : 3 channels)

8/16-bit PPG timer consists of an 8-bit down counter (PCNT), PPG control register (PPGC0 to PPGC5), PPG output control register (PPG01, PPG23, PPG45) and PPG reload register (PRL0 to PRL5, PRLH0 to PRLH5). When used as an 8-/16-bit reload timer, the PPG timer serves as an event timer. It can also output pulses of an arbitrary duty ratio at an arbitrary frequency.

- 8-bit PPG mode

Each channel operates as an independent 8-bit PPG.

- 8-bit prescaler + 8-bit PPG mode

Operates as an arbitrary-cycle 8-bit PPG with PPG0 (PPG2, PPG4) operating as an 8-bit prescaler and PPG1 (PPG3, PPG5) counted by the borrow output of PPG0 (PPG2, PPG4).

- 16-bit PPG mode

Operates as a 16-bit PPG with PPG0 (PPG2, PPG4) and PPG1 (PPG3, PPG5) connected.

- PPG operation

The PPG timer outputs pulses of an arbitrary duty ratio (the ratio between the High and Low level periods of pulse waveform) at an arbitrary frequency. This can also be used as a D/A converter by an external circuit.

# MB90330 Series

• Register list

PPG operation mode control register  
(PPGC1/PPGC3/PPGC5)

Address : 000047H	15	14	13	12	11	10	9	8	Initial Value 0X000001 <sub>B</sub>
000049H	PEN1	—	PE10	PIE1	PUF1	MD1	MD0	Reserved	
00004BH	(R/W)	(—)	(R/W)	(R/W)	(R/W)	(R/W)	(R/W)	(R/W)	

(PPGC0/PPGC2/PPGC4)

Address : 000046H	7	6	5	4	3	2	1	0	Initial Value 0X000XX1 <sub>B</sub>
000048H	PEN0	—	PE00	PIE0	PUF0	—	—	Reserved	
00004AH	(R/W)	(—)	(R/W)	(R/W)	(R/W)	(—)	(—)	(R/W)	

PPG output control register (PPG01/PPG23/PPG45)

Address : 00004CH	7	6	5	4	3	2	1	0	Initial Value 000000XX <sub>B</sub>
00004EH	PCS2	PCS1	PCS0	PCM2	PCM1	PCM0	Reserved	Reserved	
000050H	(R/W)	(R/W)	(R/W)	(R/W)	(R/W)	(R/W)	(R/W)	(R/W)	

PPG reload register  
(PRLH0 to PRLH5)

Address : 007901H	15	14	13	12	11	10	9	8	Initial Value XXXXXXXX <sub>B</sub>
007903H	D15	D14	D13	D12	D11	D10	D09	D08	
007905H	(R/W)	(R/W)	(R/W)	(R/W)	(R/W)	(R/W)	(R/W)	(R/W)	
007907H	(R/W)	(R/W)	(R/W)	(R/W)	(R/W)	(R/W)	(R/W)	(R/W)	
007909H	(R/W)	(R/W)	(R/W)	(R/W)	(R/W)	(R/W)	(R/W)	(R/W)	
00790BH	(R/W)	(R/W)	(R/W)	(R/W)	(R/W)	(R/W)	(R/W)	(R/W)	

(PRL0 to PRL5)

Address : 007900H	7	6	5	4	3	2	1	0	Initial Value XXXXXXXX <sub>B</sub>
007902H	D07	D06	D05	D04	D03	D02	D01	D00	
007904H	(R/W)	(R/W)	(R/W)	(R/W)	(R/W)	(R/W)	(R/W)	(R/W)	
007906H	(R/W)	(R/W)	(R/W)	(R/W)	(R/W)	(R/W)	(R/W)	(R/W)	
007908H	(R/W)	(R/W)	(R/W)	(R/W)	(R/W)	(R/W)	(R/W)	(R/W)	
00790AH	(R/W)	(R/W)	(R/W)	(R/W)	(R/W)	(R/W)	(R/W)	(R/W)	

• 8/16-bit PPG ch0/2/4 block diagram

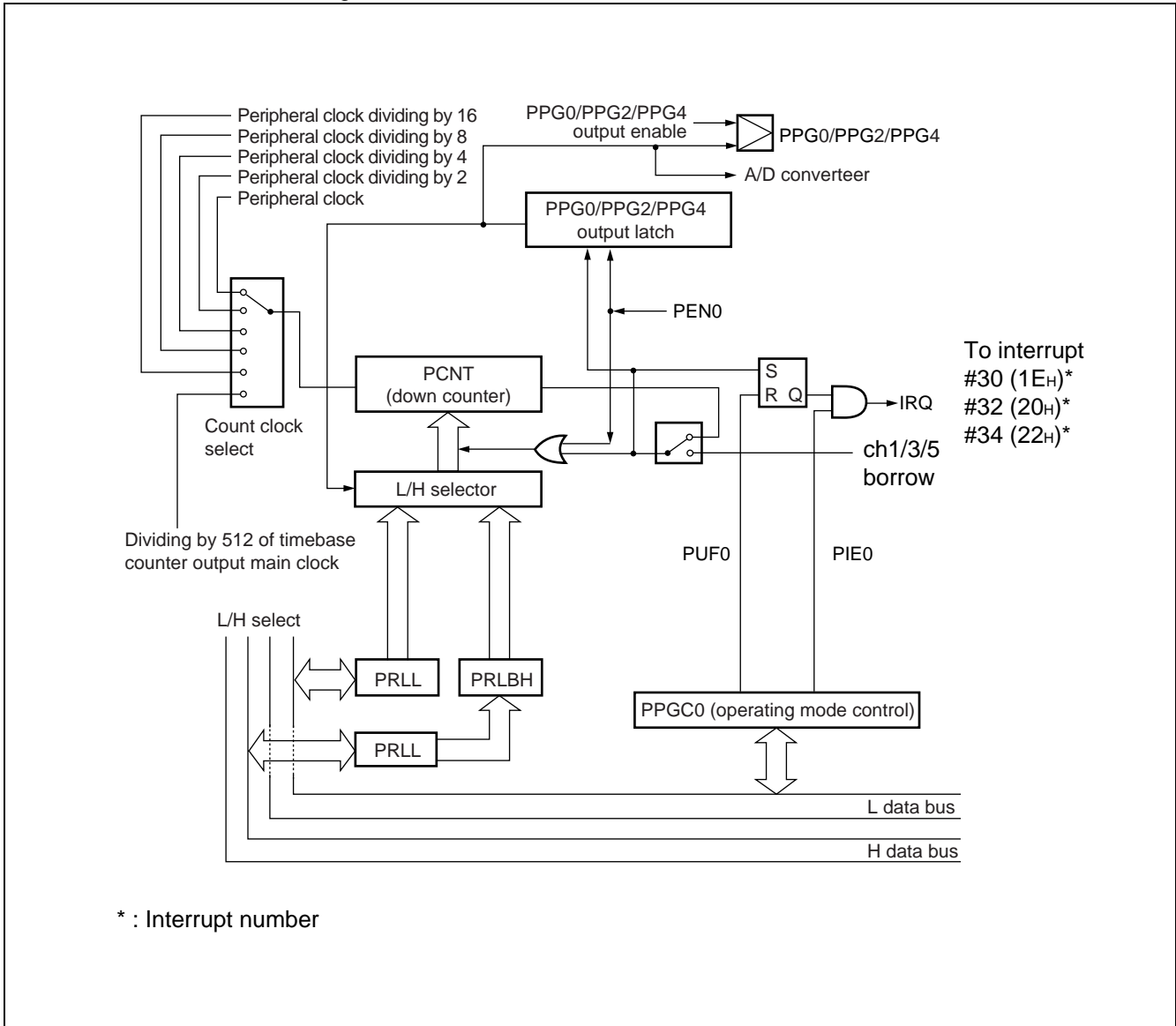

# MB90330 Series

## • 8-bit PPG ch1/3/5 block diagram

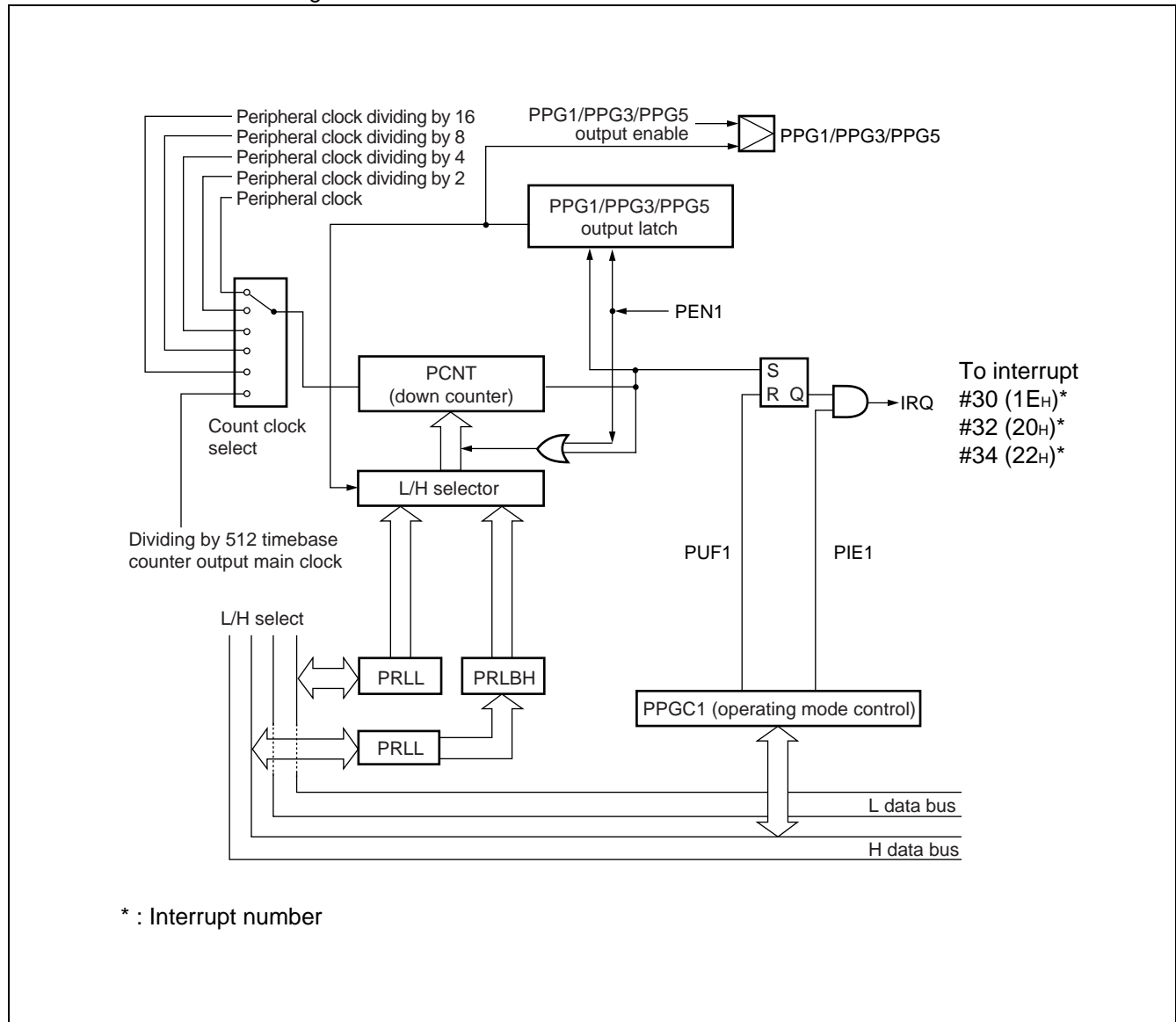

- PWC timer

The PWC timer is a 16-bit multi-function up-count timer capable of measuring the input signal pulse width.

- Register list

PWC control status register (PWCSR)								Initial Value	
Address : 00005D <sub>H</sub>	15	14	13	12	11	10	9	8	0000000X <sub>B</sub>
	STRT	STOP	EDIR	EDIE	OVIR	OVIE	ERR	Reserved	
	(R/W)	(R/W)	(R)	(R/W)	(R/W)	(R/W)	(R)	(R/W)	
PWC data buffer register (PWCR)								Initial Value	
Address : 00005C <sub>H</sub>	7	6	5	4	3	2	1	0	00000000 <sub>B</sub>
	CKS1	CKS0	PIS1	PIS0	S/C	MOD2	MOD1	MOD0	
	(R/W)	(R/W)	(R/W)	(R/W)	(R/W)	(R/W)	(R/W)	(R/W)	
PWC data buffer register (PWCR)								Initial Value	
Address : 00005F <sub>H</sub>	15	14	13	12	11	10	9	8	00000000 <sub>B</sub>
	D15	D14	D13	D12	D11	D10	D9	D8	
	(R/W)	(R/W)	(R/W)	(R/W)	(R/W)	(R/W)	(R/W)	(R/W)	
PWC data buffer register (PWCR)								Initial Value	
Address : 00005E <sub>H</sub>	7	6	5	4	3	2	1	0	00000000 <sub>B</sub>
	D7	D6	D5	D4	D3	D2	D1	D0	
	(R/W)	(R/W)	(R/W)	(R/W)	(R/W)	(R/W)	(R/W)	(R/W)	
Ratio of dividing frequency control register (DIVR)								Initial Value	
Address : 000060 <sub>H</sub>	7	6	5	4	3	2	1	0	-----00 <sub>B</sub>
	—	—	—	—	—	—	DIV1	DIV0	
	(—)	(—)	(—)	(—)	(—)	(—)	(R/W)	(R/W)	

# MB90330 Series

## • Block Diagram

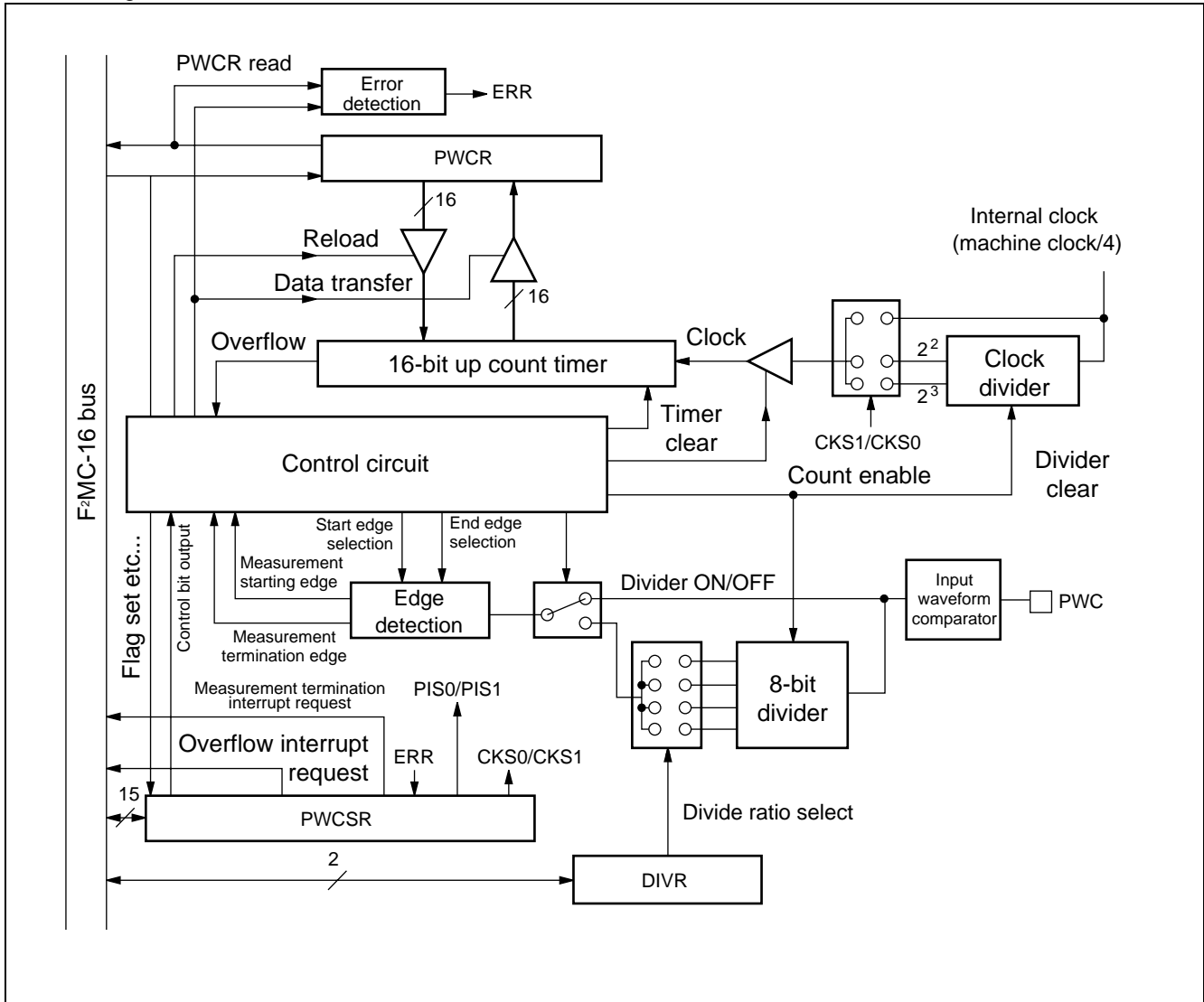



## 7. UART

UART is a general purpose serial communication interface for synchronous or asynchronous (start-stop synchronization) communications with external devices. It supports bi-directional communication (normal mode) and master/slave communication (multi-processor mode: supported on master side only). An interrupt can be generated upon completion of reception, detection of a reception error, or completion of transmission. EI<sup>2</sup>OS is supported.

### • UART functions

UART, or a generic serial data communication interface that sends and receives serial data to and from other CPU and peripherals, has the functions listed in following.

	Function
Data buffer	Full-duplex double-buffered
Transmission mode	<ul style="list-style-type: none"> <li>• Clock synchronous (without start/stop bit)</li> <li>• Clock asynchronous (start-stop synchronous)</li> </ul>
Baud rate	<ul style="list-style-type: none"> <li>• Special-purpose baud-rate generator It is optional from 8 kinds.</li> <li>• Baud rate by external clock (SCK0/SCK1/SCK2/SCK3 terminal input)</li> </ul>
Data length	<ul style="list-style-type: none"> <li>• 8-bit or 7-bit (in the asynchronous normal mode only)</li> <li>• 1-bit to 8-bit (synchronous mode only)</li> </ul>
Signal system	Non Return to Zero (NRZ) system
Reception error detection	<ul style="list-style-type: none"> <li>• Framing error</li> <li>• Overrun error</li> <li>• Parity error (Not supported in operation mode 1)</li> </ul>
Interrupt request	<ul style="list-style-type: none"> <li>• Receive interrupt (reception completed, reception error detected)</li> <li>• Transmission interrupt (transmission completed)</li> <li>• Both the transmission and reception support EI<sup>2</sup>OS.</li> </ul>
Master/slave type communication function (multi processor mode)	Capable of 1 (master) to many (slaves) communication (available just as master)

Note : In clock synchronous transfer mode, the UART transfers only data with no start or stop bit added.

### • UART operation modes

Operation mode		Data length		Synchronization	Stop bit length
		Without parity	With parity		
0	Normal mode	7-bit or 8-bit		Asynchronous	1-bit or 2-bit *2
1	Multi processor mode	8-bit + 1*1	—	Asynchronous	
2	Normal mode	1 to 8-bit	—	Synchronous	No

— : Setting disabled

\*1 : + 1 is an address/data setting bit (A/D) which is used for communication control.

\*2 : Only one bit can be detected as a stop bit at reception.

# MB90330 Series

## • Register list

### Serial mode register (SMR0 to SMR3)

		7	6	5	4	3	2	1	0	Initial Value
Address :	000020H	MD1	MD0	SCKL	M2L2	M2L1	M2L0	SCKE	SOE	00100000 <sub>B</sub>
	000026H	(R/W)	(R/W)	(R/W)	(R/W)	(R/W)	(R/W)	(R/W)	(R/W)	
	00002CH									
	000032H									

### Serial control register (SCR0 to SCR3)

		15	14	13	12	11	10	9	8	Initial Value
Address :	000021H	PEN	P	SBL	CL	A/D	REC	RXE	TXE	00000100 <sub>B</sub>
	000027H	(R/W)	(R/W)	(R/W)	(R/W)	(R/W)	(W)	(R/W)	(R/W)	
	00002DH									
	000033H									

### Serial input/output data register (SIDR0 to SIDR3 / SODR0 to SODR3)

		7	6	5	4	3	2	1	0	Initial Value
Address :	000022H	D7	D6	D5	D4	D3	D2	D1	D0	XXXXXXXX <sub>B</sub>
	000028H	(R/W)	(R/W)	(R/W)	(R/W)	(R/W)	(R/W)	(R/W)	(R/W)	
	00002EH									
	000034H									

### Serial status register (SSR0 to SSR3)

		15	14	13	12	11	10	9	8	Initial Value
Address :	000023H	PE	ORE	FRE	RDRF	TDRE	BDS	RIE	TIE	00001000 <sub>B</sub>
	000029H	(R)	(R)	(R)	(R)	(R)	(R/W)	(R/W)	(R/W)	
	00002FH									
	000035H									

### UART prescaler reload register (UTRLR0 to UTRLR3)

		7	6	5	4	3	2	1	0	Initial Value
Address :	000024H	D7	D6	D5	D4	D3	D2	D1	D0	00000000 <sub>B</sub>
	00002AH	(R/W)	(R/W)	(R/W)	(R/W)	(R/W)	(R/W)	(R/W)	(R/W)	
	000030H									
	000036H									

### UART prescaler control register (UTCR0 to UTCR3)

		15	14	13	12	11	10	9	8	Initial Value
Address :	000025H	MD	SRST	CKS	Reserved	—	D10	D9	D8	0000-000 <sub>B</sub>
	00002BH	(R/W)	(R/W)	(R/W)	(R/W)	(—)	(R/W)	(R/W)	(R/W)	
	000031H									
	000037H									

• Block Diagram

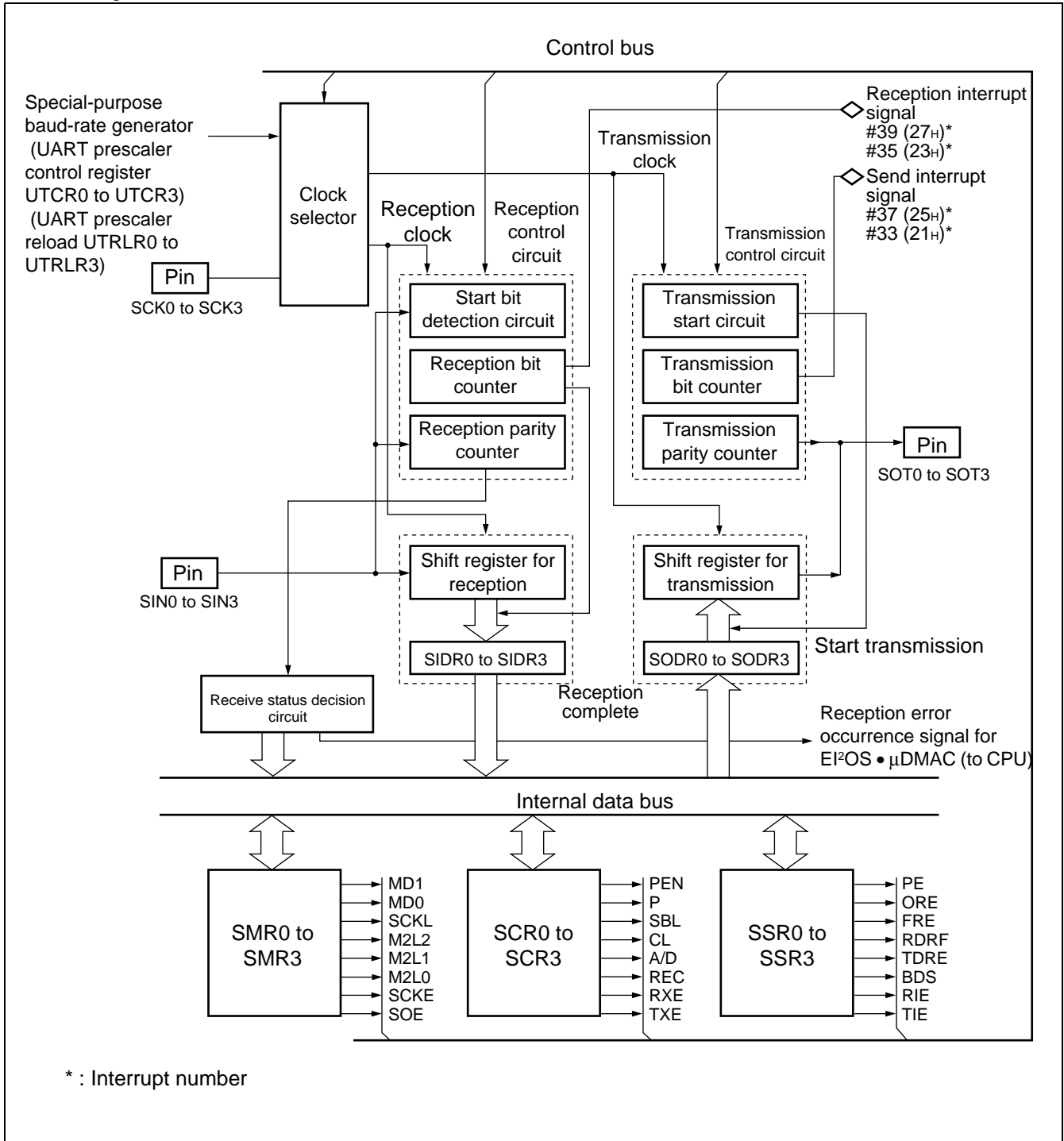

# MB90330 Series

## 8. Extended I/O serial interface

The extended I/O serial interface is a serial I/O interface in an 8-bit, single-channel, capable of clock synchronous data transfer. LSB-first or MSB-first transfer mode can be selected for data transfer.

There are 2 serial I/O operation modes available:

- Internal shift clock mode: Transfer data in synchronization with the internal clock.
- External shift clock mode: Transfer data in synchronization with the clock supplied via the external pin (SCK).  
By manipulating the general-purpose port sharing the external pin (SCK) in this mode, data can also be transferred by a CPU instruction.

### • Register list

Serial mode control status register (SMCS)								Initial Value	
Address : 000059 <sub>H</sub>	15	14	13	12	11	10	9	8	00000010 <sub>B</sub>
	SMD2	SMD1	SMD0	SIE	SIR	BUSY	STOP	STRT	
	(R/W)	(R/W)	(R/W)	(R/W)	(R/W)	(R/W)	(R/W)	(R/W)	
Serial mode control status register (SMCS)								Initial Value	
Address : 000058 <sub>H</sub>	7	6	5	4	3	2	1	0	XXXX0000 <sub>B</sub>
	—	—	—	—	MODE	BDS	SOE	SCOE	
	(—)	(—)	(—)	(—)	(R/W)	(R/W)	(R/W)	(R/W)	
Serial data register (SDR)								Initial Value	
Address : 00005A <sub>H</sub>	7	6	5	4	3	2	1	0	XXXXXXXX <sub>B</sub>
	D7	D6	D5	D4	D3	D2	D1	D0	
	(R/W)	(R/W)	(R/W)	(R/W)	(R/W)	(R/W)	(R/W)	(R/W)	
Communication prescaler control register (SDCR)								Initial Value	
Address : 00005B <sub>H</sub>	15	14	13	12	11	10	9	8	0XXX0000 <sub>B</sub>
	MD	—	—	—	DIV3	DIV2	DIV1	DIV0	
	(R/W)	(—)	(—)	(—)	(R/W)	(R/W)	(R/W)	(R/W)	

• Block Diagram

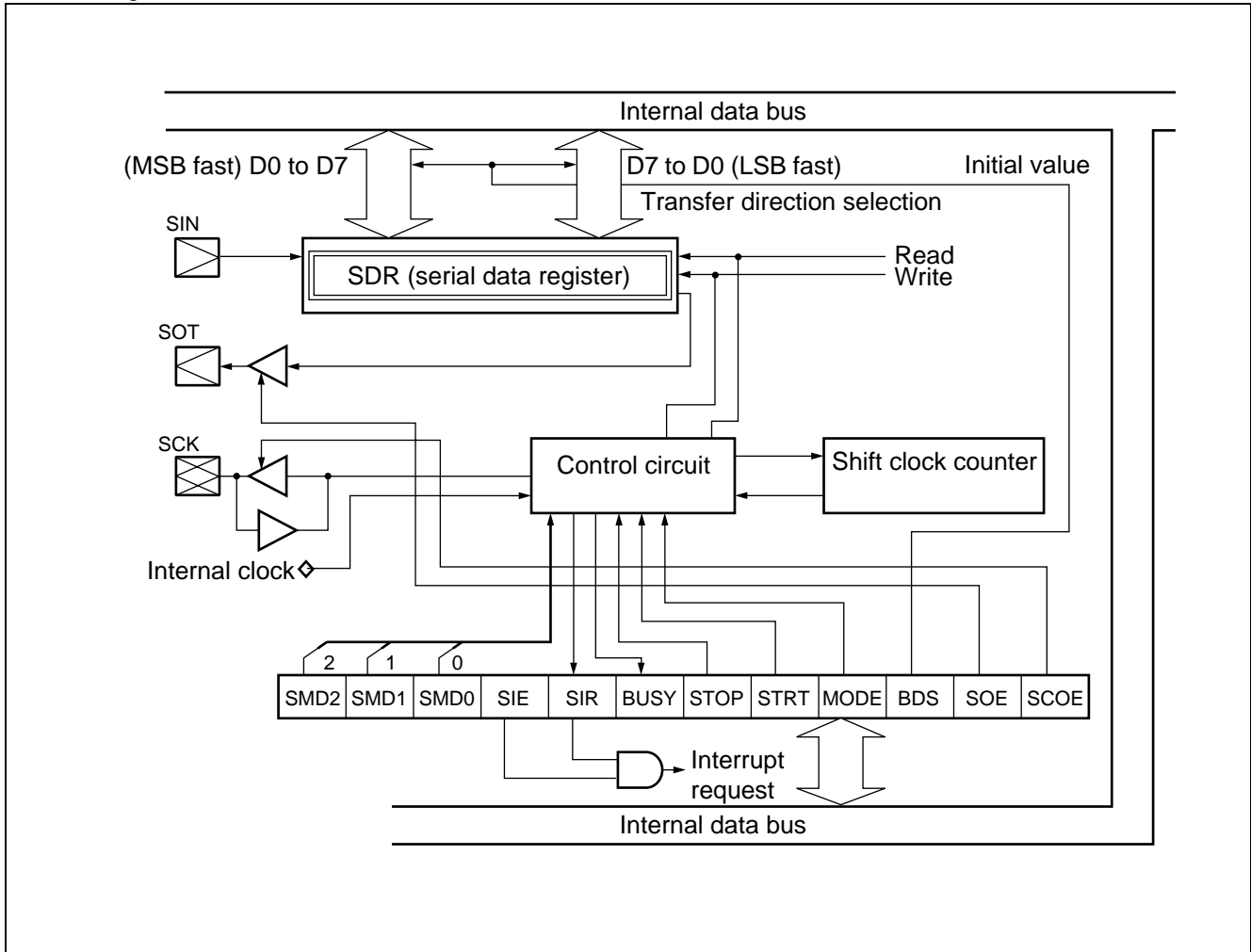

# MB90330 Series

## 9. I<sup>2</sup>C Interface

The I<sup>2</sup>C interface is a serial I/O port supporting the Inter IC BUS. It serves as a master/slave device on the I<sup>2</sup>C bus and has the following features.

- Master/slave sending and receiving
- Arbitration function
- Clock synchronization function
- Slave address and general call address detection function
- Detecting transmitting direction function
- Start condition repeated generation and detection function
- Bus error detection function

### • Register list

#### I<sup>2</sup>C bus status register (IBSR0 to IBSR2)

Address : 000070 <sub>H</sub>	7	6	5	4	3	2	1	0	Initial Value 00000000 <sub>B</sub>
000076 <sub>H</sub>	BB	RSC	AL	LRB	TRX	AAS	GCA	FBT	
00007C <sub>H</sub>	(R)	(R)	(R)	(R)	(R)	(R)	(R)	(R)	

#### I<sup>2</sup>C bus control register (IBCR0 to IBCR2)

Address : 000071 <sub>H</sub>	15	14	13	12	11	10	9	8	Initial Value 00000000 <sub>B</sub>
000077 <sub>H</sub>	BER	BEIE	SCC	MSS	ACK	GCAA	INTE	INT	
00007D <sub>H</sub>	(R/W)	(R/W)	(R/W)	(R/W)	(R/W)	(R/W)	(R/W)	(R/W)	

#### I<sup>2</sup>C bus clock selection register (ICCR0 to ICCR2)

Address : 000072 <sub>H</sub>	7	6	5	4	3	2	1	0	Initial Value XX0XXXXX <sub>B</sub>
000078 <sub>H</sub>	—	—	EN	CS4	CS3	CS2	CS1	CS0	
00007E <sub>H</sub>	(—)	(—)	(R/W)	(R/W)	(R/W)	(R/W)	(R/W)	(R/W)	

#### I<sup>2</sup>C bus address register (IADR0 to IADR2)

Address : 000073 <sub>H</sub>	15	14	13	12	11	10	9	8	Initial Value XXXXXXXX <sub>B</sub>
000079 <sub>H</sub>	—	A6	A5	A4	A3	A2	A1	A0	
00007F <sub>H</sub>	(—)	(R/W)	(R/W)	(R/W)	(R/W)	(R/W)	(R/W)	(R/W)	

#### I<sup>2</sup>C bus data register (IDAR0 to IDAR2)

Address : 000074 <sub>H</sub>	7	6	5	4	3	2	1	0	Initial Value XXXXXXXX <sub>B</sub>
00007A <sub>H</sub>	D7	D6	D5	D4	D3	D2	D1	D0	
000080 <sub>H</sub>	(R/W)	(R/W)	(R/W)	(R/W)	(R/W)	(R/W)	(R/W)	(R/W)	

• Block Diagram

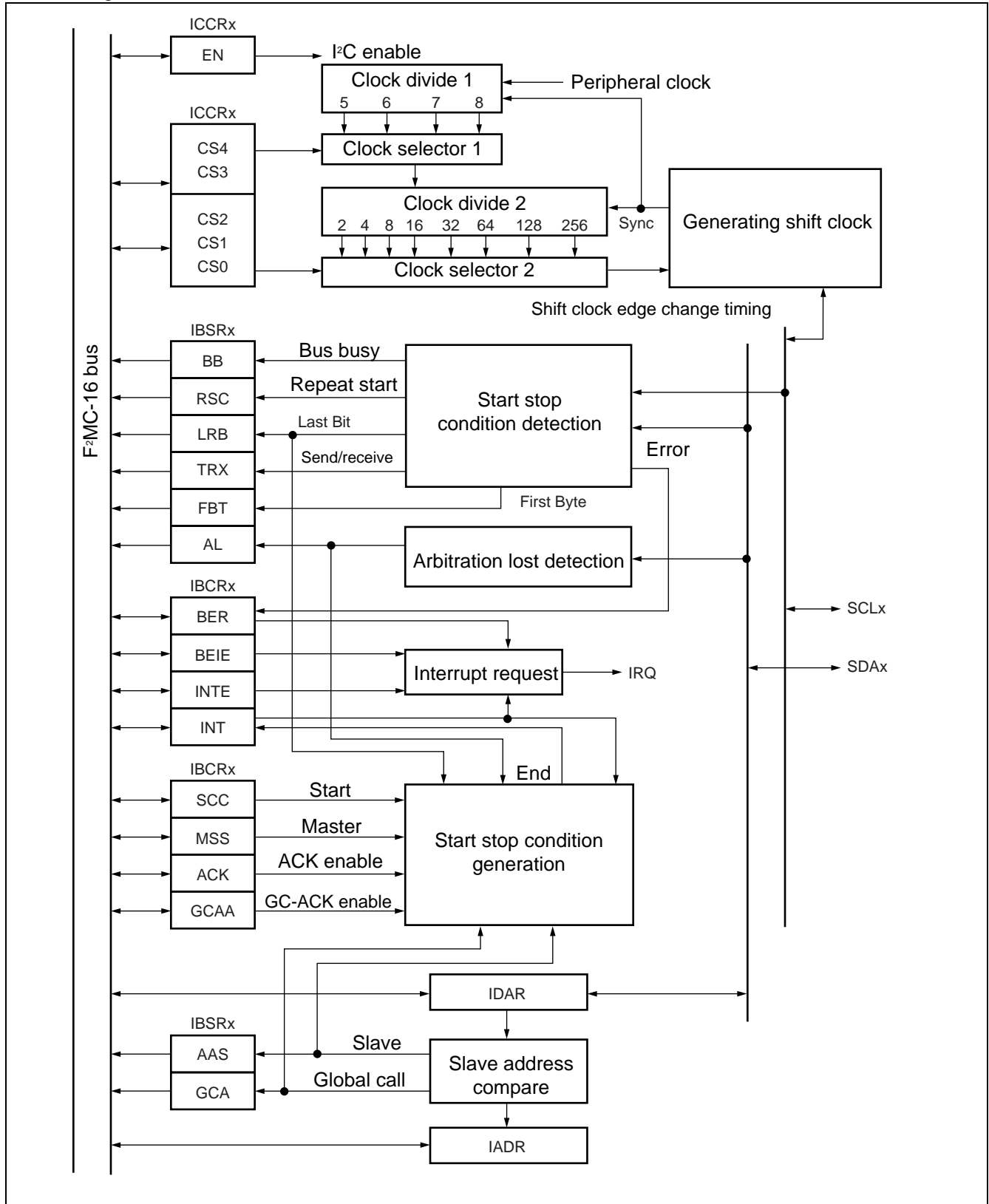

# MB90330 Series

## 10. USB Function

The USB function is an interface supporting the USB (Universal Serial Bus) communications protocol.

- Feature of USB function
  - Conform to USB2.0 Full Speed
  - Full speed (12 Mbps) is supported.
  - The device status is auto-answer.
  - Bit stripping, bit stuffing, and automatic generation and check of CRC5 and CRC16
  - Toggle check by data synchronization bit
  - Automatic response to all standard commands except Get/SetDescriptor and SynchFrame commands (these 3 commands can be processed the same way as the class vendor commands).
  - The class vendor commands can be received as data and responded via firmware.
  - Supports up to 6 EndPoints (EndPoint0 is fixed to control transfer)
  - 2 transfer data buffers integrated for each end point (one IN buffer and one OUT buffer for EndPoint 0)
  - Supports automatic transfer mode for transfer data via DMA (except buffers for EndPoint 0)
  - Capable of detection of connection and disconnection by monitoring the USB bus power line
- Register list

UDC control register (UDCC)								Initial Value	
Address : 0000D0H	7	6	5	4	3	2	1	0	10100000 <sub>B</sub>
	RST	RESUM	HCON	USTP	Reserved	Reserved	RFBK	PWC	
	(R/W)	(R/W)	(R/W)	(R/W)	(R/W)	(R/W)	(R/W)	(R/W)	
EP0 control register (EP0C)								Initial Value	
Address : 0000D2H	7	6	5	4	3	2	1	0	X1000000 <sub>B</sub>
	Reserved	PKS0	PKS0	PKS0	PKS0	PKS0	PKS0	PKS0	
	(R/W)	(R/W)	(R/W)	(R/W)	(R/W)	(R/W)	(R/W)	(R/W)	
Address : 0000D3H	15	14	13	12	11	10	9	8	Initial Value XXXX000X <sub>B</sub>
	—	—	—	—	Reserved	Reserved	STAL	Reserved	
	(—)	(—)	(—)	(—)	(R/W)	(R/W)	(R/W)	(R/W)	
EP1 control register (EP1C)								Initial Value	
Address : 0000D4H	7	6	5	4	3	2	1	0	00000000 <sub>B</sub>
	PKS1	PKS1	PKS1	PKS1	PKS1	PKS1	PKS1	PKS1	
	(R/W)	(R/W)	(R/W)	(R/W)	(R/W)	(R/W)	(R/W)	(R/W)	
Address : 0000D5H	15	14	13	12	11	10	9	8	Initial Value 01100001 <sub>B</sub>
	EPEN	TYPE	TYPE	DIR	DMAE	NULE	STAL	PKS1	
	(R/W)	(R/W)	(R/W)	(R/W)	(R/W)	(R/W)	(R/W)	(R/W)	

(Continued)



## EP2/3/4/5 control register (EP2C to EP5C)

Address : 0000D6 <sub>H</sub>	7	6	5	4	3	2	1	0	Initial Value
0000D8 <sub>H</sub>	Reserved	PKS2 to 5	PKS2 to 5	PKS2 to 5	PKS2 to 5	PKS2 to 5	PKS2 to 5	PKS2 to 5	0100000 <sub>B</sub>
0000DA <sub>H</sub>	(R/W)	(R/W)	(R/W)	(R/W)	(R/W)	(R/W)	(R/W)	(R/W)	
0000DC <sub>H</sub>									

Address : 0000D7 <sub>H</sub>	15	14	13	12	11	10	9	8	Initial Value
0000D9 <sub>H</sub>	EPEN	TYPE	TYPE	DIR	DMAE	NULE	STAL	Reserved	0110000 <sub>B</sub>
0000DB <sub>H</sub>	(R/W)	(R/W)	(R/W)	(R/W)	(R/W)	(R/W)	(R/W)	(R/W)	
0000DD <sub>H</sub>									

## Time stamp register (TMSP)

Address : 0000DE <sub>H</sub>	7	6	5	4	3	2	1	0	Initial Value
	TMSP	TMSP	TMSP	TMSP	TMSP	TMSP	TMSP	TMSP	0000000 <sub>B</sub>
	(R)	(R)	(R)	(R)	(R)	(R)	(R)	(R)	

Address : 0000DF <sub>H</sub>	15	14	13	12	11	10	9	8	Initial Value
	—	—	—	—	—	TMSP	TMSP	TMSP	0000000 <sub>B</sub>
	(—)	(—)	(—)	(—)	(—)	(R)	(R)	(R)	

## UDC status register (UDCS)

Address : 0000E0 <sub>H</sub>	7	6	5	4	3	2	1	0	Initial Value
	VOFF	VON	SUSP	SOF	BRST	WKUP	SETP	CONF	0000000 <sub>B</sub>
	(R/W)	(R/W)	(R/W)	(R/W)	(R/W)	(R/W)	(R/W)	(R/W)	

## UDC Interrupt enable register (UDCIE)

Address : 0000E1 <sub>H</sub>	15	14	13	12	11	10	9	8	Initial Value
	VOFFIE	VONIE	SUSPIE	SOFIE	BRSTIE	WKUPIE	CONFN	CONFIE	0000000 <sub>B</sub>
	(R/W)	(R/W)	(R/W)	(R/W)	(R/W)	(R/W)	(R)	(R/W)	

## EP0I status register (EP0IS)

Address : 0000E2 <sub>H</sub>	7	6	5	4	3	2	1	0	Initial Value
	—	—	—	—	—	—	—	—	XXXXXXXX <sub>B</sub>
	(—)	(—)	(—)	(—)	(—)	(—)	(—)	(—)	

Address : 0000E3 <sub>H</sub>	15	14	13	12	11	10	9	8	Initial Value
	BFINI	DRQIE	—	—	—	DRQI	—	—	10XXX1XX <sub>B</sub>
	(R/W)	(R/W)	(—)	(—)	(—)	(R/W)	(—)	(—)	

(Continued)

# MB90330 Series

(Continued)

## EP00 status register (EP00S)

Address : 0000E4H	7	6	5	4	3	2	1	0	Initial Value XXXXXXXX <sub>B</sub>
	—	SIZE	SIZE	SIZE	SIZE	SIZE	SIZE	SIZE	
	(—)	(R)	(R)	(R)	(R)	(R)	(R)	(R)	

Address : 0000E5H	15	14	13	12	11	10	9	8	Initial Value 100XX00X <sub>B</sub>
	BFINI	DRQOIE	SPKIE	—	—	DRQO	SPK	—	
	(R/W)	(R/W)	(R/W)	(—)	(—)	(R/W)	(R/W)	(—)	

## EP1 status register (EP1S)

Address : 0000E6H	7	6	5	4	3	2	1	0	Initial Value XXXXXXXX <sub>B</sub>
	SIZE	SIZE	SIZE	SIZE	SIZE	SIZE	SIZE	SIZE	
	(R/W)	(R/W)	(R/W)	(R/W)	(R/W)	(R/W)	(R/W)	(R/W)	

Address : 0000E7H	15	14	13	12	11	10	9	8	Initial Value 1000000X <sub>B</sub>
	BFINI	DRQIE	SPKIE	—	BUSY	DRQ	SPK	SIZE	
	(R/W)	(R/W)	(R/W)	(—)	(R)	(R/W)	(R/W)	(R/W)	

## EP2/3/4/5 status register (EP2S to EP5S)

Address : 0000E8H 0000EAH 0000ECH 0000EEH	7	6	5	4	3	2	1	0	Initial Value XXXXXXXX <sub>B</sub>
	—	SIZE	SIZE	SIZE	SIZE	SIZE	SIZE	SIZE	
	(—)	(R/W)	(R/W)	(R/W)	(R/W)	(R/W)	(R/W)	(R/W)	

Address : 0000E9H 0000EBH 0000EDH 0000EFH	15	14	13	12	11	10	9	8	Initial Value 1000000X <sub>B</sub>
	BFINI	DRQIE	SPKIE	—	BUSY	DRQ	SPK	—	
	(R/W)	(R/W)	(R/W)	(—)	(R)	(R/W)	(R/W)	(—)	

## EP0/1/2/3/4/5 data register (EP0DT to EP5DT)

Address : 0000F0H 0000F2H 0000F4H 0000F6H 0000F8H 0000FAH	7	6	5	4	3	2	1	0	Initial Value XXXXXXXX <sub>B</sub>
	BFDT	BFDT	BFDT	BFDT	BFDT	BFDT	BFDT	BFDT	
	(R/W)	(R/W)	(R/W)	(R/W)	(R/W)	(R/W)	(R/W)	(R/W)	

Address : 0000F1H 0000F3H 0000F5H 0000F7H 0000F9H 0000FBH	15	14	13	12	11	10	9	8	Initial Value XXXXXXXX <sub>B</sub>
	BFDT	BFDT	BFDT	BFDT	BFDT	BFDT	BFDT	BFDT	
	(R/W)	(R/W)	(R/W)	(R/W)	(R/W)	(R/W)	(R/W)	(R/W)	

## 11. USB Mini-HOST

USB Mini-HOST provides minimal host operations required and is a function that enables data to be transferred to and from Device without PC intervention.

- Feature of USB Mini-HOST
  - Automatic detection of Low Speed/Full Speed transfer
  - Low Speed/Full Speed transfer support
  - Automatic detection of connection and cutting device
  - Reset sending function support to USB-bus
  - Support of IN/OUT/SETUP/SOF token
  - In-token handshake packet automatic transmission (excluding STALL)
  - Out-token handshake packet automatic detection
  - Supports a maximum packet length of 256 bytes.
  - Error (CRC error/toggle error/time-out) various supports
  - Wake-Up function support
- Differences between the USB HOST and USB Mini-HOST

		HOST	Mini-HOST
Hub support		○	×
Transfer	Bulk transfer	○	○
	Control transfer	○	○
	Interrupt transfer	○	○
	ISO transfer	○	×
Transfer speed	Low Speed	○	○
	Full Speed	○	○
PRE packet support		○	×
SOF packet support		○	○
Error	CRC error	○	○
	Toggle error	○	○
	Time-out	○	○
	Maximum packet < receive data	○	○
Detection of connection and cutting of device		○	○
Transfer speed detection		○	○

- : Supported  
 × : Not supported

# MB90330 Series

## • Register list

USB host control register 0 (HCNT0)								Initial Value	
Address : 0000C0 <sub>H</sub>	7	6	5	4	3	2	1	0	0000000 <sub>B</sub>
	RWKIRE	URIRE	CMPIRE	CNNIRE	DIRE	SOFIRE	URST	HOST	
	(R/W)	(R/W)	(R/W)	(R/W)	(R/W)	(R/W)	(R/W)	(R/W)	
USB host control register 1 (HCNT1)								Initial Value	
Address : 0000C1 <sub>H</sub>	15	14	13	12	11	10	9	8	0000001 <sub>B</sub>
	Reserved	Reserved	Reserved	Reserved	Reserved	SOFSTEP	CANCEL	RETRY	
	(R/W)	(R/W)	(R/W)	(R/W)	(R/W)	(R/W)	(R/W)	(R/W)	
USB host interruption register (HIRQ)								Initial Value	
Address : 0000C2 <sub>H</sub>	7	6	5	4	3	2	1	0	0000000 <sub>B</sub>
	TCAN	Reserved	RWKIRQ	URIRQ	CMPIRQ	CNNIRQ	DIRQ	SOFIRQ	
	(R/W)	(R/W)	(R/W)	(R/W)	(R/W)	(R/W)	(R/W)	(R/W)	
USB host error status register (HERR)								Initial Value	
Address : 0000C3 <sub>H</sub>	15	14	13	12	11	10	9	8	0000011 <sub>B</sub>
	LSTSOF	RERR	TOUT	CRC	TGERR	STUFF	HS	HS	
	(R/W)	(R/W)	(R/W)	(R/W)	(R/W)	(R/W)	(R/W)	(R/W)	
USB host state status register (HSTATE)								Initial Value	
Address : 0000C4 <sub>H</sub>	7	6	5	4	3	2	1	0	XX010010 <sub>B</sub>
	—	—	ALIVE	CLKSEL	SOFBUSY	SUSP	TMODE	CSTAT	
	(—)	(—)	(R/W)	(R/W)	(R/W)	(R/W)	(R)	(R)	
USB SOF interruption FRAME comparison register (HFCOMP)								Initial Value	
Address : 0000C5 <sub>H</sub>	15	14	13	12	11	10	9	8	0000000 <sub>B</sub>
	FRAME COMP	FRAME COMP	FRAME COMP	FRAME COMP	FRAME COMP	FRAME COMP	FRAME COMP	FRAME COMP	
	(R/W)	(R/W)	(R/W)	(R/W)	(R/W)	(R/W)	(R/W)	(R/W)	

(Continued)

(Continued)

## USB retry timer setting register 0/1/2 (HRTIMER)

Address : 0000C6 <sub>H</sub>	7	6	5	4	3	2	1	0	Initial Value 0000000 <sub>B</sub>
	RTIMER0	RTIMER0	RTIMER0	RTIMER0	RTIMER0	RTIMER0	RTIMER0	RTIMER0	
	(R/W)	(R/W)	(R/W)	(R/W)	(R/W)	(R/W)	(R/W)	(R/W)	

Address : 0000C7 <sub>H</sub>	15	14	13	12	11	10	9	8	Initial Value 0000000 <sub>B</sub>
	RTIMER1	RTIMER1	RTIMER1	RTIMER1	RTIMER1	RTIMER1	RTIMER1	RTIMER1	
	(R/W)	(R/W)	(R/W)	(R/W)	(R/W)	(R/W)	(R/W)	(R/W)	

Address : 0000C8 <sub>H</sub>	7	6	5	4	3	2	1	0	Initial Value XXXXXX00 <sub>B</sub>
	—	—	—	—	—	—	RTIMER2	RTIMER2	
	(—)	(—)	(—)	(—)	(—)	(—)	(R/W)	(R/W)	

## USB host address register (HADR)

Address : 0000C9 <sub>H</sub>	15	14	13	12	11	10	9	8	Initial Value X000000 <sub>B</sub>
	—	ADDRESS	ADDRESS	ADDRESS	ADDRESS	ADDRESS	ADDRESS	ADDRESS	
	(—)	(R/W)	(R/W)	(R/W)	(R/W)	(R/W)	(R/W)	(R/W)	

## USB EOF setting register 0/1 (HEOF)

Address : 0000CA <sub>H</sub>	7	6	5	4	3	2	1	0	Initial Value 0000000 <sub>B</sub>
	EOF0	EOF0	EOF0	EOF0	EOF0	EOF0	EOF0	EOF0	
	(R/W)	(R/W)	(R/W)	(R/W)	(R/W)	(R/W)	(R/W)	(R/W)	

Address : 0000CB <sub>H</sub>	15	14	13	12	11	10	9	8	Initial Value XX00000 <sub>B</sub>
	—	—	EOF1	EOF1	EOF1	EOF1	EOF1	EOF1	
	(—)	(—)	(R/W)	(R/W)	(R/W)	(R/W)	(R/W)	(R/W)	

## USB FRAME setting register (HFRAME)

Address : 0000CC <sub>H</sub>	7	6	5	4	3	2	1	0	Initial Value 0000000 <sub>B</sub>
	FRAME0	FRAME0	FRAME0	FRAME0	FRAME0	FRAME0	FRAME0	FRAME0	
	(R/W)	(R/W)	(R/W)	(R/W)	(R/W)	(R/W)	(R/W)	(R/W)	

Address : 0000CD <sub>H</sub>	15	14	13	12	11	10	9	8	Initial Value XXXXX000 <sub>B</sub>
	—	—	—	—	—	FRAME1	FRAME1	FRAME1	
	(—)	(—)	(—)	(—)	(—)	(R/W)	(R/W)	(R/W)	

## USB token end point register (HTOKEN)

Address : 0000CE <sub>H</sub>	7	6	5	4	3	2	1	0	Initial Value 0000000 <sub>B</sub>
	TGGL	TKNEN	TKNEN	TKNEN	ENDPT	ENDPT	ENDPT	ENDPT	
	(R/W)	(R/W)	(R/W)	(R/W)	(R/W)	(R/W)	(R/W)	(R/W)	

# MB90330 Series

## 12. 8/10-bit A/D converter

The A/D converter converts analog input voltages into digital values and has the following features.

- RC sequential compare conversion method with sample and hold circuit
- Selectable 8-bit resolution or 10-bit resolution
- Analog input program-selectable from among 16 channels

Single conversion mode : Convert 1 selected channel

Scan conversion mode : Continuous plural channels (maximum 16 channels can be programmed) are converted.

Continuous conversion mode : Repeatedly convert the specified channels.

Stop conversion mode: Convert 1 channel then suspend conversion to remain on standby until the next activation. (Simultaneous conversion start available.)

- An interrupt request to the CPU can be generated upon completion of A/D conversion. Suitable for continuous processing as this interrupt activates  $\mu$ DMA to transfer the data resulting from A/D conversion to memory.
- The activation source can be selected from among software, external trigger (falling edge), and timer (rising edge).

### • Register list

AD control status register lower/upper (ADCS0/ADCS1)								Initial Value	
Address : 000040 <sub>H</sub>	7	6	5	4	3	2	1	0	00 - - - - 0 <sub>B</sub>
	MD1	MD0	—	—	—	—	—	Reserved	
	(R/W)	(R/W)	(—)	(—)	(—)	(—)	(—)	(R/W)	
AD control status register upper (ADCS0/ADCS1)								Initial Value	
Address : 000041 <sub>H</sub>	15	14	13	12	11	10	9	8	00000000 <sub>B</sub>
	BUSY	INT	INTE	PAUS	STS1	STS0	STRT	Reserved	
	(R/W)	(R/W)	(R/W)	(R/W)	(R/W)	(R/W)	(W)	(R/W)	
AD data register lower/upper (ADCR0/ADCR1)								Initial Value	
Address : 000042 <sub>H</sub>	7	6	5	4	3	2	1	0	XXXXXXXX <sub>B</sub>
	D7	D6	D5	D4	D3	D2	D1	D0	
	(R)	(R)	(R)	(R)	(R)	(R)	(R)	(R)	
AD data register upper (ADCR0/ADCR1)								Initial Value	
Address : 000043 <sub>H</sub>	15	14	13	12	11	10	9	8	00101XXX <sub>B</sub>
	S10	ST1	ST0	CT1	CT0	—	D9	D8	
	(R/W)	(W)	(W)	(W)	(W)	(—)	(R)	(R)	
AD conversion channel selection register (ADMR)								Initial Value	
Address : 000045 <sub>H</sub>	15	14	13	12	11	10	9	8	00000000 <sub>B</sub>
	ANS3	ANS2	ANS1	ANS0	ANE3	ANE2	ANE1	ANE0	
	(R/W)	(R/W)	(R/W)	(R/W)	(R/W)	(R/W)	(R/W)	(R/W)	

• Block Diagram

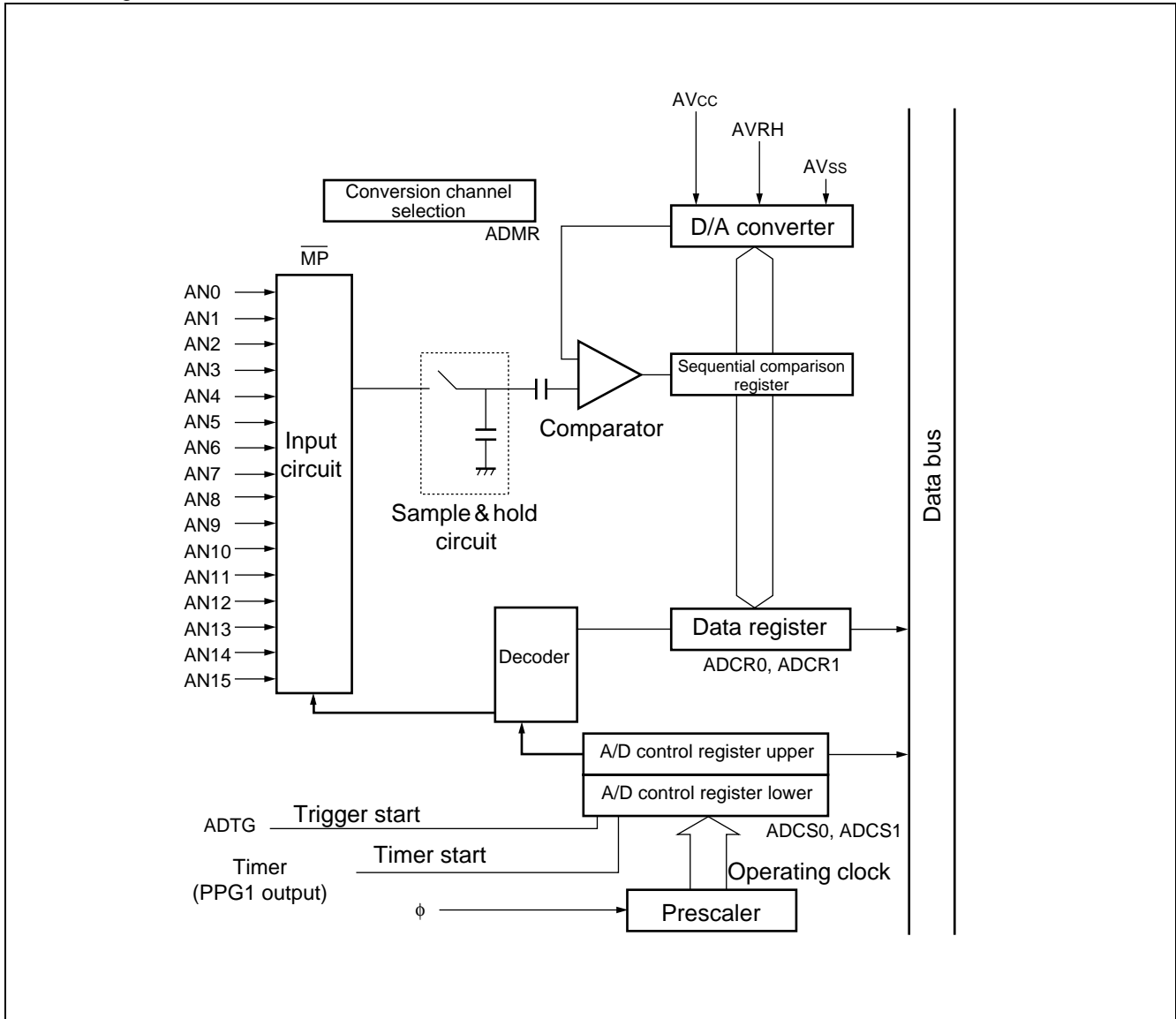

# MB90330 Series

## 13. DTP/External interrupt circuit

DTP (Data Transfer Peripheral)/External interrupt circuit detects the interrupt request input from the external interrupt input terminal (INT7 to INT0) , and outputs the interrupt request.

- DTP/External interrupt circuit function

The DTP/External interrupt function outputs an interrupt request upon detection of the edge or level signal input to the external interrupt input pins (INT7 to INT0).

If CPU accepts the interrupt request, and if the extended intelligent I/O service (EI<sup>2</sup>OS) is enabled, branches to the interrupt handling routine after completing the automatic data transfer (DTP function) performed by EI<sup>2</sup>OS. And if EI<sup>2</sup>OS is disabled, it branches to the interrupt handling routine without activating the automatic data transfer (DTP function) performed by EI<sup>2</sup>OS.

- Overview of DTP/External interrupt circuit

	External interrupt	DTP function
Input pin	8 channels (P60/INT0, P61/INT1, P62/INT2/SIN, P63/INT3/SOT, P64/INT4/SCK, P65/INT5/PWC, P66/INT6/SCL0, P67/INT7/SDA0)	
Interrupt source	The detection level or the type of the edge for each terminal can be set in the request level setting register (ELVR).	
	Input of H level/L level/rising edge/falling edge.	
Interrupt number	#18 (12 <sub>H</sub> ), #20 (14 <sub>H</sub> ), #22 (16 <sub>H</sub> ), #24 (18 <sub>H</sub> )	
Interrupt control	Enabling/disabling the interrupt request output using the DTP/interrupt enable register (ENIR)	
Interrupt flag	Holding the interrupt causes using the DTP/interrupt cause register (EIRR)	
Process setting	Disable EI <sup>2</sup> OS (ICR: ISE="0")	Enable EI <sup>2</sup> OS (ICR: ISE="1")
Process	Branched to the interrupt handling routine	After an automatic data transfer by EI <sup>2</sup> OS, branched to the interrupt handling routine



- Register list

DTP/Interrupt enable register (ENIR)

Address : 00003C <sub>H</sub>	7	6	5	4	3	2	1	0
	EN7	EN6	EN5	EN4	EN3	EN2	EN1	EN0
	(R/W)	(R/W)	(R/W)	(R/W)	(R/W)	(R/W)	(R/W)	(R/W)

Initial Value  
00000000<sub>B</sub>

DTP/Interrupt source register (EIRR)

Address : 00003D <sub>H</sub>	15	14	13	12	11	10	9	8
	ER7	ER6	ER5	ER4	ER3	ER2	ER1	ER0
	(R/W)	(R/W)	(R/W)	(R/W)	(R/W)	(R/W)	(R/W)	(R/W)

Initial Value  
00000000<sub>B</sub>

Request level setting register (ELVR)

Address : 00003E <sub>H</sub>	7	6	5	4	3	2	1	0
	LB3	LA3	LB2	LA2	LB1	LA1	LB0	LA0
	(R/W)	(R/W)	(R/W)	(R/W)	(R/W)	(R/W)	(R/W)	(R/W)

Initial Value  
00000000<sub>B</sub>

Address : 00003F <sub>H</sub>	15	14	13	12	11	10	9	8
	LB7	LA7	LB6	LA6	LB5	LA5	LB4	LA4
	(R/W)	(R/W)	(R/W)	(R/W)	(R/W)	(R/W)	(R/W)	(R/W)

Initial Value  
00000000<sub>B</sub>

# MB90330 Series

• Block Diagram

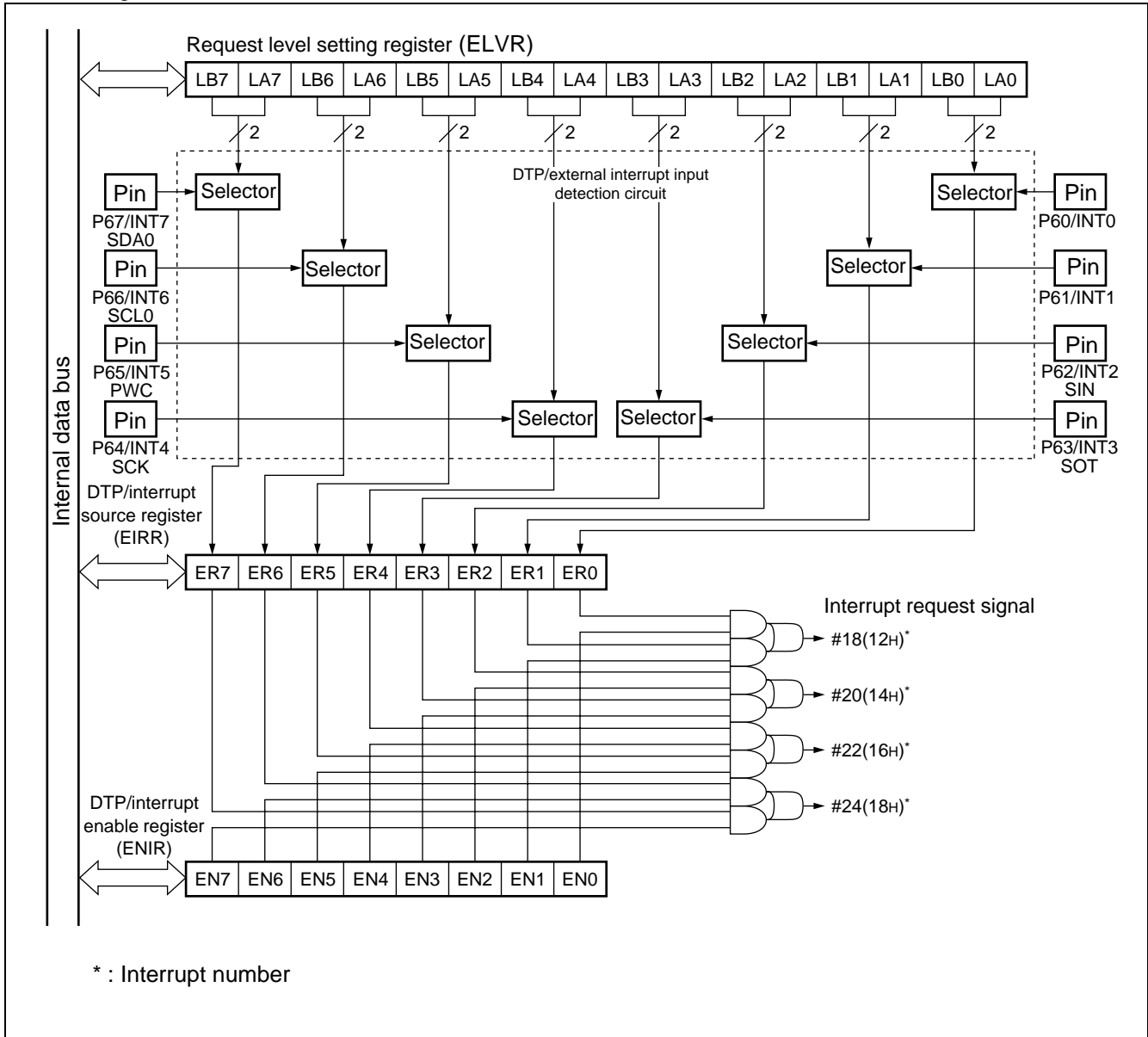

## 14. Interrupt controller

The interrupt control register is located inside the interrupt controller; it exists for every I/O having an interrupt function. This register has the following functions.

- Setting of the interrupt levels of relevant resources

### • Register list

Interrupt control register (ICR01, ICR03, ICR05, ICR07, ICR09, ICR11, ICR13, ICR15)		Initial Value
Address :	ICR01 : 0000B1H	00000111 <sub>B</sub>
	ICR03 : 0000B3H	
	ICR05 : 0000B5H	
	ICR07 : 0000B7H	
	ICR09 : 0000B9H	
	ICR11 : 0000BBH	
	ICR13 : 0000BDH	
	ICR15 : 0000BFH	

Interrupt control register (ICR00, ICR02, ICR04, ICR06, ICR08, ICR10, ICR12, ICR14)		Initial Value
Address :	ICR00 : 0000B0H	00000111 <sub>B</sub>
	ICR02 : 0000B2H	
	ICR04 : 0000B4H	
	ICR06 : 0000B6H	
	ICR08 : 0000B8H	
	ICR10 : 0000BAH	
	ICR12 : 0000BCH	
	ICR14 : 0000BEH	

Note : Do not access interrupt control registers using any read modify write instruction because it causes a malfunction.

### • Block Diagram

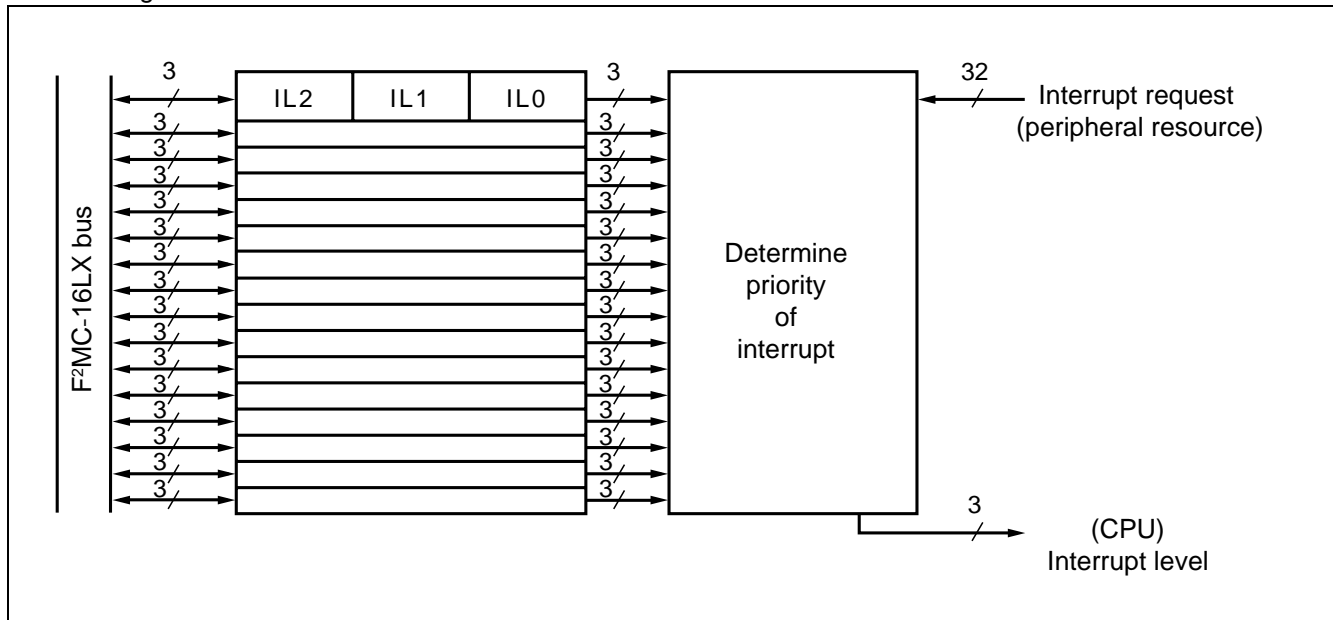

# MB90330 Series

## 15. $\mu$ DMAC

$\mu$ DMAC is simple DMA with the function equal with EI<sup>2</sup>OS. It has 16 channels DMA transfer channels with the following features.

- Performs automatic data transfer between the peripheral resource (I/O) and memory
- The program execution of CPU stops in the DMA start-up
- Capable of selecting whether to increment the transfer source and destination addresses
- DMA transfer is controlled by the DMA enable register, DMA stop status register, DMA status register, and descriptor.
- A STOP request is available for stopping DMA transfer from the resource.

Upon completion of DMA transfer, the flag bit corresponding to the transfer completed channel in the DMA status register is set and a termination interrupt is output to the transfer controller.

### • Register list

DMA enable register upper (DERH)								Initial Value	
Address : 0000AD <sub>H</sub>	15	14	13	12	11	10	9	8	00000000 <sub>B</sub>
	EN15	EN14	EN13	EN12	EN11	EN10	EN9	EN8	
	(R/W)	(R/W)	(R/W)	(R/W)	(R/W)	(R/W)	(R/W)	(R/W)	
DMA enable register lower (DERL)								Initial Value	
Address : 0000AC <sub>H</sub>	7	6	5	4	3	2	1	0	00000000 <sub>B</sub>
	EN7	EN6	EN5	EN4	EN3	EN2	EN1	EN0	
	(R/W)	(R/W)	(R/W)	(R/W)	(R/W)	(R/W)	(R/W)	(R/W)	
DMA stop status register (DSSR)								Initial Value	
Address : 0000A4 <sub>H</sub>	7	6	5	4	3	2	1	0	00000000 <sub>B</sub>
	STP7 STP15	STP6 STP14	STP5 STP13	STP4 STP12	STP3 STP11	STP2 STP10	STP1 STP9	STP0 STP8	*
	(R/W)	(R/W)	(R/W)	(R/W)	(R/W)	(R/W)	(R/W)	(R/W)	
DMA status register upper (DSRH)								Initial Value	
Address : 00009D <sub>H</sub>	15	14	13	12	11	10	9	8	00000000 <sub>B</sub>
	DTE15	DTE14	DTE13	DTE12	DTE11	DTE10	DTE9	DTE8	
	(R/W)	(R/W)	(R/W)	(R/W)	(R/W)	(R/W)	(R/W)	(R/W)	
DMA status register lower (DSRL)								Initial Value	
Address : 00009C <sub>H</sub>	7	6	5	4	3	2	1	0	00000000 <sub>B</sub>
	DTE7	DTE6	DTE5	DTE4	DTE3	DTE2	DTE1	DTE0	
	(R/W)	(R/W)	(R/W)	(R/W)	(R/W)	(R/W)	(R/W)	(R/W)	
DMA descriptor channel specification register (DCSR)								Initial Value	
Address : 00009B <sub>H</sub>	15	14	13	12	11	10	9	8	00000000 <sub>B</sub>
	STP	Reserved	Reserved	Reserved	DCSR3	DCSR2	DCSR1	DCSR0	
	(R/W)	(R/W)	(R/W)	(R/W)	(R/W)	(R/W)	(R/W)	(R/W)	

\* : The DSSR is lower when the STP bit of DCSR in the DSSR is "0".  
The DSSR is upper when the STP bit of DCSR in the DSSR is "1".

(Continued)

(Continued)

DMA buffer address pointer lower 8-bit (DBAPL)

Address : 007920 <sub>H</sub>	7	6	5	4	3	2	1	0	Initial Value XXXXXXXX <sub>B</sub>
	DBAPL	DBAPL	DBAPL	DBAPL	DBAPL	DBAPL	DBAPL	DBAPL	
	(R/W)	(R/W)	(R/W)	(R/W)	(R/W)	(R/W)	(R/W)	(R/W)	

DMA buffer address pointer middle 8-bit (DBAPM)

Address : 007921 <sub>H</sub>	15	14	13	12	11	10	9	8	Initial Value XXXXXXXX <sub>B</sub>
	DBAPM	DBAPM	DBAPM	DBAPM	DBAPM	DBAPM	DBAPM	DBAPM	
	(R/W)	(R/W)	(R/W)	(R/W)	(R/W)	(R/W)	(R/W)	(R/W)	

DMA buffer address pointer upper 8-bit (DBAPH)

Address : 007922 <sub>H</sub>	7	6	5	4	3	2	1	0	Initial Value XXXXXXXX <sub>B</sub>
	DBAPH	DBAPH	DBAPH	DBAPH	DBAPH	DBAPH	DBAPH	DBAPH	
	(R/W)	(R/W)	(R/W)	(R/W)	(R/W)	(R/W)	(R/W)	(R/W)	

DMA control register (DMACS)

Address : 007923 <sub>H</sub>	15	14	13	12	11	10	9	8	Initial Value XXXXXXXX <sub>B</sub>
	RDY2	RDY1	BYTEL	IF	BW	BF	DIR	SE	
	(R/W)	(R/W)	(R/W)	(R/W)	(R/W)	(R/W)	(R/W)	(R/W)	

DMA I/O register address pointer lower 8-bit (DIOAL)

Address : 007924 <sub>H</sub>	7	6	5	4	3	2	1	0	Initial Value XXXXXXXX <sub>B</sub>
	A07	A06	A05	A04	A03	A02	A01	A00	
	(R/W)	(R/W)	(R/W)	(R/W)	(R/W)	(R/W)	(R/W)	(R/W)	

DMA I/O register address pointer upper 8-bit (DIOAH)

Address : 007925 <sub>H</sub>	15	14	13	12	11	10	9	8	Initial Value XXXXXXXX <sub>B</sub>
	A15	A14	A13	A12	A11	A10	A09	A08	
	(R/W)	(R/W)	(R/W)	(R/W)	(R/W)	(R/W)	(R/W)	(R/W)	

DMA data counter lower 8-bit (DDCTL)

Address : 007926 <sub>H</sub>	7	6	5	4	3	2	1	0	Initial Value XXXXXXXX <sub>B</sub>
	B07	B06	B05	B04	B03	B02	B01	B00	
	(R/W)	(R/W)	(R/W)	(R/W)	(R/W)	(R/W)	(R/W)	(R/W)	

DMA data counter upper 8-bit (DDCTH)

Address : 007927 <sub>H</sub>	15	14	13	12	11	10	9	8	Initial Value XXXXXXXX <sub>B</sub>
	B15	B14	B13	B12	B11	B10	B09	B08	
	(R/W)	(R/W)	(R/W)	(R/W)	(R/W)	(R/W)	(R/W)	(R/W)	

Note : The above register is switched for each channel depending on the DCSR.

# MB90330 Series

## 16. External bus pin control circuit

The external bus pin control circuit controls external bus pins to extend the CPU address and data buses to externals.

### • Register list

- Automatic ready function selection register (ARSR)

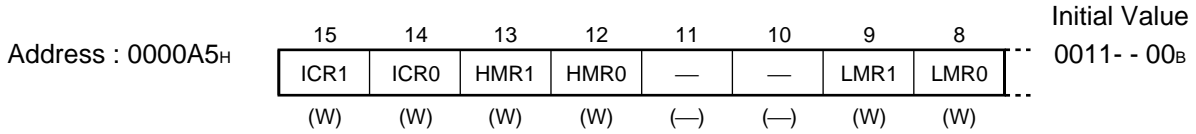

- External address output control register (HACR)

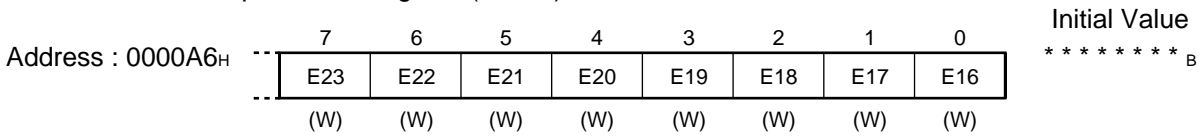

- Bus control signal selection register (EPCR)

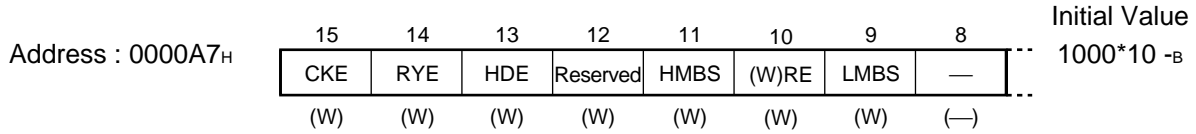

W :Write only  
 — :Unused  
 \* :“1” or “0”

### • Block Diagram

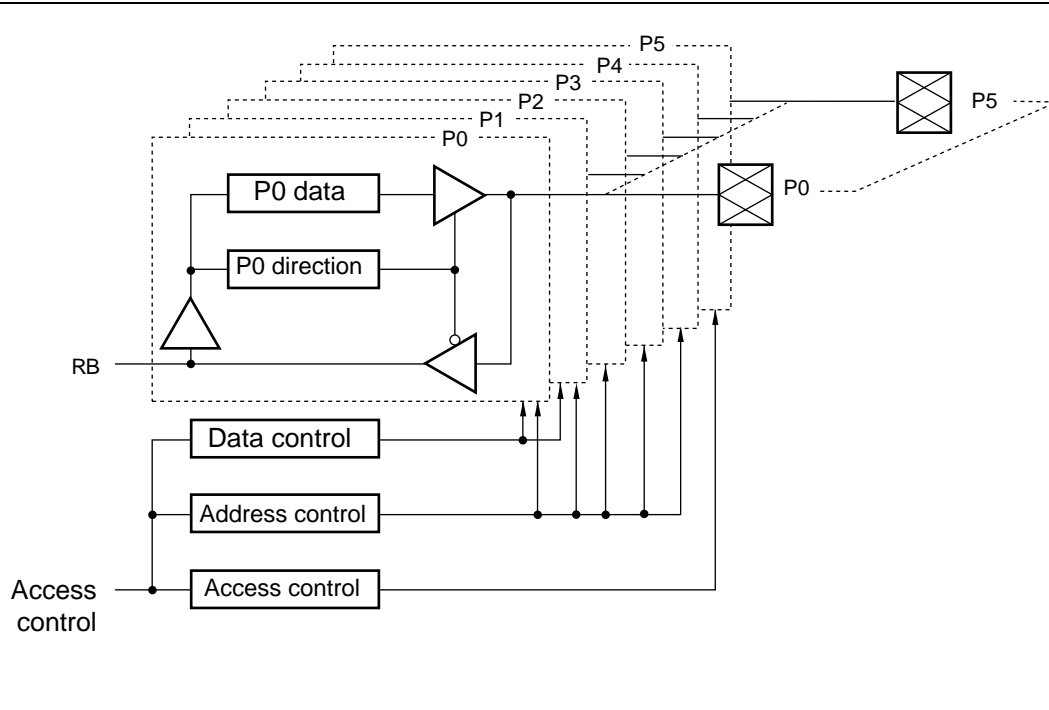

## 17. Address matching detection function

When the address is equal to the value set in the address detection register, the instruction code to be read into the CPU is forcibly replaced with the INT9 instruction code (01H). As a result, the CPU executes the INT9 instruction when executing the set instruction. By performing processing by the INT#9 interrupt routine, the program patch function is enabled.

2 address detection registers are provided, for each of which there is an interrupt enable bit. When the address matches the value set in the address detection register with the interrupt enable bit set to 1, the instruction code to be read into the CPU is forcibly replaced with the INT9 instruction code.

### • Register list

#### • Program address detect register 0 to 2 (PADR0)

##### PADR0 (lower)

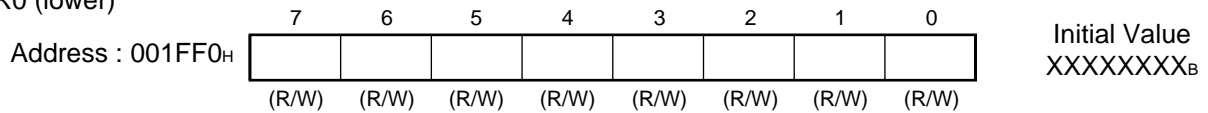

##### PADR0 (middle)

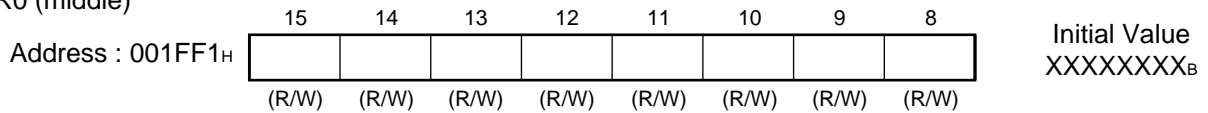

##### PADR0 (upper)

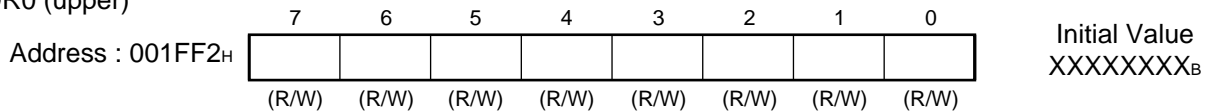

#### • Program address detect register 3 to 5 (PADR1)

##### PADR1 (lower)

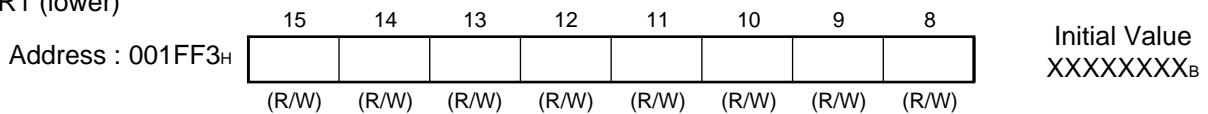

##### PADR1 (middle)

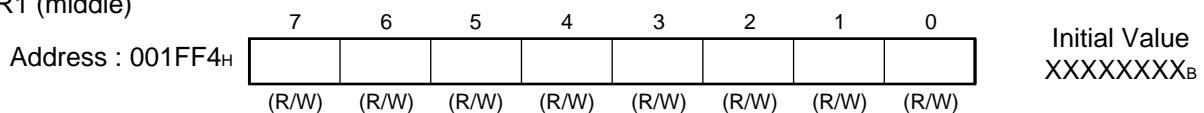

##### PADR1 (upper)

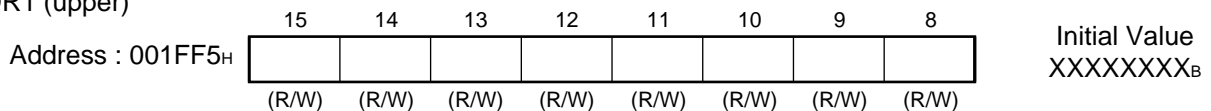

#### • Program address detection control status register (PACSR)

##### PACSR

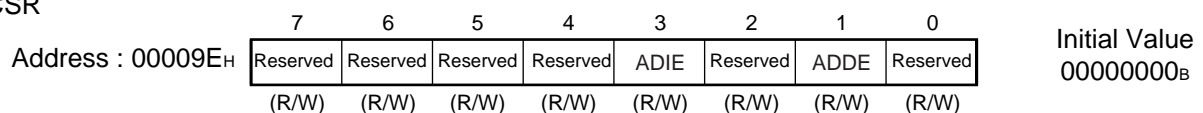

R/W : Readable and Writable

X : Undefined

## 18. Delay interrupt generator module

The delay interrupt generation module is a module that generates interrupts for switching tasks. A hardware interrupt can be generated by software.

### • Delay interrupt generator module function

	Function and control
Interrupt source	<ul style="list-style-type: none"> <li>Setting the R0 bit in the delayed interrupt request generation/release register to 1 (DIRR: R0 = 1) generates a delayed interrupt request.</li> <li>Setting the R0 bit in the delayed interrupt request generation/release register to 0 (DIRR: R0 = 0) cancels the delayed interrupt request.</li> </ul>
Interrupt control	No setting of permission register is provided.
Interrupt flag	Set in bit R0 of the delayed interrupt request generation /clear register (DIRR : R0)
EI <sup>2</sup> OS support	Not ready for extended intelligent I/O service (EI <sup>2</sup> OS).

### • Block Diagram

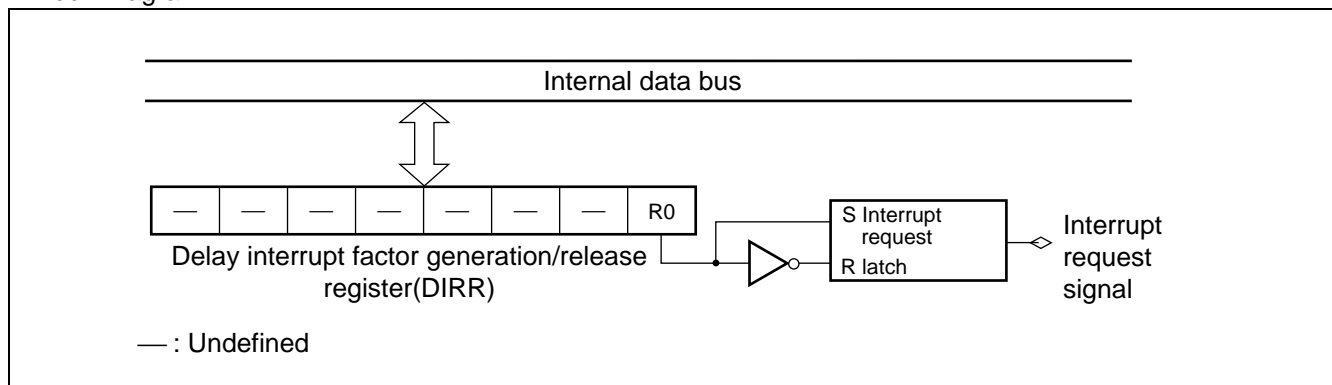



## 19. ROM mirror function selection module

The ROM mirror function select module can make a setting so that ROM data located in bank FF can be read by accessing bank 00.

- ROM mirroring function selection module function

	Description
Mirror setting address	FFFFFF <sub>H</sub> to FF8000 <sub>H</sub> in the FF bank can be read through 00FFFF <sub>H</sub> to 008000 <sub>H</sub> in the 00 bank.
Interrupt source	None.
EI <sup>2</sup> OS support	Not ready for extended intelligent I/O service (EI <sup>2</sup> OS) .

- Block Diagram

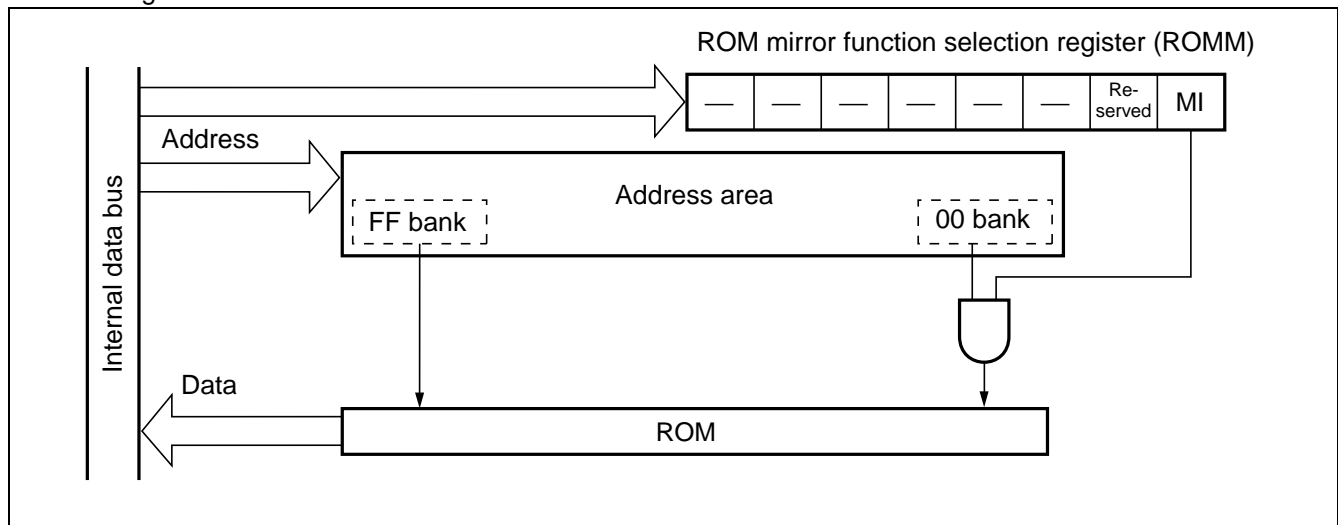

# MB90330 Series

## 20. Low power consumption (standby) mode

The F<sup>2</sup>MC-16LX can be set to save power consumption by selecting and setting the low power consumption mode.

### • CPU operation mode and functional description

CPU operating clock	Operation mode	Description
PLL clock	Normal run	The CPU and peripheral resources operate at the clock frequency obtained by PLL multiplication of oscillator clock (HCLK) frequency.
	Sleep	Only peripheral resources operate at the clock frequency obtained by PLL multiplication of the oscillator clock (HCLK) .
	Time-base timer	Only the time-base timer operates at the clock frequency obtained by PLL multiplication of the oscillator clock (HCLK) frequency.
	Stop	The CPU and peripheral resources are suspended with the oscillator clock stopped.
Main clock	Normal run	The CPU and peripheral resources operate at the clock frequency obtained by dividing the oscillator clock (HCLK) frequency by two.
	Sleep	Only peripheral resources operate at the clock frequency obtained by dividing the oscillator clock (HCLK) frequency by two.
	Time-base timer	Only the time-base timer operates at the clock frequency obtained by dividing the oscillator clock (HCLK) frequency by two.
	Stop	The CPU and peripheral resources are suspended with the oscillator clock stopped.
Sub clock	Normal run	The CPU and peripheral resources operate at the clock frequency obtained by dividing the subclock (SCLK) frequency by four.
	Sleep	Only peripheral resources operate at the clock frequency obtained by dividing the subclock (SCLK) frequency by four.
	Watch mode	Only the watch timer operates at the clock frequency obtained by dividing the subclock (SCLK) frequency by four.
	Stop	The CPU and peripheral resources are suspended with the subclock stopped.
CPU intermittent operation mode	Normal run	The halved or PLL-multiplied oscillator clock (HCLK) frequency or the subclock (SCLK) frequency is used for operation while being decimated in a certain period.

### • Register list

Low power consumption mode control register (LPMCR)								Initial Value	
Address : 0000A0H	7	6	5	4	3	2	1	0	00011000 <sub>B</sub>
	STP	SLP	SPL	RST	TMD	CG1	CG0	Reserved	
	(W)	(W)	(R/W)	(W)	(R/W)	(R/W)	(R/W)	(R/W)	

## 21. Clock

The clock generator controls the internal clock as the operating clock for the CPU and peripheral resources. The internal clock is referred to as machine clock whose one cycle is defined as machine cycle. The clock based on source oscillation is referred to as oscillator clock while the clock based on internal PLL oscillation is referred to as PLL clock.

- Register list

Clock selection register (CKSCR)								Initial Value	
Address : 0000A1 <sub>H</sub>	15	14	13	12	11	10	9	8	11111100 <sub>B</sub>
	SCM	MCM	WS1	WS0	SCS	MCS	CS1	CS0	
	(R)	(R)	(R/W)	(R/W)	(R/W)	(R/W)	(R/W)	(R/W)	

# MB90330 Series

## 22. 3 Mbits flash memory

The description that follows applies to the flash memory built in the MB90F334A; it is not applicable to evaluation ROM or masked ROM.

The flash memory is located in bank FF in the CPU memory map.

### • Function to flash memory

	Description
Memory capacity	3072 Kbits (384 KB)
Memory configuration	384 Kwords × 8 bits/192 Kwords × 16 bits
Sector configuration	64 KB × 5 + 32 KB + 8 KB × 2 + 16 KB
Sector protect function	Possibility that set up with a recommendation parallel writer
Program algorithm	Automatic program algorithm (Embedded Algorithm* : Similar to MBM29LV400TC)
Operation command	<ul style="list-style-type: none"><li>• Compatibility with the JEDEC standard-type command</li><li>• Built-in deletion pause/deletion resume function</li><li>• Detection of programming/erasure completion using data polling and the toggle bit</li><li>• Capable of erasing data sector by sector (in arbitrary combination of sectors)</li></ul>
Program/Erase cycle	At least 10,000 times guaranteed
How to program and erase memory	<ul style="list-style-type: none"><li>• Parallel programmer available for programming and erasure (Ando Denki : AF9708, AF9709, AF9709B)</li><li>• Can be written and erased using a dedicated serial writer (Yokogawa Digital Computer Corporation : AF220/AF210/AF120/AF110)</li><li>• Write/delete operation by program execution</li></ul>
Interrupt source	Programming/erasure completion sources
EI <sup>2</sup> OS supports	Not ready for expanded intelligent I/O service (EI <sup>2</sup> OS).

\* : Embedded Algorithm is a trade mark of Advanced Micro Devices Inc.

- Sector configuration of flash memory

Flash Memory CPU address Writer address *		
Prohibited	F80000H	00000H
	F8FFFFH	0FFFFH
SA0 (64 KB)	F90000H	10000H
	F9FFFFH	1FFFFH
SA1 (64 KB)	FA0000H	20000H
	FAFFFFH	2FFFFH
SA2 (64 KB)	FB0000H	30000H
	FBFFFFH	3FFFFH
Prohibited	FC0000H	40000H
	FCFFFFH	4FFFFH
SA3 (64 KB)	FD0000H	50000H
	FDFFFFH	5FFFFH
SA4 (64 KB)	FE0000H	60000H
	FEFFFFH	6FFFFH
SA5 (32 KB)	FF0000H	70000H
	FF7FFFH	77FFFH
SA6 (8 KB)	FF8000H	78000H
	FF9FFFH	79FFFH
SA7 (8 KB)	FFA000H	7A000H
	FFBFFFH	7BFFFH
SA8 (16 KB)	FFC000H	7C000H
	FFFFFFH	7FFFFH

\* : The writer address is relative to the CPU address when data is programmed into flash memory by a parallel programmer. Programming and erasing by the general-purpose parallel programmer are executed based on writer addresses.

- Register list

Flash memory control register (FMCS)								Initial Value	
Address : 0000AE <sub>H</sub>	7	6	5	4	3	2	1	0	000X0000 <sub>B</sub>
	INTE	RDYINT	WE	RDY	Reserved	LPM1	Reserved	LPM0	
	(R/W)	(R/W)	(R/W)	(R)	(W)	(R/W)	(W)	(R/W)	

# MB90330 Series

- Standard configuration for Fujitsu standard serial on-board writing

The flash microcontroller programmer (AF220/AF210/AF120/AF110) made by Yokogawa Digital Computer Corporation is used for Fujitsu standard serial on-board writing.

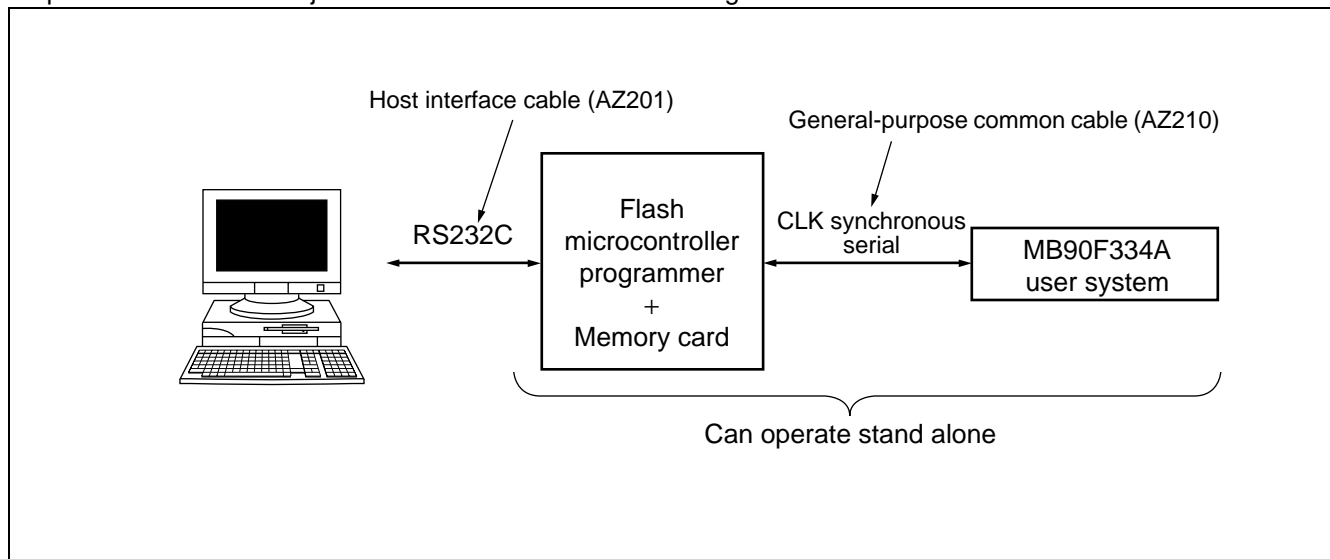

Note : Inquire of Yokogawa Digital Computer Corporation for details about the functions and operations of the AF220, AF210, AF120 and AF110 flash microcontroller programmer, general-purpose common cable for connection (AZ210) and connectors.

- Pins Used for Fujitsu Standard Serial On-board Programming

Pin	Function	Description
MD2, MD1, MD0	Mode input pin	The device enters the serial program mode by setting MD2=1, MD1=1 and MD0 =0.
X0, X1	Oscillation pin	Because the internal CPU operation clock is set to be the 1 multiplication PLL clock in the serial write mode, the internal operation clock frequency is the same as the oscillation clock frequency.
P60, P61	Programming program start pins	Input a Low level to P60 and a High level to P61.
$\overline{RST}$	Reset input pin	—
SIN0	Serial data input pin.	UART0 is used as CLK synchronous mode.
SOT0	Serial data output pin	In program mode, the pins used for the UART0 CLK synchronous mode are SIN0, SOT0 and SCK0.
SCK0	Serial clock input pin	
V <sub>cc</sub>	Power source input pin	When supplying the write voltage (MB90F334A : 3.3 V $\pm$ 0.3 V) from the user system, connection with the flash microcontroller programmer is not necessary. When connecting, do not short-circuit with the user power supply.
V <sub>ss</sub>	GND Pin	Share GND with the flash microcontroller programmer.

The control circuit shown in the figure is required for using the P60, P61, SIN0, SOT0 and SCK0 pins on the user system. Isolate the user circuit during serial on-board writing, with the TICS signal of the flash microcontroller programmer.

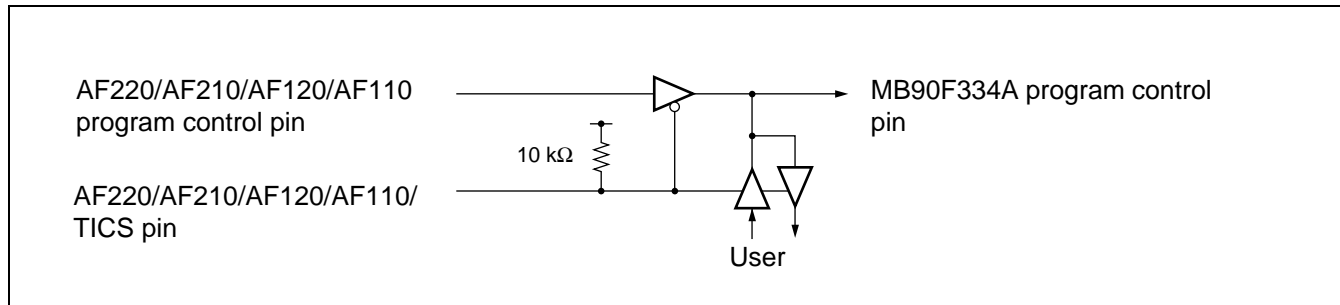

Control circuit

The MB90F334A serial clock frequency that can be input is determined by the following expression:  
Use the flash microcontroller programmer to change the serial clock input frequency setting depending on the oscillator clock frequency to be used.

$$\text{Inputable serial clock frequency} = 0.125 \times \text{oscillation clock frequency.}$$

- Maximum serial clock frequency

Oscillation clock frequency	Maximum serial clock frequency acceptable to the microcontroller	Maximum serial clock frequency that can be set with the AF220, AF210, AF120 or AF110	Maximum serial clock frequency that can be set with the AF200
At 6 MHz	750 kHz	500 kHz	500 kHz

- System configuration of the flash microcontroller programmer (AF220/AF210/AF120/AF110) (made by Yokogawa Digital Computer Corporation)

Part number		Function	
Unit	AF220/AC4P	Model with internal Ethernet interface	/100 V to 220 V power adapter
	AF210/AC4P	Standard model	/100 V to 220 V power adapter
	AF120/AC4P	Single key internal Ethernet interface mode	/100 V to 220 V power adapter
	AF110/AC4P	Single key model	/100 V to 220 V power adapter
AZ221		PC/AT RS232C cable for writer	
AZ210		Standard target probe (a) length : 1 m	
FF201		Control module for Fujitsu F <sup>2</sup> MC-16LX flash microcontroller control module	
AZ290		Remote controller	
/P4		4 MB PC Card (option) Flash memory capacity to 512 KB correspondence	

Contact to : Yokogawa Digital Computer Corporation TEL : 81-423-33-6224

Note : The AF200 flash microcontroller programmer is a retired product, but it can be supported using control module FF201.

# MB90330 Series

## ■ ELECTRICAL CHARACTERISTICS

### 1. Absolute Maximum Ratings

Parameter	Symbol	Rating		Unit	Remarks
		Min	Max		
Power supply voltage*1	V <sub>CC</sub>	V <sub>SS</sub> - 0.3	V <sub>SS</sub> + 4.0	V	
	AV <sub>CC</sub>	V <sub>SS</sub> - 0.3	V <sub>SS</sub> + 4.0	V	V <sub>CC</sub> ≥ AV <sub>CC</sub> *2
	AVRH	V <sub>SS</sub> - 0.3	V <sub>SS</sub> + 4.0	V	AV <sub>CC</sub> ≥ AVR ≥ 0 V*3
Input voltage*1	V <sub>I</sub>	V <sub>SS</sub> - 0.3	V <sub>SS</sub> + 4.0	V	*4
		V <sub>SS</sub> - 0.3	V <sub>SS</sub> + 6.0	V	Nch open-drain (Withstand voltage of 5 V I/O)*5
		- 0.5	V <sub>SS</sub> + 4.5	V	USB I/O
Output voltage*1	V <sub>O</sub>	V <sub>SS</sub> - 0.3	V <sub>SS</sub> + 4.0	V	*4
		- 0.5	V <sub>SS</sub> + 4.5	V	USB I/O
Maximum clamp current	I <sub>CLAMP</sub>	- 2.0	+2.0	mA	*6
Total maximum clamp current	Σ  I <sub>CLAMP</sub>	—	20	mA	*6
“L” level maximum output current	I <sub>OL1</sub>	—	10	mA	Other than USB I/O*7
	I <sub>OL2</sub>	—	43	mA	USB I/O*7
“L” level average output current	I <sub>OLAV</sub>	—	3	mA	*8
“L” level maximum total output current	ΣI <sub>OL</sub>	—	60	mA	
“L” level average total output current	ΣI <sub>OLAV</sub>	—	30	mA	*9
“H” level maximum output current	I <sub>OH1</sub>	—	- 10	mA	Other than USB I/O*7
	I <sub>OH2</sub>	—	- 43	mA	USB I/O*7
“H” level average output current	I <sub>OHAV</sub>	—	- 3	mA	*8
“H” level maximum total output current	ΣI <sub>OH</sub>	—	- 60	mA	
“H” level average total output current	ΣI <sub>OHAV</sub>	—	- 30	mA	*9
Power consumption	P <sub>d</sub>	—	340	mW	
Operating temperature	T <sub>A</sub>	- 40	+ 85	°C	
Storage temperature	T <sub>stg</sub>	- 55	+ 150	°C	
		- 55	+ 125	°C	USB I/O

\*1 : The parameter is based on V<sub>SS</sub> = AV<sub>SS</sub> = 0.0 V.

\*2 : Be careful not to let AV<sub>CC</sub> exceed V<sub>CC</sub>, for example, when the power is turned on.

\*3 : Be careful not to let AVRH exceed AV<sub>CC</sub>.

\*4 : V<sub>I</sub> and V<sub>O</sub> must not exceed V<sub>CC</sub> + 0.3 V. However, if the maximum current to/from an input is limited by some means with external components, the I<sub>CLAMP</sub> rating supersedes the V<sub>I</sub> rating.

\*5 : Applicable to pins : P60 to P67, P96, PA0 to PA7, PB0 to PB4, VBUS

\*6 : • Applicable to pins: P00 to P07, P10 to P17, P20 to P27, P30 to P37, P40 to P47, P50 to P57, P70 to P77, P80 to P87, P90 to P95, PB5, PB6

- Use within recommended operating conditions.
- Use at DC voltage (current)
- The +B signal should always be applied a limiting resistance placed between the +B signal and the microcontroller.



- The value of the limiting resistance should be set so that when the +B signal is applied the input current to the microcontroller pin does not exceed rated values, either instantaneously or for prolonged periods.
- Note that when the microcontroller drive current is low, such as in the power saving modes, the +B input potential may pass through the protective diode and increase the potential at the V<sub>CC</sub> pin, and this may affect other devices.
- Note that if a +B signal is input when the microcontroller power supply is off (not fixed at 0 V), the power supply is provided from the pins, so that incomplete operation may result.
- Note that if the +B input is applied during power-on, the power supply is provided from the pins and the resulting supply voltage may not be sufficient to operate the power-on reset.
- Care must be taken not to leave the +B input pin open.
- Note that analog system input/output pins other than P60 to P67, P96, PA0 to PA7, PB0 to PB4, DVP, DVM, HVP, HVM, VBUS, HCON
- Sample recommended circuits:

- Input/output equivalent circuits

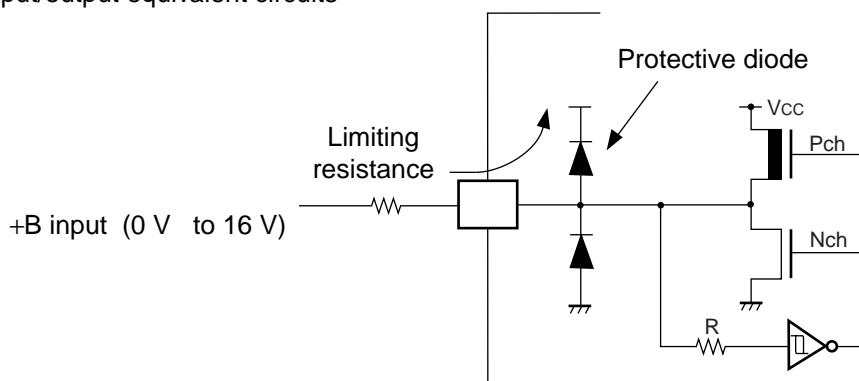

- \*7 : A peak value of an applicable one pin is specified as a maximum output current.
- \*8 : The average output current specifies the mean value of the current flowing in the relevant single pin during a period of 100 ms.
- \*9 : The average total output current specifies the mean value of the currents flowing in all of the relevant pins during a period of 100 ms.

**WARNING:** Semiconductor devices can be permanently damaged by application of stress (voltage, current, temperature, etc.) in excess of absolute maximum ratings. Do not exceed these ratings.

# MB90330 Series

## 2. Recommended Operating Conditions

( $V_{SS} = AV_{SS} = 0.0\text{ V}$ )

Parameter	Symbol	Value		Unit	Remarks
		Min	Max		
Power supply voltage	$V_{CC}$	3.0	3.6	V	At normal operation (when using USB)
		2.7	3.6	V	At normal operation (when not using USB)
		1.8	3.6	V	Hold state of stop operation
Input "H" voltage	$V_{IH}$	$0.7 V_{CC}$	$V_{CC} + 0.3$	V	CMOS input pin
	$V_{IHS1}$	$0.8 V_{CC}$	$V_{CC} + 0.3$	V	CMOS hysteresis input pin
	$V_{IHS2}$	$0.8 V_{CC}$	$V_{SS} + 5.3$	V	Nch open-drain (Withstand voltage of 5 V I/O)*
	$V_{IHM}$	$V_{CC} - 0.3$	$V_{CC} + 0.3$	V	MD pin input
	$V_{IHUSB}$	2.0	$V_{CC} + 0.3$	V	USB pin input
Input "L" voltage	$V_{IL}$	$V_{SS} - 0.3$	$0.3 V_{CC}$	V	CMOS input pin
	$V_{ILS}$	$V_{SS} - 0.3$	$0.2 V_{CC}$	V	CMOS hysteresis input pin
	$V_{ILM}$	$V_{SS} - 0.3$	$V_{SS} + 0.3$	V	MD pin input
	$V_{ILUSB}$	$V_{SS}$	0.8	V	USB pin input
Differential input sensitivity	$V_{DI}$	0.2	—	V	USB pin input
Differential common mode input voltage range	$V_{CM}$	0.8	2.5	V	USB pin input
Series resistance	$R_S$	25	30	$\Omega$	Recommended value = 27 $\Omega$ at using USB
Operating temperature	$T_A$	- 40	+ 85	$^{\circ}\text{C}$	When not using USB
		0	+ 70	$^{\circ}\text{C}$	When using USB

\* : Applicable to pins : P60 to P67, P96, PA0 to PA7, PB0 to PB4, VBUS

**WARNING:** The recommended operating conditions are required in order to ensure the normal operation of the semiconductor device. All of the device's electrical characteristics are warranted when the device is operated within these ranges.

Always use semiconductor devices within their recommended operating condition ranges. Operation outside these ranges may adversely affect reliability and could result in device failure.

No warranty is made with respect to uses, operating conditions, or combinations not represented on the data sheet. Users considering application outside the listed conditions are advised to contact their FUJITSU representatives beforehand.

# MB90330 Series

## 3. DC Characteristics

( $V_{CC} = AV_{CC} = 3.3 \text{ V} \pm 0.3 \text{ V}$ ,  $V_{SS} = AV_{SS} = 0.0 \text{ V}$ ,  $T_A = -40 \text{ }^\circ\text{C}$  to  $+85 \text{ }^\circ\text{C}$ )

Parameter	Symbol	Pin name	Conditions	Value			Unit	Remarks
				Min	Typ	Max		
Output "H" voltage	$V_{OH}$	Output pins other than P60 to P67, P96, PA0 to PA7, PB0 to PB4, HVP, HVM, DVP, DVM	$I_{OH} = -4.0 \text{ mA}$	$V_{CC} - 0.5$	—	$V_{CC}$	V	
		HVP, HVM, DVP, DVM	$R_L = 15 \text{ k}\Omega \pm 5\%$	2.8	—	3.6	V	
Output "L" voltage	$V_{OL}$	Output pins other than HVP, HVM, DVP, DVM	$I_{OL} = 4.0 \text{ mA}$	$V_{SS}$	—	$V_{SS} + 0.4$	V	
		HVP, HVM, DVP, DVM	$R_L = 1.5 \text{ k}\Omega \pm 5\%$	0	—	0.3	V	
Input leak current	$I_{IL}$	Output pins other than P60 to P67, P96, PA0 to PA7, PB0 to PB4, HVP, HVM, DVP, DVM	$V_{CC} = 3.3 \text{ V}$ , $V_{SS} < V_i < V_{CC}$	-10	—	+10	$\mu\text{A}$	
		HVP, HVM, DVP, DVM	—	-5	—	+5	$\mu\text{A}$	
Pull-up resistance	$R_{PULL}$	P00 to P07, P10 to P17	$V_{CC} = 3.3 \text{ V}$ , $T_A = +25 \text{ }^\circ\text{C}$	25	50	100	$\text{k}\Omega$	
Open drain output current	$I_{LIOD}$	P60 to P67, P96, PA0 to PA7, PB0 to PB4,	—	—	0.1	10	$\mu\text{A}$	
Power supply current	$I_{CC}$	$V_{CC}$	$V_{CC} = 3.3 \text{ V}$ , Internal frequency 24 MHz, At normal operating	—	75	85	$\text{mA}$	MB90F334A
			At USB operating (USTP = 0)	—	65	75	$\text{mA}$	MB90333A
			$V_{CC} = 3.3 \text{ V}$ , Internal frequency 24 MHz, At normal operating	—	70	80	$\text{mA}$	MB90F334A
			At non-operating USB (USTP = 1)	—	60	70	$\text{mA}$	MB90333A
	$I_{CCS}$		$V_{CC} = 3.3 \text{ V}$ , Internal frequency 24 MHz, At sleep mode	—	27	40	$\text{mA}$	
	$I_{CTS}$		$V_{CC} = 3.3 \text{ V}$ , Internal frequency 24 MHz, At timer mode	—	3.5	10	$\text{mA}$	
			$V_{CC} = 3.3 \text{ V}$ , Internal frequency 3 MHz, At timer mode	—	1	2	$\text{mA}$	
$I_{CCL}$	$V_{CC} = 3.3 \text{ V}$ , Internal frequency 8 kHz, At subclock operation, ( $T_A = +25 \text{ }^\circ\text{C}$ )	—	25	150	$\mu\text{A}$			

(Continued)

# MB90330 Series

(Continued)

( $V_{CC} = AV_{CC} = 3.3 \text{ V} \pm 0.3 \text{ V}$ ,  $V_{SS} = AV_{SS} = 0.0 \text{ V}$ ,  $T_A = -40 \text{ }^\circ\text{C}$  to  $+85 \text{ }^\circ\text{C}$ )

Parameter	Symbol	Pin name	Conditions	Value			Unit	Remarks
				Min	Typ	Max		
Power supply current	$I_{CCL}$	$V_{CC}$	$V_{CC} = 3.3 \text{ V}$ , Internal frequency 8 kHz, At sub clock, At sleep operating, ( $T_A = +25 \text{ }^\circ\text{C}$ )	—	10	50	$\mu\text{A}$	
	$I_{CCT}$		$V_{CC} = 3.3 \text{ V}$ , Internal frequency 8 kHz, Watch mode, ( $T_A = +25 \text{ }^\circ\text{C}$ )	—	1.5	40	$\mu\text{A}$	
	$I_{CCH}$		$T_A = +25 \text{ }^\circ\text{C}$ , At stop	—	1	40	$\mu\text{A}$	
Input capacitance	$C_{IN}$	Other than $AV_{CC}$ , $AV_{SS}$ , $V_{CC}$ , $V_{SS}$	—	—	5	15	$\text{pF}$	
Pull-up resistor	$R_{up}$	$\overline{RST}$	—	25	50	100	$\text{k}\Omega$	

Note : P60 to P67, P96, PA0 to PA7, and PB0 to PB4 are Nch open-drain pins usually used as CMOS.

## 4. AC Characteristics

### (1) Clock input timing

( $V_{CC} = AV_{CC} = 3.3 \text{ V} \pm 0.3 \text{ V}$ ,  $V_{SS} = AV_{SS} = 0.0 \text{ V}$ ,  $T_A = -40 \text{ }^\circ\text{C}$  to  $+85 \text{ }^\circ\text{C}$ )

Parameter	Symbol	Pin name	Value			Unit	Remarks
			Min	Typ	Max		
Clock frequency	$f_{CH}$	X0, X1	—	6	—	MHz	External crystal oscillation
			6	—	24	MHz	External clock input
	$f_{CL}$	X0A, X1A	—	32.768	—	kHz	
Clock cycle time	$t_{HCYL}$	X0, X1	—	166.7	—	ns	External crystal oscillation
			166.7	—	41.7	ns	External clock input
	$t_{LCYL}$	X0A, X1A	—	30.5	—	s	
Input clock pulse width	$P_{WH}$ $P_{WL}$	X0	10	—	—	ns	A reference duty ratio is 30% to 70%.
	$P_{WHL}$ $P_{WLL}$	X0A	—	15.2	—	s	
Input clock rise time and fall time	$t_{cr}$ $t_{cf}$	X0	—	—	5	ns	At external clock
Internal operating clock frequency	$f_{CP}$	—	3	—	24	MHz	When main clock is used
	$f_{CPL}$	—	—	8.192	—	kHz	When sub clock is used
Internal operating clock cycle time	$t_{CP}$	—	42	—	333	ns	When main clock is used
	$t_{CPL}$	—	—	122.1	—	s	When sub clock is used

#### • Clock Timing

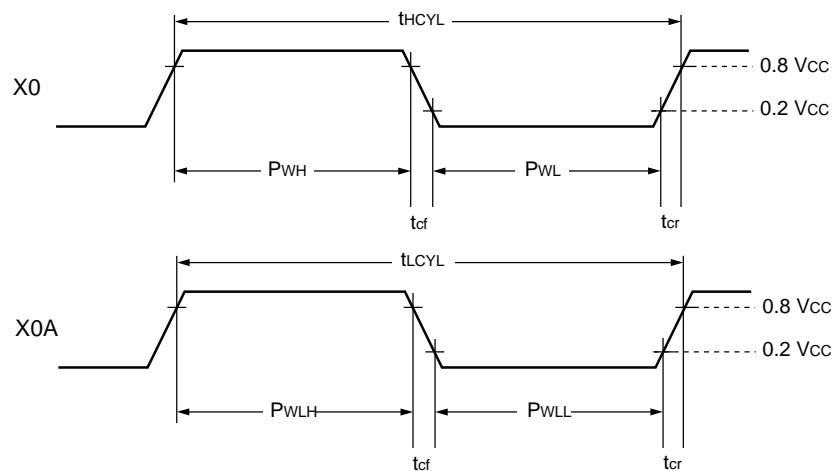

# MB90330 Series

- PLL operation guarantee range

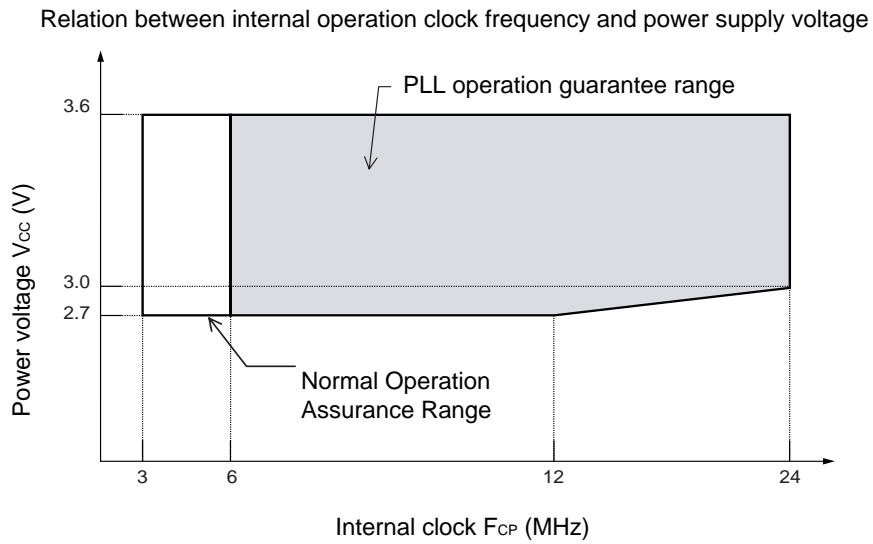

Note : When the USB is used, operation is guaranteed at voltages between 3.0 V and 3.6 V.

Relation between oscillation frequency and internal operation clock frequency

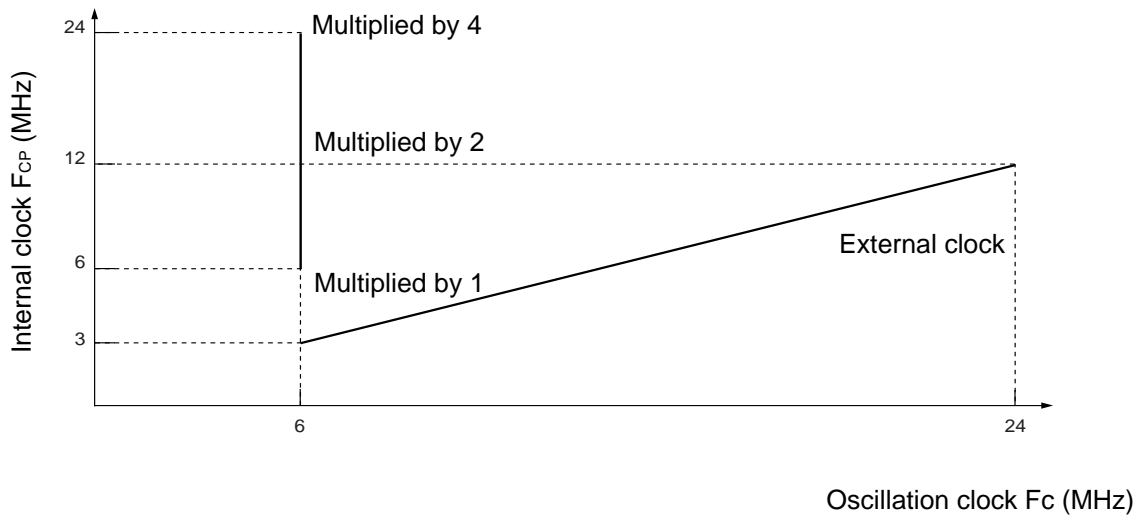

The AC standards assume the following measurement reference voltages.

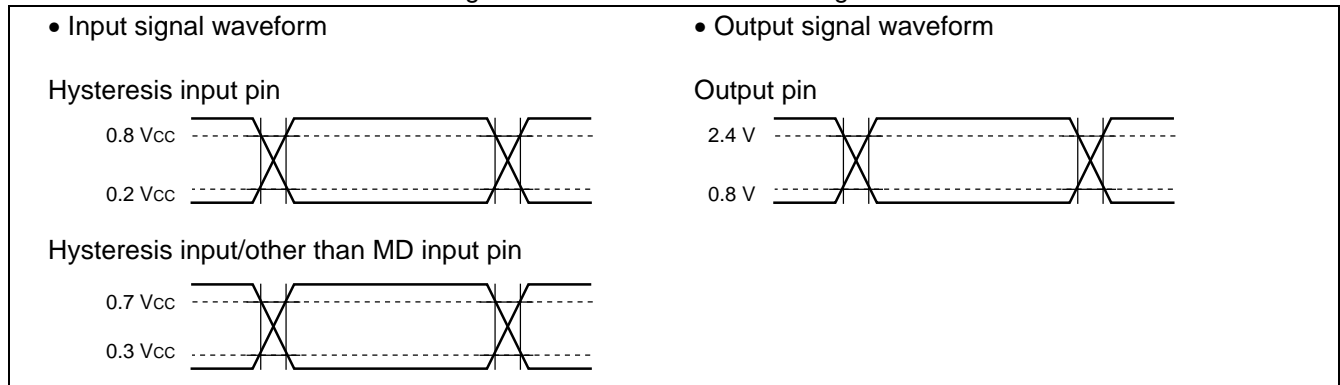

# MB90330 Series

## (2) Clock output timing

( $V_{SS} = AV_{SS} = 0.0\text{ V}$ ,  $T_A = -40\text{ }^\circ\text{C}$  to  $+85\text{ }^\circ\text{C}$ )

Parameter	Symbol	Pin name	Conditions	Value		Unit	Remarks
				Min	Max		
Cycle time	$t_{CYC}$	CLK	—	$t_{CP}$	—	ns	
CLK $\uparrow$ →CLK $\downarrow$	$t_{CHCL}$	CLK	$V_{CC} = 3.0\text{ V}$ to $3.6\text{ V}$	$t_{CP}/2 - 15$	$t_{CP}/2 + 15$	ns	At $f_{CP} = 24\text{ MHz}$
				$t_{CP}/2 - 20$	$t_{CP}/2 + 20$	ns	At $f_{CP} = 12\text{ MHz}$
				$t_{CP}/2 - 64$	$t_{CP}/2 + 64$	ns	At $f_{CP} = 6\text{ MHz}$

Note :  $t_{CP}$  : See “(1) Clock input timing”.

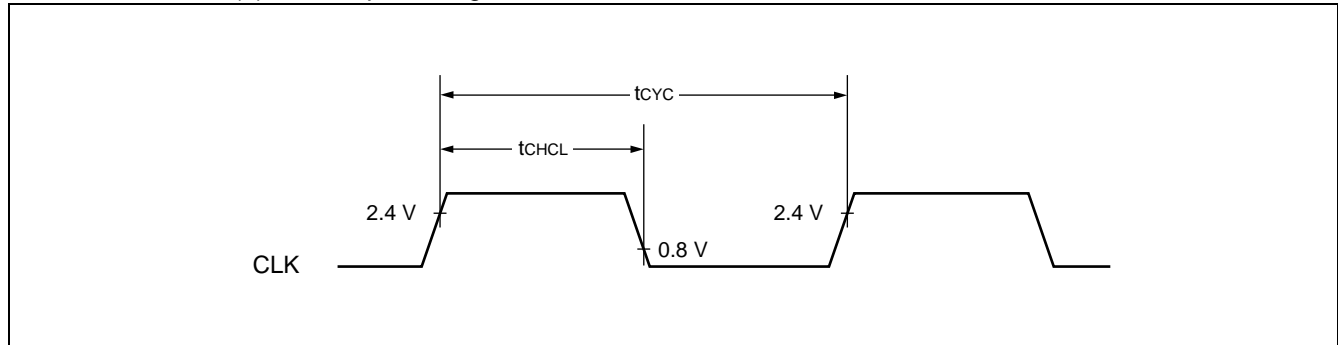



## (3) Reset

( $V_{CC} = AV_{CC} = 3.3 \text{ V} \pm 0.3 \text{ V}$ ,  $V_{SS} = AV_{SS} = 0.0 \text{ V}$ ,  $T_A = -40 \text{ }^\circ\text{C}$  to  $+85 \text{ }^\circ\text{C}$ )

Parameter	Symbol	Pin name	Conditions	Value		Unit	Remarks
				Min	Max		
Reset input time	$t_{RSTL}$	$\overline{RST}$	—	500	—	ns	At normal operating, At time base timer mode, At main sleep mode, At PLL sleep mode
				Oscillation time of oscillator* + 500 ns	—	$\mu\text{s}$	At stop mode, At sub clock mode, At sub sleep mode, At watch mode

\* : Oscillation time of oscillator is the time that the amplitude reaches 90 %. It takes several milliseconds to several dozens of milliseconds on a crystal oscillator, several hundreds of microseconds to several milliseconds on a FAR/ceramic oscillator, and 0 milliseconds on an external clock.

- During normal operation, time-base timer mode, main sleep mode and PLL sleep mode

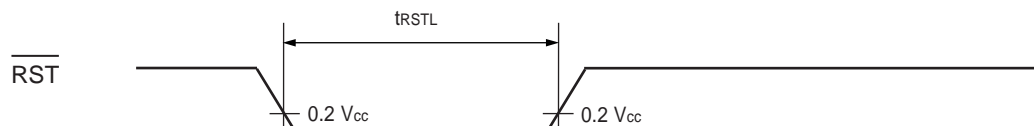

- During stop mode, subclock mode, sub-sleep mode and watch mode

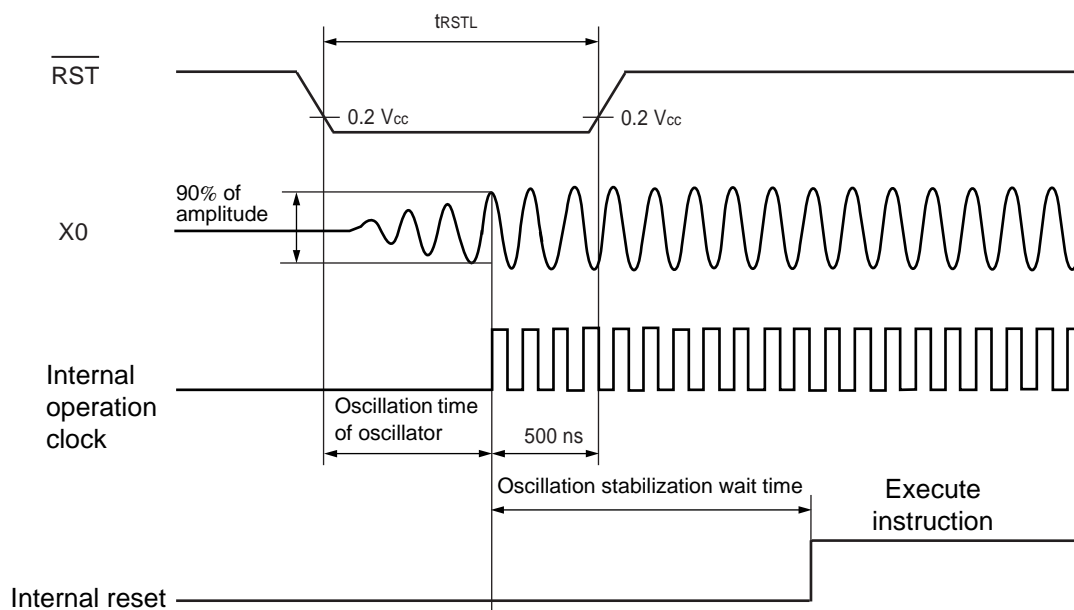

# MB90330 Series

## (4) Power-on reset

( $V_{CC} = AV_{CC} = 3.3 \text{ V} \pm 0.3 \text{ V}$ ,  $V_{SS} = AV_{SS} = 0.0 \text{ V}$ ,  $T_A = -40 \text{ }^\circ\text{C}$  to  $+85 \text{ }^\circ\text{C}$ )

Parameter	Symbol	Pin name	Condi- tions	Value		Unit	Remarks
				Min	Max		
Power supply rising time	$t_R$	$V_{CC}$	—	—	30	ms	
Power supply shutdown time	$t_{OFF}$	$V_{CC}$	—	1	—	ms	For repeated operation

- Notes :
- $V_{CC}$  must be lower than 0.2 V before the power supply is turned on.
  - The above standard is a value for performing a power-on reset.
  - In the device, there are internal registers which is initialized only by a power-on reset.  
When the initialization of these items is expected, turn on the power supply according to the standards.

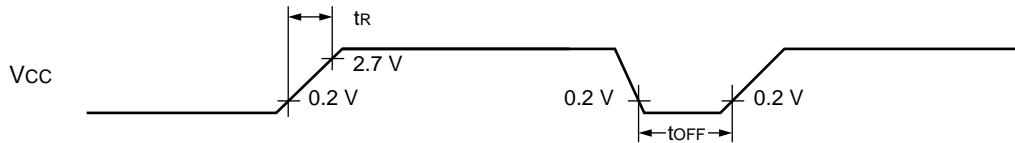

Sudden change of power supply voltage may activate the power-on reset function. When changing the power supply voltage during operation as illustrated below, voltage fluctuation should be minimized so that the voltage rises as smoothly as possible. When raising the power, do not use PLL clock. However, if voltage drop is 1 V/s or less, use of PLL clock is allowed during operation.

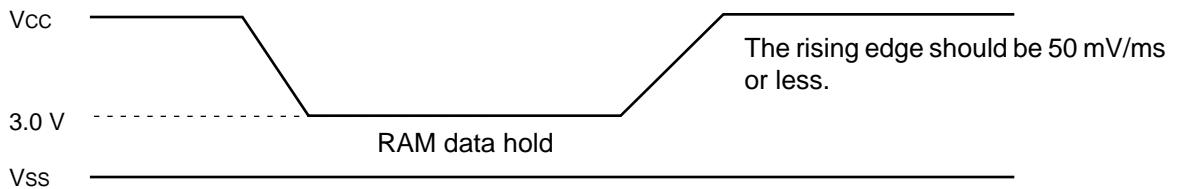

## (5) UART0, 1, 2, 3 I/O extended serial timing

( $V_{CC} = AV_{CC} = 3.3\text{ V} \pm 0.3\text{ V}$ ,  $V_{SS} = AV_{SS} = 0.0\text{ V}$ ,  $T_A = -40\text{ }^\circ\text{C}$  to  $+85\text{ }^\circ\text{C}$ )

Parameter	Symbol	Pin name	Conditions	Value		Unit	Remarks
				Min	Max		
Serial clock cycle time	$t_{SCYC}$	SCKx	Internal shift clock mode output pin is : $C_L = 80\text{ pF} + 1\text{TTL}$	8 $t_{CP}$	—	ns	
SCK↓→SOT delay time	$t_{SLOV}$	SCKx, SOTx		- 80	+ 80	ns	
Valid SIN→SCK↑	$t_{VSH}$	SCKx, SINx		100	—	ns	
SCK↑→valid SIN hold time	$t_{SHIX}$	SCKx, SINx		60	—	ns	
Serial clock H pulse width	$t_{SHSL}$	SCKx, SINx	External shift clock mode output pin is : $C_L = 80\text{ pF} + 1\text{TTL}$	4 $t_{CP}$	—	ns	
Serial clock L pulse width	$t_{LSLH}$	SCKx, SINx		4 $t_{CP}$	—	ns	
SCK↓→SOT delay time	$t_{SLOV}$	SCKx, SOTx		—	150	ns	
Valid SIN→SCK↑	$t_{VSH}$	SCKx, SINx		60	—	ns	
SCK↑→valid SIN hold time	$t_{SHIX}$	SCKx, SINx	60	—	ns		

- Notes :
- Above rating is the case of CLK synchronous mode.
  - $C_L$  is a load capacitance value on pins for testing.
  - $t_{CP}$  : See “ (1) Clock input timing”.

# MB90330 Series

- Internal shift clock mode

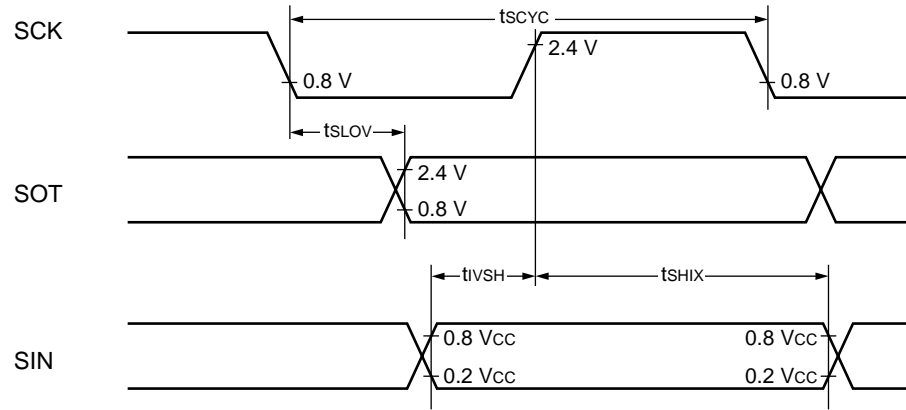

- External shift clock mode

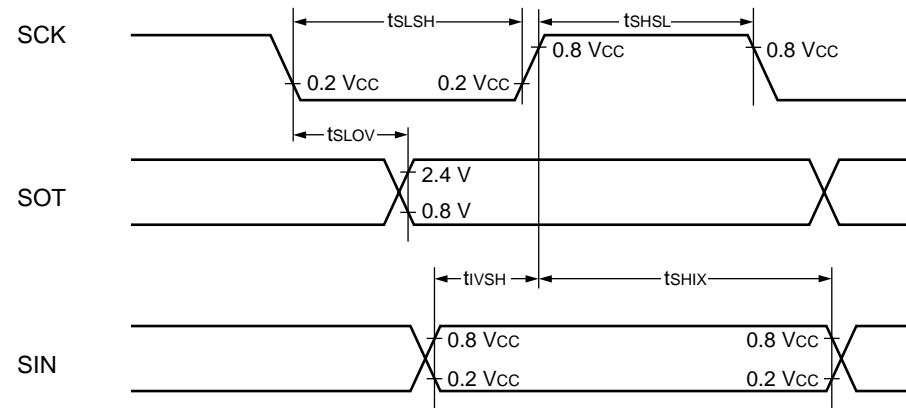

## (6) I<sup>2</sup>C timing

(V<sub>CC</sub> = AV<sub>CC</sub> = 3.3 V ± 0.3 V, V<sub>SS</sub> = AV<sub>SS</sub> = 0.0 V, T<sub>A</sub> = - 40 °C to + 85 °C)

Parameter	Symbol	Conditions	Value		Unit
			Min	Max	
SCL clock frequency	t <sub>SCL</sub>		0	100	kHz
(Repeat) [start] condition hold time SDA ↓ → SCL ↓	t <sub>HDSTA</sub>	Power-supply voltage of external pull-up resistor at 5.0 V.	4.0	—	μs
SCL clock "L" width	t <sub>LOW</sub>	R = 1.2 kΩ, C = 50 pF*2	4.7	—	μs
SCL clock "H" width	t <sub>HIGH</sub>	Power-supply voltage of external pull-up resistor at 3.6 V.	4.0	—	μs
Repeat [start] condition setup time SCL ↑ → SDA ↓	t <sub>SUSTA</sub>	R = 1.0 kΩ, C = 50 pF*2	4.7	—	μs
Data hold time SCL ↓ → SDA ↓ ↑	t <sub>HDDAT</sub>		0	3.45*3	μs
Data setup time SDA ↓ ↑ → SCL ↑	t <sub>SUDAT</sub>	Power-supply voltage of external pull-up resistor at 5.0 V. f <sub>CP</sub> *1 ≤ 20 MHz, R = 1.2 kΩ, C = 50 pF*2 Power-supply voltage of external pull-up resistor at 3.6 V. f <sub>CP</sub> *1 ≤ 20 MHz, R = 1.0 kΩ, C = 50 pF*2	250	—	ns
		Power-supply voltage of external pull-up resistor at 5.0 V. f <sub>CP</sub> *1 > 20 MHz, R = 1.2 kΩ, C = 50 pF*2 Power-supply voltage of external pull-up resistor at 3.6 V. f <sub>CP</sub> *1 > 20 MHz, R = 1.0 kΩ, C = 50 pF*2	200	—	
[Stop] condition setup time SCL ↑ → SDA ↑	t <sub>SUSTO</sub>	Power-supply voltage of external pull-up resistor at 5.0 V. R = 1.2 kΩ, C = 50 pF*2	4.0	—	μs
Bus free time between [stop] condition and [start] condition	t <sub>BUS</sub>	Power-supply voltage of external pull-up resistor at 3.6 V. R = 1.0 kΩ, C = 50 pF*2	4.7	—	μs

\*1 : f<sub>CP</sub> is internal operating clock frequency. See “ (1) Clock input timing”.

\*2 : R and C are pull-up resistance of SCL and SDA lines and load capacitance.

\*3 : The maximum t<sub>HDDAT</sub> only has to be met if the device does not stretch the “L” width (t<sub>LOW</sub>) of the SCL signal.

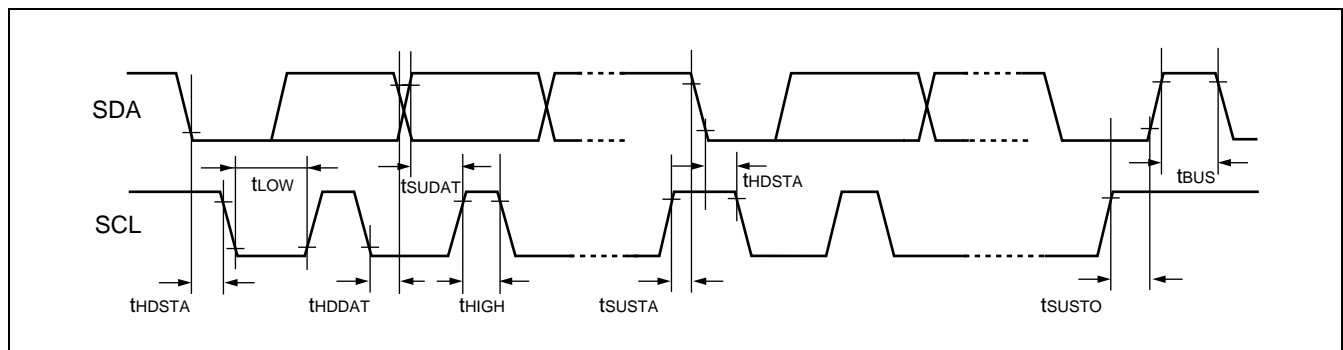

# MB90330 Series

## (7) Timer input timing

( $V_{CC} = AV_{CC} = 3.3\text{ V} \pm 0.3\text{ V}$ ,  $V_{SS} = AV_{SS} = 0.0\text{ V}$ ,  $T_A = -40\text{ }^\circ\text{C}$  to  $+85\text{ }^\circ\text{C}$ )

Parameter	Symbol	Pin name	Conditions	Value		Unit	Remarks
				Min	Max		
Input pulse width	$t_{TIWH}$ $t_{TIWL}$	FRCK, INx, TINx PWC	—	$4 t_{CP}$	—	ns	

Note :  $t_{CP}$  : See “ (1) Clock input timing”.

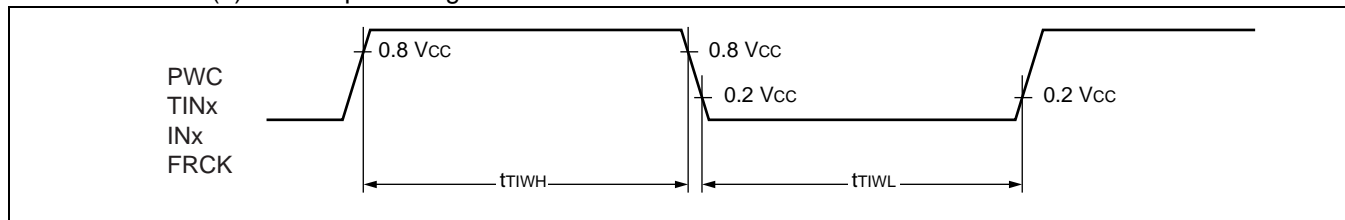

## (8) Timer output timing

( $V_{CC} = AV_{CC} = 3.3\text{ V} \pm 0.3\text{ V}$ ,  $V_{SS} = AV_{SS} = 0.0\text{ V}$ ,  $T_A = -40\text{ }^\circ\text{C}$  to  $+85\text{ }^\circ\text{C}$ )

Parameter	Symbol	Pin name	Conditions	Value		Unit	Remarks
				Min	Max		
CLK $\uparrow$ →T <sub>OUT</sub> change time PPG0 to PPG5 change time OUT0 to OUT3 change time	$t_{TO}$	TOTx, PPGx, OUTx	—	30	—	ns	

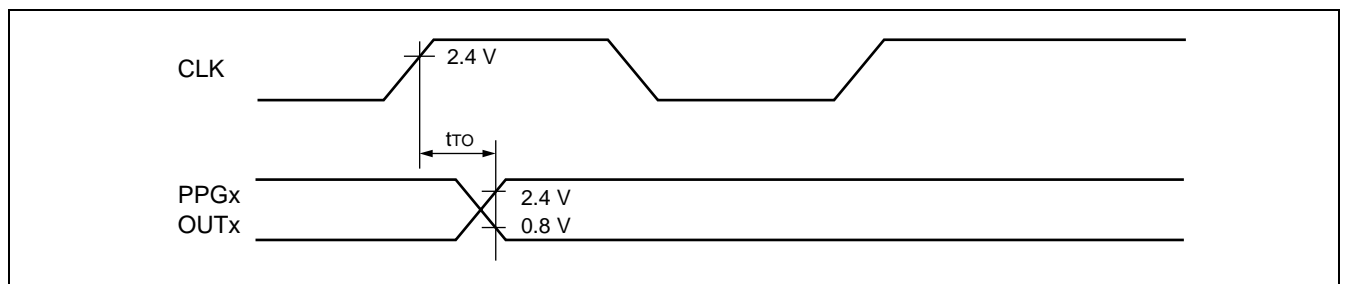

## (9) Trigger input timing

( $V_{CC} = AV_{CC} = 3.3\text{ V} \pm 0.3\text{ V}$ ,  $V_{SS} = AV_{SS} = 0.0\text{ V}$ ,  $T_A = -40\text{ }^\circ\text{C}$  to  $+85\text{ }^\circ\text{C}$ )

Parameter	Symbol	Pin name	Conditions	Value		Unit	Remarks
				Min	Max		
Input pulse width	$t_{TRGH}$	INTx, ADTG	—	$5 t_{CP}$	—	ns	At normal operating
	$t_{TRGL}$			1	—	$\mu\text{s}$	In Stop mode

Note :  $t_{CP}$  : See “ (1) Clock input timing”.

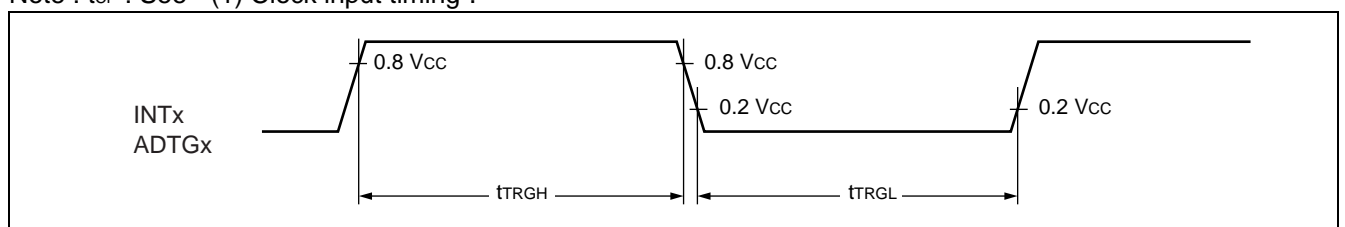

## (10) Bus read timing

( $V_{CC} = AV_{CC} = 3.3 V \pm 0.3 V$ ,  $V_{SS} = AV_{SS} = 0.0 V$ ,  $T_A = 0\text{ }^{\circ}\text{C to } +70\text{ }^{\circ}\text{C}$ )

Parameter	Sym bol	Pin name	Condi- tions	Value		Unit	Remarks
				Min	Max		
ALE pulse width	$t_{LHLL}$	ALE	—	$t_{CP}/2 - 15$	—	ns	At $f_{CP} = 24\text{ MHz}$
				$t_{CP}/2 - 20$	—	ns	At $f_{CP} = 12\text{ MHz}$
				$t_{CP}/2 - 35$	—	ns	At $f_{CP} = 6\text{ MHz}$
Valid address→ALE↓time	$t_{AVLL}$	Address, ALE	—	$t_{CP}/2 - 17$	—	ns	
				$t_{CP}/2 - 40$	—	ns	At $f_{CP} = 6\text{ MHz}$
ALE↓→Address valid time	$t_{LLAX}$	ALE, Address	—	$t_{CP}/2 - 12$	—	ns	
Valid address→ $\overline{RD}$ ↓time	$t_{AVRL}$	$\overline{RD}$ , Address	—	$t_{CP} - 25$	—	ns	
Valid address→valid data input	$t_{AVDV}$	Address/ data	—	—	$5 t_{CP}/2 - 55$	ns	
				—	$5 t_{CP}/2 - 80$	ns	At $f_{CP} = 6\text{ MHz}$
$\overline{RD}$ pulse width	$t_{RLRH}$	$\overline{RD}$	—	$3 t_{CP}/2 - 25$	—	ns	At $f_{CP} = 24\text{ MHz}$
				$3 t_{CP}/2 - 20$	—	ns	At $f_{CP} = 12\text{ MHz}$
$\overline{RD}$ ↓→valid data input	$t_{RLDV}$	$\overline{RD}$ , Data	—	—	$3 t_{CP}/2 - 55$	ns	
				—	$3 t_{CP}/2 - 80$	ns	At $f_{CP} = 6\text{ MHz}$
$\overline{RD}$ ↓→data hold time	$t_{RHDX}$	$\overline{RD}$ , Data	—	0	—	ns	
$\overline{RD}$ ↑→ALE↑time	$t_{RHLH}$	$\overline{RD}$ , ALE	—	$t_{CP}/2 - 15$	—	ns	
$\overline{RD}$ ↑→address valid time	$t_{RHAX}$	Address, $\overline{RD}$	—	$t_{CP}/2 - 10$	—	ns	
Valid address→CLK↑time	$t_{AVCH}$	Address, CLK	—	$t_{CP}/2 - 17$	—	ns	
$\overline{RD}$ ↓→CLK↑time	$t_{RLCH}$	$\overline{RD}$ , CLK	—	$t_{CP}/2 - 17$	—	ns	
ALE↓→ $\overline{RD}$ ↓time	$t_{LLRL}$	$\overline{RD}$ , ALE	—	$t_{CP}/2 - 15$	—	ns	

Note :  $t_{CP}$  : See “ (1) Clock input timing”.

# MB90330 Series

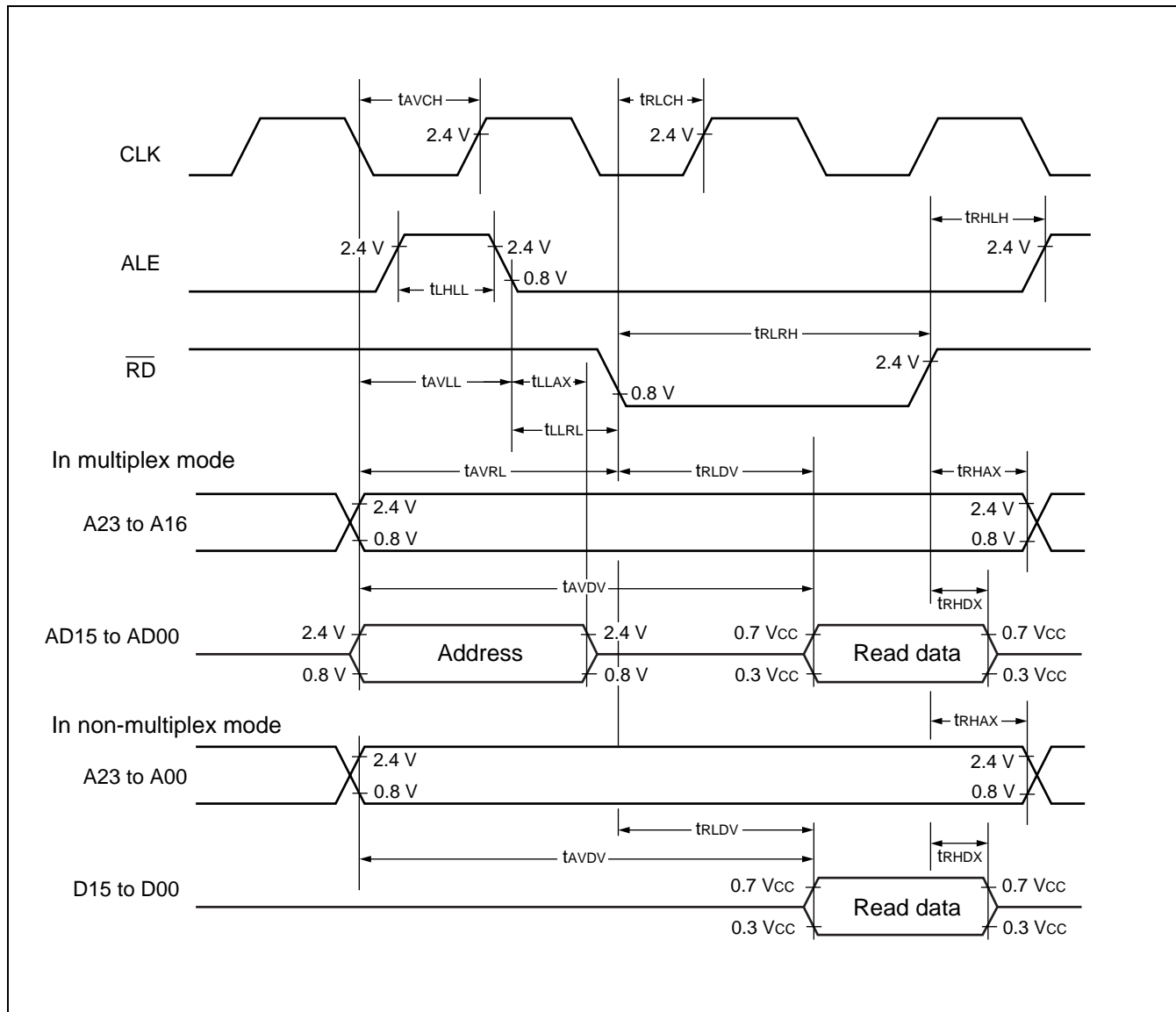



## (11) Bus write timing

( $V_{CC} = AV_{CC} = 3.3\text{ V} \pm 0.3\text{ V}$ ,  $V_{SS} = AV_{SS} = 0.0\text{ V}$ ,  $T_A = 0\text{ }^\circ\text{C}$  to  $+70\text{ }^\circ\text{C}$ )

Parameter	Symbol	Pin name	Conditions	Value		Unit	Remarks
				Min	Max		
Valid address $\rightarrow \overline{WR} \downarrow$ time	$t_{AVWL}$	Address, $\overline{WR}$	—	$t_{CP} - 15$	—	ns	
$\overline{WR}$ pulse width	$t_{WLWH}$	$\overline{WRL}$ , $\overline{WRH}$	—	$3 t_{CP}/2 - 25$	—	ns	At $f_{cp} = 24\text{ MHz}$
			—	$3 t_{CP}/2 - 20$	—	ns	At $f_{cp} = 12\text{ MHz}$
Valid data output $\rightarrow \overline{WR} \uparrow$ time	$t_{DVWH}$	Data, $\overline{WR}$	—	$3 t_{CP}/2 - 15$	—	ns	
$\overline{WR} \uparrow \rightarrow$ data hold time	$t_{WHDX}$	$\overline{WR}$ , Data	—	10	—	ns	At $f_{cp} = 24\text{ MHz}$
			—	20	—	ns	At $f_{cp} = 12\text{ MHz}$
			—	30	—	ns	At $f_{cp} = 6\text{ MHz}$
$\overline{WR} \uparrow \rightarrow$ address valid time	$t_{WHAX}$	$\overline{WR}$ , Address	—	$t_{CP}/2 - 10$	—	ns	
$\overline{WR} \uparrow \rightarrow$ ALE $\uparrow$ time	$t_{WHLH}$	$\overline{WR}$ , ALE	—	$t_{CP}/2 - 15$	—	ns	
$\overline{WR} \downarrow \rightarrow$ CLK $\uparrow$ time	$t_{WLCH}$	$\overline{WR}$ , CLK	—	$t_{CP}/2 - 17$	—	ns	

Note :  $t_{CP}$  : See “ (1) Clock input timing”.

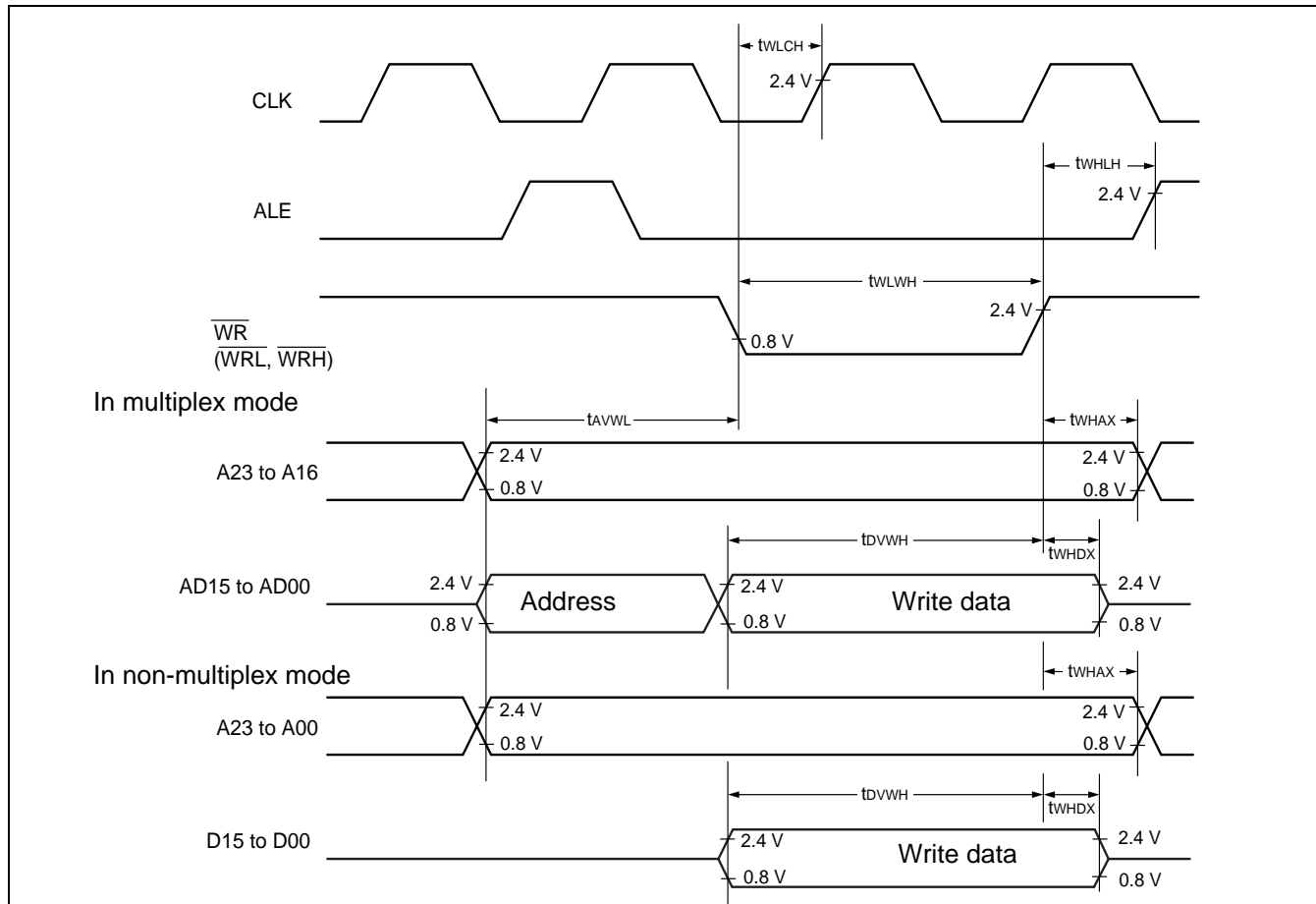

# MB90330 Series

## (12) Ready input timing

( $V_{CC} = AV_{CC} = 3.3\text{ V} \pm 0.3\text{ V}$ ,  $V_{SS} = AV_{SS} = 0.0\text{ V}$ ,  $T_A = 0\text{ }^\circ\text{C}$  to  $+70\text{ }^\circ\text{C}$ )

Parameter	Symbol	Pin name	Conditions	Value		Unit	Remarks
				Min	Max		
RDY set-up time	$t_{RYHS}$	RDY	—	35	—	ns	$f_{cp} = 6\text{ MHz}$
			—	70	—	ns	
RDY hold time	$t_{RYHH}$		—	0	—	ns	

- Notes :
- If the RDY set-up time is insufficient, use the auto-ready function.
  - For input from the RDY pin, be careful as failure to satisfy AC standards may cause the chip to run out of control.

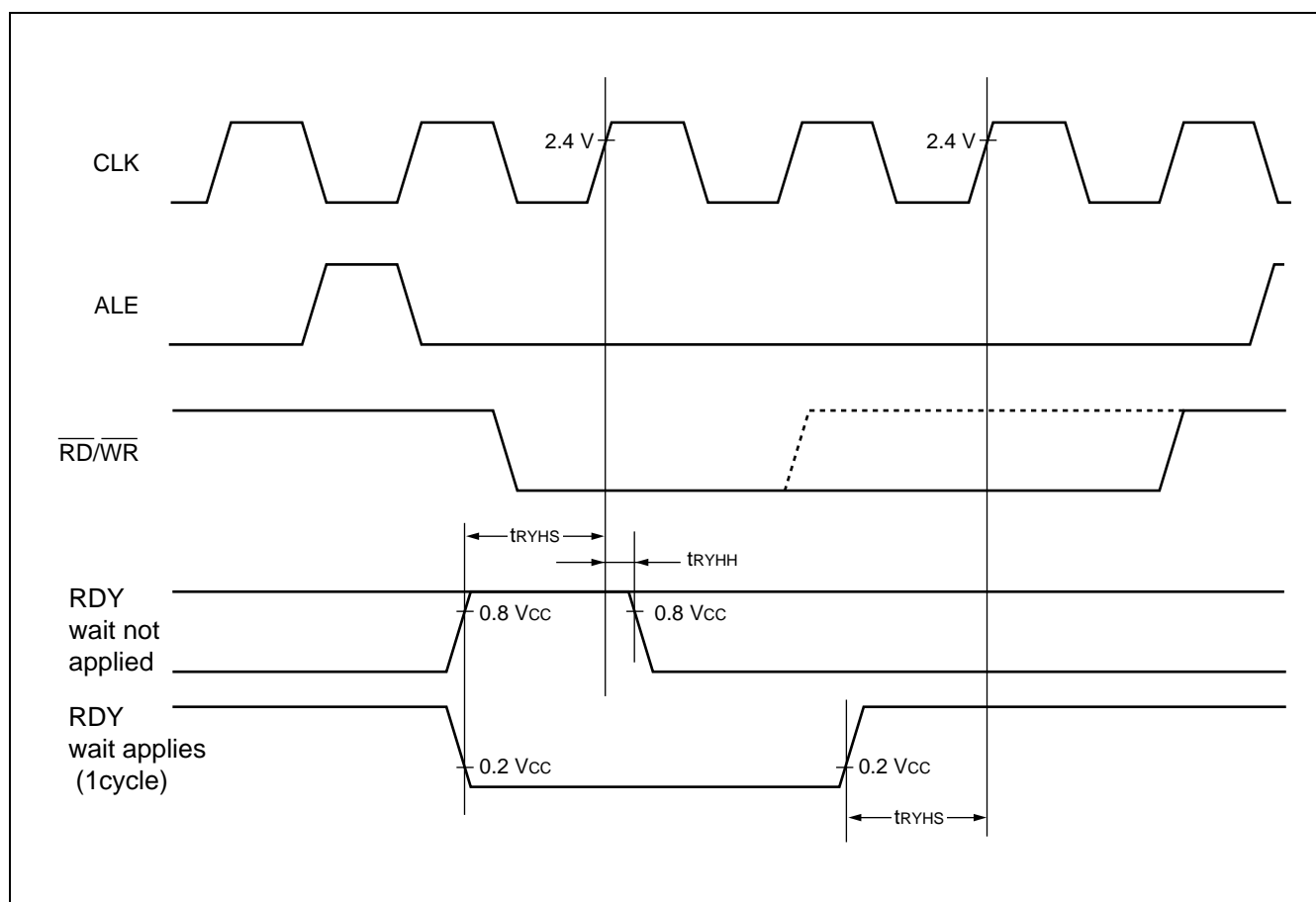

## (13) Hold timing

( $V_{CC} = AV_{CC} = 3.3 \text{ V} \pm 0.3 \text{ V}$ ,  $V_{SS} = AV_{SS} = 0.0 \text{ V}$ ,  $T_A = 0 \text{ }^\circ\text{C}$  to  $+70 \text{ }^\circ\text{C}$ )

Parameter	Symbol	Pin name	Condi- tions	Value		Unit	Remarks
				Min	Max		
Pin floating $\rightarrow$ $\overline{\text{HAK}} \downarrow$ time	$t_{\text{XHAL}}$	$\overline{\text{HAK}}$	—	30	$t_{\text{CP}}$	ns	
$\overline{\text{HAK}} \downarrow \rightarrow$ pin valid time	$t_{\text{HAHV}}$	$\overline{\text{HAK}}$		$t_{\text{CP}}$	$2 t_{\text{CP}}$	ns	

Notes : • It takes one cycle or more for  $\overline{\text{HAK}}$  to change after the HRQ pin is captured.  
 •  $t_{\text{CP}}$  : See “ (1) Clock input timing”.

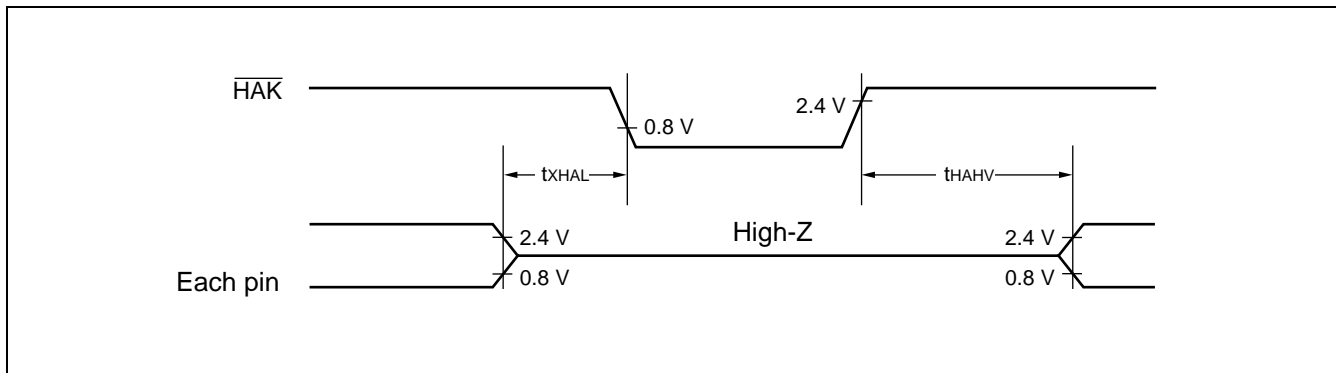

# MB90330 Series

## 5. Electrical Characteristics for the A/D Converter

( $V_{CC} = AV_{CC} = 3.3 \text{ V} \pm 0.3 \text{ V}$ ,  $V_{SS} = AV_{SS} = 0.0 \text{ V}$ ,  $T_A = -40 \text{ }^\circ\text{C}$  to  $+85 \text{ }^\circ\text{C}$ )

Parameter	Symbol	Pin name	Value			Unit	Remarks
			Min	Typ	Max		
Resolution	—	—	—	—	10	bit	
Total error	—	—	—	—	$\pm 3.0$	LSB	
Nonlinear error	—	—	—	—	$\pm 2.5$	LSB	
Differential linear error	—	—	—	—	$\pm 1.9$	LSB	
Zero transition voltage	$V_{OT}$	AN0 to AN15	$AV_{SS} - 1.5 \text{ LSB}$	$AV_{SS} + 0.5 \text{ LSB}$	$AV_{SS} + 2.5 \text{ LSB}$	mV	1 LSB = AVRH/1024
Full-scale transition voltage	$V_{FST}$	AN0 to AN15	$AVRH - 3.5 \text{ LSB}$	$AVRH - 1.5 \text{ LSB}$	$AVRH + 0.5 \text{ LSB}$	mV	
Conversion time	—	—	—	$176 t_{CP}^{*1}$	—	ns	
Sampling time	—	—	—	$64 t_{CP}^{*1}$	—	ns	
Analog port input current	$I_{AIN}$	AN0 to AN15	—	—	10	$\mu\text{A}$	
Analog input voltage	$V_{AIN}$	AN0 to AN15	0	—	AVRH	V	
Reference voltage	—	AVRH	2.7	—	$AV_{CC}$	V	
Power supply current	$I_A$	$AV_{CC}$	—	1.4	3.5	mA	
	$I_{AH}$	$AV_{CC}$	—	—	5	$\mu\text{A}$	*2
Reference voltage supplying current	$I_R$	AVRH	—	95	170	$\mu\text{A}$	
	$I_{RH}$	AVRH	—	—	5	$\mu\text{A}$	*2
Interchannel disparity	—	AN0 to AN15	—	—	4	LSB	

\*1 :  $t_{CP}$  : See “ (1) Clock input timing”.

\*2 : The current when the CPU is in stop mode and the A/D converter is not operating (For  $V_{CC} = AV_{CC} = AVRH = 3.3 \text{ V}$ ).

Notes :

• **About the external impedance of the analog input and its sampling time**

- A/D converter with sample and hold circuit. If the external impedance is too high to keep sufficient sampling time, the analog voltage charged to the internal sample and hold capacitor is insufficient, adversely affecting A/D conversion precision.

• Analog input circuit model

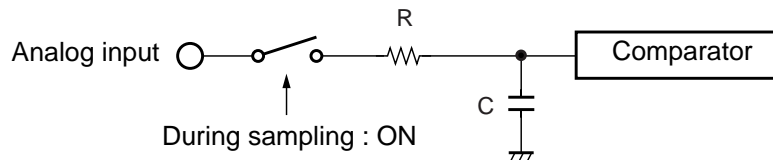

	R	C
MB90333A	1.9 kΩ (Max)	32.3 pF (Max)
MB90F334A	1.9 kΩ (Max)	25.0 pF (Max)
MB90V330A	1.9 kΩ (Max)	32.3 pF (Max)

Note : The values are reference values.

- To satisfy the A/D conversion precision standard, consider the relationship between the external impedance and minimum sampling time and either adjust the resistor value and operating frequency or decrease the external impedance so that the sampling time is longer than the minimum value.

• The relationship between the external impedance and minimum sampling time

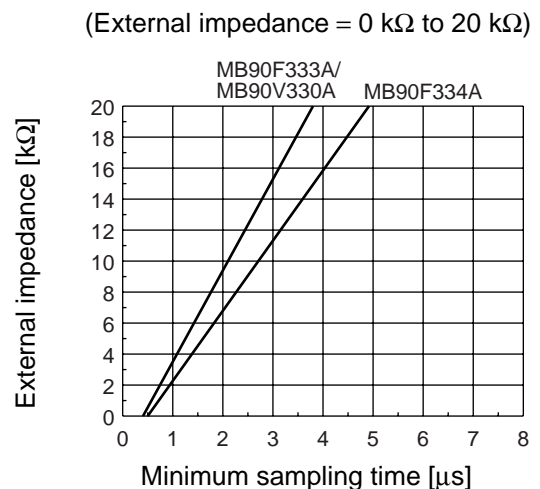
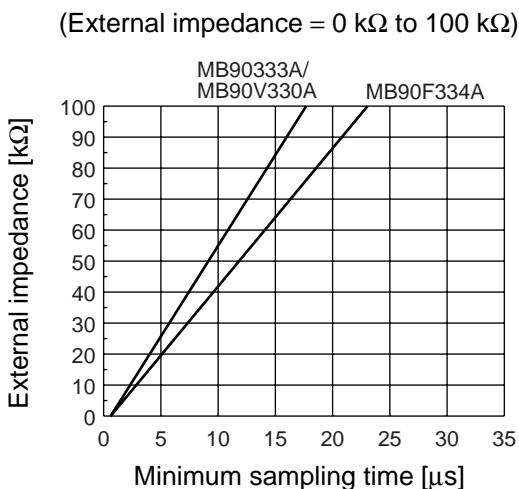

- If the sampling time cannot be sufficient, connect a capacitor of about 0.1 μF to the analog input pin.

• **About errors**

As  $|AVRH|$  becomes smaller, values of relative errors grow larger.

# MB90330 Series

## 6. USB characteristics

( $V_{CC} = AV_{CC} = 3.3 \text{ V} \pm 0.3 \text{ V}$ ,  $V_{SS} = AV_{SS} = 0.0 \text{ V}$ ,  $T_A = 0 \text{ }^\circ\text{C}$  to  $+70 \text{ }^\circ\text{C}$ )

Parameter	Symbol	Value		Unit	Remarks	
		Min	Max			
Input characteristics	Input High level voltage	$V_{IH}$	2.0	—	V	
	Input Low level voltage	$V_{IL}$	—	0.8	V	
	Differential input sensitivity	$V_{DI}$	0.2	—	V	
	Differential common mode range	$V_{CM}$	0.8	2.5	V	
Output characteristics	Output High level voltage	$V_{OH}$	2.8	3.6	V	$I_{OH} = -200 \mu\text{A}$
	Output Low level voltage	$V_{OL}$	0.0	0.3	V	$I_{OL} = 2 \text{ mA}$
	Cross over voltage	$V_{CRS}$	1.3	2.0	V	
	Rise time	$t_{FR}$	4	20	ns	Full Speed
		$t_{LR}$	75	300	ns	Low Speed
	Fall time	$t_{FF}$	4	20	ns	Full Speed
		$t_{LF}$	75	300	ns	Low Speed
	Rising/falling time matching	$t_{RFM}$	90	111.11	%	$(T_{FR}/T_{FF})$
$t_{RLM}$		80	125	%	$(T_{LR}/T_{LF})$	
Output resistance	$Z_{DRV}$	28	44	$\Omega$	Including $R_s = 27 \Omega$	

### • Data signal timing (Full Speed)

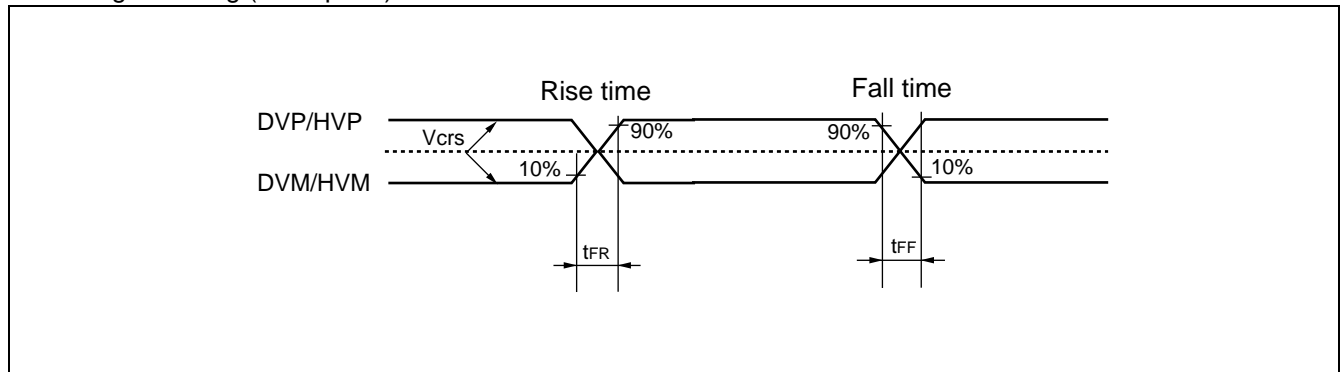

### • Data signal timing (Low Speed)

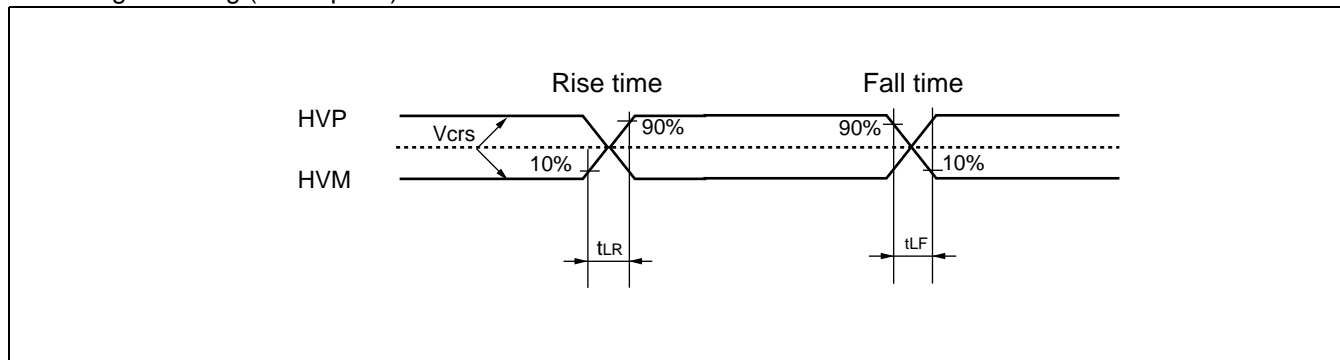

- Load condition (Full Speed)

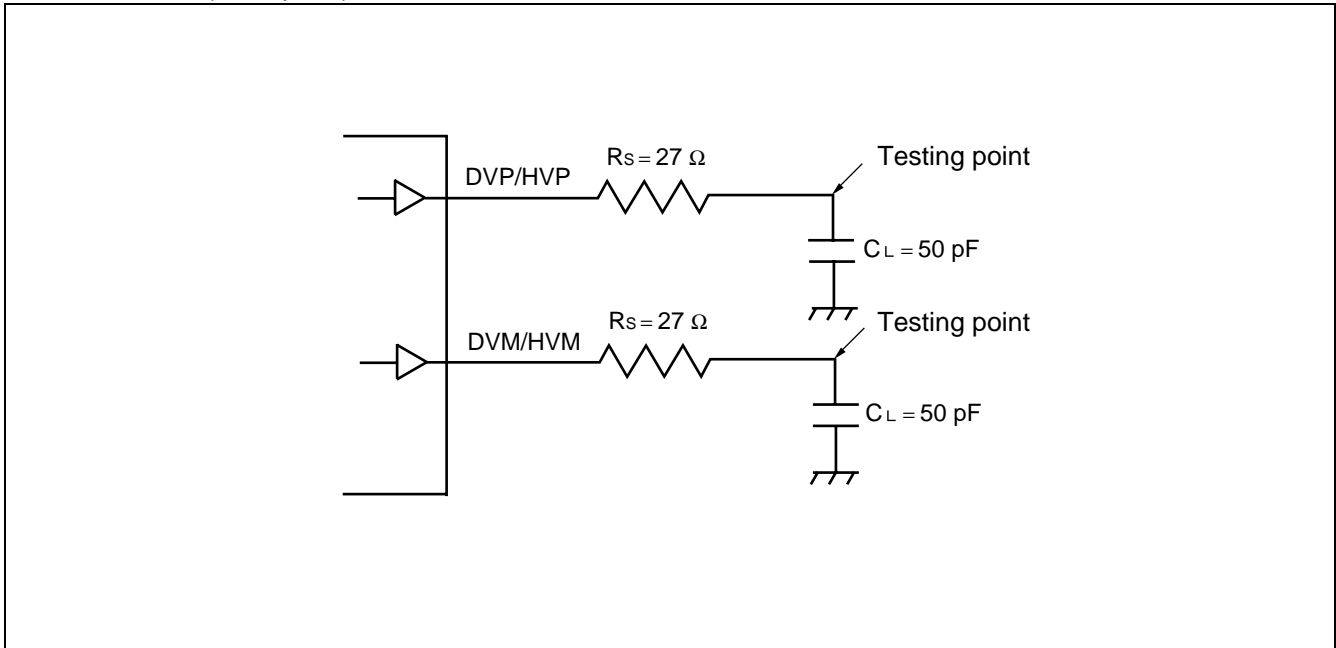

- Load condition (Low Speed)

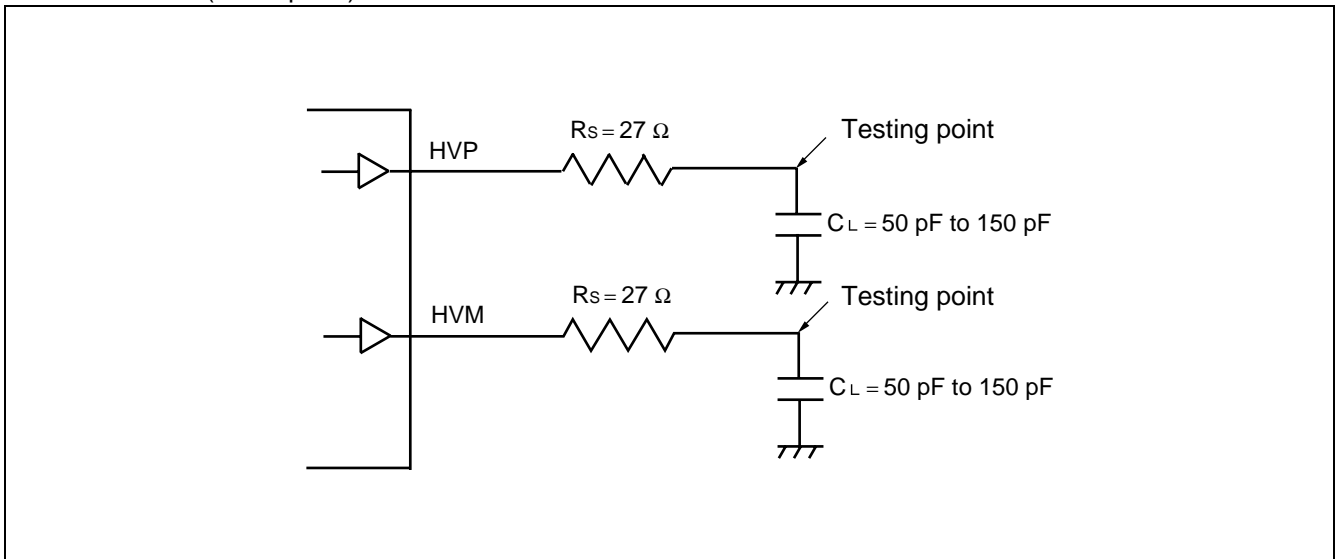

# MB90330 Series

## 7. Flash memory write/erase characteristics

Parameter	Condition	Value			Unit	Remarks
		Min	Typ	Max		
Sector erase time	T <sub>A</sub> = + 25 °C V <sub>CC</sub> = 3.0 V	—	1	15	s	Excludes 00 <sub>H</sub> programming prior to erasure.
Chip erase time		—	9	—	s	Excludes 00 <sub>H</sub> programming prior to erasure.
Word (16-bit width) programming time		—	16	3,600	μs	Except for over head time of system level
Programming/erase cycle	—	10,000	—	—	cycle	
Flash memory data retaining period	Average T <sub>A</sub> = + 85 °C	20	—	—	year	*

\* : This value comes from the technology qualification. (using Arrhenius equation to translate high temperature measurements into normalized value at + 85 °C)



## ■ ORDERING INFORMATION

Part number	Package	Remarks
MB90F334APFF MB90333APFF	120-pin Plastic LQFP (FPT-120P-M05)	
MB90F334APMC MB90333APMC	120-pin Plastic LQFP (FPT-120P-M21)	
MB90V330A	299-pin Ceramic PGA (PGA-299C-A01)	For evaluation

# MB90330 Series

## ■ PACKAGE DIMENSIONS

120-pin Plastic LQFP  
(FPT-120P-M05)

Note 1) \* : These dimensions do not include resin protrusion.  
 Note 2) Pins width and pins thickness include plating thickness.  
 Note 3) Pins width do not include tie bar cutting remainder.

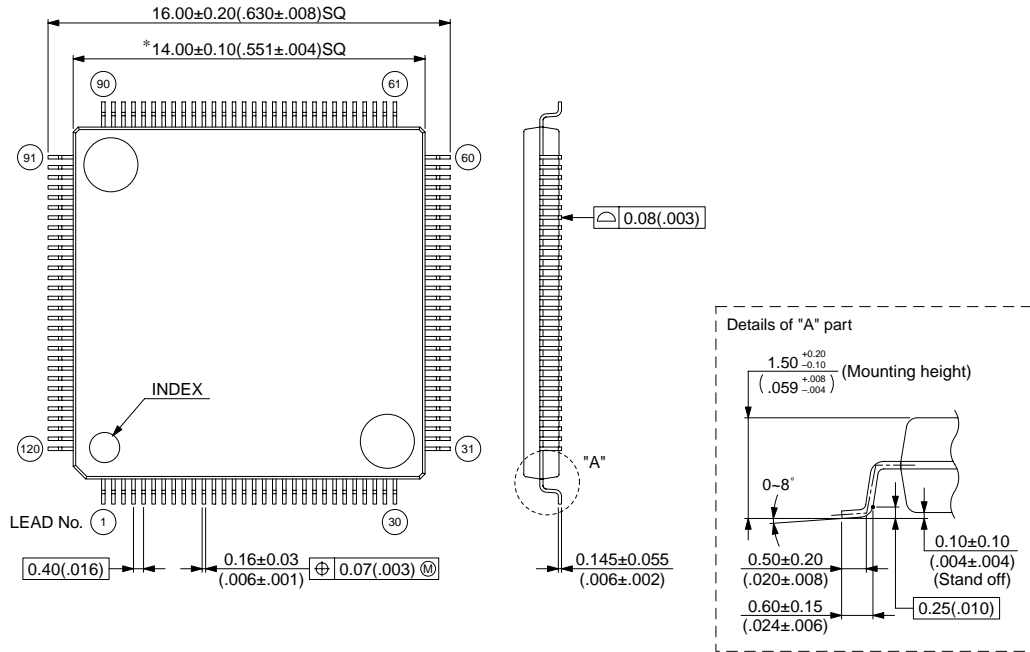

© 2003 FUJITSU LIMITED F120006S-c-4-5

Dimensions in mm (inches)

Note : The values in parentheses are reference values.

(Continued)

(Continued)

120-pin Plastic LQFP  
(FPT-120P-M21)

- Note 1) \* : These dimensions do not include resin protrusion.  
Resin protrusion is +0.26 (.010) MAX (each side) .  
Note 2) Pins width and pins thickness include plating thickness.  
Note 3) Pins width do not include tie bar cutting remainder.

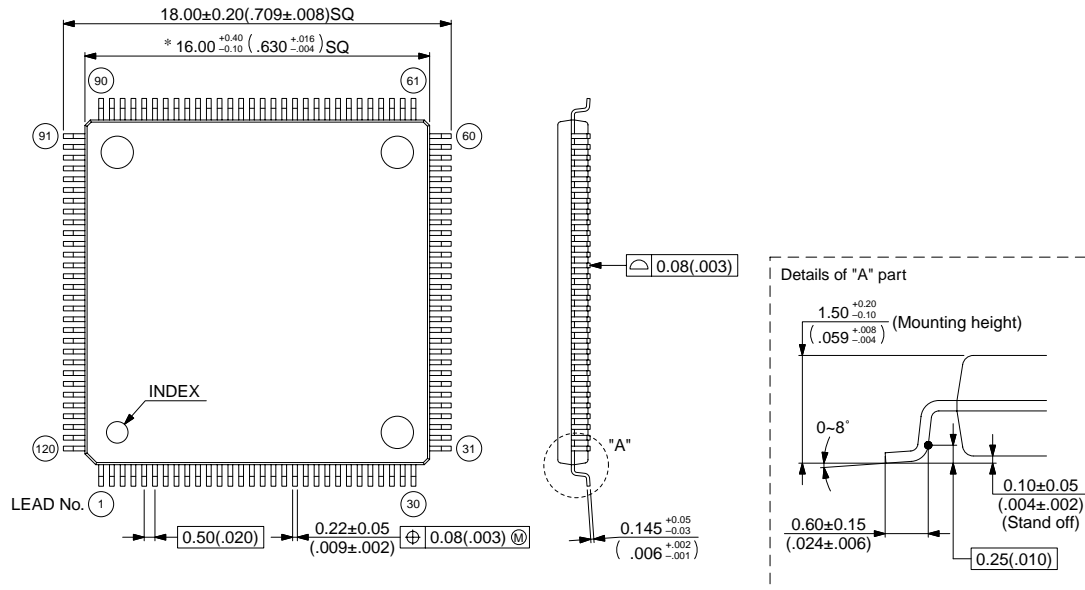

© 2002 FUJITSU LIMITED F120033S-c-4-4

Dimensions in mm (inches)

Note : The values in parentheses are reference values.

## FUJITSU LIMITED

All Rights Reserved.

The contents of this document are subject to change without notice. Customers are advised to consult with FUJITSU sales representatives before ordering.

The information, such as descriptions of function and application circuit examples, in this document are presented solely for the purpose of reference to show examples of operations and uses of Fujitsu semiconductor device; Fujitsu does not warrant proper operation of the device with respect to use based on such information. When you develop equipment incorporating the device based on such information, you must assume any responsibility arising out of such use of the information. Fujitsu assumes no liability for any damages whatsoever arising out of the use of the information.

Any information in this document, including descriptions of function and schematic diagrams, shall not be construed as license of the use or exercise of any intellectual property right, such as patent right or copyright, or any other right of Fujitsu or any third party or does Fujitsu warrant non-infringement of any third-party's intellectual property right or other right by using such information. Fujitsu assumes no liability for any infringement of the intellectual property rights or other rights of third parties which would result from the use of information contained herein.

The products described in this document are designed, developed and manufactured as contemplated for general use, including without limitation, ordinary industrial use, general office use, personal use, and household use, but are not designed, developed and manufactured as contemplated (1) for use accompanying fatal risks or dangers that, unless extremely high safety is secured, could have a serious effect to the public, and could lead directly to death, personal injury, severe physical damage or other loss (i.e., nuclear reaction control in nuclear facility, aircraft flight control, air traffic control, mass transport control, medical life support system, missile launch control in weapon system), or (2) for use requiring extremely high reliability (i.e., submersible repeater and artificial satellite).

Please note that Fujitsu will not be liable against you and/or any third party for any claims or damages arising in connection with above-mentioned uses of the products.

Any semiconductor devices have an inherent chance of failure. You must protect against injury, damage or loss from such failures by incorporating safety design measures into your facility and equipment such as redundancy, fire protection, and prevention of over-current levels and other abnormal operating conditions.

If any products described in this document represent goods or technologies subject to certain restrictions on export under the Foreign Exchange and Foreign Trade Law of Japan, the prior authorization by Japanese government will be required for export of those products from Japan.