



LBT07061 MHz SAW Filter Electrical Characteristic

Specifications

Parameter	Unit	Minimum	Typical	Maximum
Center Frequency	MHz	69.9	70	70.1
Insertion Loss	dB		23.1	25
3 dB Bandwidth	MHz	4.6	4.7	4.8
21 dB Bandwidth			5.56	5.6
31 dB Bandwidth			5.76	5.9
40 dB Bandwidth	MHz		5.88	6.7
Passband variation	dB		0.7	1.0
Absolute Delay	usec		2.82	3.0
Group Delay Variation	nsec		50	150
Ultimate Rejection	dB	50	55	
Substrate Material		112 LT		
Ambient Temperature	°C	25		
Package Size		DIP3512 (35.0x12.7x5.2mm ³)		

Typical Performance

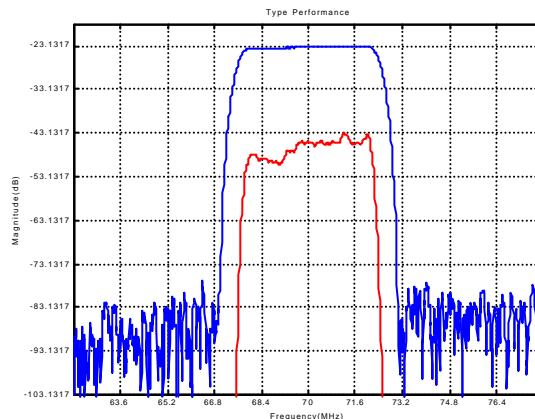

Package Outline

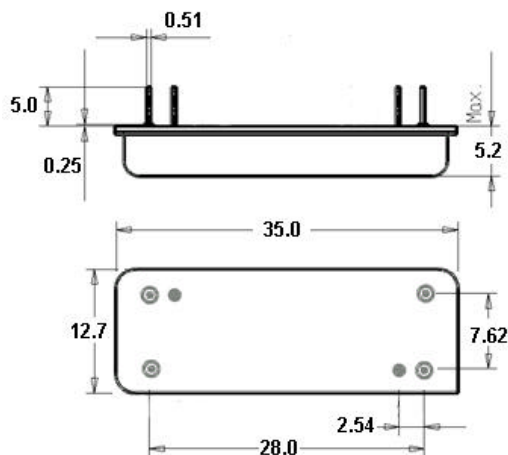

Matching Configuration

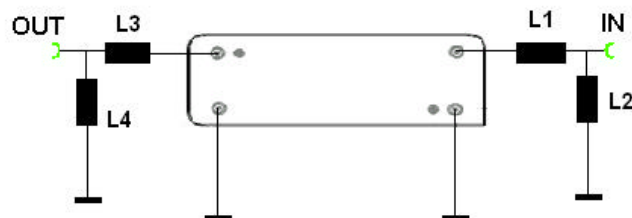

$$L1=L3=56\text{nH}$$

$$L2=L4=68\text{nH}$$

Source/Load Impedance = 50 ohm