

DATA SHEET

HT1 MOA3 S30

HITAGTM1 Chip Module

Preliminary Specification
Revision 1.1

August 1997



PHILIPS

Table of Contents

1 Definitions.....	3
1.1 Objective of the Specifications	3
1.2 Definition of the Chip Module	3
1.3 Use of the Modules	3
2 Specifications	4
2.1 Mechanical Properties	4
2.2 Materials	4
2.3 Temperature Range	4
2.4 Storage Conditions	5
2.5 Delivery Conditions	5
2.6 Electrical Specifications.....	6
3 Drawing of the Chip Module HT1 MOA3 S30.....	7
3.1 Drawing of the Reel.....	7
3.2 Module outline suggestion	8
3.3 Splicing Specification	9
4 Coil Specifications.....	10
5 Functional Description of HITAG 1	12
5.1 Memory Organization.....	12
5.2 Anticollision.....	13
5.3 Operation Modes and Configuration	14
5.3.1 Modes of Operation	14
5.3.2 Configuration.....	14
5.4 Configuration of Delivered HITAG 1 Transponders.....	17
5.5 Definition of Keys and Logdata	17
6 Quality Inspection	19
7 Characterisation and Test of the Final Transponder.....	20
7.1 Characterisation of the Transponder	20
7.2 Final Test of the Transponder	20
8 Ordering Information.....	21

HITAG™ is a trademark of Philips Electronics N.V.

1 Definitions

1.1 Objective of the Specifications

This specification lists the parameters to be fulfilled by the HITAG 1 chip module HT1 MOA3 S30 for contactless smart cards or similar transponders (as e.g. discs).

1.2 Definition of the Chip Module

A chip module is an electronically packaged chip covered with a globe top cap. The HT1 MOA3 S30 is above all used as card module, i.e. for further lamination into contactless smart cards according to ISO 10536.1.

So the HITAG 1 chip module HT1 MOA3 S30 is best suited for customers that do not want to spend time with micro assembly and therefore start - e.g. ISO card production - with the HITAG 1 chip module.

1.3 Use of the Modules

The HITAG 1 modules are designed to be connected to a coil and then to be further processed by packaging into a transponder (e.g. lamination into an ISO smart card). Specific processing information for the coil-module connection and packaging is given in the specification.

For production of contactless chip cards it is recommended to prepunch card foils to create a recess for the chip module in the card body.

2 Specifications

2.1 Mechanical Properties

Width (Proposed Punching Outline)	7.55 mm	see also drawing in chapter 3
Length (Proposed Punching Outline)	11.75 mm	
Overall Thickness	0.45 mm \pm 0.03 mm	
Film Thickness	0.16 mm \pm 0.005 mm	
Bondpad Size for Transponder Coil / Module Interconnection	1.9 x 3.5 mm	Suitable for Welding/Soldering/ Conductive Gluing

2.2 Materials

Tape	110 μ m	Glass epoxy
Copper Plating	35 μ m	ED copper
Bond Plating	Ni / Au	Suitable for Al and Au wire bonding
Backside Plating	Ni / Au	
Glob Top	Filled Epoxy	Thermal curing

2.3 Temperature Range

Operating	-25°C to +85°C	For packed transponder, depending on type of package
Processing	150°C for 30 minutes	at a standard lamination pressure for contactless smart card plastic materials (e.g. PVC, PET, ...)
Welding Parameters	max. 25 ms @ 500 °C	on bond pads
Soldering Parameters	max. 3 s @ 390 °C	on bond pads

2.4 Storage Conditions

Temperature	15 - 30 °C	
Relative Humidity	40 - 70 %	
Duration	1 year	

2.5 Delivery Conditions

Delivery Identification	Date of ready for shipment, reel numbers, total quantity of good modules with the detail of good modules per reel, order number, product type, no supplier identification on reels, bags and boxes.	
Types of Delivery	Chip modules on reel single chip modules (bulk goods)	approx. 15.000 to 20.000 pcs. per reel, tape width super 35 mm, pitch 9,5 mm, 2 rows 500 pcs . per bag
Packing and Transport	According to documentation "Packing Method Modules (reel)" "Packing Method Modules (singulated)"	Order-No. 3322 845 04881
Bad Module Marking	All bad modules (mechanical and electrical faults) must be punched by reject hole for customer Bad positions (reel): <20%	see drawings chapter 3
Splicing Specifications	Tape material: adhes. tape 15,5 +/- 0,7 mm, thermal resistance at <190°C by < 100 cN tractive power and < 30 sec. duration.	see drawings chapter 3
Labeling	Identification label on the reel and on carton bag: - Product type - Number of the reel - Total number of positions - Number of good positions - Date of sealing (to be checked) - Two batches per reel only - Batchnumber indication (only coded, to be checked)	

2.6 Electrical Specifications

	Symbol	min	typ	max	Comment / Conditions
Absolute Maximum Ratings					
Junction Temperature	T_J	-55°C		140°C	
Input Peak Current	I_{INpeak}			30 mA	
Latch up Current		100 mA			MIL-STD 883D, Method 3023
ESD		2 kV			MIL-STD 883D, Method 3015.7, Human Body
Operating Range					
Temperature	T_A	-40°C		85°C	$R_{ThJunctionAmbient} \leq 30 \text{ K/W} @ I_{INpeak} = 30 \text{ mA}$
Input Threshold Voltage ^{1) 3)}	$V_{IN,TH}$		3,1 V _p	4,2 V _p	start modulation after SETCC
Input Read Voltage ^{1) 3)}	$V_{IN,RD}$		3,5 V _p	4,5 V _p	read E ² PROM
Input Write Voltage ^{1) 3)}	$V_{IN,WR}$		3,7 V _p	4,7 V _p	write E ² PROM
Demodulator					
Range ³⁾	V_{DEM_R}	2,0 V _p		4,0 V _p	$V_{INHigh} - V_{INLow} @ V_{INHigh} = 5,0 \text{ V}_p$ $T_0=8 \mu\text{s}, T_{MOD}=6 \cdot T_0$ ²⁾
Modulator					
R_MOD linear ³⁾	R_{MODL}			4,5 kΩ	$V_{INLow} \leq 2,0 \text{ V}_p$
R_MOD nonlinear ³⁾	R_{MODNL}			3,6 kΩ	$V_{INLow} \geq 2,0 \text{ V}_p$
Resonance Capacitor ³⁾					
	$C_{ResInit}$	189 pF	210 pF	231 pF	$V_{IN} = 4,0 \text{ V}_p$

EEPROM					
Write Current ⁴⁾	I_W			25 μA	$V_{DD} = 2,8 \text{ V}$
Read Current ⁴⁾	I_R			9 μA	$V_{DD} = 2,8 \text{ V}$
Data Retention	Years	10			@ 55°C
Write Endurance	Cycles	100.000			

1) $|V_{IN}| = |V_{IN1} - V_{IN2}|$... voltage between connection pads

2) V_{INHigh} input voltage before modulation
 V_{INLow} input voltage during modulation
 T_{MOD} duration of the modulation

3) @ $R_i = 10 \text{ k}\Omega$ resistance of measurement equipment

4) tested on silicon level

3 Drawing of the Chip Module HT1 MOA3 S30

3.1 Drawing of the Reel

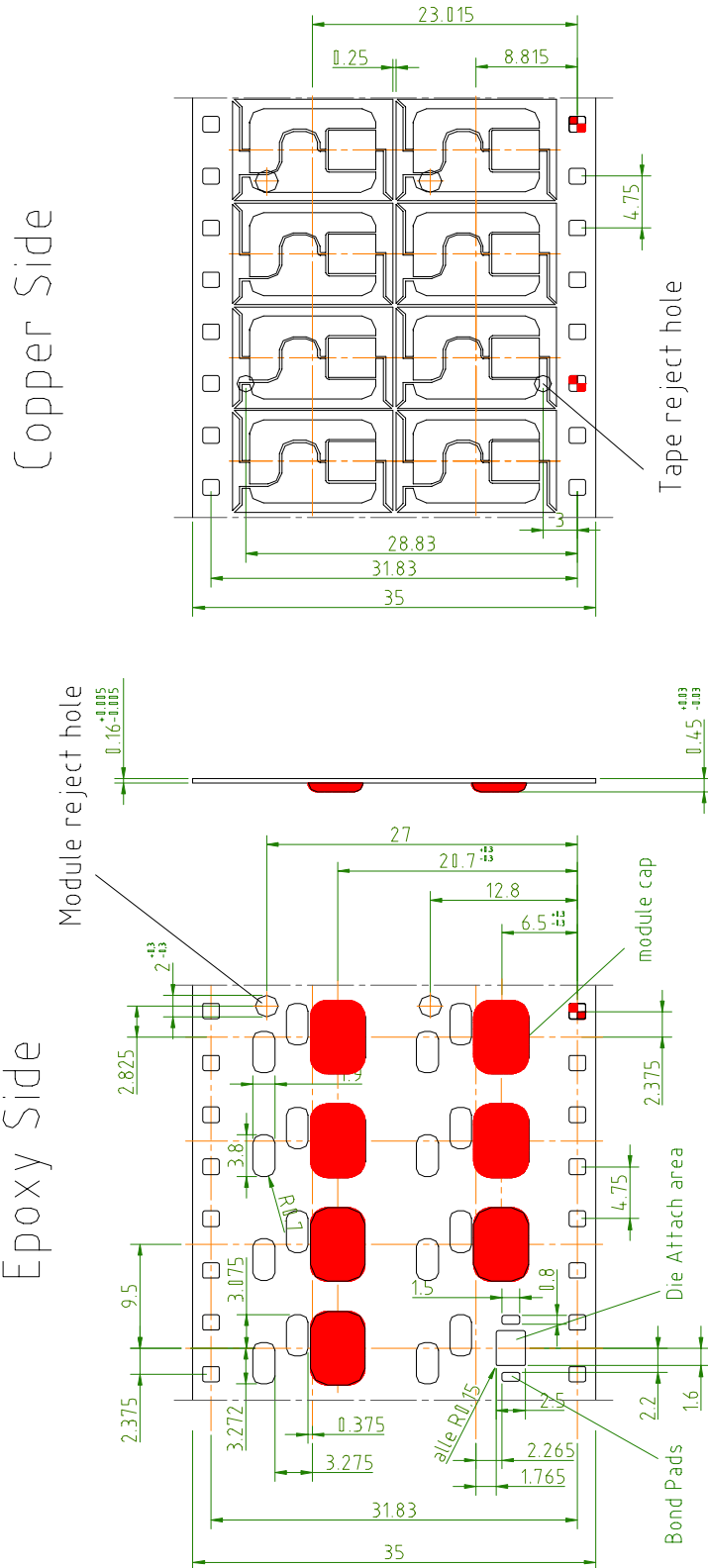

3.2 Module outline suggestion

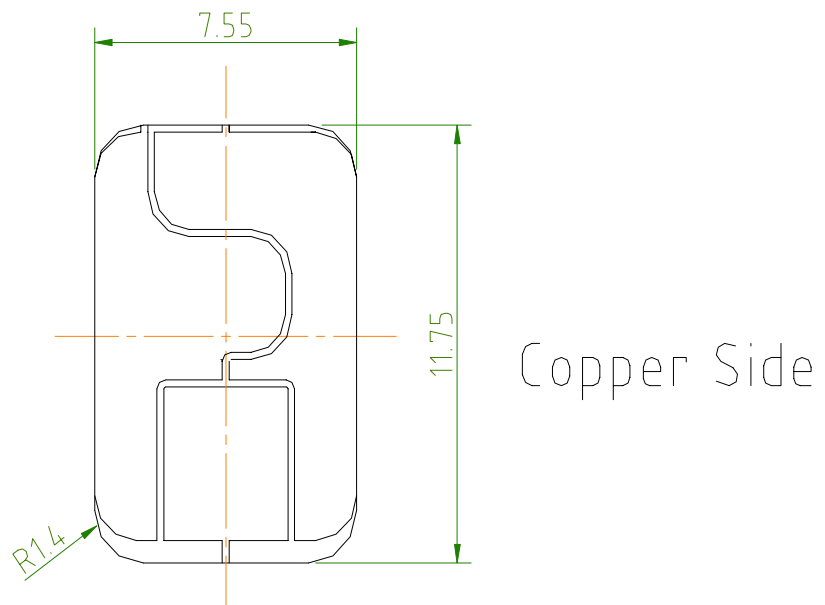
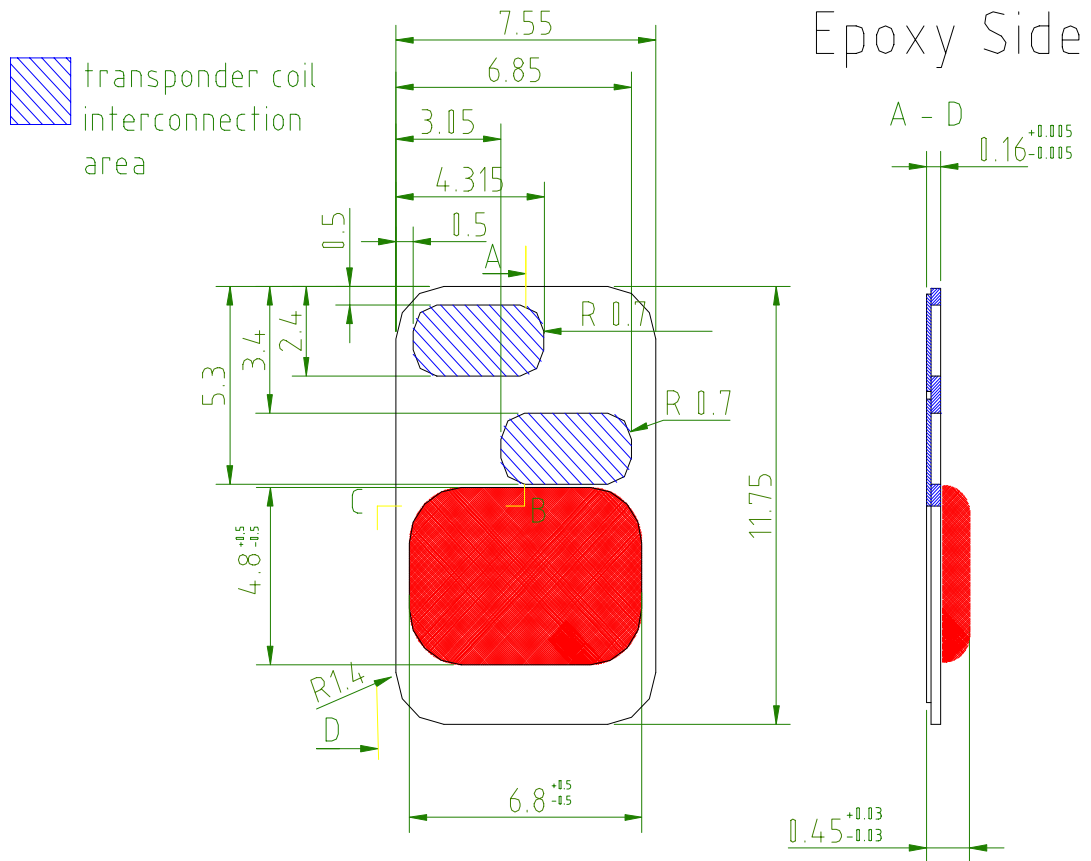

3.3 Splicing Specification

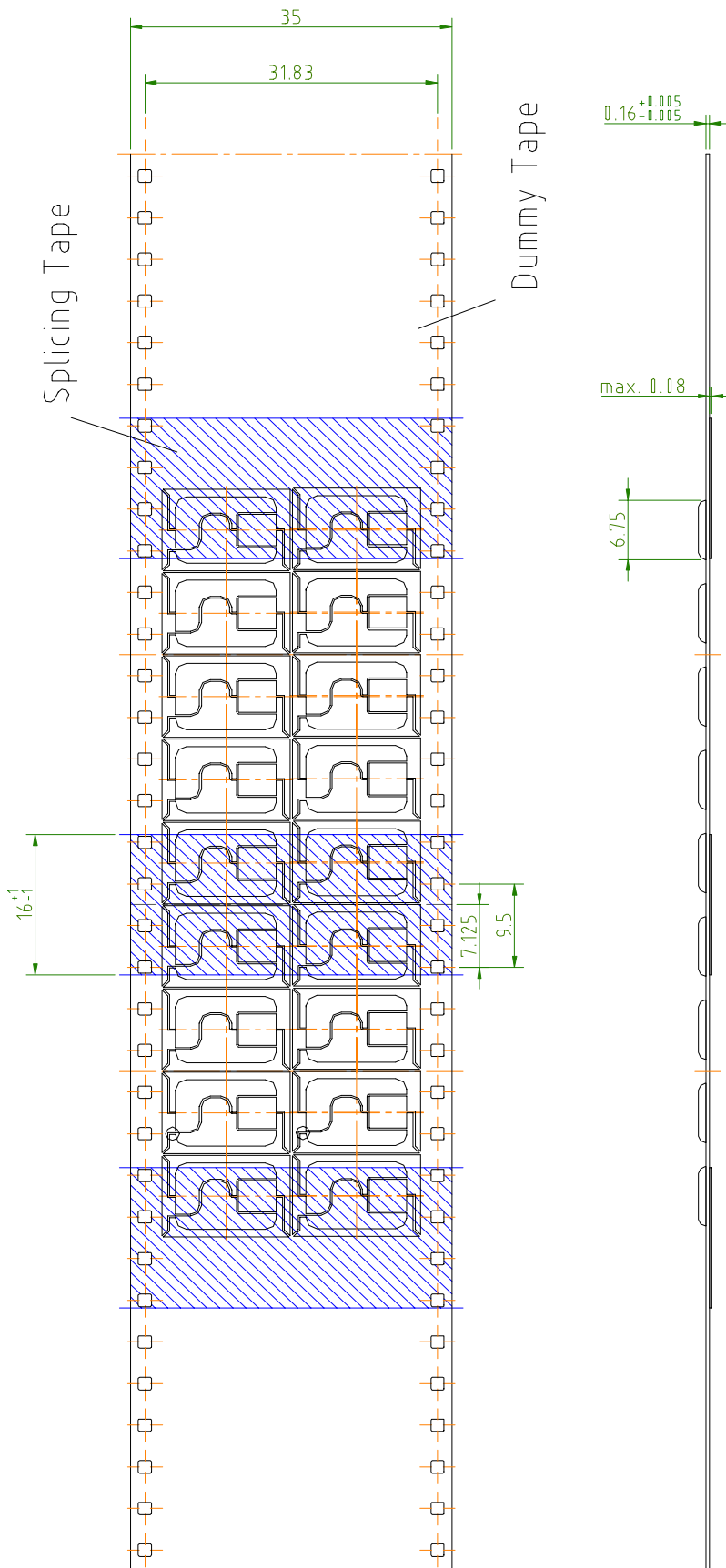

4 Coil Specifications

The HITAG 1 chip module has to be connected to a coil whose parameters are briefly described in the following.

Equivalent circuit of the transponder

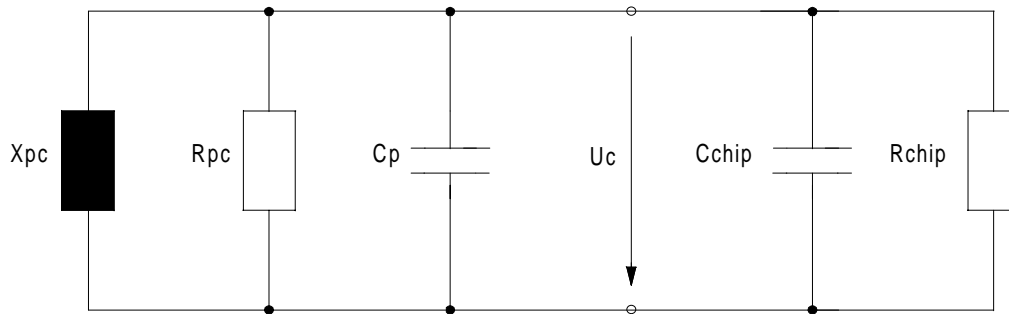

U_c	...	voltage at the connection pads
f_{res}	...	resonant frequency of the transponder
X_{pc}	...	parallel reactance of the coil ($f = 125$ kHz)
R_{pc}	...	parallel resistance of the coil ($f = 125$ kHz)
C_p	...	parasitic capacitance of the package
C_{chip}	...	capacitance of the chip ($U_c > 4$ Vpp)
R_{chip}	...	resistance of the chip
f_{resc}	...	self resonant frequency of the coil
L_{pc}	=	$X_{pc}/2\pi f$ ($f = 125$ kHz)
L_{pc}	=	7.72 mH \pm x % ($C_p = 0$, x depends on the coil production process)
C_{chip}	=	210 pF \pm 10 %
R_{pc}	>	45 k Ω
f_{resc}	>	750 kHz

Note: The parasitic capacitance of the package (C_p) must be considered.

$$f_{res} = \frac{1}{2\pi\sqrt{(C_{chip} + C_p) \cdot L_{pc}}} = 125 \text{ kHz} \Rightarrow L_{pc} = \frac{1}{(2\pi f_{res})^2 (C_{chip} + C_p)}$$

Typical values for C_p

hot laminated cards: $C_p = 1.5$ pF

moulded tags: $C_p = 6.0$ pF

For a rough estimation ($\pm 10\%$) of the number of coil windings following formula can be used. It is assumed that the winding is done in circular form.

$$N = \sqrt[1.85]{\frac{L}{2 U \ln\left(\frac{u}{d}\right)}}$$

- N ... Number of windings
L ... Inductance [nH]
U ... average coil circumference [cm]
d ... copper diameter [mm]
u ... average coil circumference [mm]

For fine tuning a measurement of the inductance and an according adjustment of the number of windings is necessary. This process always needs some iterations.

5 Functional Description of HITAG 1

5.1 Memory Organization

The 2 kBit EEPROM memory on the transponder is divided into 16 blocks.

Every block consists of 4 pages. A page is the smallest access unit.

Every page consists of 4 bytes (at 8 bits).

Block access is only available for Blocks 2-15, page access is available for Pages 0-63.

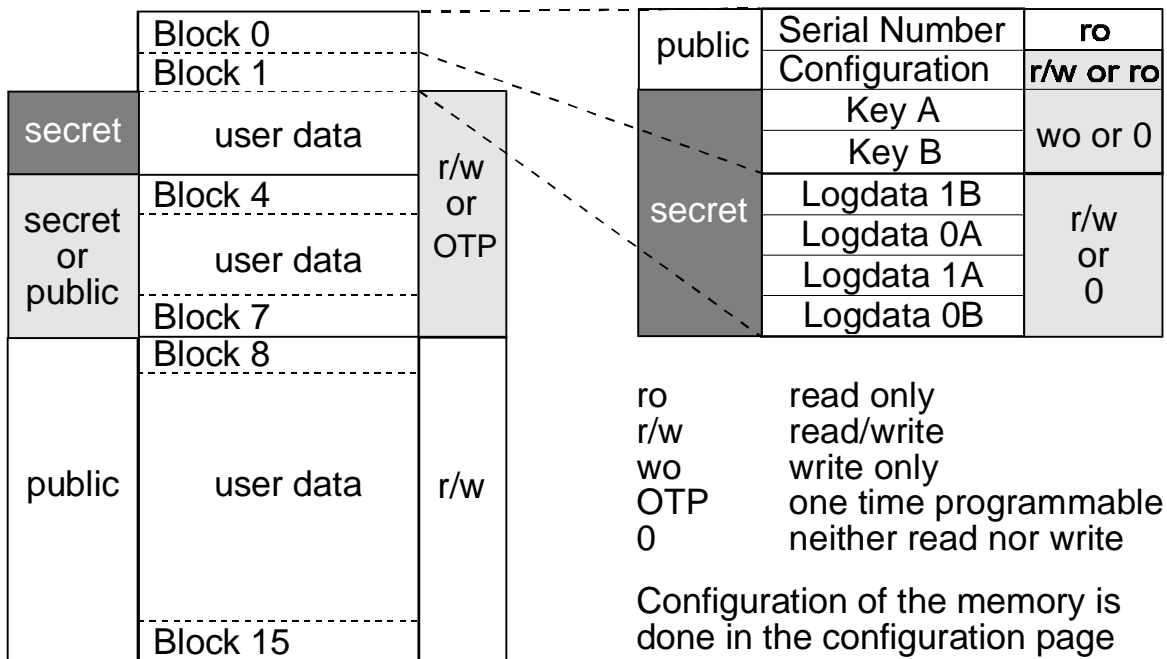

Areas (or settings) with light dark background may be configured by the OEM client using the Configuration Page (Page 1).

Memory locations marked with "secret" can only be accessed after a mutual authentication. An enciphered data communication is used in that area.

Memory locations marked with "public" can be accessed without mutual authentication, no encryption is used.

Block 0 includes the unique serial number (programmed during the production process), the Configuration Page (configuration of the memory area) and the keys, Block 1 includes the logdata.

Blocks 4 to 7 can be used either as secret or public areas (configurable), and Blocks 2 to 7 either as read / write or read only areas (configurable). You can also modify keys and logdata and prevent them from being accessed.

Finally the Configuration Page itself can be set to read only.

It is extremely important to be particularly careful when using the Configuration Page (it only can be set to read only once!), keys and logdata as you can lose access to the secret area on the transponder in case of a mistake.

ATTENTION:

Changing of the Configuration Page (Page 1), Keys and Logdata must be done in secure environment. The transponder must not be moved out of the communication field of the antenna during programming! We recommend to put the transponder close to the antenna (zero-distance) and not to remove it during programming.

5.2 Anticollision

Anticollision Mode in long range applications including HITAG 1 transponders permits you to process several transponders simultaneously. Theoretically up to 2^{32} transponders can be processed simultaneously. In practice this number is limited, because of the mutual influence of the transponders - they detune each other, if there are too many too close to each other.

The currently used read/write device must also support full anticollision feature (e.g. HTRM800). For read/write devices without that feature only one transponder is handled even if there are several transponders within the communication field of the antenna. In this case either no communication takes place or the "stronger" or closer transponder takes over.

By muting a selected transponder (HALT Mode) another transponder that is to be found in the communication field of the antenna can be recognized.

5.3 Operation Modes and Configuration

5.3.1 Modes of Operation

The HITAG 1 can be operated in two modes (Standard Protocol Mode, Advanced Protocol Mode) that **cannot** be configured using the Configuration Page, but via special host commands.

Advanced Protocol Mode is not available for HITAG 1 transponders based on ASIC HT1 ICS30 01x (only available for HITAG 1 transponders based on ASIC HT1 ICS30 02x) and uses, above all, an additional Cyclic Redundancy Check (CRC) for read operations.

5.3.2 Configuration

The Configuration Page consists of 4 Configuration Bytes, the first two bytes are used for configuration, the other two bytes can be used freely.

The bitmaps in Configuration Bytes 0 and 1 determine the configuration of the memory, i.e. they define which area is secret or public, read/write, read only, write only or neither read nor write.

You can allocate and write the Configuration Page until it is locked (Bit 4 of Configuration Byte 1 is set to '0').

After that these bytes are read only bytes and the configuration of the transponder memory cannot be changed any more.

ATTENTION: Once set to read only the Configuration Page cannot be changed back to read/write again (transponder is hardware protected)!

Configuration Bytes 2 and 3: These two bytes, too, are set to read only by the OEM Lock Bit (Configuration Byte 1 / Bit 4 = "0"). Considering that fact you can use these two bytes freely. They will not affect memory configuration.

Explanations of abbreviations used:

r/w	read and write
ro	read only
wo	write only
0	neither read nor write

Configuration Byte 0:

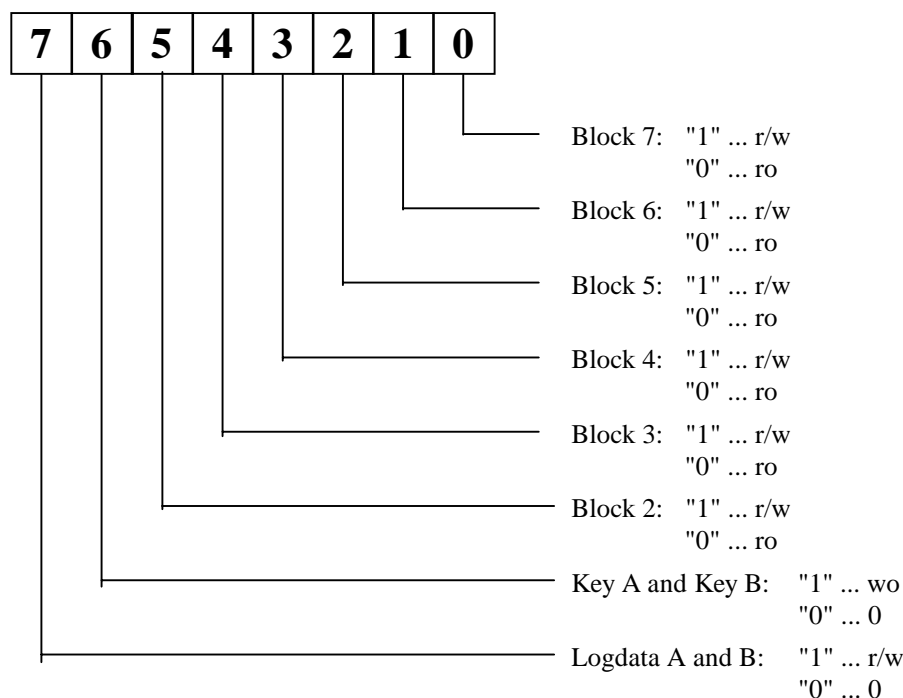

Configuration Byte 0 / Bit 7:

Bit 7 = '1': Logdata can be read and written to.

Bit 7 = '0': Logdata cannot be accessed.

This bit can be set or reset until Bit 4 of Configuration Byte 1 is set to '0'.

For further information on Logdata and Keys see chapter "Definition of Keys and Logdata".

Configuration Byte 0 / Bit 6:

Bit 6 = '1': Keys can only be written to.

Bit 6 = '0': Keys cannot be accessed.

This bit can be set or reset until Bit 4 of Configuration Byte 1 is set to '0'.

For further information on Logdata and Keys see chapter "Definition of Keys and Logdata".

Configuration Byte 0 / Bits 0 ... 5:

If one of these Configuration Bits is '1', the corresponding block of the transponder can be read and written.

If the bit is set to '0', the corresponding block can only be read.

Within one block the configuration is always identical, that means either all 4 pages are read/write or all of them are read only.

These bits can be set or reset until Bit 4 of Configuration Byte 1 is set to '0'.

5.4 Configuration of Delivered HITAG 1 Transponders

HITAG 1 transponders are delivered with the following configuration by Philips Semiconductors:

Unique Serial Number:

Serial Number: Read Only - fixed

Configuration Byte 0:

Logdata: '1' = r/w - can be changed
 Key A, Key B: '1' = wo - can be changed
 Blocks 2 - 7: '1' = r/w - can be changed

Configuration Byte 1:

OEM Lock Bit: '1' = Configuration Page is r/w - can be changed
 Blocks 4 - 7: '1' = public - can be changed

Value for Transport Keys, Transport Logdata:

0x00000000

RECOMMENDATION:

Before delivering transponders to end users, the Configuration Page should be set to read only (Configuration Byte 1/Bit 4 = '0').

5.5 Definition of Keys and Logdata

In order to be able to read data from the secret area of a transponder, you have to carry out a procedure called authentication. To do this you need special data (keys).

After transmitting the according command the authentication is automatically carried out by the read/write device.

Keys are cryptographic codes, which determine data encryption during data transfer between read/write device and transponder.

Two keys (Key A and Key B) which you can use independently of each other, have been installed for security and flexibility reasons. The identity of either Key A or Key B on the read/write device and on the transponder is sufficient.

Logdata represent "passwords" needed to gain access to secret areas on the transponder. A pair of logdata is included with every cryptographic key (Key A and Key B). This logdata pair has to be identical both on the transponder and the read/write device.

ad Key A:	Logdata 0 A	"Password" which the transponder sends to the read/write device and which is verified by the latter.
	Logdata 1 A	"Password" which the read/write device sends to the transponder and which is checked for identity by the latter.
ad Key B:	Logdata 0 B and Logdata 1 B	analogous to Key A

It is important that the following values are in accordance with each other, i.e. the respective data on the read/write device and on the transponder have to be identical pairs:

on the read/write device		on the transponder	
KEY A	↔	KEY A	} Set A
LOGDATA 0A	↔	LOGDATA 0A	
LOGDATA 1A	↔	LOGDATA 1A	
<hr/>			
KEY B	↔	KEY B	} Set B
LOGDATA 0B	↔	LOGDATA 0B	
LOGDATA 1B	↔	LOGDATA 1B	

The keys and logdata are predefined by Philips Semiconductors by means of defined Transport Keys (both keys show the same bit map) and Transport Logdata (all logdata show the same bit map), see also chapter “Configuration of Delivered HITAG 1 Transponders“.

They can be written to, which means that they can be changed.

ATTENTION: Keys and Logdata only can be changed if their current values are known!

6 Quality Inspection

Quality inspection is performed with statistical quality control according to ISO 2859 part 1, with AQL1.0.

Optical Properties	scratches, encapsulation failures, gold discolouration, delamination	according to the reference sample catalogue
Geometrical Properties	width	measured with gauge
	length	measured with gauge
	overall thickness	measured with micrometer at the center of the glob top
Electrical Properties	operation	basic read/write operations
Shipment Quantity		
Packing and Labeling		

7 Characterisation and Test of the Final Transponder

7.1 Characterisation of the Transponder

The parameters recommended to be characterised for the transponder are:

Parameter		Comment
Resonant frequency	f_{res}	Transponder does not modulate Resonant frequency @ $T_{amb} = 22^{\circ}C$, @ B_{TH}
Threshold value	B_{TH}	Start of modulation
Threshold value for READ	B_{RD}	Command READ_PAGE OK
Threshold value for WRITE	B_{WR}	Command WRITE_PAGE OK

For the measurement of these parameters we recommend to use the test equipment available from **SCEMTEC, Marienheide-Rodt, Germany (Transponder Measurement System STM-1)**. This device also supports functional testing (besides parameter testing). Therefore it can also be used as production test equipment for the final transponder test. For further information please contact Scemtec GmbH.

7.2 Final Test of the Transponder

In addition to the equipment described in the previous chapter Philips Semiconductors offers a device for a final functional test of transponders, the HITAGTM Test System HT OT490. Parameter tests are not supported by this device.

Basic flow for production and test:

1. Assembly of transponders
2. Functional test and final test of the EEPROM

Since the Keys and Logdata are changed during final test the Configuration and personalization must take place after the final test. The final test is disabled (not reversible) by setting the Tag-test mode bit to 0.

For the final test of transponders we recommend to use the HITAGTM Test System HT OT490 of Philips Semiconductors or the Transponder Measurement System STM-1 of Scemtec.

8 Ordering Information

Type Name	Description	Ordering Number
HT1 MOA3 S30/E/3	HITAG 1 S30 Chip Module, reels	9352 600 61118
HT1 MOA3 S30/E/1	HITAG 1 S30 Chip Module, bulk	9352 602 18122

Definitions

Data sheet status	
Objective specification	This data sheet contains target or goal specifications for product development.
Preliminary specification	This data sheet contains preliminary data; supplementary data may be published later.
Product specification	This data sheet contains final product specifications.
Limiting values	
Limiting values given are in accordance with the Absolute Maximum Rating System (IEC 134). Stress above one or more of the limiting values may cause permanent damage to the device. These are stress ratings only and operation of the device at these or at any other conditions above those given in the Characteristics section of the specification is not implied. Exposure to limiting values for extended periods may affect device reliability.	
Application information	
Where application information is given, it is advisory and does not form part of the specification.	

Life support applications

These products are not designed for use in life support appliances, devices, or systems where malfunction of these products can reasonably be expected to result in personal injury. Philips Semiconductors' customers using or selling these products for use in such applications do so on their own risk and agree to fully indemnify Philips Semiconductors for any damages resulting from such improper use or sale.

- this page intentionally left blank -

Philips Semiconductors - a worldwide company

Argentina: see South America

Australia: 34 Waterloo Road, NORTHRYDE, NSW 2113,
Tel. +612 9805 4455, Fax. +612 9805 4466

Austria: Computerstraße 6, A-1101 WIEN, P.O.Box 213,
Tel. +431 60 101, Fax. +431 30 101 1210

Belarus: Hotel Minsk Business Centre, Bld. 3, r.1211, Volodarski Str. 6,
220050 MINSK, Tel. +375172 200 733, Fax. +375172 200 773

Belgium: see The Netherlands

Brazil: see South America

Bulgaria: Philips Bulgaria Ltd., Energoproject, 15th floor,
51 James Bourchier Blvd., 1407 SOFIA
Tel. +3592 689 211, Fax. +3592 689 102

Canada: Philips Semiconductors/Components,
Tel. +1800 234 7381

China/Hong Kong: 501 Hong Kong Industrial Technology Centre,
72 Tat Chee Avenue, Kowloon Tong, HONG KONG,
Tel. +85223 19 7888, Fax. +85223 19 7700

Colombia: see South America

Czech Republic: see Austria

Denmark: Prags Boulevard 80, PB 1919, DK-2300 COPENHAGEN S,
Tel. +4532 88 2636, Fax. +4531 57 1949

Finland: Sinikalliontie 3, FIN-02630 ESPOO,
Tel. +3589 61 5800, Fax. +3589 61 580/xxx

France: 4 Rue du Port-aux-Vins, BP 317, 92156 SURESNES Cedex,
Tel. +331 40 99 6161, Fax. +331 40 99 6427

Germany: Hammerbrookstraße 69, D-20097 HAMBURG,
Tel. +4940 23 53 60, Fax. +4940 23 536 300

Greece: No. 15, 25th March Street, GR 17778 TAVROS/ATHENS,
Tel. +301 4894 339/239, Fax. +301 4814 240

Hungary: see Austria

India: Philips INDIA Ltd., Shivsagar Estate, A Block, Dr. Annie Besant Rd.
Worli, MUMBAI 400018, Tel. +9122 4938 541, Fax. +9122 4938 722

Indonesia: see Singapore

Ireland: Newstead, Clonskeagh, DUBLIN 14,
Tel. +3531 7640 000, Fax. +3531 7640 200

Israel: RAPAC Electronics, 7 Kehilat Saloniki St., TEL AVIV 61180,
Tel. +9723 645 0444, Fax. +9723 649 1007

Italy: Philips Semiconductors, Piazza IV Novembre 3,
20124 MILANO, Tel. +392 6752 2531, Fax. +392 6752 2557

Japan: Philips Bldg. 13-37, Kohnan 2-chome, Minato-ku, TOKYO 108,
Tel. +813 3740 5130, Fax. +813 3740 5077

Korea: Philips House, 260-199, Itaewon-dong, Yonsan-ku, SEOUL,
Tel. +822 709 1412, Fax. +822 709 1415

Malaysia: No. 76 Jalan Universiti, 46200 PETALING JAYA, Selangor,
Tel. +60 3750 5214, Fax. +603 757 4880

Mexico: 5900 Gateway East, Suite 200, EL PASO, Texas 79905,
Tel. +9 5800 234 7381

Middle East: see Italy

Netherlands: Postbus 90050, 5600 PB EINDHOVEN, Bldg. VB,
Tel. +3140 27 82785, Fax +3140 27 88399

New Zealand: 2 Wagener Place, C.P.O. Box 1041, AUCKLAND,
Tel. +649 849 4160, Fax. +649 849 7811

Norway: Box 1, Manglerud 0612, OSLO,
Tel. +4722 74 8000, Fax. +4722 74 8341

Philippines: Philips Semiconductors Philippines Inc.,
106 Valero St. Salcedo Village, P.O.Box 2108 MCC, MAKATI,
Metro MANILA, Tel. +632 816 6380, Fax. +632 817 3474

Poland: Ul. Lukiska 10, PL 04-123 WARSZWA,
Tel. +4822 612 2831, Fax. +4822 612 2327

Portugal: see Spain

Romania: see Italy

Russia: Philips Russia, Ul. Usatcheva 35A, 119048 MOSCOW,
Tel. +7095 247 9145, Fax. +7095 247 9144

Singapore: Lorong 1, Toa Payoh, SINGAPORE 1231,
Tel. +65350 2538, Fax. +65251 6500

Slovakia: see Austria

Slovenia: see Italy

South Africa: S.A. Philips Pty Ltd., 195-215 Main Road Martindale,
2092 JOHANNESBURG, P.O.Box 7430 Johannesburg 2000,
Tel. +2711 470 5911, Fax. +2711 470 5494

South America: Al. Vicente Pinzon, 173 - 6th floor,
04547-130 Sao Paulo, SAO PAULO - SP, Brazil,
Tel. +5511 821 2333, Fax. +5511 829 1849

Spain: Balmes 22, 08007 BARCELONA,
Tel. +343 301 6312, Fax. +343 301 4107

Sweden: Kottbygatan 7, Akalla, S-16485 STOCKHOLM,
Tel. +468 632 2000, Fax. +468 632 2745

Switzerland: Allmendstraße 140, CH-8027 ZÜRICH,
Tel. +411 488 2686, Fax. +411 481 7730

Taiwan: Philips Taiwan Ltd., 2330F, 66,
Chung Hsiao West Road, Sec. 1, P.O.Box 22978,
TAIPEI 100, Tel. +8862 382 4443, Fax. +8862 382 4444

Thailand: Philips Electronics (Thailand) Ltd.,
209/2 Sanpavuth-Bangna Road Prakanong, BANGKOK 10260,
Tel. +662 745 4090, Fax. +662 398 0793

Turkey: Talapasa Cad. No. 5, 80640 GÜLTEPE/ISTANBUL,
Tel. +90212 279 2770, Fax. +90212 282 6707

Ukraine: Philips Ukraine, 4 Patrice Lumumba Str., Building B, Floor 7,
252042 KIEV, Tel. +38044 264 2776, Fax. +38044 268 0461

United Kingdom: Philips Semiconductors Ltd., 276 Bath Road, Hayes,
MIDDLESEX UM3 5BX, Tel. +44181 730 5000, Fax. +44181 754 8421

United States: 811 Argus Avenue, SUNNYVALE, CA94088-3409,
Tel. +1800 234 7381

Uruguay: see South America

Vietnam: see Singapore

Yugoslavia: Philips, Trg N. Pasica 5/v, 11000 BEOGRAD,
Tel. +38111 625 344, Fax. +38111 635 777

Philips Semiconductors, Mikron-Weg 1, A-8101 Gratkorn, Austria Fax: +43 / 3124 / 299 - 270

For all other countries apply to: Philips Semiconductors, Marketing & Sales Communications,
Building BE-p, P.O.Box 218, 5600 MD EINDHOVEN, The Netherlands, Fax: +3140 27 24825

Internet: <http://www.semiconductors.philips.com>

© Philips Electronics N.V. 1996

SCB52

All rights are reserved. Reproduction in whole or in part is prohibited without the prior written consent of the copyright owner.

The information presented in this document does not form part of any quotation or contract, is believed to be accurate and reliable and may be changed without any notice. No liability will be accepted by the publisher for any consequence of its use. Publication thereof does not convey nor imply any license under patent- or other industrial or intellectual property rights.



PHILIPS