

PREPARED BY: <i>Y. Takenaka</i>	DATE: <i>Jan 19 2000</i>	SHARP ELECTRONIC COMPONENTS GROUP SHARP CORPORATION SPECIFICATION	SPEC.No. DG-001019
APPROVED BY: <i>M. Akie</i>	DATE: <i>Jan 19 2000</i>		ISSUE Jan/19/00
			PAGE 13 pages
			REPRESENTATIVE DIVISION: Opto-Electronic Devices Division

DEVICE SPECIFICATION FOR
Light Emitting Diode
MODEL No. **LT1E90A**

- These specification sheets include materials protected under the copyright of Sharp Corporation ("Sharp"). Please do not reproduce or cause anyone to reproduce them without Sharp's consent.
- When using this product, please observe the absolute maximum ratings and the instructions for use outlined in these specification sheets, as well as the precautions mentioned below. Sharp assumes no responsibility for any damage resulting from use of the product which does not comply with the absolute maximum ratings and the instructions included in these specification sheets, and the precautions mentioned below.

(Precautions)

 - This product is designed for use in the following application areas;
 - * OA equipment * Audio visual equipment * Home appliance
 - * Telecommunication equipment (Terminal) * Measuring equipment
 - * Tooling machines * Computers
 If the use of the product in the above application areas is for equipment listed in paragraphs (2) or (3), please be sure to observe the precautions given in those respective paragraphs.
 - Appropriate measures, such as fail-safe design and redundant design considering the safety design of the overall system and equipment, should be taken to ensure reliability and safety when this product is used for equipment which demands high reliability and safety in function and precision, such as ;
 - * Transportation control and safety equipment (aircraft, train, automobile etc.)
 - * Traffic signals * Gas leakage sensor breakers * Rescue and security equipment
 - * Other safety equipment
 - Please do not use this product for equipment which require extremely high reliability and safety in function and precision, such as ;
 - * Space equipment * Telecommunication equipment (for trunk lines)
 - * Nuclear power control equipment * Medical equipment
 - Please contact and consult with a Sharp sales representative if there are any questions regarding interpretation of the above three paragraphs.
- Please contact and consult with a Sharp sales representative for any questions about this product.

CUSTOMER'S APPROVAL

DATE: _____

BY: _____

DATE: *Jan 19 2000*
PRESENTED BY: *M. Katoh*
M. Katoh,
Department General Manager of
Engineering Dept., III
Opto-Electronic Devices Division
Electronic Components Group
SHARP CORPORATION

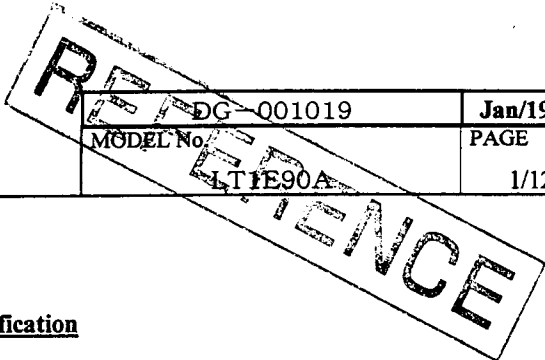

EDG-001019	Jan/19/00
MODEL No. LT1E90A	PAGE 1/12



LT1E90A Specification

- 1. Application
This specification applies to the light emitting diode device Model No. LT1E90A.
[GaP(Yellow-green)chip LED device]

- 2. Outline dimensions and terminal connections Refer to the attached sheet Page 2.

- 3. Ratings and characteristics Refer to the attached sheet Page 3~5.
 - 3-1. Absolute maximum ratings
 - 3-2. Electro-optical characteristics
 - 3-3. Derating Curve
 - 3-4. Characteristics Diagram

- 4. Reliability Refer to the attached sheet Page 6.
 - 4-1. Test items and test conditions
 - 4-2. Failure judgement criteria

- 5. Incoming inspection Refer to the attached sheet Page 7.
 - 5-1. Inspection method
 - 5-2. Description of inspection and criteria

- 6. Taping specification Refer to the attached sheet Page 8~10.
 - 6-1. Taping
 - 6-2. Packing specification
 - 6-3. Label
 - 6-4. Luminous intensity rank

- 7. Soldering Refer to the attached sheet Page 11.
 - 7-1. Reflow soldering

- 8. Precautions for use Refer to the attached sheet Page 12.
 - 8-1. Precautions matters for designing circuit
 - 8-2. Cleaning method

- 9. Environment Refer to the attached sheet Page 12.
 - 9-1. Ozonosphere destructive chemicals.
 - 9-2. Bromic non-burning materials

REFERENCE

SHARP

2. Outline dimensions and terminal connections

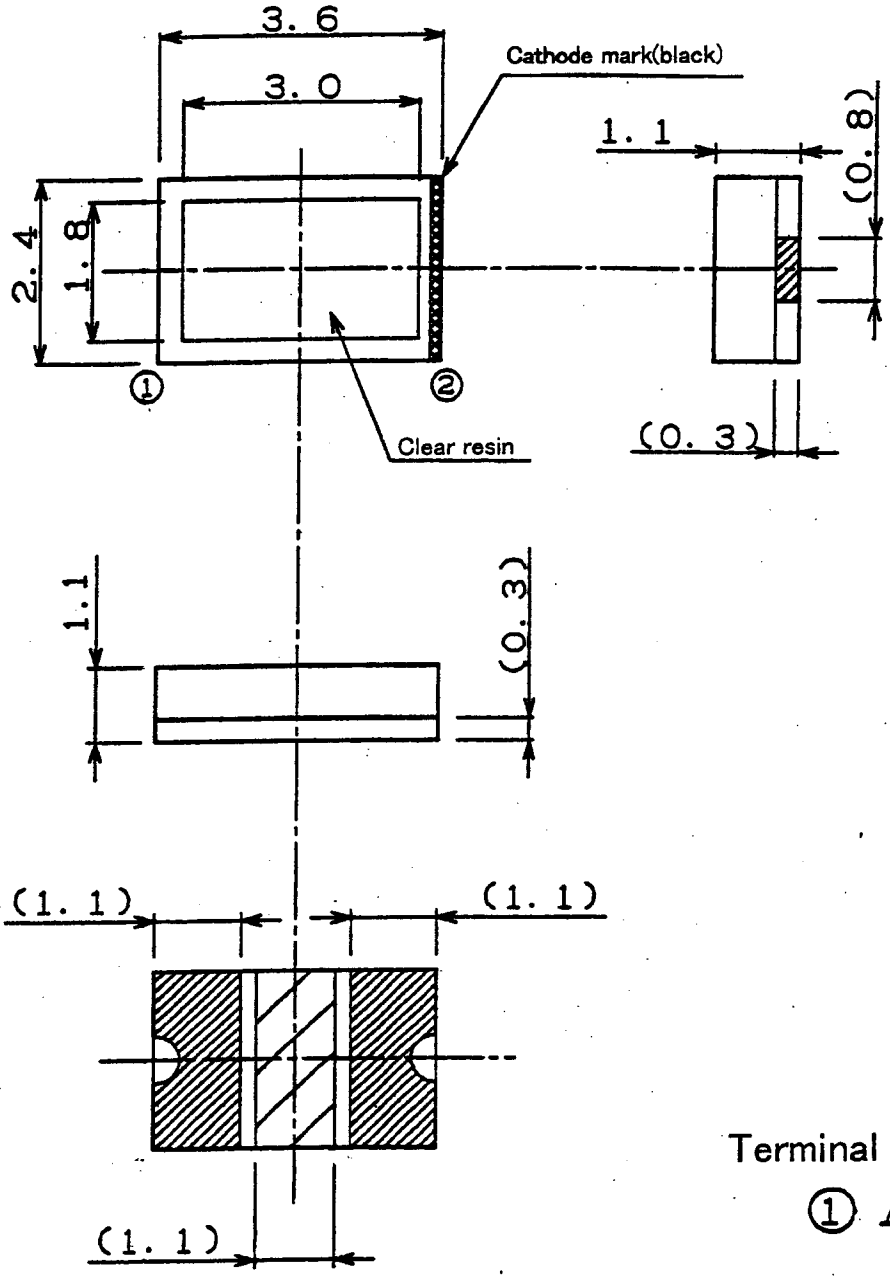

Terminal connection

- ① Anode
 - ② Cathode
- ① —|>— ②

Unit	Material	Finish	Drawing No.
mm	PWB: Glass-Epoxy Resin: Epoxy	Au Plated	51201002

REFERENCE



3. Ratings and characteristics

3-1. Absolute maximum ratings (Ta=25°C)

Parameter	Symbol	Rating	Unit
Power dissipation	P	84	mW
Continuous forward current	I _F	30	mA
Peak forward current(Note 1)	I _{FM}	50	mA
Derating factor	DC	0.4	mA/°C
	Pulse	0.67	mA/°C
Reverse voltage	V _R	5	V
Operating temperature	T _{opr}	-25 ~ 85	°C
Storage temperature	T _{stg}	-25 ~ 100	°C
Soldering temperature(Note 2)	T _{sol}	260	°C

(Note1) Duty ratio=1/10,Pulse width=0.1ms

(Note2) Manual soldering Max.3s

3-2. Electro-optical characteristics (Ta=25°C)

Parameter	Symbol	Conditions	MIN.	TYP.	MAX.	Unit
Forward voltage	V _F	IF=20mA	—	2.1	2.8	V
Luminous intensity (Note 3)	I _v		13.6	32	—	mcd
Peak emission wavelength	λ _p		—	565	—	nm
Spectrum radiation bandwidth	Δλ		—	30	—	nm
Reverse current	I _R	VR=4V	—	—	10	μA

(Note 3) Measured by SHARP EG&G MODEL550(Radiometer/Photometersyste (Tolerance: ±15%)



3-3. Derating Curve

Forward Current Derating Curve

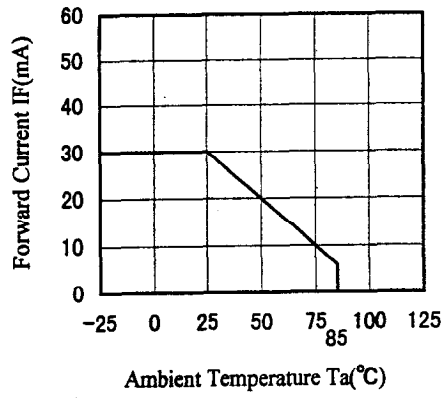

Peak Forward Current Derating Curve

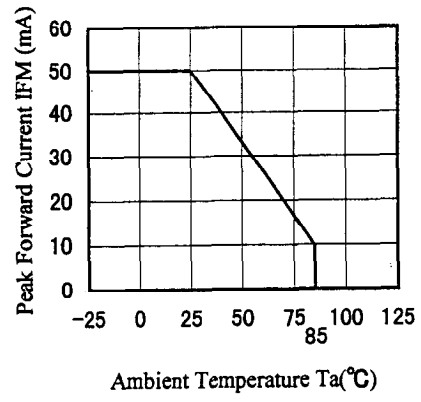

Peak Forward Current vs. Duty Ratio
($T_a=25^\circ\text{C}$)

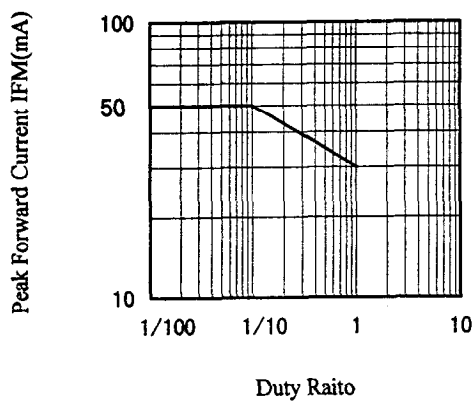



3-4. Characteristics Diagram(typ) (Note 1)

Forward Current vs. Forward Voltage

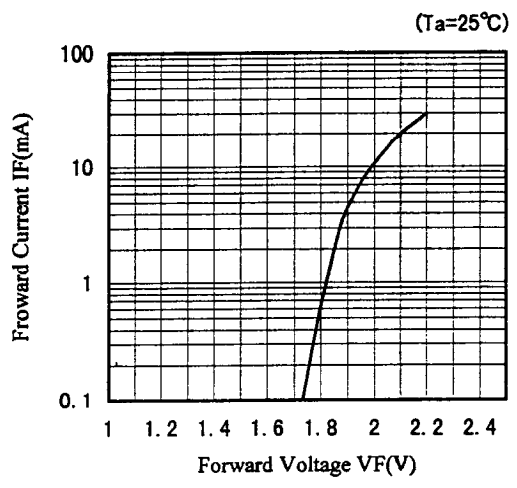

Relative Luminous Intensity vs. Ambient Temperature

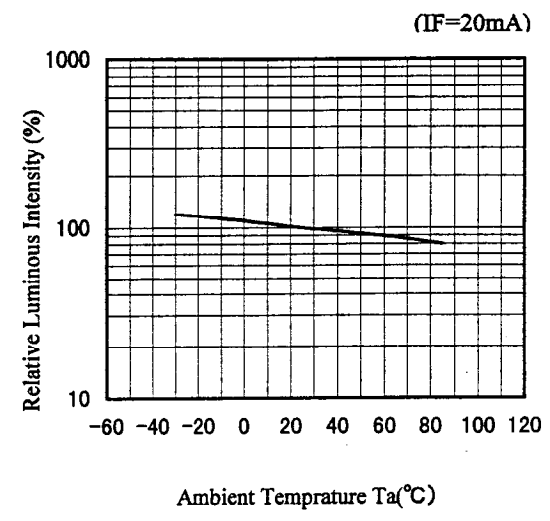

Relative Luminous Intensity vs. Forward Current

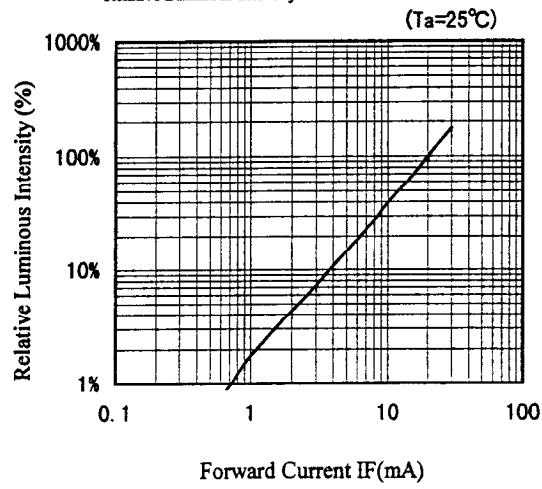

(Note 1) Above characteristic data are typical data and not a guaranteed data.

REFERENCE



4. Reliability

The reliability of products shall be satisfied with items listed below.

4-1. Test items and test conditions

Confidence level: 90%

Test items	Test conditions	Samples (n) Defective (C)	LTPD (%)
temperature cycling	-25°C(30min)~+100°C(30min),30times	n=22, C=0	10
High temp. and high humidity storage	Ta=+60°C, 90%RH, t=500h	n=22, C=0	10
High temperature storage	Ta=100°C,t=500h	n=22, C=0	10
Low temperature storage	Ta=-25°C,t=500h	n=22, C=0	10
Operating test	Ta=25°C,I _F =30mA,t=500h	n=22, C=0	10
Mechanical shock	15 000m/s ² , 0.5ms, 3times / ±X,±Y,±Z direction	n=11, C=0	20
Variable frequency vibration	200m/s ² , 100~2 000~100Hz/sweepfor 4min. , 4times/±X,±Y,±Z direction	n=11, C=0	20
Soldering heat	Refer to the attached sheet, Page 11/12 1times	n=11, C=0	20

4-2. Failure judgement criteria *1

Parameter	Symbol	Failure judgement criteria *2
Forward voltage	V _F	V _F > U.S.L. × 1.2
Reverse current	I _R	I _R > U.S.L. × 2.0
Luminous intensity	I _v	The first stage value × 0.5 > I _v

*1: Measuring condition is in accordance with specification.

*2: U.S.L. is shown by Upper Specification Limit.

REFERENCE



5. Incoming inspection

5-1. Inspection method

A single sampling plan, normal inspection level S-4 based on ISO 2859-1 shall be adopted.

5-2. Description of inspection and criteria

No.	Inspection items	Criteria	Defect	AQL
1	Radiation color	Not correct	Major defect	0.1%
2	Taping	Product inserted in reverse direction		
3	Solderability 1	Plating abnormality observed over 50% or greater percentage *1		
4	Electro-optical characteristics	Not conforming to the specification	Minor defect	0.4%
5	Outline dimensions	Not conforming to the specification		
6	Appearance	Dust : ϕ 0.8mm or more		
		Thread dust : 2.5mm or more in length and 0.25mm or more in width		
		Air bubbles : ϕ 0.8mm or more		
		Scratch : 2.5mm or more in length and 0.25mm or more in width However, the product is qualified as a good unit if the scratch does not touch the Auwire when seen from the front.		
		Resin barr : Over the unspecified tolerance		
		Resin ond plated crack : 0.3mm or more		
7	Solderability 2	could solder 50% or greater and less than 90% out of judgement area *1		

*1 Judgement area : The plated area of the product bottom

SHARP

6. Taping specification

6-1. Taping

6-1-1. Shape and dimension of tape(TYP.)

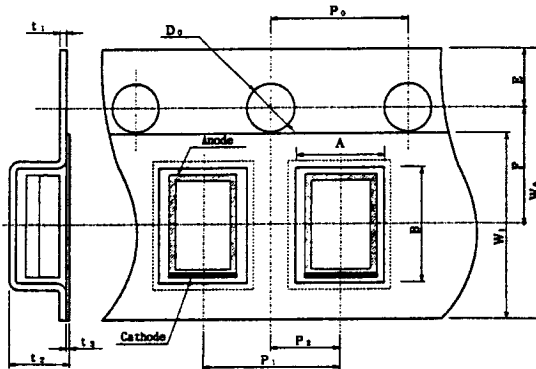

Parameter	Symbol	Dimension [mm](TYP.)	Remarks	
Concave square hole for part insertion	Vertical	A	2.90	Dimension excludes corner R at inside bottom
	Horizontal	B	3.9	
	Pitch	P_1	4.0	
Round sprocket hole	Diameter	D_0	1.5	Accumulated error $\pm 0.5\text{mm}/10$ pitch
	Pitch	P_0	4.0	
	Position	E	1.75	
Center to center dimension	Vert. dire	P_2	2.0	Center line of the concave square hole and round sprocket hole
	Hori. dire	F	3.5	
Cover tape	Width	W_1	5.5	
	Thickness	t_3	0.1	
Carrier tape	Width	W_0	8.0	
	Thickness	t_1	0.25	
Thickness of the entire unit	t_2	1.9	With cover tape and carrier tape combined	

6-1-2. Shape and dimension of reel(TYP.)

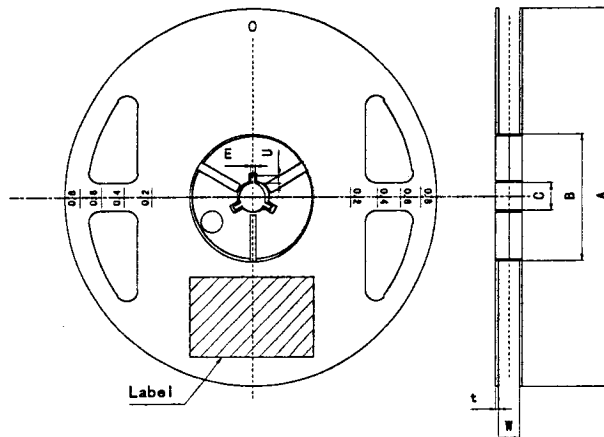

Parameter	Symbol	Dimension [mm](TYP.)	Remarks	
Frange	Diameter	A	$\phi 178$	
	Thickness	t	1.5	
	Inner space direction	W	10	Dimension of shaft core
Hub	External diameter	B	$\phi 60$	
	Spindle hole diameter	C	$\phi 13$	
	Key slit	Width	E	2.0
		Depth	U	4.5
Notation for part name etc.			Labeling on one side of flange.(part name,quantity,lot No.)	

REFERENCE

SHARP

6-1-3. Taping specification

(1) Lead tape:

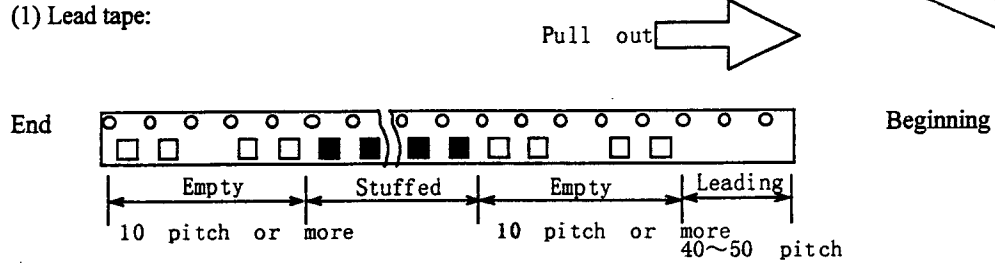

(2) Cover tape strength against peeling: $F=0.1\sim0.8N$ ($\theta = 10^\circ$ or less)

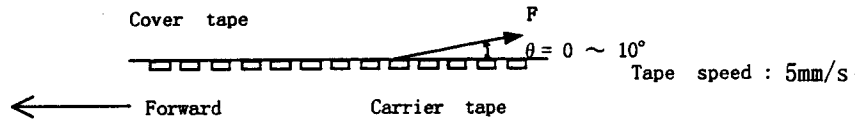

(3) Tape strength against bending:

The radius of bending circle should be 30mm or more.
If it is less than 30mm, the cover may peel.

- (4) Jointing of tape: There should not be joint of cover tape or carrier tape.
- (5) Quantity per reel: Average 3,000pcs. per reel
- (6) Mass per product: Average 0.02g / product
- (7) Mass per packing: Average 150g / packing
- (8) Others:
 - ① There should not be missing above continuous three products.
 - ② Products should be easily taken out.
 - ③ Products should not be attached to the cover tape at peeling.

6-2. Packing specification

6-2-1. Dampproof package

In other to avoid the absorption of humidity in transport and storage, the products are packed in aluminum sleeve.

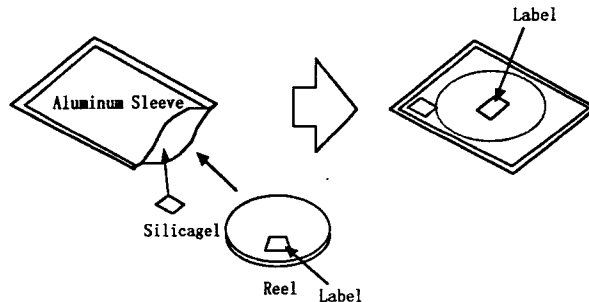

6-2-2. Strage conditions

Temperature : 5 to 30°C Humidity : less than 60%RH

6-2-3. Treatment after opening

- (1) Please make a soldering within 15 days after opening under following condition;
Temperature : 5 to 30°C Humidity : less than 60%RH
- (2) In case the devices are not used for a long time after opening ,the storage in dry box is recommendable.
Or it is better to repack the devices with a desiccative by the sealer and put them in the some storage conditions as 6-2-2. Then they should be used within 15 days.
- (3) Please make a soldering after a following baking treatment if unused term should be over the conditions of (2)
*Recommendable conditions:
 - ① in taping
Temperature:60°C to 65°C, Time:36 to 48 hours
 - ② in individual (on PWB or metallic tray)
Temperature:100°C to 120°C , Time:2 to 3 hours

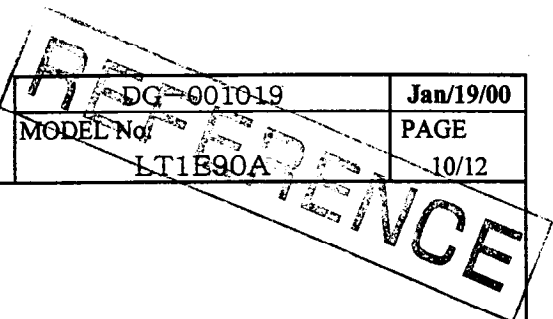

SHARP

6-3. Label

SHARP CORPORATION		
PART No.	LT1E90A	← Model number
QUANTITY	3000	← Quantity of products
[Bar code area]		← EIAJ C-3 Bar code
[Bar code area]		← EIAJ C-3 Bar code
LOT No. KA99B19	RANK ○	← Lot number(Note1) and Luminous rank
<EIAJ C-3> MADE IN JAPAN		← Production country

(Note1) Lot number indication

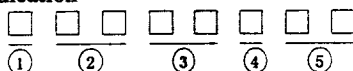

- ① Production plant code(to be indicated alphabetically)
- ② Production lot(single or double figures)
- ③ Year of production(the last two figures of the year)
- ④ Month of production
(to be indicated alphabetically with January corresponding to A)
- ⑤ Date of production(01~31)

6-4. Luminous intensity rank (Note2) (Note3)

(Ta=25°C)

Rank	Luminous intensity		Unit	Condition
A	13.6	~ 22.1	mcd	I _F =20mA
B	16.3	~ 26.5		
C	19.6	~ 31.7		
D	23.5	~ 38.2		
E	28.2	~ 45.8		
F	33.8	~ 55.0		
G	40.6	~ 65.9		
H	48.7	~ 79.1		
I	58.5	~ 95.0		
J	70.2	~ (114.0)		

(Tolerance: ±15%)

(Note 2) Not ask the delivery ratio of each rank.

(Note 3) In case of the distribution of the luminous intensity shift to high, at that point new upper rank is prescribed and lower rank is delete.

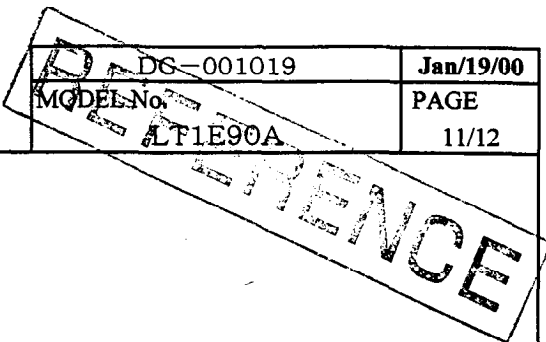

SHARP

7. Soldering

7-1. Reflow soldering

- (1) It is not recommended to exceed the soldering temperature and time shown below. Caused by substrate bend or the other mechanical stress during reflow soldering may happen Au wire disconnection etc. Therefore please check and study your solder reflow machine's best condition.
- (2) Reflow soldering temperature profile to be done under the following condition.

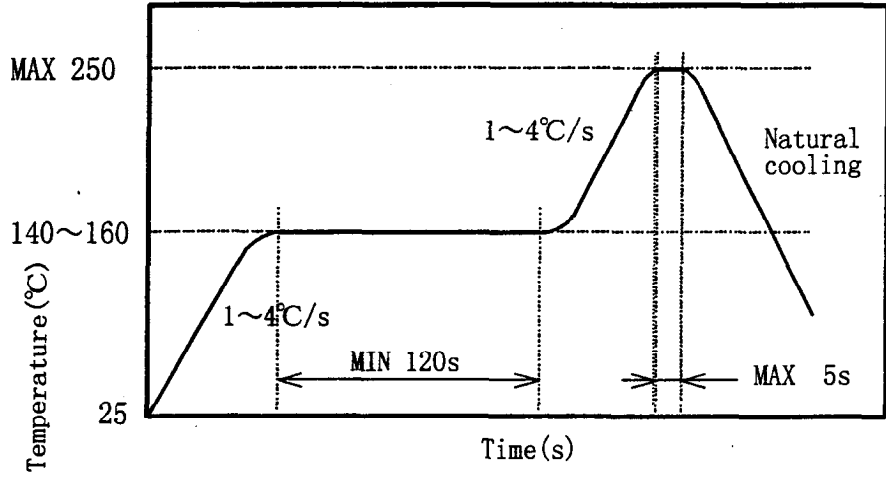

Recommendable Thermal Model

- (3) Recommendable Metal Mask pattern for screen print
 Recommend 0.5mm to 0.7mm thickness metal mask for screen print. Caused by solder reflow condition, solder paste, substrate and the other material etc., may change solderability. Please check and study actual solderability before usage.

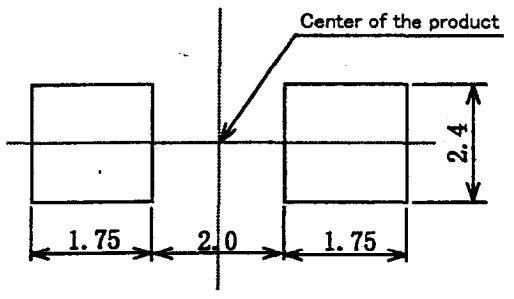

Recommended solder pattern (Unit:mm)

REFERENCE

DG-001019	Jan/19/00
MODEL No. LT1E90A	PAGE 12/12



8. Precautions for use

8-1. Precautions matters for designing circuit

This product is not designed as electromagnetic and ionized-particle radiation resistant.

8-2. Cleaning method

Please use only the following types of solvent. "water"

Recommend conditions: R.T. 40kHz, 30W/l, time is less than 3 minutes

Please check the effect on the product from ultrasonic bath, ultrasonic output, duration, board size method and product mounting

Please test the cleaning method under actual conditions and check for abnormalities before actual use.

9. Environment

9-1. Ozonosphere destructive chemicals.

(1) The product doesn't contain following substance.

(2) The product doesn't have a production line whose process requires following substance.

Restricted part: CFCs,halones,CCl₄, Trichloroethane(Methychloroform)

9-2. Bromic non-burning materials

The product doesn't contain bromic non-burning materials(PBBOs,PBBs)

LT1E90A, surface mount, yellow-green, 3 mm x 3 mm, 670 nm, chip LED