

Fully Sealed Container Cermet Trimmers

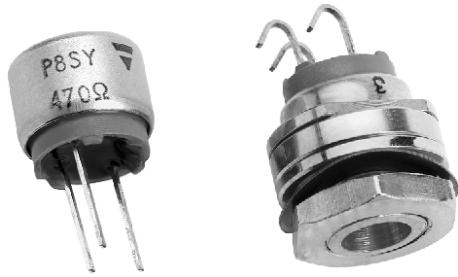

FEATURES

- Industrial grade
- High quality cermet resistive track:
- 1 Watt at 70 °C, P8ST
- 0.5 Watt at 70 °C, P8SX - P8SY
- CECC 41100
- Wide resistance range (10 Ω to 2.2 MΩ)



Three versions are available:

- P8SX, with shaft parallel to the PC board plane
 - P8SY, with shaft perpendicular to the PC board plane
 - P8ST, for front panel mounting
- } Outlets PCB mounting

The P8S series trimmers are extremely well adapted for all industrial applications as their maximum resistance contact variation is within 3 % of R_n and as they are fully sealed.

For more stringent requirements the P8P series is recommended.

DIMENSIONS in millimeters

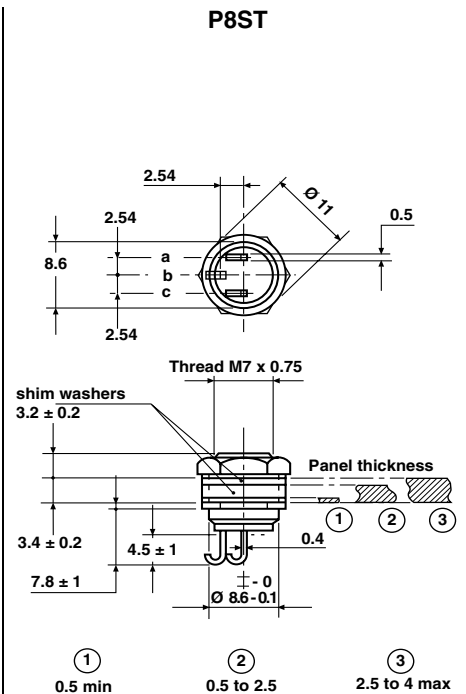
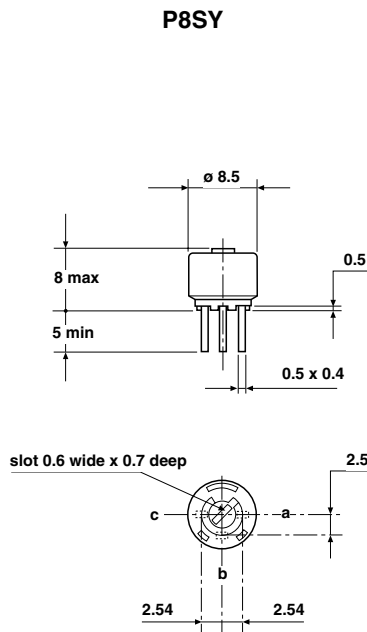
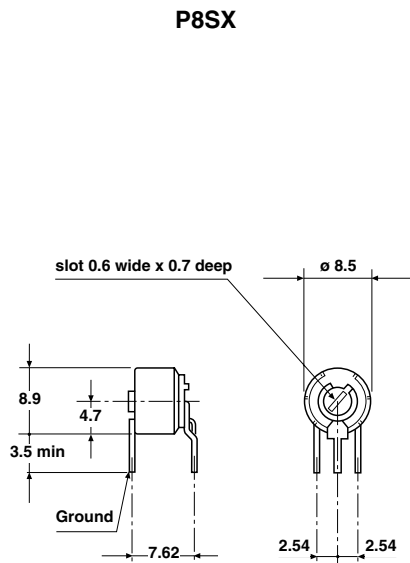

• Tolerance unless otherwise specified: ± 0.5

Consult Vishay Sfernice for panel sealed type

CIRCUIT DIAGRAM

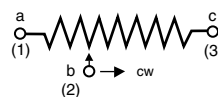



ELECTRICAL SPECIFICATIONS		
Resistive Element		cermet
Electrical Travel		270° ± 15°
Resistance Range		10 Ω to 2.2 MΩ
Standard series E3		1 - 2.2 - 4.7 and on request 1 - 2 - 5
Tolerance	Standard	± 10 %
	On Request	± 5 %
Power Rating	P8SX - P8SY	0.5 W at 70 °C
	P8ST	1 W at 70 °C
Temperature Coefficient		See Standard Resistance Element Table
Limiting Element Voltage (Linear Law)		250 V
Contact Resistance Variation		3 % Rn or 3 Ω
End Resistance (Typical)		1 Ω
Dielectric Strength (RMS)		1000 V
Insulation Resistance (500 VDC)		1 GΩ

MECHANICAL SPECIFICATIONS

Mechanical Travel	300° ± 5°
Operating Torque (max. Ncm)	3
End Stop Torque (max. Ncm)	6
Unit Weight (max. g)	1... 3.1

ENVIRONMENTAL SPECIFICATIONS

Temperature Range	- 55 °C to + 125 °C
Climatic Category	55/125/56
Sealing	fully sealed container IP67

POWER RATING CHART

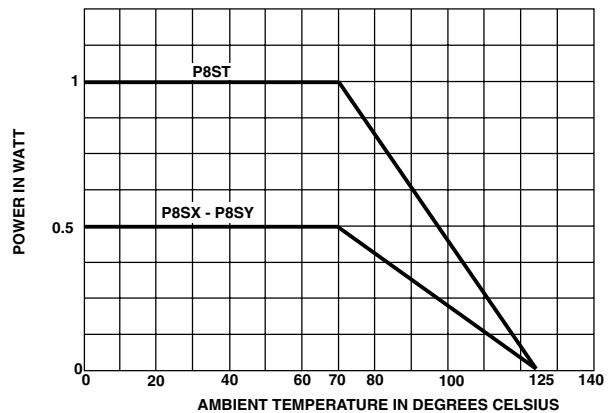

PERFORMANCE			
TESTS	CONDITIONS	TYPICAL VALUES AND DRIFTS	
		$\frac{\Delta RT}{RT}$ (%)	$\frac{\Delta R_{1-2}}{R_{1-2}}$ (%)
Load Life	1000 hours at rated power 90'/30' - ambient temperature 70 °C	± 2 % Contact res. variation: < 3 % Rn	± 3 %
Climatic Sequence	Phase A dry heat 100 °C Phase B damp heat Phase C cold - 55 °C Phase D damp heat 5 cycles	± 0.5 %	± 1 %
Long Term Damp Heat	56 days 40 °C, 93 % RH	± 1 % Dielectric strength: 1000 V RMS Insulation resistance: > 10 ⁴ MΩ	± 2 %
Rapid Temperature Change	5 cycles - 55 °C to + 125 °C	± 0.5 %	$\frac{\Delta V_{1-2}}{V_{1-3}}$ ≤ ± 1 %
Shock	50 g at 11 m secs 3 successive shocks in 3 directions	± 0.2 %	± 0.5 %
Vibration	10 - 55 Hz 0.75 mm or 10 g during 6 hours	± 0.2 %	$\frac{\Delta V_{1-2}}{V_{1-3}}$ ≤ ± 0.5 %
Rotational Life	200 cycles	± 3 % Contact res. variat.: < 3 % Rn	



STANDARD RESISTANCE ELEMENT DATA							
STANDARD RESISTANCE VALUES	P8SX - P8SY			P8ST			TCR - 55 °C +125 °C
	MAX. POWER AT 70 °C	MAX. WORKING VOLTAGE	MAX. CUR. THROUGH WIPER	MAX. POWER AT 70 °C	MAX. WORKING VOLTAGE	MAX. CUR. THROUGH WIPER	
Ω	W	V	mA	W	V	mA	ppm/°C
10	0.5	2.2	224	1	3.16	316	0 + 200
22	↓	3.3	150	↓	4.69	213	
47		4.8	103		6.86	146	
100	↓	7	70	↓	10.0	100	± 100
220		10.5	47		14.8	67	
470		15.3	32		21.7	46	
1K		22.4	22		31.6	32	
2.2K		33.2	15		46.9	21	
4.7K		48.5	10		68.6	15	
10K		70.7	7		100.0	10.0	
22K		105	4.8		148	6.7	
47K		153	3.2		217	4.6	
100K		0.5	224		2.2	0.63	
220K	0.28	250	1.1	0.28	250	1.1	
470K	0.13	250	1.53	0.13	250	0.5	
1M	0.06	250	0.25	0.06	250	0.3	
2.2M	0.028	250	0.11	0.03	250	0.1	

MARKING

- Printed:
- VISHAY trademark
 - series and grade of quality
 - style
 - ohmic value (in Ω , kΩ , MΩ)
 - tolerance (in %)
 - manufacturing date
 - marking of terminal: 3

PACKAGING

- Plastic box of 50 pieces for P8SX and P8SY
- Plastic box of 24 pieces for P8ST

ORDERING INFORMATION

P8 MODEL **SX** STYLE **100 kΩ** OHMIC VALUE **± 10 %** TOLERANCE **BL50** PACKAGING **e2** LEAD FINISH
 P8SX and P8SY: BL50 e2: SnAg alloy
 P8ST: BL24

SAP PART NUMBERING GUIDELINES

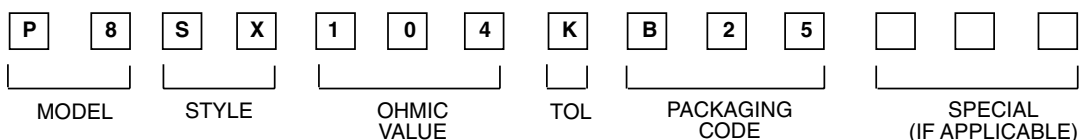

See the end of this data book for conversion tables



Disclaimer

All product specifications and data are subject to change without notice.

Vishay Intertechnology, Inc., its affiliates, agents, and employees, and all persons acting on its or their behalf (collectively, "Vishay"), disclaim any and all liability for any errors, inaccuracies or incompleteness contained herein or in any other disclosure relating to any product.

Vishay disclaims any and all liability arising out of the use or application of any product described herein or of any information provided herein to the maximum extent permitted by law. The product specifications do not expand or otherwise modify Vishay's terms and conditions of purchase, including but not limited to the warranty expressed therein, which apply to these products.

No license, express or implied, by estoppel or otherwise, to any intellectual property rights is granted by this document or by any conduct of Vishay.

The products shown herein are not designed for use in medical, life-saving, or life-sustaining applications unless otherwise expressly indicated. Customers using or selling Vishay products not expressly indicated for use in such applications do so entirely at their own risk and agree to fully indemnify Vishay for any damages arising or resulting from such use or sale. Please contact authorized Vishay personnel to obtain written terms and conditions regarding products designed for such applications.

Product names and markings noted herein may be trademarks of their respective owners.