

Silicon NPN Power Transistors

BU2520DF

DESCRIPTION

- With TO-3PFa package
- High voltage,high speed
- Built-in damper diode

APPLICATIONS

- For use in horizontal deflection circuits of large screen colour TV receivers

PINNING

PIN	DESCRIPTION
1	Base
2	Collector
3	Emitter

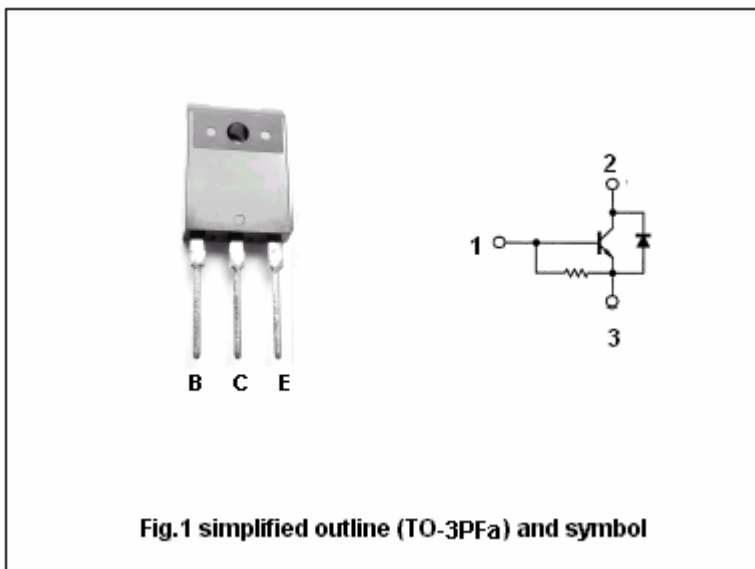

Fig.1 simplified outline (TO-3PFa) and symbol

Absolute maximum ratings(Ta=25)

SYMBOL	PARAMETER	CONDITIONS	VALUE	UNIT
V_{CBO}	Collector-base voltage	Open emitter	1500	V
V_{CEO}	Collector-emitter voltage	Open base	800	V
I_C	Collector current (DC)		10	A
I_{CM}	Collector current-peak		25	A
I_B	Base Collector current (DC)		6	A
I_{BM}	Base current-peak		9	A
P_{tot}	Total power dissipation	$T_C=25$	45	W
T_j	Junction temperature		150	
T_{stg}	Storage temperature		-65~150	

Silicon NPN Power Transistors

BU2520DF

CHARACTERISTICS

T_j=25 unless otherwise specified

SYMBOL	PARAMETER	CONDITIONS	MIN	TYP.	MAX	UNIT
V _{CEO(SUS)}	Collector-emitter sustaining voltage	I _C =100mA ; I _B =0, L=25mH	800			V
V _{(BR)EBO}	Emitter-base breakdown voltage	I _E =600mA ; I _C =0	7.5	13.5		V
V _{CEsat}	Collector-emitter saturation voltage	I _C =6A ; I _B =1.2A			5.0	V
V _{BEsat}	Base-emitter saturation voltage	I _C =6A ; I _B =1.2A			1.1	V
I _{CES}	Collector cut-off current	V _{CE} =BV _{CES} ; V _{BE} =0 T _C =125			1.0 2.0	mA
I _{EBO}	Emitter cut-off current	V _{EB} =7.5V; I _C =0	100		300	mA
h _{FE-1}	DC current gain	I _C =1.0A ; V _{CE} =5V		13		
h _{FE-2}	DC current gain	I _C =6A ; V _{CE} =5V	5	7	9.5	
V _F	Diode forward voltage	I _F =6A			2.2	V
C _C	Collector capacitance	f=1MHz; V _{CB} =10V		115		pF

Silicon NPN Power Transistors

BU2520DF

PACKAGE OUTLINE

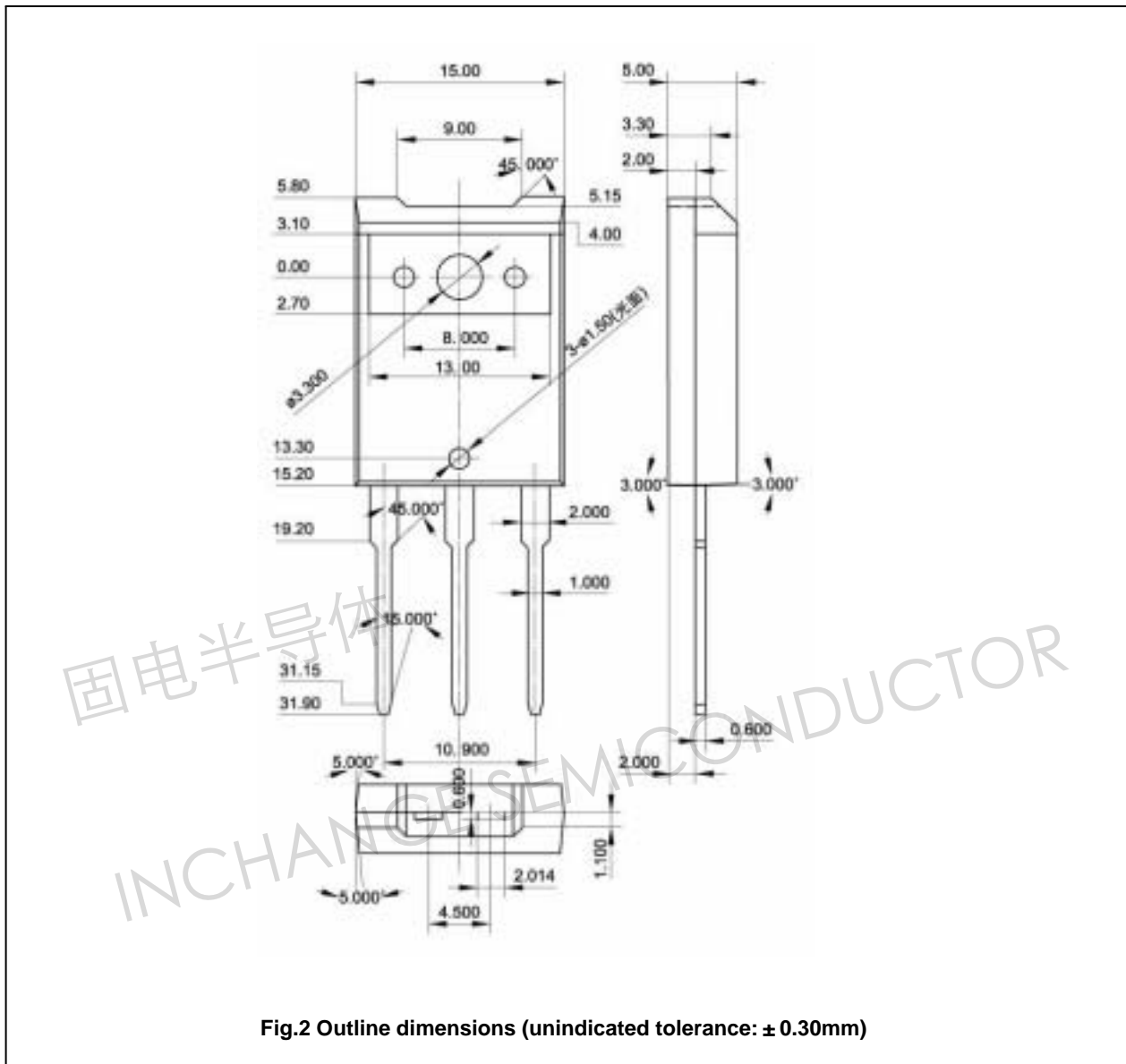

Fig.2 Outline dimensions (unindicated tolerance: ± 0.30mm)