

Silicon NPN Power Transistors

2N3879

DESCRIPTION

- With TO-66 package
- Wide area of safe operation
- High sustaining voltage

APPLICATIONS

- For high-speed switching and linear-amplifier applications

PINNING (See Fig.2)

PIN	DESCRIPTION
1	Base
2	Emitter
3	Collector

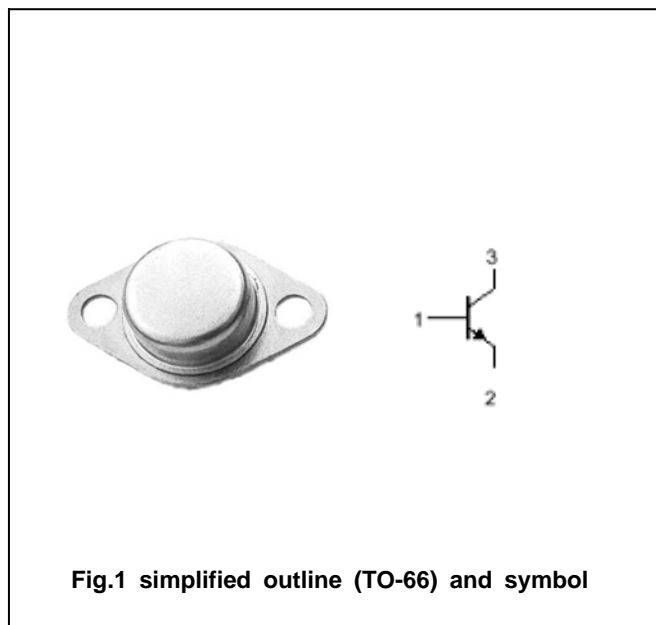

Fig.1 simplified outline (TO-66) and symbol

Absolute maximum ratings($T_a=25^\circ\text{C}$)

SYMBOL	PARAMETER	CONDITIONS	VALUE	UNIT
V_{CBO}	Collector-base voltage	Open emitter	120	V
$V_{CEO(SUS)}$	Collector-emitter sustaining voltage	Open base	75	V
V_{EBO}	Emitter-base voltage	Open collector	7	V
I_C	Collector current		7	A
I_{CM}	Collector current-Peak		10	A
I_B	Base current		5	A
P_T	Total power dissipation	$T_C=25^\circ\text{C}$	35	W
T_j	Junction temperature		200	$^\circ\text{C}$
T_{stg}	Storage temperature		-65~200	$^\circ\text{C}$

THERMAL CHARACTERISTICS

SYMBOL	PARAMETER	MAX	UNIT
$R_{th\ j-c}$	Thermal resistance junction to case	5.0	$^\circ\text{C/W}$

Silicon NPN Power Transistors

2N3879

CHARACTERISTICS

T_j=25°C unless otherwise specified

SYMBOL	PARAMETER	CONDITIONS	MIN	TYP.	MAX	UNIT
V _{CE0(SUS)}	Collector-emitter sustaining voltage	I _C =0.2A ; I _B =0	75			V
V _{CEsat}	Collector-emitter saturation voltage	I _C =4A ; I _B =0.4A			1.2	V
V _{BEsat}	Base-emitter saturation voltage	I _C =4A ; I _B =0.4A			2.0	V
I _{CEV}	Collector cut-off current	V _{CE} =120V ; V _{BE(off)} =1.5V V _{CE} =100V ; V _{BE(off)} =1.5V T _C =150°C			0.5 4.0	mA
I _{CEO}	Collector cut-off current	V _{CE} =40V ; I _B =0			5.0	mA
I _{EBO}	Emitter cut-off current	V _{EB} =7V ; I _C =0			1.0	mA
h _{FE-1}	DC current gain	I _C =4A ; V _{CE} =2V	12		100	
h _{FE-2}	DC current gain	I _C =4A ; V _{CE} =5V	20		80	
h _{FE-3}	DC current gain	I _C =0.5A ; V _{CE} =5V	40			
C _{OB}	Collector output capacitance	I _E =0 ; V _{CB} =10V ; f=1MHz			175	pF

PACKAGE OUTLINE

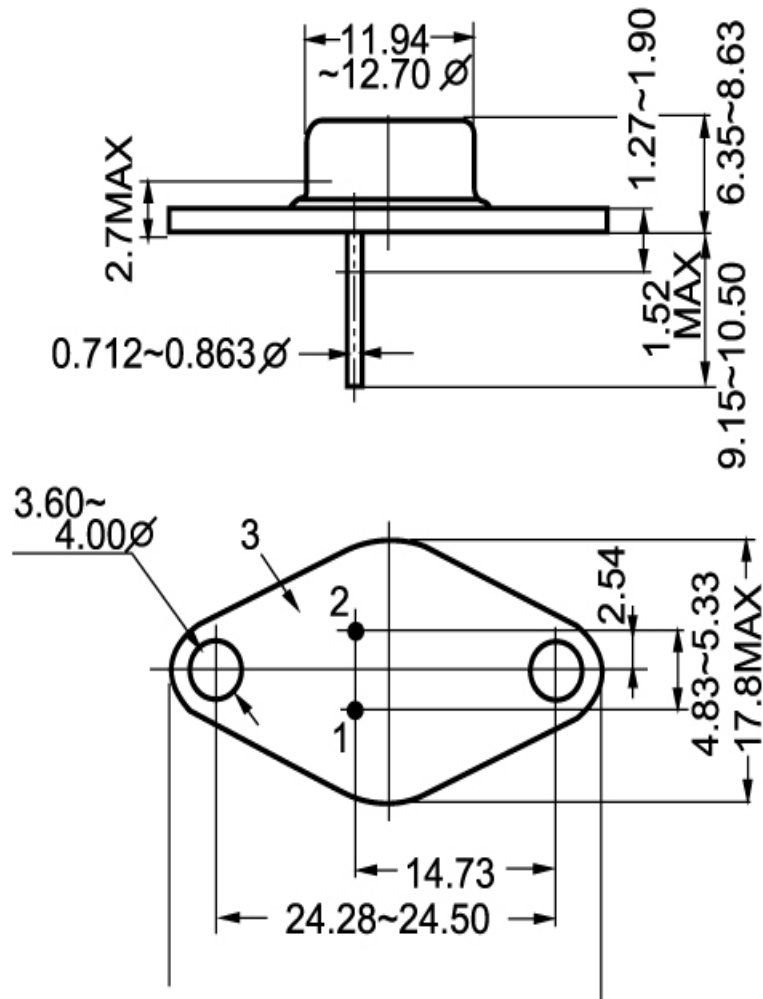

Fig.2 Outline dimensions