

isc Silicon PNP Power Transistor

2SA740

**DESCRIPTION**

- Collector-Emitter Breakdown Voltage  
:  $V_{(BR)CEO} = -150V(\text{Min})$
- DC Current Gain  
:  $h_{FE} = 40-140 @ I_C = -0.5A$
- Complement to Type 2SC1448

**APPLICATIONS**

- Power amplifier applications.
- Vertical output applications.

**ABSOLUTE MAXIMUM RATINGS( $T_a=25^\circ\text{C}$ )**

SYMBOL	PARAMETER	VALUE	UNIT
$V_{CBO}$	Collector-Base Voltage	-150	V
$V_{CEO}$	Collector-Emitter Voltage	-150	V
$V_{EBO}$	Emitter-Base Voltage	-5	V
$I_C$	Collector Current-Continuous	-1.5	A
$I_E$	Emitter Current-Continuous	1.5	A
$P_C$	Total Power Dissipation @ $T_a=25^\circ\text{C}$	1.5	W
	Total Power Dissipation @ $T_C=25^\circ\text{C}$	25	
$T_J$	Junction Temperature	150	$^\circ\text{C}$
$T_{stg}$	Storage Temperature Range	-55~150	$^\circ\text{C}$

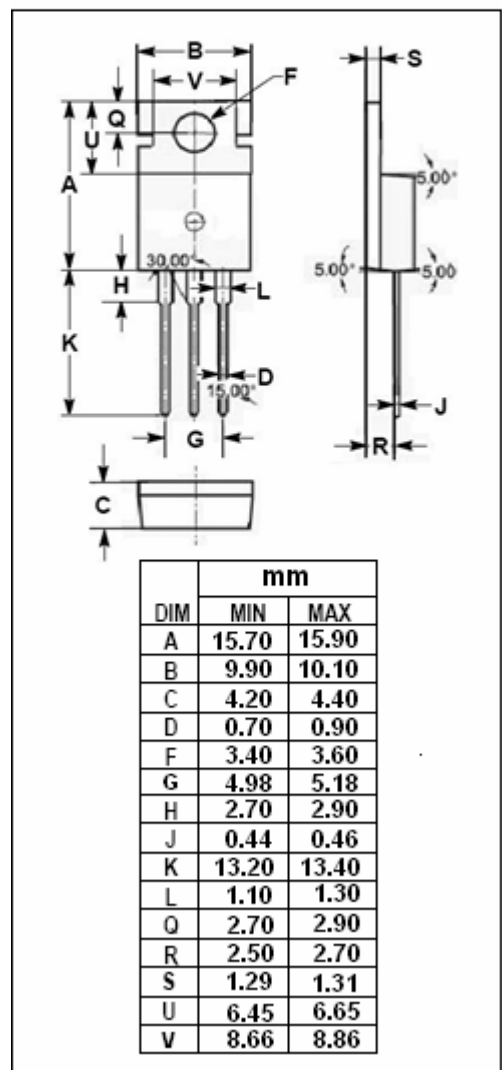
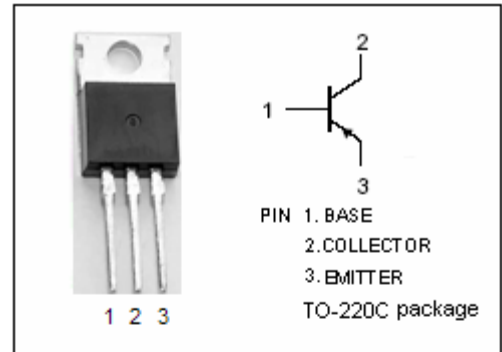

## isc Silicon PNP Power Transistor

2SA740

## ELECTRICAL CHARACTERISTICS

 $T_C=25^\circ\text{C}$  unless otherwise specified

SYMBOL	PARAMETER	CONDITIONS	MIN	TYP.	MAX	UNIT
$V_{(BR)CEO}$	Collector-Emitter Breakdown Voltage	$I_C = -5\text{mA}$ ; $I_B = 0$	-150			V
$V_{(BR)CBO}$	Collector-Base Breakdown Voltage	$I_C = -1\text{mA}$ ; $I_E = 0$	-150			V
$V_{(BR)EBO}$	Emitter-Base Breakdown Voltage	$I_E = -1\text{mA}$ ; $I_C = 0$	-5			V
$V_{CE(sat)}$	Collector-Emitter Saturation Voltage	$I_C = -0.5\text{A}$ ; $I_B = -50\text{mA}$			-1.5	V
$V_{BE(on)}$	Base-Emitter On Voltage	$I_C = -0.5\text{A}$ ; $V_{CE} = -10\text{V}$			-1.0	V
$I_{CBO}$	Collector Cutoff Current	$V_{CB} = -100\text{V}$ ; $I_E = 0$			-20	$\mu\text{A}$
$I_{EBO}$	Emitter Cutoff Current	$V_{EB} = -5\text{V}$ ; $I_C = 0$			-10	$\mu\text{A}$
$h_{FE}$	DC Current Gain	$I_C = -0.5\text{A}$ ; $V_{CE} = -10\text{V}$	40		140	
$C_{OB}$	Output Capacitance	$I_E = 0$ ; $V_{CB} = -10\text{V}$ ; $f_{test} = 1\text{MHz}$		90		pF
$f_T$	Current-Gain—Bandwidth Product	$I_C = -0.5\text{A}$ ; $V_{CE} = -10\text{V}$		8		MHz