

Silicon NPN Power Transistors

2SD1492

DESCRIPTION

- With TO-3PN package
- High voltage ,high reliability
- Wide area of safe operation

APPLICATIONS

- High voltage power switching TV horizontal deflection output applications

PINNING

PIN	DESCRIPTION
1	Base
2	Collector;connected to mounting base
3	Emitter

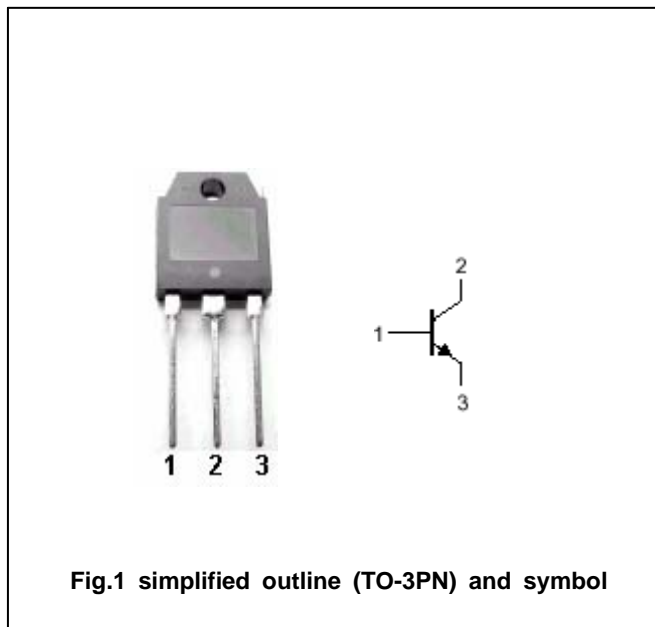

Absolute maximum ratings (Ta=25°C)

SYMBOL	PARAMETER	CONDITIONS	VALUE	UNIT
V_{CBO}	Collector-base voltage	Open emitter	1500	V
V_{CEO}	Collector-emitter voltage	Open base	600	V
V_{EBO}	Emitter-base voltage	Open collector	6	V
I_C	Collector current		1.5	A
P_C	Collector power dissipation	$T_C=25^\circ\text{C}$	50	W
T_j	Junction temperature		150	$^\circ\text{C}$
T_{stg}	Storage temperature		-45~150	$^\circ\text{C}$

Silicon NPN Power Transistors

2SD1492

CHARACTERISTICS

T_j=25°C unless otherwise specified

SYMBOL	PARAMETER	CONDITIONS	MIN	TYP.	MAX	UNIT
V _{(BR)EBO}	Emitter-base breakdown voltage	I _E =10mA; I _C =0	6			V
V _{(BR)CEO}	Collector-emitter breakdown voltage	I _C =10mA; R _{BE} =∞	600			V
V _{CEsat}	Collector-emitter saturation voltage	I _C =1.2A; I _B =0.3A			5.0	V
V _{BEsat}	Base-emitter saturation voltage	I _C =1.2A; I _B =0.3A			1.5	V
I _{CEX}	Collector cut-off current	V _{CE} =1500V; V _{BE} =1.5V			1.0	mA
I _{EBO}	Emitter cut-off current	V _{EB} =6V; I _C =0			1.0	mA
h _{FE}	DC current gain	I _C =0.3A ; V _{CE} =5V	10		30	

Silicon NPN Power Transistors

2SD1492

PACKAGE OUTLINE

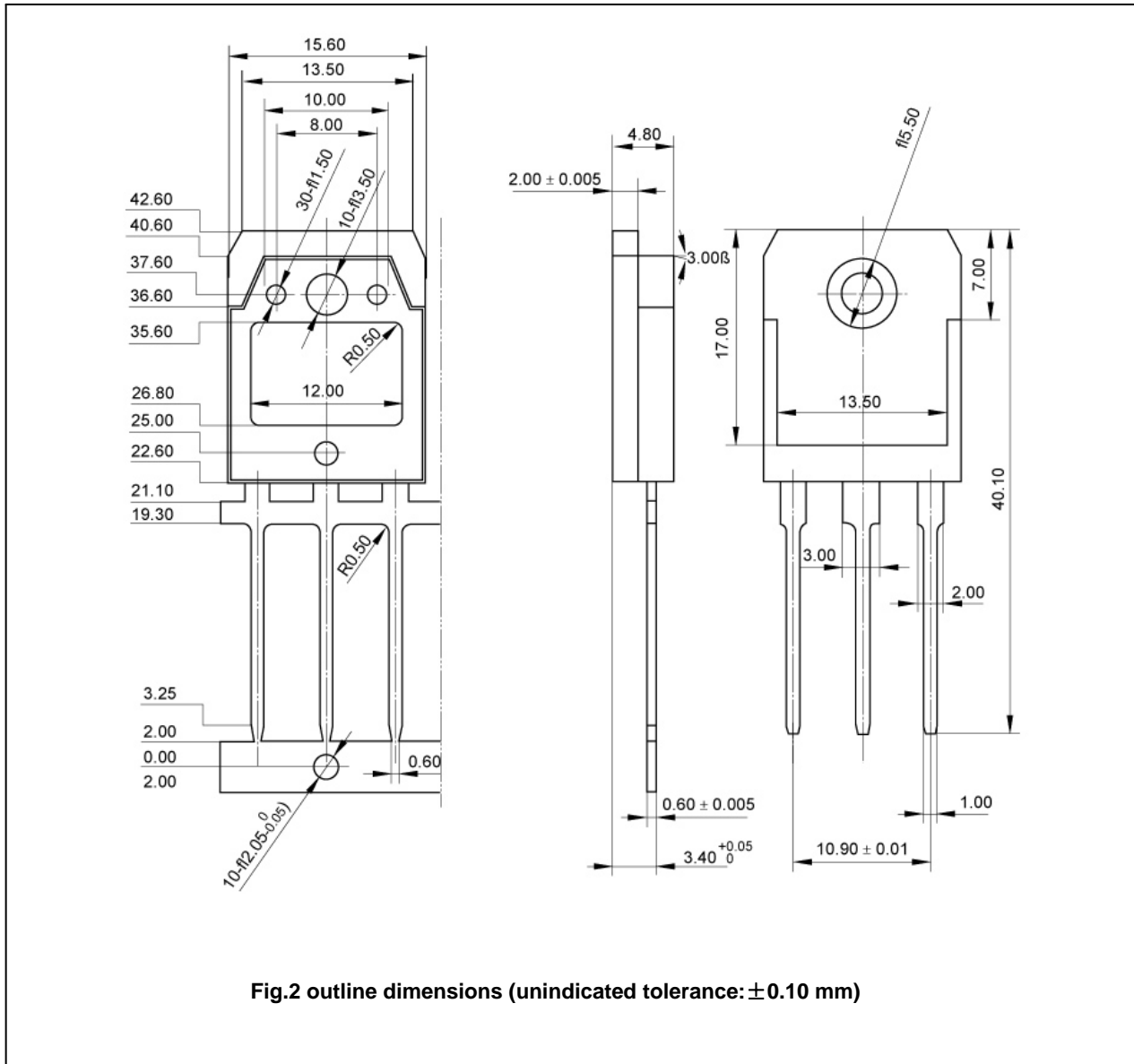

Fig.2 outline dimensions (unindicated tolerance: ± 0.10 mm)