

Silicon PNP Darlington Power Transistors

2SB1255

DESCRIPTION

- With TO-3PFa package
- Optimum for 90W Hi-Fi output
- High forward current transfer ratio h_{FE}
- Low collector-emitter saturation voltage
- Complement to type 2SD1895

APPLICATIONS

- Power amplification

PINNING

PIN	DESCRIPTION
1	Base
2	Collector
3	Emitter

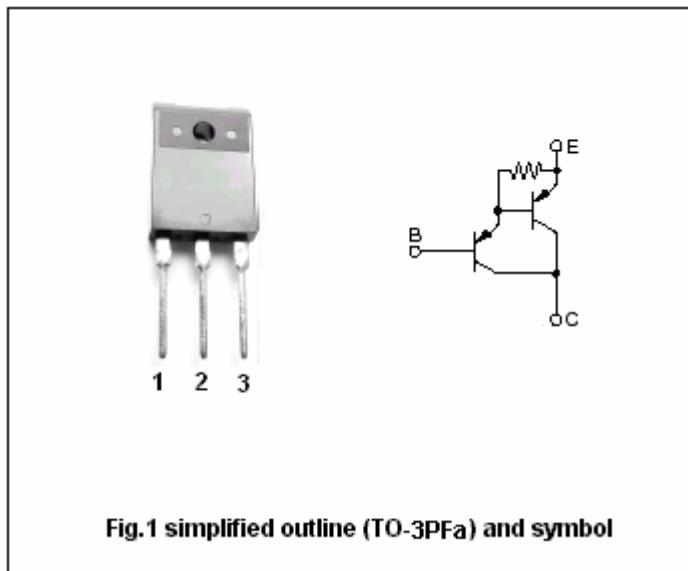

Absolute maximum ratings(Ta=25°C)

SYMBOL	PARAMETER	CONDITIONS	VALUE	UNIT
V_{CBO}	Collector-base voltage	Open emitter	-160	V
V_{CEO}	Collector-emitter voltage	Open base	-140	V
V_{EBO}	Emitter-base voltage	Open collector	-8	V
I_C	Collector current		-15	A
I_{CP}	Collector current-peak		-12	A
P_C	Collector power dissipation	$T_C=25^\circ C$	100	W
			3	
T_j	Junction temperature		150	°C
T_{stg}	Storage temperature		-55~150	°C

Silicon PNP Darlington Power Transistors

2SB1255

CHARACTERISTICS

T_j=25°C unless otherwise specified

SYMBOL	PARAMETER	CONDITIONS	MIN	TYP.	MAX	UNIT
V _{CEO}	Collector-emitter voltage	I _C =-30mA ; I _B =0	-140			V
V _{CEsat}	Collector-emitter saturation voltage	I _C =-7A ; I _B =-7mA			-2.5	V
V _{BEsat}	Base-emitter saturation voltage	I _C =-7A ; I _B =-7mA			-3.0	V
I _{CBO}	Collector cut-off current	V _{CB} =-160V ; I _E =0			-100	μA
I _{CEO}	Collector cut-off current	V _{CE} =-140V ; I _B =0			-100	μA
I _{EBO}	Emitter cut-off current	V _{EB} =-5V ; I _C =0			-100	μA
h _{FE-1}	DC current gain	I _C =-1A ; V _{CE} =-5V	2000			
h _{FE-2}	DC current gain	I _C =-7A ; V _{CE} =-5V	5000		30000	
f _T	Transition frequency	I _C =0.5A ; V _{CE} =-10V ; f=1MHz		20		MHz

Switching times

t _{on}	Turn-on time	I _C =-7A ; V _{CC} =-50V I _{B1} =-I _{B2} =-7mA		1.0		μs
t _{stg}	Storage time			1.5		μs
t _f	Fall time			1.2		μs

◆ h_{FE-2} classifications

Q	P
5000-15000	8000-30000

Silicon PNP Darlington Power Transistors

2SB1255

PACKAGE OUTLINE

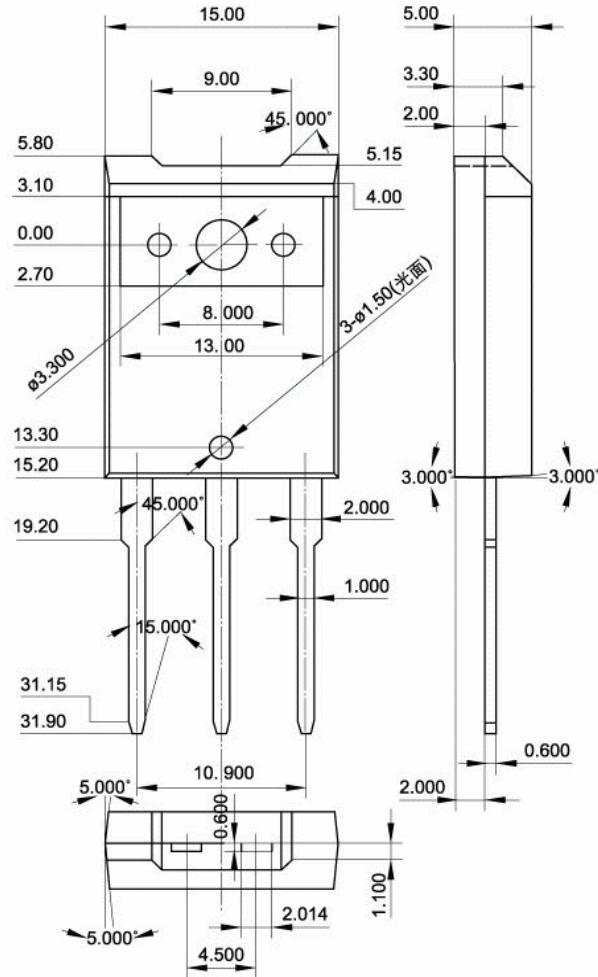

Fig.2 Outline dimensions (unindicated tolerance:±0.30mm)