

# UNIDIRECTIONAL INTEGRATED TAP MONITOR ARRAY

## UTMA Series

### Product Description

Oplink's Unidirectional Integrated Tap Monitor Array (UTMA) is assembled using individual Unidirectional Integrated Tap Monitor (UTMS) to guarantee no optical or electrical cross-talk among different channels. UTMS is a hybrid component that integrates a flat spectral response of a thin-film tap with a high sensitivity PIN photodiode for power monitoring applications. The Unidirectional feature allows power monitoring from input port only. UTMA minimizes component assembly costs and module footprint while increasing module design efficiency by facilitating fiber management.

Each UTMS in the UTMA integrates the functionality of an optical coupler and a photodiode while delivering low insertion loss and low dark current with high temperature stability over a wide wavelength range. It is compact and easy to mount on a PCB board for module and network system use. Applications include DWDM channel power monitoring, optical network switching/protection monitoring, re-configurable optical add/drop multiplexers, and gain/attenuation monitoring in amplifier systems.

Oplink can provide customized designs to meet specialized feature applications. Also, Oplink offers modular assemblies that integrate other components to form a full function module or subsystem.



### Performance Specification

Parameter		Specification		Units
Operating Wavelength Range		1260 ~ 1360	1510 ~ 1610	nm
Through	Insertion Loss (@λ <sub>op</sub> , Top, All SOP, Exclude Connectors) <sup>1</sup>	2%	≤0.5	dB
		5%	≤0.7	dB
		10%	≤1.0	dB
	Polarization Dependent Loss	≤0.1		dB
Return Loss (exclude connector)		≥45		dB
Tapped Monitoring	Responsivity (Relative to Nominal Power at Input Port)	2%	10~23	mA/W
		5%	26~59	mA/W
		10%	52~110	mA/W
	Responsivity Polarization Dependence	≤0.15		dB
Directivity <sup>1</sup>		≥33		dB
PD	PD Dark Current (@ -5V bias, 70°C)		≤ 5	nA
	Bandwidth (50 ohm, 5V, -3dB)		≤ 1	nA
	Reverse Voltage		≤20	V
	Forward Current		≤ 5	mA
Conditions	Input Optical Power	2%	≤21	dBm
		5%	≤16	dBm
		10%	≤12	dBm
	Operating Temperature Range (<85%RH, Non-condensing)		0	70
Storage Temperature Range (<85%RH, Non-condensing)		-40	85	°C
Fiber Type		SMF-28		

1. Directivity is defined as  $-10\log(\mathfrak{R}_{out \rightarrow PD} / \mathfrak{R}_{in \rightarrow PD})$  where  $\mathfrak{R}$  stands for responsivity

### Features

- ◆ Flat and Broad Operating Wavelength Range
- ◆ Low Insertion Loss and PDL
- ◆ Low Dark Current
- ◆ Various Tap Ratio Available
- ◆ High Temperature Stability with Hermetically Sealed Photodiode
- ◆ Monitor Optical Signal from One Direction Only

### Applications

- ◆ EDFA and Raman Amplifiers
- ◆ Add/Drop and Optical Protection Monitoring
- ◆ DWDM/CWDM Systems

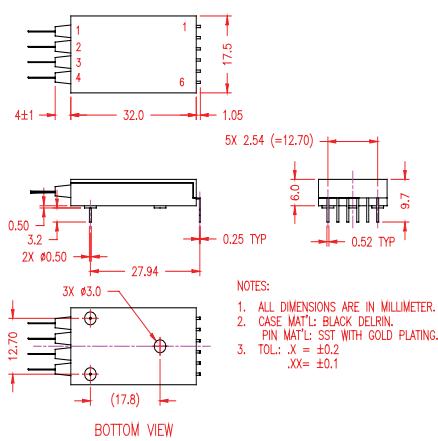
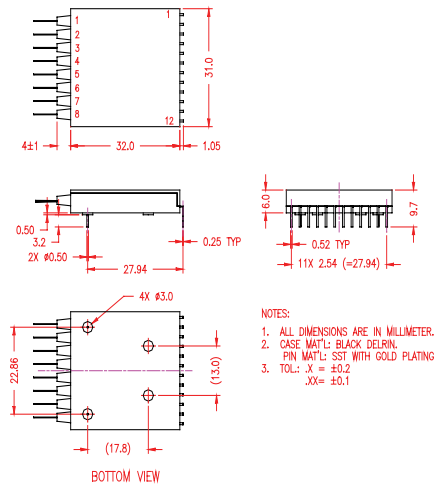
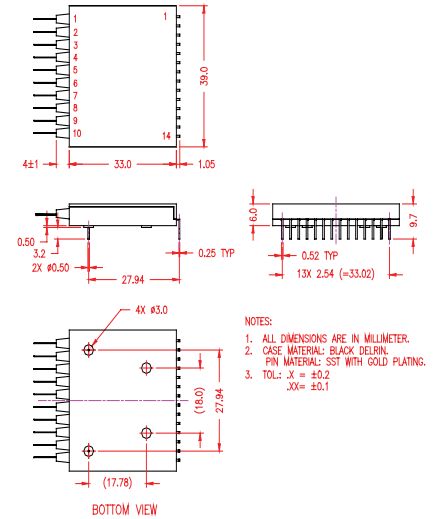
**Mechanical Drawing / Package Dimensions (dimension in mm)**
**1) 4-ch UTMA**

**2) 8-ch UTMA**

**3) 10-ch UTMA**

**Electrical Pin Assignment**

Pin#:	Common Cathode Assignment	Common Anode Assignment
Pin1:	Common Cathode for Ch1 & 2	Common Anode for Ch1 & 2
Pin2:	Anode Ch1	Cathode Ch1
Pin3:	Anode Ch2	Cathode Ch2
Pin4:	Common Cathode for Ch3 & 4	Common Anode for Ch3 & 4
Pin5:	Anode Ch3	Cathode Ch3
Pin6:	Anode Ch4	Cathode Ch4

**Electrical Pin Assignment**

Pin#:	Common Cathode Assignment	Common Anode Assignment
Pin1:	Common Cathode for Ch1 & 2	Common Anode for Ch1 & 2
Pin2:	Anode Ch1	Cathode Ch1
Pin3:	Anode Ch2	Cathode Ch2
Pin4:	Common Cathode for Ch3 & 4	Common Anode for Ch3 & 4
Pin5:	Anode Ch3	Cathode Ch3
Pin6:	Anode Ch4	Cathode Ch4
Pin7:	Anode Ch5	Cathode Ch5
Pin8:	Common Cathode for Ch5 & 6	Common Anode for Ch5 & 6
Pin9:	Anode Ch6	Cathode Ch6
Pin10:	Anode Ch7	Cathode Ch7
Pin11:	Common Cathode for Ch7 & 8	Common Anode for Ch7 & 8
Pin12:	Anode Ch8	Cathode Ch8

**Electrical Pin Assignment**

Pin#:	Common Cathode Assignment	Common Anode Assignment
Pin1:	Common Cathode for Ch1 to 4	Common Anode for Ch1 to 4
Pin2:	Anode Ch1	Cathode Ch1
Pin3:	Anode Ch2	Cathode Ch2
Pin4:	Anode Ch3	Cathode Ch3
Pin5:	Anode Ch4	Cathode Ch4
Pin6:	Anode Ch5	Cathode Ch5
Pin7:	Common Cathode for Ch5 to 8	Common Anode for Ch5 to 8
Pin8:	Anode Ch6	Cathode Ch6
Pin9:	Anode Ch7	Cathode Ch7
Pin10:	Anode Ch8	Cathode Ch8
Pin11:	Anode Ch9	Cathode Ch9
Pin12:	Common Cathode for Ch9 & 10	Common Anode for Ch9 & 10
Pin13:	Anode Ch10	Cathode Ch10
Pin14:	Not connected	Not connected

**Ordering Information**

Oplink can provide a remarkable range of customized optical solutions. For detail, please contact Oplink's OEM design team or account manager for your requirements and ordering information (510) 933-7200.

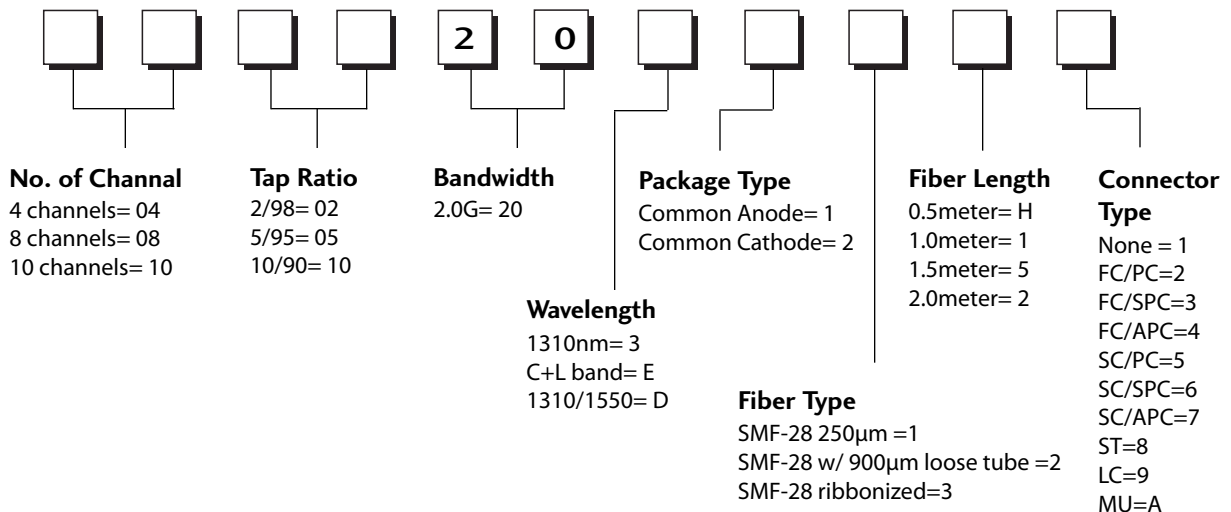
**UTMA**

**RoHS:**

- UTMA is RoHS 5 compliant (RoHS permitted Lead in solder exemption is applied).
- Add "G" to the end of the above PN for RoHS 6 Requirement.