

### DESCRIPTION

The 3850 group (spec. A) is the 8-bit microcomputer based on the 740 family core technology.

The 3850 group (spec. A) is designed for the household products and office automation equipment and includes serial interface functions, 8-bit timer, and A/D converter.

### FEATURES

- Basic machine-language instructions ..... 71
- Minimum instruction execution time ..... 0.32  $\mu$ s  
(at 12.5 MHz oscillation frequency)
- Memory size
  - ROM ..... 8K to 32K bytes
  - RAM ..... 512 to 1K bytes
- Programmable input/output ports ..... 34
- On-chip software pull-up resistor
- Interrupts ..... 15 sources, 14 vectors
- Timers ..... 8-bit X 4
- Serial interface
  - Serial I/O1 ..... 8-bit X 1 (UART or Clock-synchronized)
  - Serial I/O2 ..... 8-bit X 1 (Clock-synchronized)
- PWM ..... 8-bit X 1
- A/D converter ..... 10-bit X 9 channels
- Watchdog timer ..... 16-bit X 1

- Clock generating circuit ..... Built-in 2 circuits  
(connect to external ceramic resonator or quartz-crystal oscillator)
- Power source voltage
  - In high-speed mode ..... 4.0 to 5.5 V  
(at 12.5 MHz oscillation frequency)
  - In high-speed mode ..... 2.7 to 5.5 V  
(at 6 MHz oscillation frequency)
  - In middle-speed mode ..... 2.7 to 5.5 V  
(at 12.5 MHz oscillation frequency)
  - In low-speed mode ..... 2.7 to 5.5 V  
(at 32 kHz oscillation frequency)
- Power dissipation
  - In high-speed mode
    - Except M38507F8AFP/SP ..... 32.5mW
    - M38507F8AFP/SP ..... 37.5mW  
(at 12.5 MHz oscillation frequency, at 5 V power source voltage)
  - In low-speed mode
    - Except M38507F8AFP/SP ..... 60  $\mu$ W
    - M38507F8AFP/SP ..... 450  $\mu$ W  
(at 32 kHz oscillation frequency, at 3 V power source voltage)
- Operating temperature range ..... -20 to 85°C

### APPLICATION

Office automation equipment, FA equipment, Household products, Consumer electronics, etc.

### PIN CONFIGURATION (TOP VIEW)

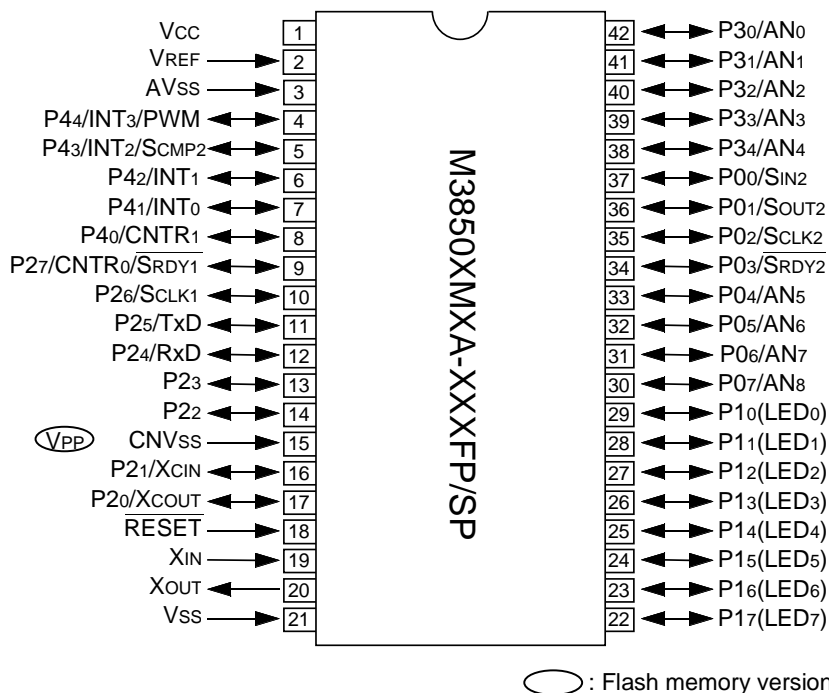

Package type : FP ..... PRSP0042GA-B (42P2R-A/E) (42-pin plastic-molded SSOP)  
 Package type : SP ..... PRDP0042BA-A (42P4B) (42-pin plastic-molded SDIP)

Fig. 1 M3850MXA-XXXFP/SP pin configuration

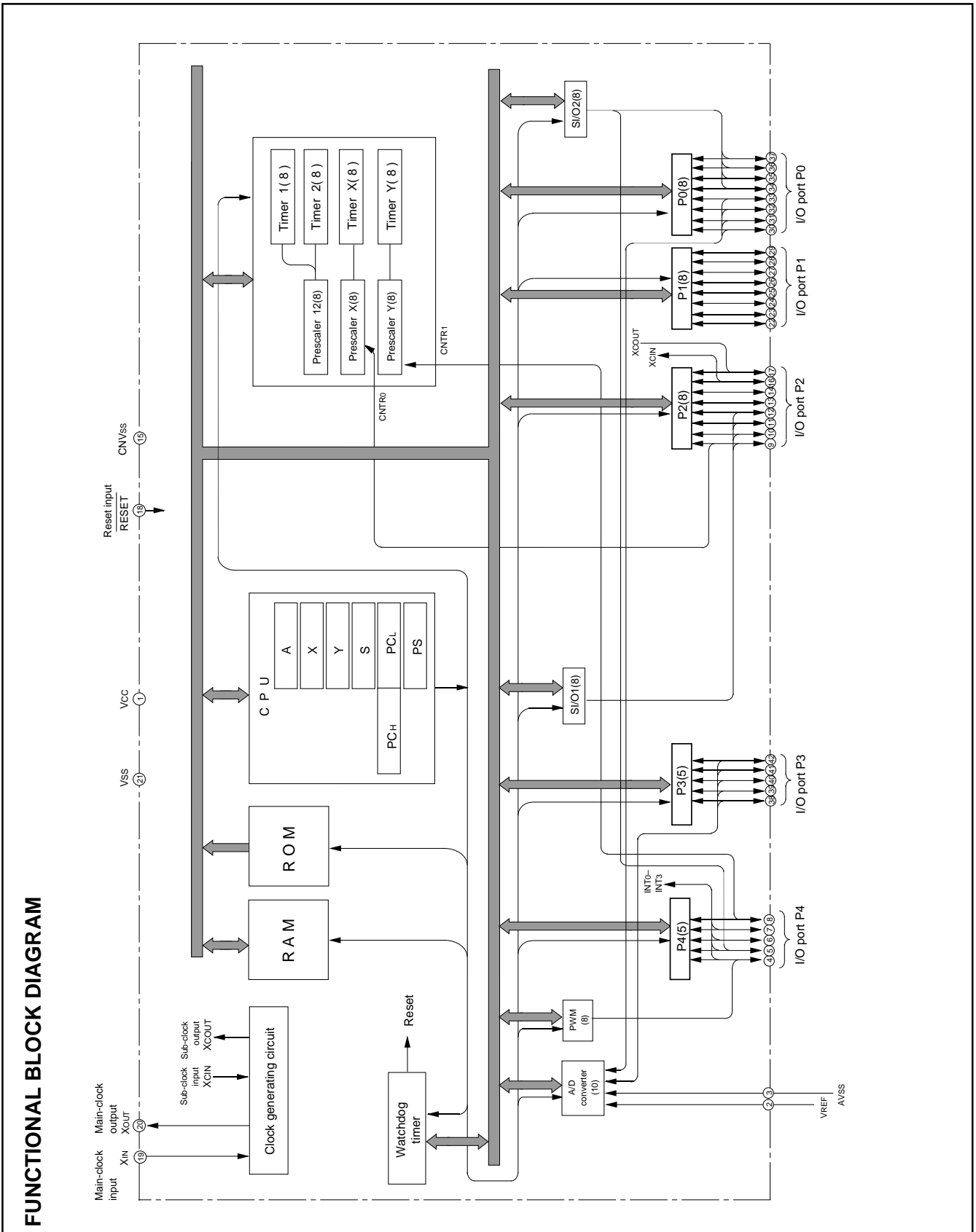

Fig. 2 Functional block diagram

Table 1 Pin description

Pin	Name	Functions	
			Function except a port function
VCC, VSS	Power source	•Apply voltage of 2.7 V – 5.5 V to Vcc, and 0 V to Vss.	
CNVSS	CNVSS input	•This pin controls the operation mode of the chip. •Normally connected to Vss.	
VREF	Reference voltage	•Reference voltage input pin for A/D converter.	
AVSS	Analog power source	•Analog power source input pin for A/D converter. •Connect to Vss.	
RESET	Reset input	•Reset input pin for active “L”.	
XIN	Clock input	•Input and output pins for the clock generating circuit. •Connect a ceramic resonator or quartz-crystal oscillator between the XIN and XOUT pins to set the oscillation frequency.	
XOUT	Clock output	•When an external clock is used, connect the clock source to the XIN pin and leave the XOUT pin open.	
P00/SIN2 P01/SOUT2 P02/SCLK2 P03/SRDY2	I/O port P0	•8-bit CMOS I/O port. •I/O direction register allows each pin to be individually programmed as either input or output. •CMOS compatible input level. •CMOS 3-state output structure. •Pull-up control is enabled in a byte unit.	• Serial I/O2 function pin
P04/AN5–P07/AN8			• A/D converter input pin
P10–P17	I/O port P1	•P10 to P17 (8 bits) are enabled to output large current for LED drive.	
P20/XCOU P21/XCIN	I/O port P2	•8-bit CMOS I/O port. •I/O direction register allows each pin to be individually programmed as either input or output. •CMOS compatible input level.	• Sub-clock generating circuit I/O pins (connect a resonator)
P22 P23		•P20, P21, P24 to P27: CMOS3-state output structure. •P22, P23: N-channel open-drain structure.	• Serial I/O1 function pin
P24/RxD P25/TxD P26/SCLK1		•Pull-up control of P20, P21, P24–P27 is enabled in a byte unit.	• Serial I/O1 function pin/ Timer X function pin
P27/CNTR0/ SRDY1			
P30/AN0– P34/AN4	I/O port P3	•5-bit CMOS I/O port with the same function as port P0. •CMOS compatible input level. •CMOS 3-state output structure. •Pull-up control is enabled in a bit unit.	
P40/CNTR1	I/O port P4	•5-bit CMOS I/O port with the same function as port P0. •CMOS compatible input level. •CMOS 3-state output structure. •Pull-up control is enabled in a bit unit.	• Timer Y function pin • Interrupt input pins
P41/INT0 P42/INT1			• Interrupt input pin • SCMP2 output pin
P43/INT2/SCMP2			• Interrupt input pin • PWM output pin
P44/INT3/PWM			

### PART NUMBERING

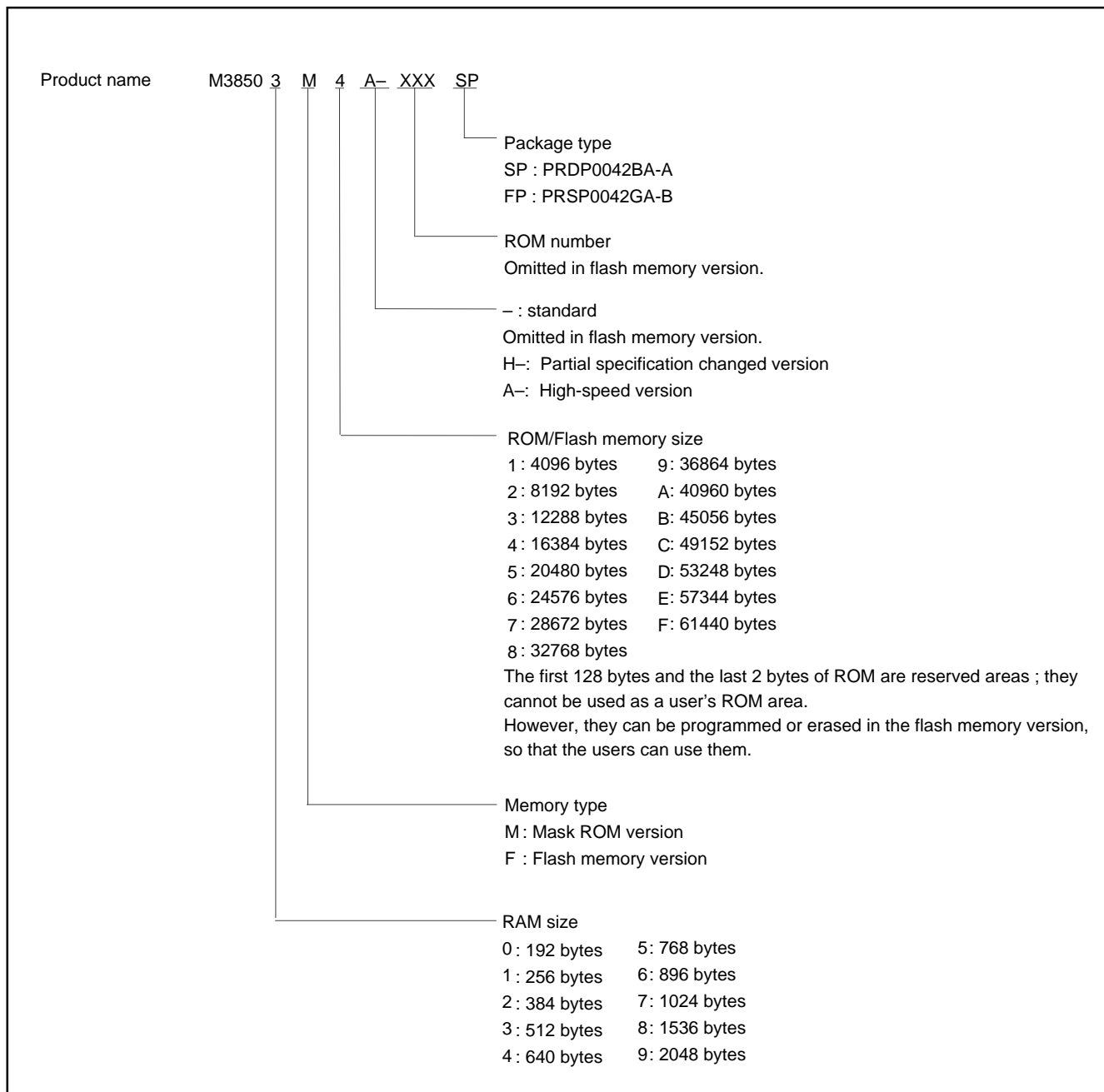

Fig. 3 Part numbering

**GROUP EXPANSION**

Renesas Technology expands the 3850 group (spec.A) as follows.

**Packages**

PRDP0042BA-A ..... 42-pin shrink plastic-molded DIP  
 PRSP0042GA-B ..... 42-pin plastic-molded SOP

**Memory Type**

Support for mask ROM and flash memory versions.

**Memory Size**

Flash memory size ..... 32 K bytes  
 Mask ROM size ..... 8 K to 32 K bytes  
 RAM size ..... 512 to 1 K bytes

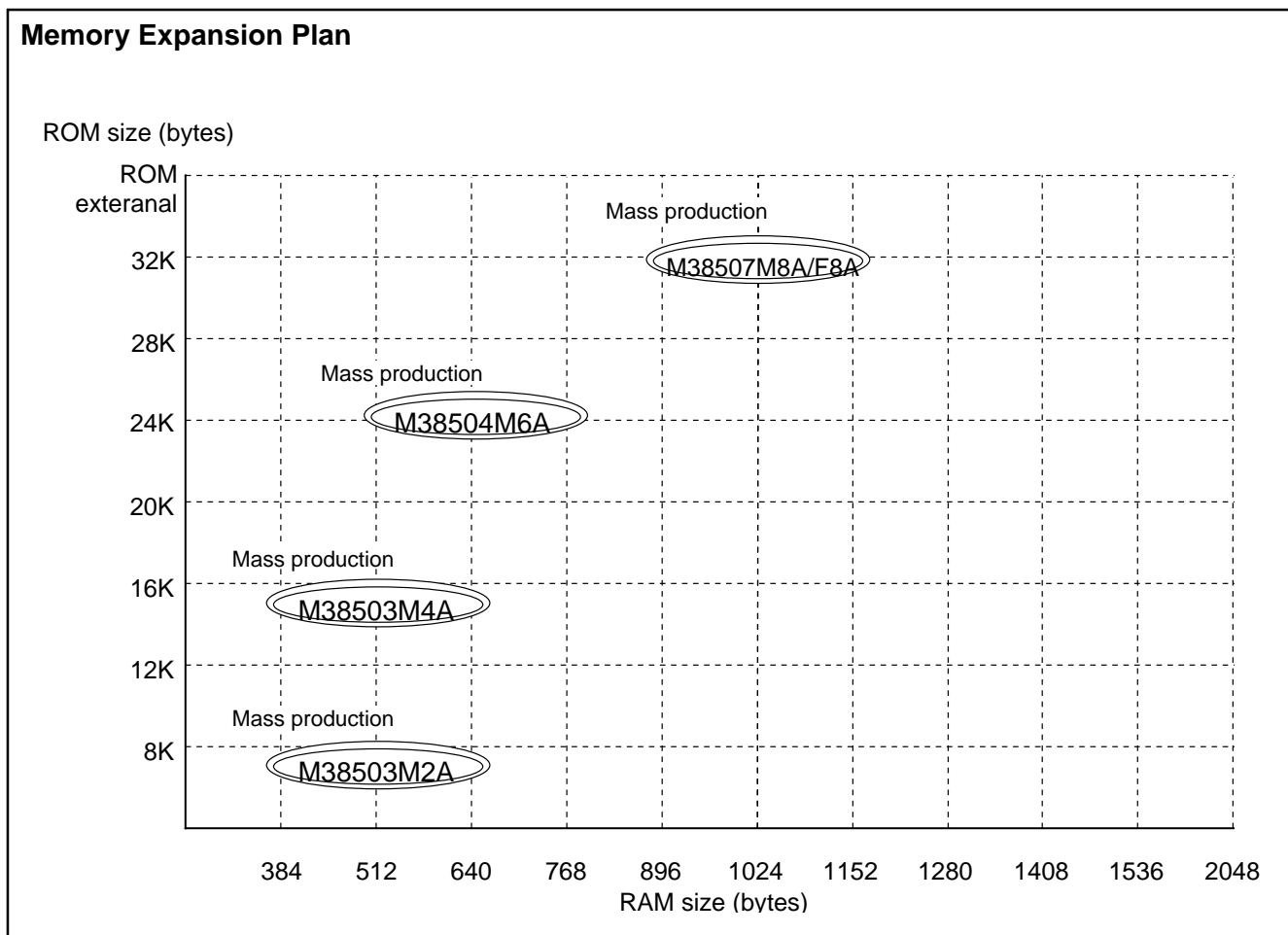

Fig. 4 Memory expansion plan

Currently planning products are listed below.

**Table 2 Support products (spec. A)**

Product name	ROM size (bytes) ROM size for User in ( )	RAM size (bytes)	Package	Remarks
M38503M2A-XXXSP	8192 (8062)	512	PRDP0042BA-A	Mask ROM version
M38503M2A-XXXFP			PRSP0042GA-B	Mask ROM version
M38503M4A-XXXSP	16384 (16254)	512	PRDP0042BA-A	Mask ROM version
M38503M4A-XXXFP			PRSP0042GA-B	Mask ROM version
M38504M6A-XXXSP	24576 (24446)	640	PRDP0042BA-A	Mask ROM version
M38504M6A-XXXFP			PRSP0042GA-B	
M38507F8ASP	32768	1024	PRDP0042BA-A	Flash memory version
M38507F8AFP			PRSP0042GA-B	
M38507M8A-XXXSP	32768 (32635)	1024	PRDP0042BA-A	Mask ROM version
M38507M8A-XXXFP			PRSP0042GA-B	

**Table 3 Differences among 3850 group (standard), 3850 group (spec. H), and 3850 group (spec. A)**

	3850 group (standard)	3850 group (spec. H)	3850 group (spec. A)
Serial interface	1: Serial I/O (UART or Clock-synchronized)	2: Serial I/O1 (UART or Clock-synchronized) Serial I/O2 (Clock-synchronized)	2: Serial I/O1 (UART or Clock-synchronized) Serial I/O2 (Clock-synchronized)
A/D converter	Unserviceable in low-speed mode Analog channel..... 5	Serviceable in low-speed mode Analog channel..... 5	Serviceable in low-speed mode Analog channel..... 9
Large current port	5: P13–P17	8: P10–P17	8: P10–P17
Software pull-up resistor	Not available	Not available	Built-in (Port P0–P4)
Maximum operating frequency	8 MHz	8 MHz	12.5 MHz

### Notes on differences among 3850 group (standard), 3850 group (spec. H), and 3850 group (spec. A)

- (1) The absolute maximum ratings of 3850 group (spec. A) is smaller than that of 3850 group (standard).
  - Power source voltage  $V_{CC} = -0.3$  to 6.5 V
  - CNVss input voltage  $V_I = -0.3$  to  $V_{CC} + 0.3$  V
- (2) The oscillation circuit constants of XIN-XOUT, XCIN-XCOUT may be some differences among 3850 group (standard), 3850 group (spec. H), and 3850 group (spec. A).
- (3) Do not write any data to the reserved area and the reserved bit. (Do not change the contents after reset.)
- (4) Fix bit 3 of the CPU mode register to "1".
- (5) Be sure to perform the termination of unused pins.

## FUNCTIONAL DESCRIPTION CENTRAL PROCESSING UNIT (CPU)

The 3850 group (spec. A) uses the standard 740 Family instruction set. Refer to the table of 740 Family addressing modes and machine instructions or the 740 Family Software Manual for details on the instruction set.

Machine-resident 740 Family instructions are as follows:

- The FST and SLW instructions cannot be used.
- The STP, WIT, MUL, and DIV instructions can be used.

### [Accumulator (A)]

The accumulator is an 8-bit register. Data operations such as data transfer, etc., are executed mainly through the accumulator.

### [Index Register X (X)]

The index register X is an 8-bit register. In the index addressing modes, the value of the OPERAND is added to the contents of register X and specifies the real address.

### [Index Register Y (Y)]

The index register Y is an 8-bit register. In partial instruction, the value of the OPERAND is added to the contents of register Y and specifies the real address.

### [Stack Pointer (S)]

The stack pointer is an 8-bit register used during subroutine calls and interrupts. This register indicates start address of stored area (stack) for storing registers during subroutine calls and interrupts. The low-order 8 bits of the stack address are determined by the contents of the stack pointer. The high-order 8 bits of the stack address are determined by the stack page selection bit. If the stack page selection bit is "0", the high-order 8 bits becomes "0016". If the stack page selection bit is "1", the high-order 8 bits becomes "0116".

The operations of pushing register contents onto the stack and popping them from the stack are shown in Figure 6.

Store registers other than those described in Figure 6 with program when the user needs them during interrupts or subroutine calls.

### [Program Counter (PC)]

The program counter is a 16-bit counter consisting of two 8-bit registers PCH and PCL. It is used to indicate the address of the next instruction to be executed.

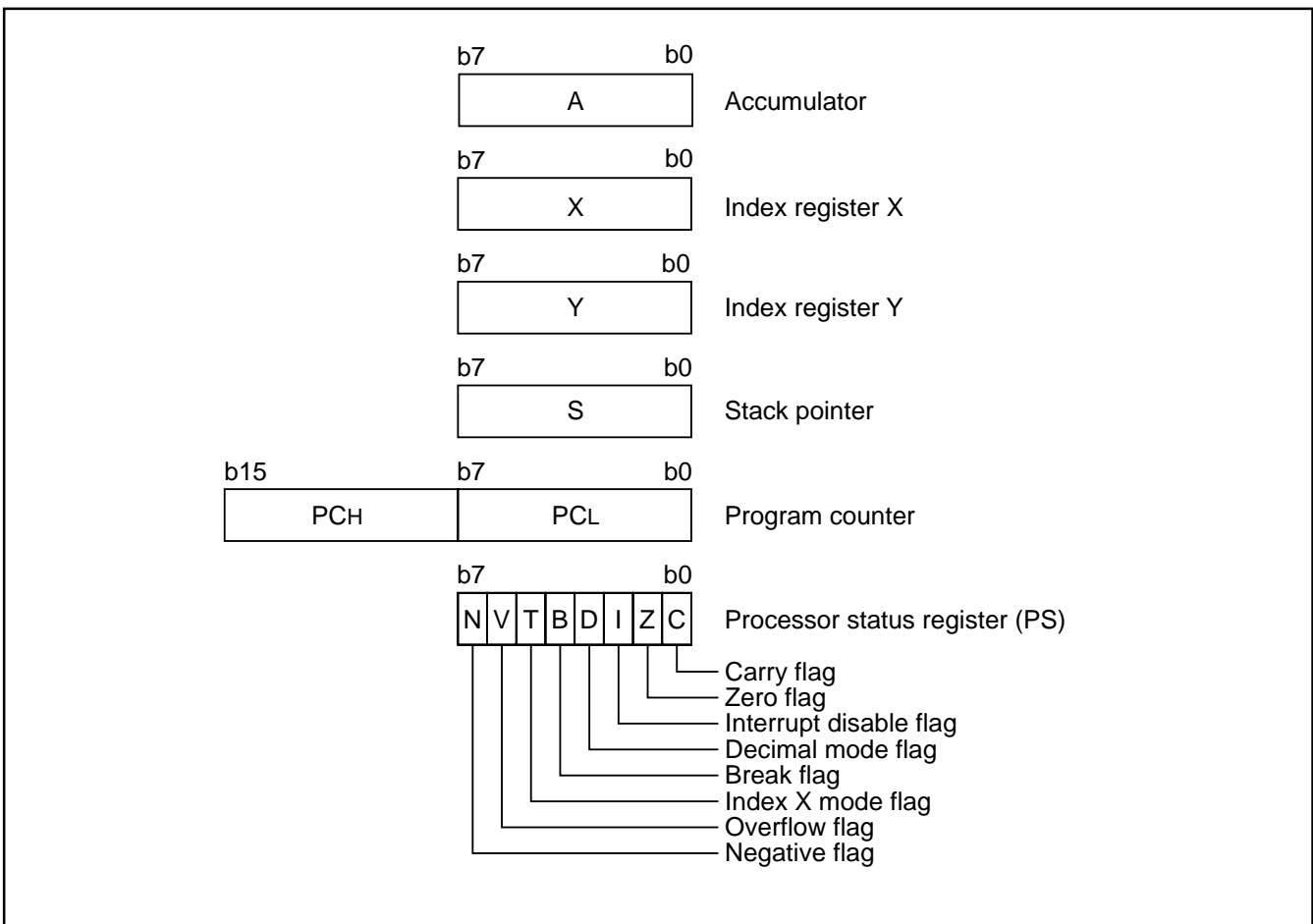

Fig. 5 740 Family CPU register structure

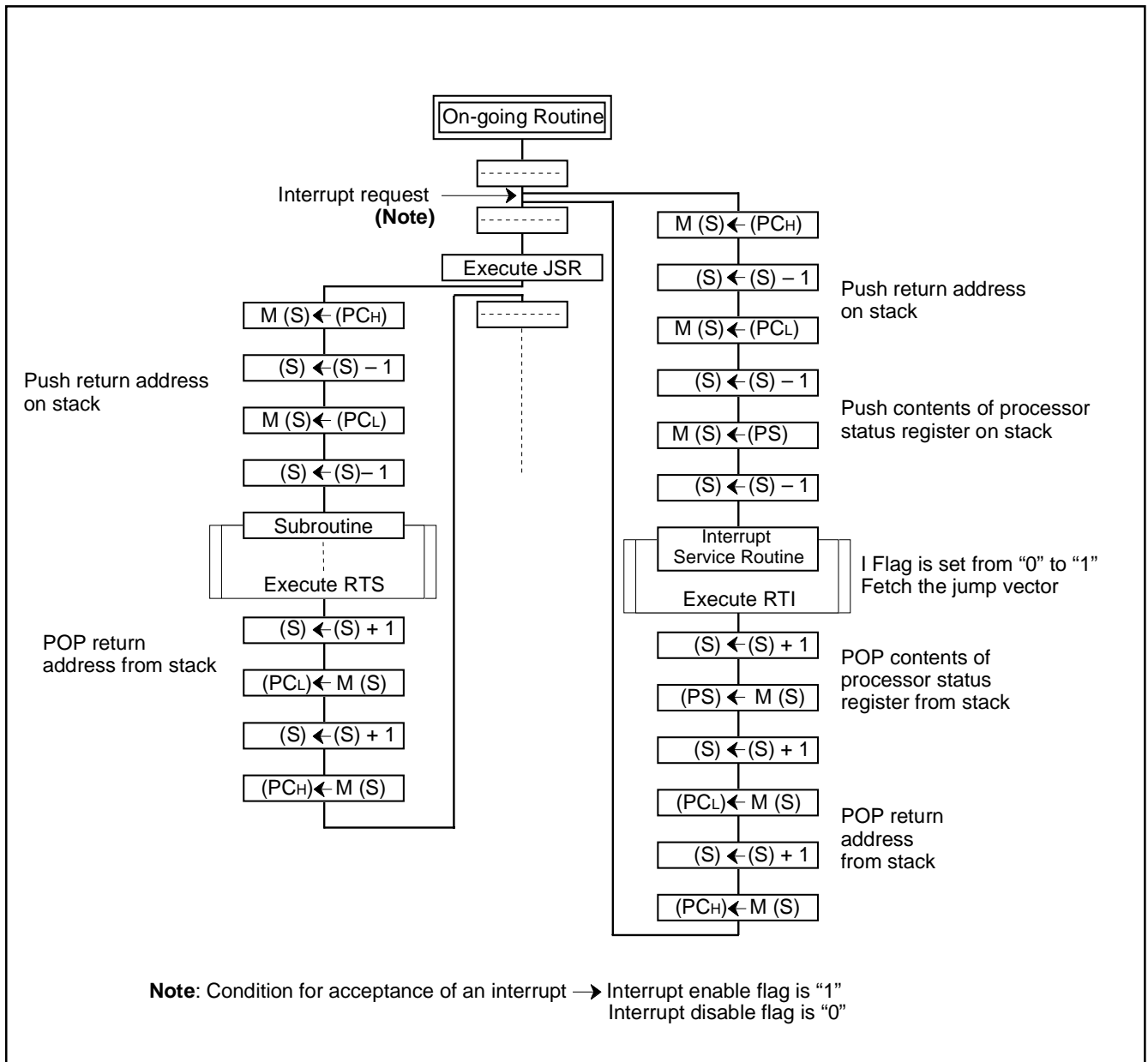

Fig. 6 Register push and pop at interrupt generation and subroutine call

Table 4 Push and pop instructions of accumulator or processor status register

	Push instruction to stack	Pop instruction from stack
Accumulator	PHA	PLA
Processor status register	PHP	PLP



**[Processor status register (PS)]**

The processor status register is an 8-bit register consisting of 5 flags which indicate the status of the processor after an arithmetic operation and 3 flags which decide MCU operation. Branch operations can be performed by testing the Carry (C) flag, Zero (Z) flag, Overflow (V) flag, or the Negative (N) flag. In decimal mode, the Z, V, N flags are not valid.

•Bit 0: Carry flag (C)

The C flag contains a carry or borrow generated by the arithmetic logic unit (ALU) immediately after an arithmetic operation. It can also be changed by a shift or rotate instruction.

•Bit 1: Zero flag (Z)

The Z flag is set if the result of an immediate arithmetic operation or a data transfer is "0", and cleared if the result is anything other than "0".

•Bit 2: Interrupt disable flag (I)

The I flag disables all interrupts except for the interrupt generated by the BRK instruction.

Interrupts are disabled when the I flag is "1".

•Bit 3: Decimal mode flag (D)

The D flag determines whether additions and subtractions are executed in binary or decimal. Binary arithmetic is executed when this flag is "0"; decimal arithmetic is executed when it is "1". Decimal correction is automatic in decimal mode. Only the ADC and SBC instructions can be used for decimal arithmetic.

•Bit 4: Break flag (B)

The B flag is used to indicate that the current interrupt was generated by the BRK instruction. The BRK flag in the processor status register is always "0". When the BRK instruction is used to generate an interrupt, the processor status register is pushed onto the stack with the break flag set to "1".

•Bit 5: Index X mode flag (T)

When the T flag is "0", arithmetic operations are performed between accumulator and memory. When the T flag is "1", direct arithmetic operations and direct data transfers are enabled between memory locations.

•Bit 6: Overflow flag (V)

The V flag is used during the addition or subtraction of one byte of signed data. It is set if the result exceeds +127 to -128. When the BIT instruction is executed, bit 6 of the memory location operated on by the BIT instruction is stored in the overflow flag.

•Bit 7: Negative flag (N)

The N flag is set if the result of an arithmetic operation or data transfer is negative. When the BIT instruction is executed, bit 7 of the memory location operated on by the BIT instruction is stored in the negative flag.

**Table 5 Set and clear instructions of each bit of processor status register**

	C flag	Z flag	I flag	D flag	B flag	T flag	V flag	N flag
Set instruction	SEC	–	SEI	SED	–	SET	–	–
Clear instruction	CLC	–	CLI	CLD	–	CLT	CLV	–

**[CPU Mode Register (CPUM)] 003B16**

The CPU mode register contains the stack page selection bit, etc.

The CPU mode register is allocated at address 003B16.

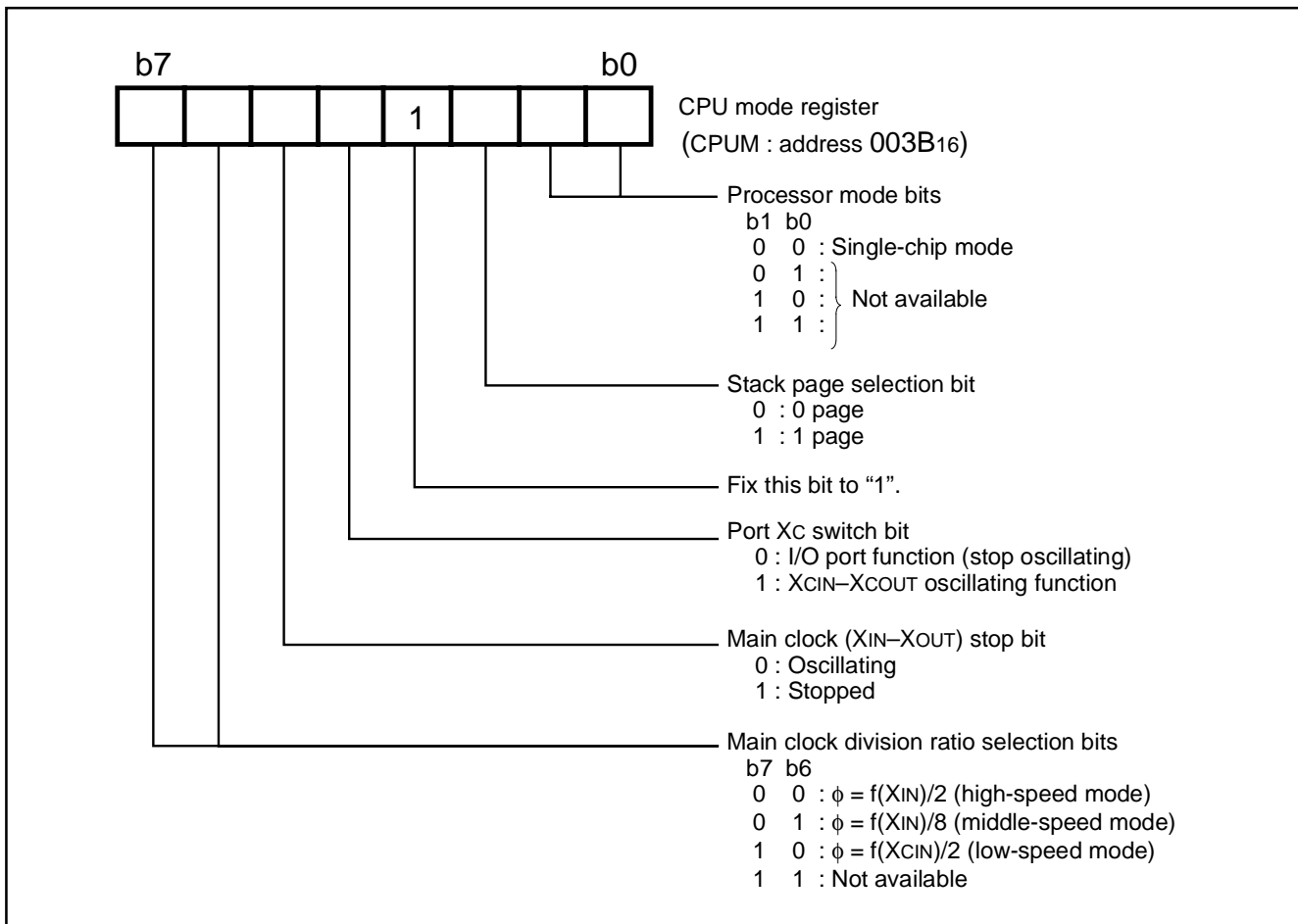

Fig. 7 Structure of CPU mode register

**MEMORY**

**Special Function Register (SFR) Area**

The Special Function Register area in the zero page contains control registers such as I/O ports and timers.

**RAM**

RAM is used for data storage and for stack area of subroutine calls and interrupts.

**ROM**

The first 128 bytes and the last 2 bytes of ROM are reserved for device testing and the rest is user area for storing programs.

**Interrupt Vector Area**

The interrupt vector area contains reset and interrupt vectors.

**Zero Page**

Access to this area with only 2 bytes is possible in the zero page addressing mode.

**Special Page**

Access to this area with only 2 bytes is possible in the special page addressing mode.

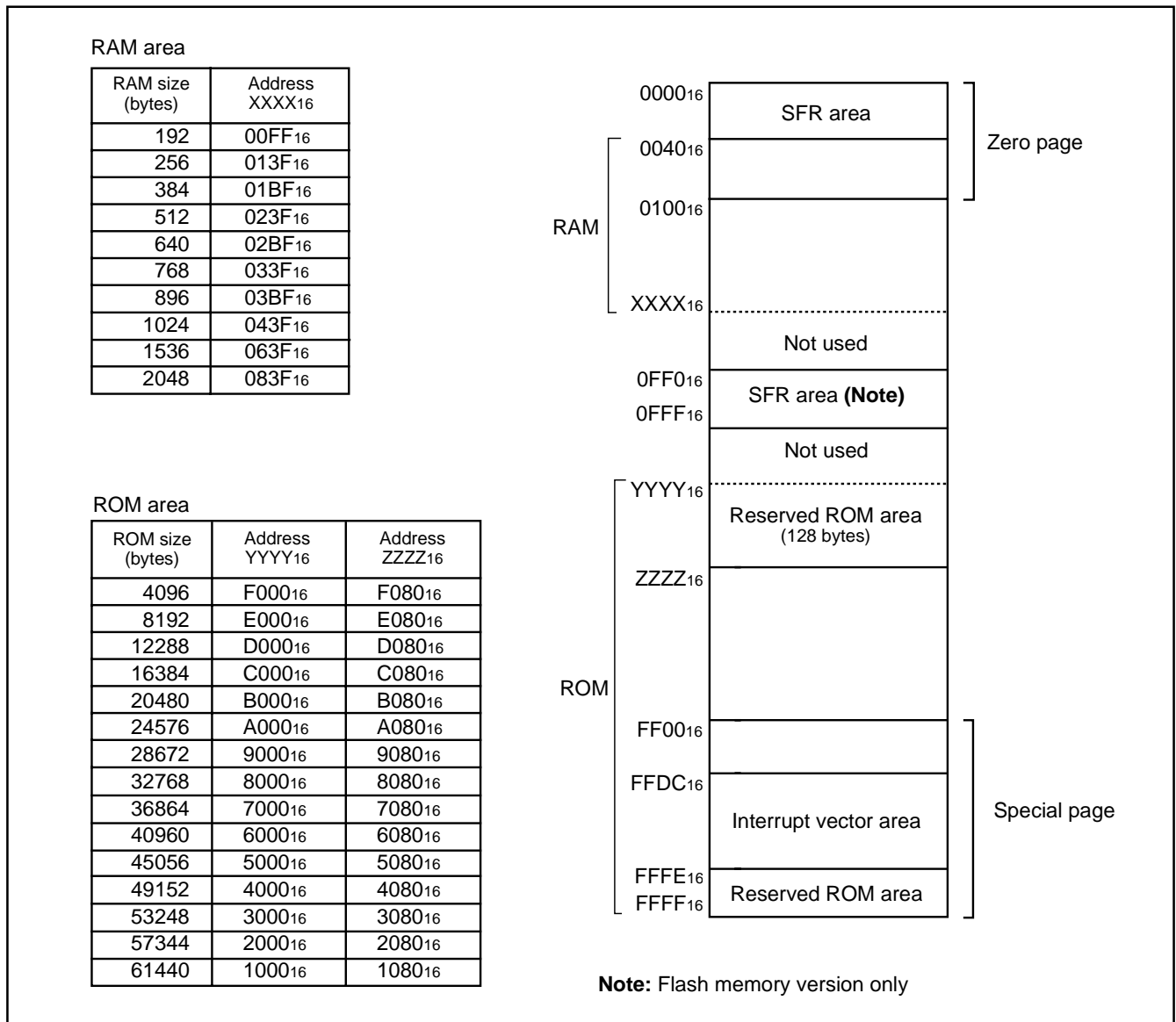

Fig. 8 Memory map diagram

0000 <sub>16</sub>	Port P0 (P0)	0020 <sub>16</sub>	Prescaler 12 (PRE12)
0001 <sub>16</sub>	Port P0 direction register (P0D)	0021 <sub>16</sub>	Timer 1 (T1)
0002 <sub>16</sub>	Port P1 (P1)	0022 <sub>16</sub>	Timer 2 (T2)
0003 <sub>16</sub>	Port P1 direction register (P1D)	0023 <sub>16</sub>	Timer XY mode register (TM)
0004 <sub>16</sub>	Port P2 (P2)	0024 <sub>16</sub>	Prescaler X (PREX)
0005 <sub>16</sub>	Port P2 direction register (P2D)	0025 <sub>16</sub>	Timer X (TX)
0006 <sub>16</sub>	Port P3 (P3)	0026 <sub>16</sub>	Prescaler Y (PREY)
0007 <sub>16</sub>	Port P3 direction register (P3D)	0027 <sub>16</sub>	Timer Y (TY)
0008 <sub>16</sub>	Port P4 (P4)	0028 <sub>16</sub>	Timer count source selection register (TCSS)
0009 <sub>16</sub>	Port P4 direction register (P4D)	0029 <sub>16</sub>	
000A <sub>16</sub>		002A <sub>16</sub>	
000B <sub>16</sub>		002B <sub>16</sub>	Reserved *
000C <sub>16</sub>		002C <sub>16</sub>	Reserved *
000D <sub>16</sub>		002D <sub>16</sub>	Reserved *
000E <sub>16</sub>		002E <sub>16</sub>	Reserved *
000F <sub>16</sub>		002F <sub>16</sub>	Reserved *
0010 <sub>16</sub>		0030 <sub>16</sub>	Reserved *
0011 <sub>16</sub>		0031 <sub>16</sub>	Reserved *
0012 <sub>16</sub>	Port P0, P1, P2 pull-up control register (PULL012)	0032 <sub>16</sub>	
0013 <sub>16</sub>	Port P3 pull-up control register (PULL3)	0033 <sub>16</sub>	
0014 <sub>16</sub>	Port P4 pull-up control register (PULL4)	0034 <sub>16</sub>	AD control register (ADCON)
0015 <sub>16</sub>	Serial I/O2 control register 1 (SIO2CON1)	0035 <sub>16</sub>	AD conversion low-order register (ADL)
0016 <sub>16</sub>	Serial I/O2 control register 2 (SIO2CON2)	0036 <sub>16</sub>	AD conversion high-order register (ADH)
0017 <sub>16</sub>	Serial I/O2 register (SIO2)	0037 <sub>16</sub>	AD input selection register (ADSEL)
0018 <sub>16</sub>	Transmit/Receive buffer register (TB/RB)	0038 <sub>16</sub>	MISRG
0019 <sub>16</sub>	Serial I/O1 status register (SIOSTS)	0039 <sub>16</sub>	Watchdog timer control register (WDTCON)
001A <sub>16</sub>	Serial I/O1 control register (SIOCON)	003A <sub>16</sub>	Interrupt edge selection register (INTEDGE)
001B <sub>16</sub>	UART control register (UARTCON)	003B <sub>16</sub>	CPU mode register (CPUM)
001C <sub>16</sub>	Baud rate generator (BRG)	003C <sub>16</sub>	Interrupt request register 1 (IREQ1)
001D <sub>16</sub>	PWM control register (PWMCON)	003D <sub>16</sub>	Interrupt request register 2 (IREQ2)
001E <sub>16</sub>	PWM prescaler (PREPWM)	003E <sub>16</sub>	Interrupt control register 1 (ICON1)
001F <sub>16</sub>	PWM register (PWM)	003F <sub>16</sub>	Interrupt control register 2 (ICON2)
		00FE <sub>16</sub>	Flash memory control register (FMCR)

\* Reserved : Do not write any data to this addresses, because these areas are reserved.

Fig. 9 Memory map of special function register (SFR)

## I/O PORTS

The I/O ports have direction registers which determine the input/output direction of each individual pin. Each bit in a direction register corresponds to one pin, and each pin can be set to be input port or output port.

When "0" is written to the bit corresponding to a pin, that pin becomes an input pin. When "1" is written to that bit, that pin becomes an output pin.

If data is read from a pin which is set to output, the value of the port output latch is read, not the value of the pin itself. Pins set to input are floating. If a pin set to input is written to, only the port output latch is written to and the pin remains floating.

By setting the port P0, P1, P2 pull-up control register (address 001216), the port P3 pull-up control register (address 001316), or the port P4 pull-up control register (address 001416), ports can control pull-up with a program. However, the contents of these registers do not affect ports programmed as the output ports.

**Table 6 I/O port function**

Pin	Name	Input/Output	I/O Structure	Non-Port Function	Related SFRs	Ref.No.	
P00/SIN2 P01/SOUT2 P02/SCLK2 P03/SRDY2	Port P0	Input/output, individual bits	CMOS compatible input level CMOS 3-state output	Serial I/O2 function I/O	Serial I/O2 control register	(1) (2) (3) (4)	
P04/AN5–P07/AN8				A/D converter input	AD control register AD input selection register	(13)	
P10–P17	Port P1						(5)
P20/XCOUT P21/XCIN	Port P2				Sub-clock generating circuit	CPU mode register	(6) (7)
P22 P23				CMOS compatible input level N-channel open-drain output			(8)
P24/RxD P25/TxD P26/SCLK1				Serial I/O1 function I/O	Serial I/O1 control register	(9) (10) (11)	
P27/CNTR0/SRDY1				Serial I/O1 function I/O Timer X function I/O	Serial I/O1 control register Timer XY mode register	(12)	
P30/AN0– P34/AN4			Port P3 <b>(Note)</b>	A/D converter input	AD control register AD input selection register	(13)	
P40/CNTR1	Port P4 <b>(Note)</b>		CMOS compatible input level CMOS 3-state output	Timer Y function I/O	Timer XY mode register	(14)	
P41/INT0 P42/INT1			External interrupt input	Interrupt edge selection register	(15)		
P43/INT2/SCMP2			External interrupt input SCMP2 output	Interrupt edge selection register Serial I/O2 control register	(16)		
P44/INT3/PWM			External interrupt input PWM output	Interrupt edge selection register PWM control register	(17)		

**Note:** When bits 5 to 7 of Ports P3 and P4 are read out, the contents are undefined.

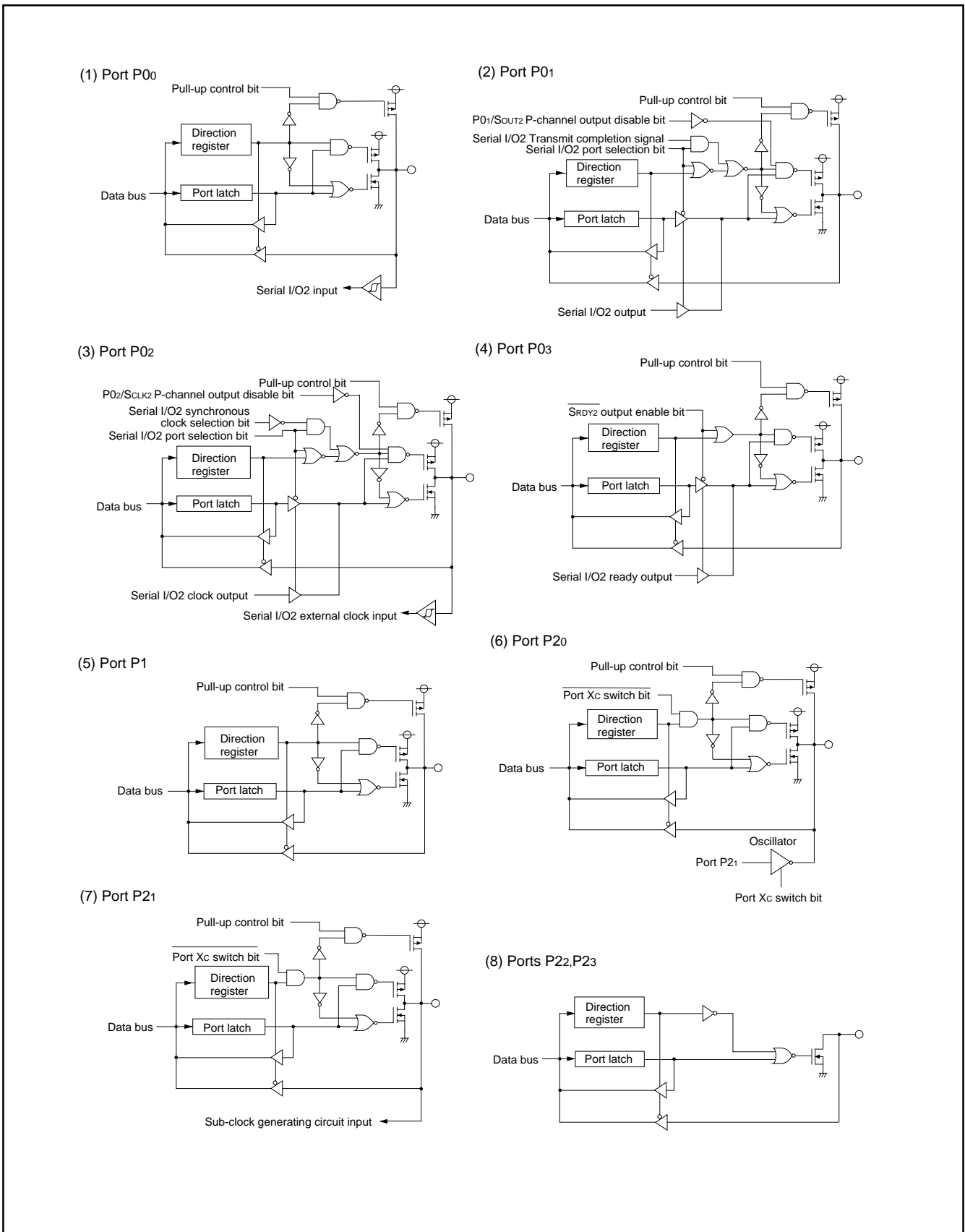

Fig. 10 Port block diagram (1)

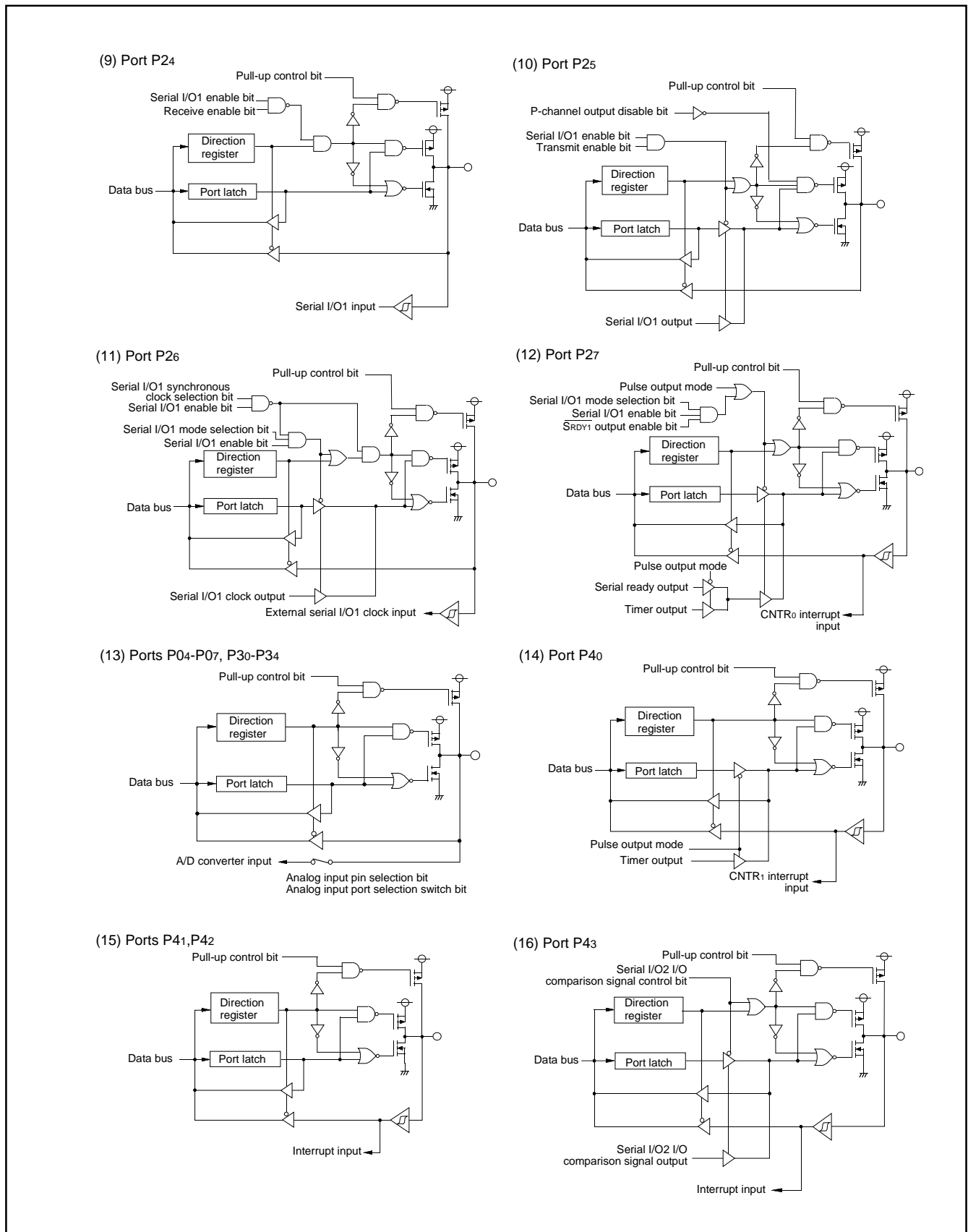

Fig. 11 Port block diagram (2)

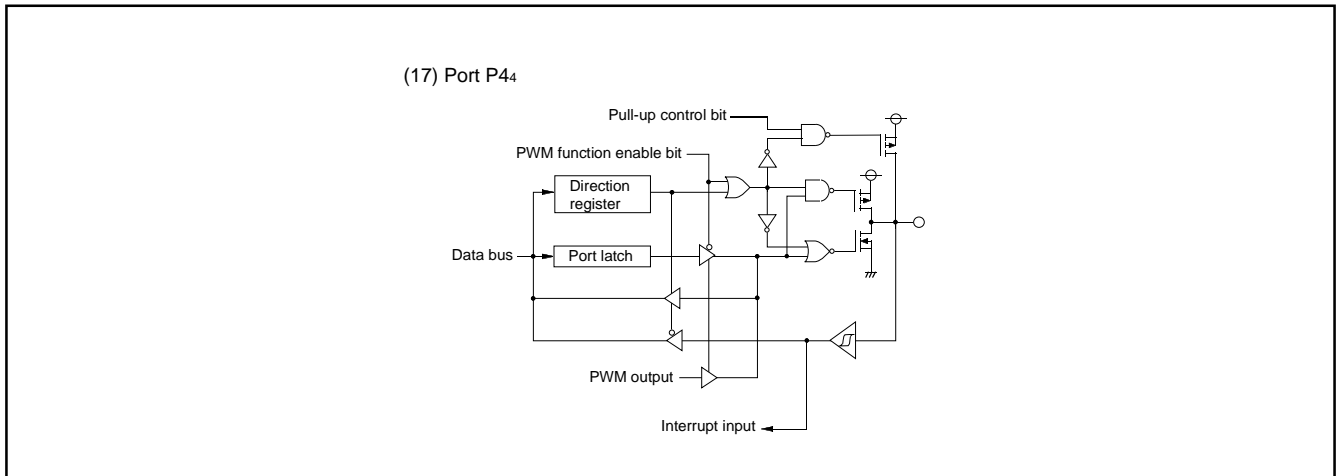

Fig. 12 Port block diagram (3)



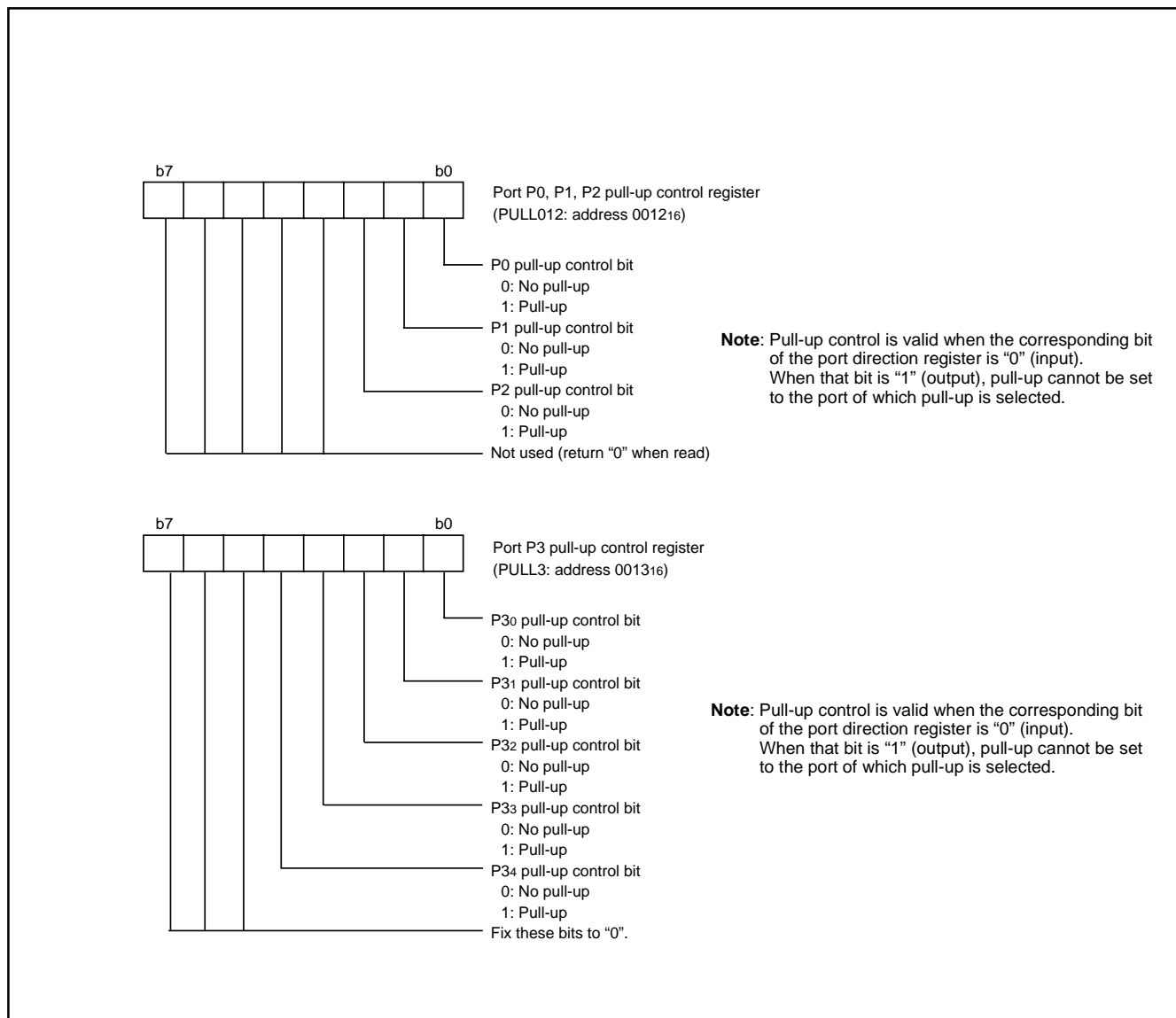

Fig. 13 Structure of port registers (1)

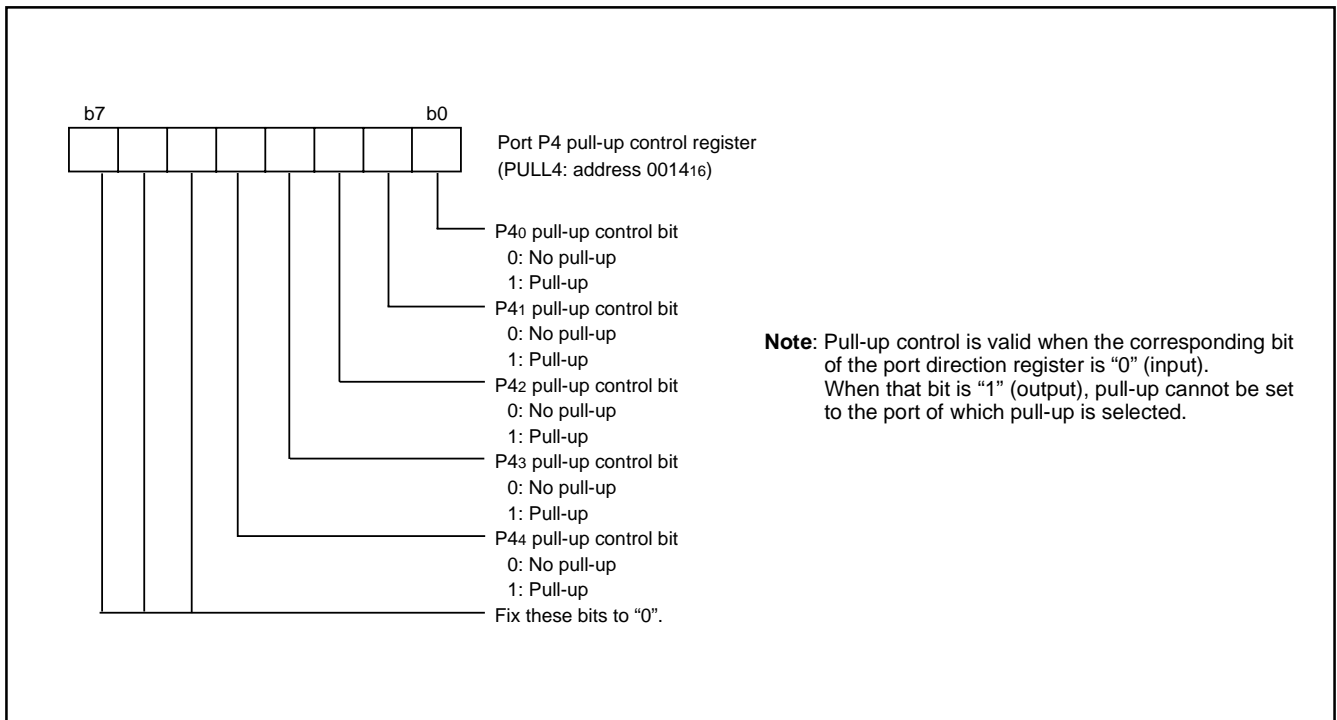

Fig. 14 Structure of port registers (2)

## INTERRUPTS

Interrupts occur by 15 sources among 15 sources: six external, eight internal, and one software.

### Interrupt Control

Each interrupt is controlled by an interrupt request bit, an interrupt enable bit, and the interrupt disable flag except for the software interrupt set by the BRK instruction. An interrupt occurs if the corresponding interrupt request and enable bits are "1" and the interrupt disable flag is "0".

Interrupt enable bits can be set or cleared by software.

Interrupt request bits can be cleared by software, but cannot be set by software.

The BRK instruction cannot be disabled with any flag or bit. The I (interrupt disable) flag disables all interrupts except the BRK instruction interrupt.

When several interrupts occur at the same time, the interrupts are received according to priority.

### Interrupt Operation

By acceptance of an interrupt, the following operations are automatically performed:

1. The contents of the program counter and the processor status register are automatically pushed onto the stack.
2. The interrupt disable flag is set and the corresponding interrupt request bit is cleared.
3. The interrupt jump destination address is read from the vector table into the program counter.

## ■Notes

When setting the followings, the interrupt request bit may be set to "1".

- When setting external interrupt active edge

Related register: Interrupt edge selection register (address 003A16)  
Timer XY mode register (address 002316)

- When switching interrupt sources of an interrupt vector address where two or more interrupt sources are allocated

Related register: Interrupt edge selection register (address 003A16)  
When not requiring for the interrupt occurrence synchronized with these setting, take the following sequence.

- (1) Set the corresponding interrupt enable bit to "0" (disabled).
- (2) Set the interrupt edge select bit or the interrupt source select bit to "1".
- (3) Set the corresponding interrupt request bit to "0" after 1 or more instructions have been executed.
- (4) Set the corresponding interrupt enable bit to "1" (enabled).

**Table 7 Interrupt vector addresses and priority**

Interrupt Source	Priority	Vector Addresses ( <b>Note 1</b> )		Interrupt Request Generating Conditions	Remarks
		High	Low		
Reset (Note 2)	1	FFFD <sub>16</sub>	FFFC <sub>16</sub>	At reset	Non-maskable
INT <sub>0</sub>	2	FFFB <sub>16</sub>	FFFA <sub>16</sub>	At detection of either rising or falling edge of INT <sub>0</sub> input	External interrupt (active edge selectable)
Reserved	3	FFF9 <sub>16</sub>	FFF8 <sub>16</sub>	Reserved	
INT <sub>1</sub>	4	FFF7 <sub>16</sub>	FFF6 <sub>16</sub>	At detection of either rising or falling edge of INT <sub>1</sub> input	External interrupt (active edge selectable)
INT <sub>2</sub>	5	FFF5 <sub>16</sub>	FFF4 <sub>16</sub>	At detection of either rising or falling edge of INT <sub>2</sub> input	External interrupt (active edge selectable)
INT <sub>3</sub> / Serial I/O <sub>2</sub>	6	FFF3 <sub>16</sub>	FFF2 <sub>16</sub>	At detection of either rising or falling edge of INT <sub>3</sub> input/ At completion of serial I/O <sub>2</sub> data reception/transmission	External interrupt (active edge selectable) Switch by Serial I/O <sub>2</sub> /INT <sub>3</sub> interrupt source bit
Reserved	7	FFF1 <sub>16</sub>	FFF0 <sub>16</sub>	Reserved	
Timer X	8	FFEF <sub>16</sub>	FFEE <sub>16</sub>	At timer X underflow	
Timer Y	9	FFED <sub>16</sub>	FFEC <sub>16</sub>	At timer Y underflow	
Timer 1	10	FFEB <sub>16</sub>	FFEA <sub>16</sub>	At timer 1 underflow	STP release timer underflow
Timer 2	11	FFE9 <sub>16</sub>	FFE8 <sub>16</sub>	At timer 2 underflow	
Serial I/O <sub>1</sub> reception	12	FFE7 <sub>16</sub>	FFE6 <sub>16</sub>	At completion of serial I/O <sub>1</sub> data reception	Valid when serial I/O <sub>1</sub> is selected
Serial I/O <sub>1</sub> transmission	13	FFE5 <sub>16</sub>	FFE4 <sub>16</sub>	At completion of serial I/O <sub>1</sub> transfer shift or when transmission buffer is empty	Valid when serial I/O <sub>1</sub> is selected
CNTR <sub>0</sub>	14	FFE3 <sub>16</sub>	FFE2 <sub>16</sub>	At detection of either rising or falling edge of CNTR <sub>0</sub> input	External interrupt (active edge selectable)
CNTR <sub>1</sub>	15	FFE1 <sub>16</sub>	FFE0 <sub>16</sub>	At detection of either rising or falling edge of CNTR <sub>1</sub> input	External interrupt (active edge selectable)
A/D converter	16	FFDF <sub>16</sub>	FFDE <sub>16</sub>	At completion of A/D conversion	
BRK instruction	17	FFDD <sub>16</sub>	FFDC <sub>16</sub>	At BRK instruction execution	Non-maskable software interrupt

**Notes 1:** Vector addresses contain interrupt jump destination addresses.

**2:** Reset function in the same way as an interrupt with the highest priority.

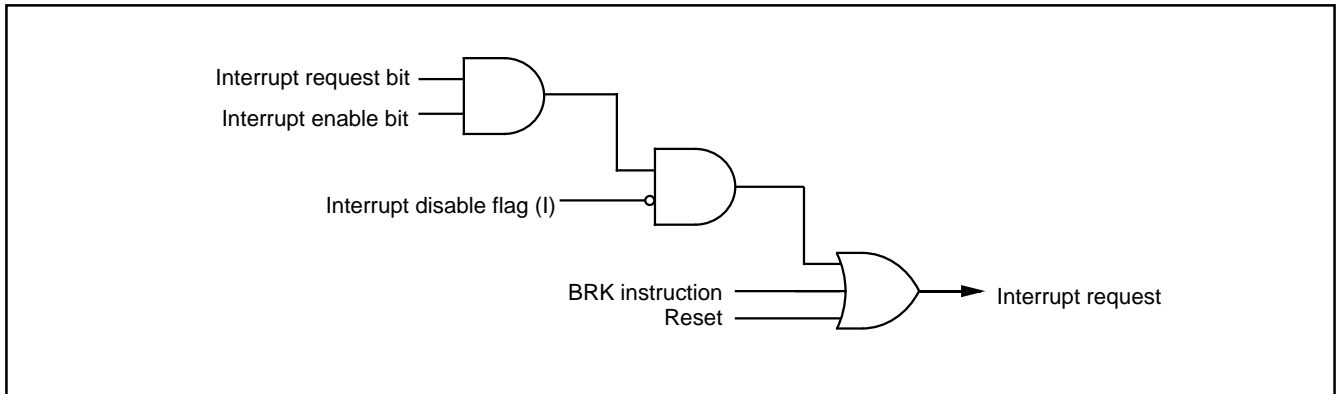

Fig. 15 Interrupt control

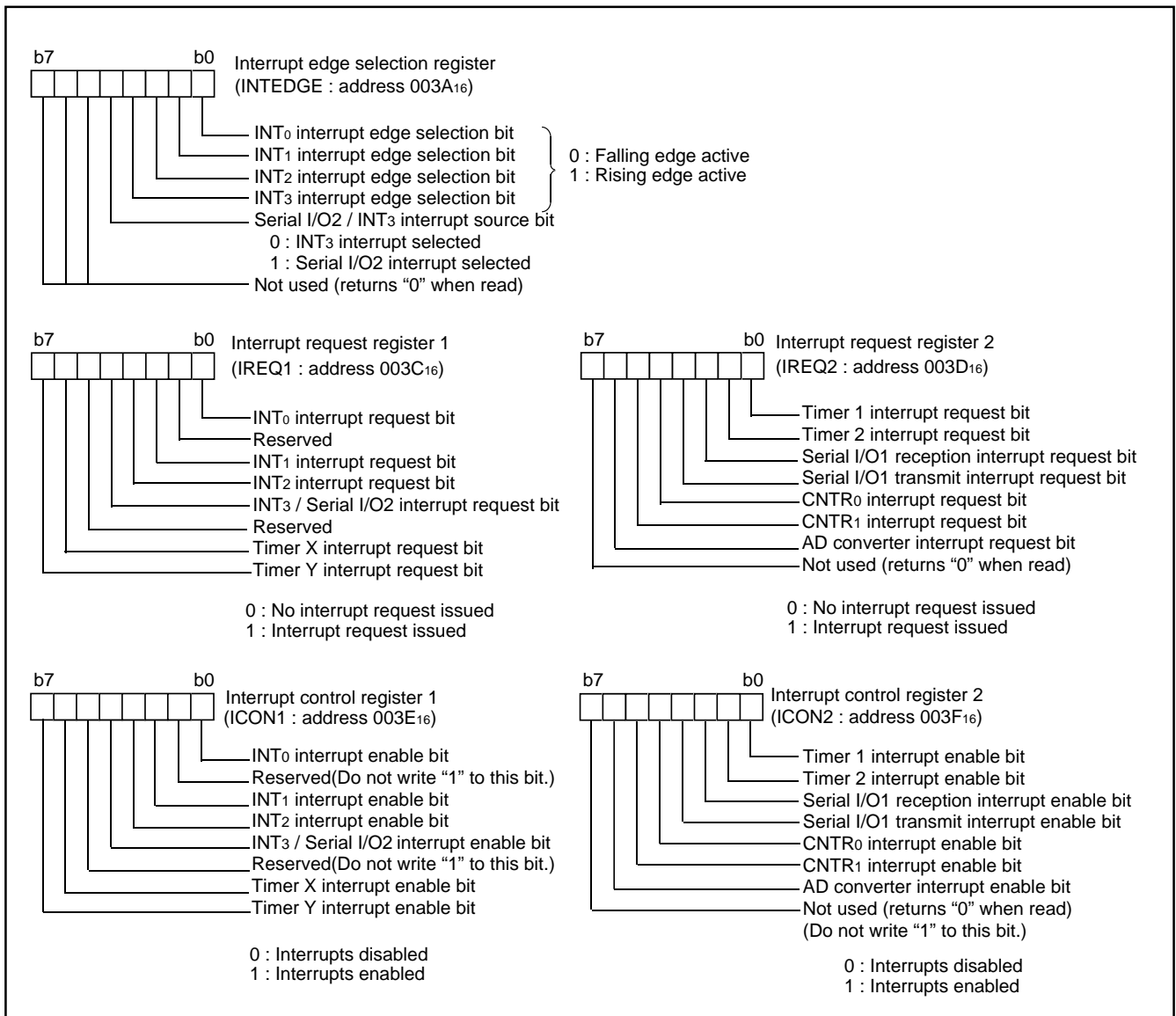

Fig. 16 Structure of interrupt-related registers

## TIMERS

The 3850 group (spec. A) has four timers: timer X, timer Y, timer 1, and timer 2.

The division ratio of each timer or prescaler is given by  $1/(n + 1)$ , where n is the value in the corresponding timer or prescaler latch. All timers are count down. When the timer reaches "0016", an underflow occurs at the next count pulse and the corresponding timer latch is reloaded into the timer and the count is continued. When a timer underflows, the interrupt request bit corresponding to that timer is set to "1".

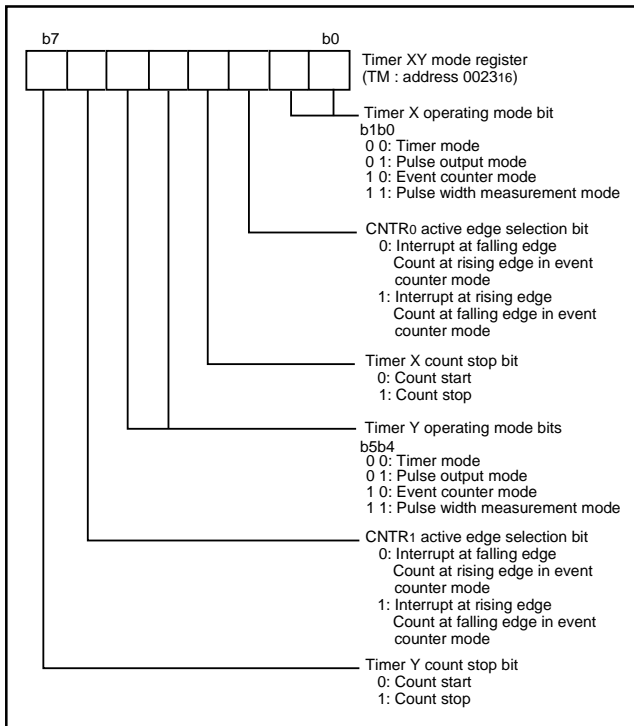

Fig. 17 Structure of timer XY mode register

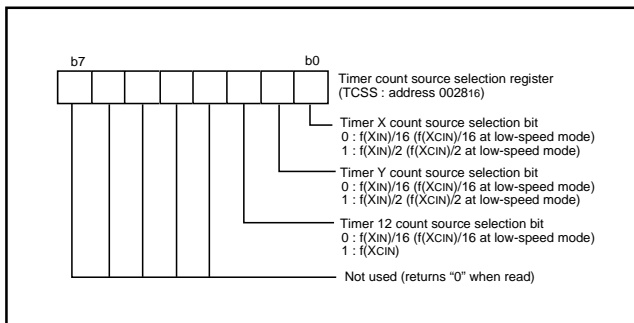

Fig. 18 Structure of timer count source selection register

## Timer 1 and Timer 2

The count source of prescaler 12 is the oscillation frequency which is selected by timer 12 count source selection bit. The output of prescaler 12 is counted by timer 1 and timer 2, and a timer underflow sets the interrupt request bit.

## Timer X and Timer Y

Timer X and Timer Y can each select in one of four operating modes by setting the timer XY mode register.

### (1) Timer Mode

The timer counts the count source selected by Timer count source selection bit.

### (2) Pulse Output Mode

The timer counts the count source selected by Timer count source selection bit. Whenever the contents of the timer reach "0016", the signal output from the CNTR0 (or CNTR1) pin is inverted. If the CNTR0 (or CNTR1) active edge selection bit is "0", output begins at "H".

If it is "1", output starts at "L". When using a timer in this mode, set the corresponding port P27 ( or port P40) direction register to output mode.

### (3) Event Counter Mode

Operation in event counter mode is the same as in timer mode, except that the timer counts signals input through the CNTR0 or CNTR1 pin.

When the CNTR0 (or CNTR1) active edge selection bit is "0", the rising edge of the CNTR0 (or CNTR1) pin is counted.

When the CNTR0 (or CNTR1) active edge selection bit is "1", the falling edge of the CNTR0 (or CNTR1) pin is counted.

### (4) Pulse Width Measurement Mode

If the CNTR0 (or CNTR1) active edge selection bit is "0", the timer counts the selected signals by the count source selection bit while the CNTR0 (or CNTR1) pin is at "H". If the CNTR0 (or CNTR1) active edge selection bit is "1", the timer counts it while the CNTR0 (or CNTR1) pin is at "L".

The count can be stopped by setting "1" to the timer X (or timer Y) count stop bit in any mode. The corresponding interrupt request bit is set each time a timer underflows.

### Note

When switching the count source by the timer 12, X and Y count source bits, the value of timer count is altered in unconsiderable amount owing to generating of a thin pulses in the count input signals.

Therefore, select the timer count source before set the value to the prescaler and the timer.

When timer X/timer Y underflow while executing the instruction which sets "1" to the timer X/timer Y count stop bits, the timer X/timer Y interrupt request bits are set to "1". Timer X/Timer Y interrupts are received if these interrupts are enabled at this time. The timing which interrupt is accepted has a case after the instruction which sets "1" to the count stop bit, and a case after the next instruction according to the timing of the timer underflow. When this interrupt is unnecessary, set "0" (disabled) to the interrupt enable bit and then set "1" to the count stop bit.

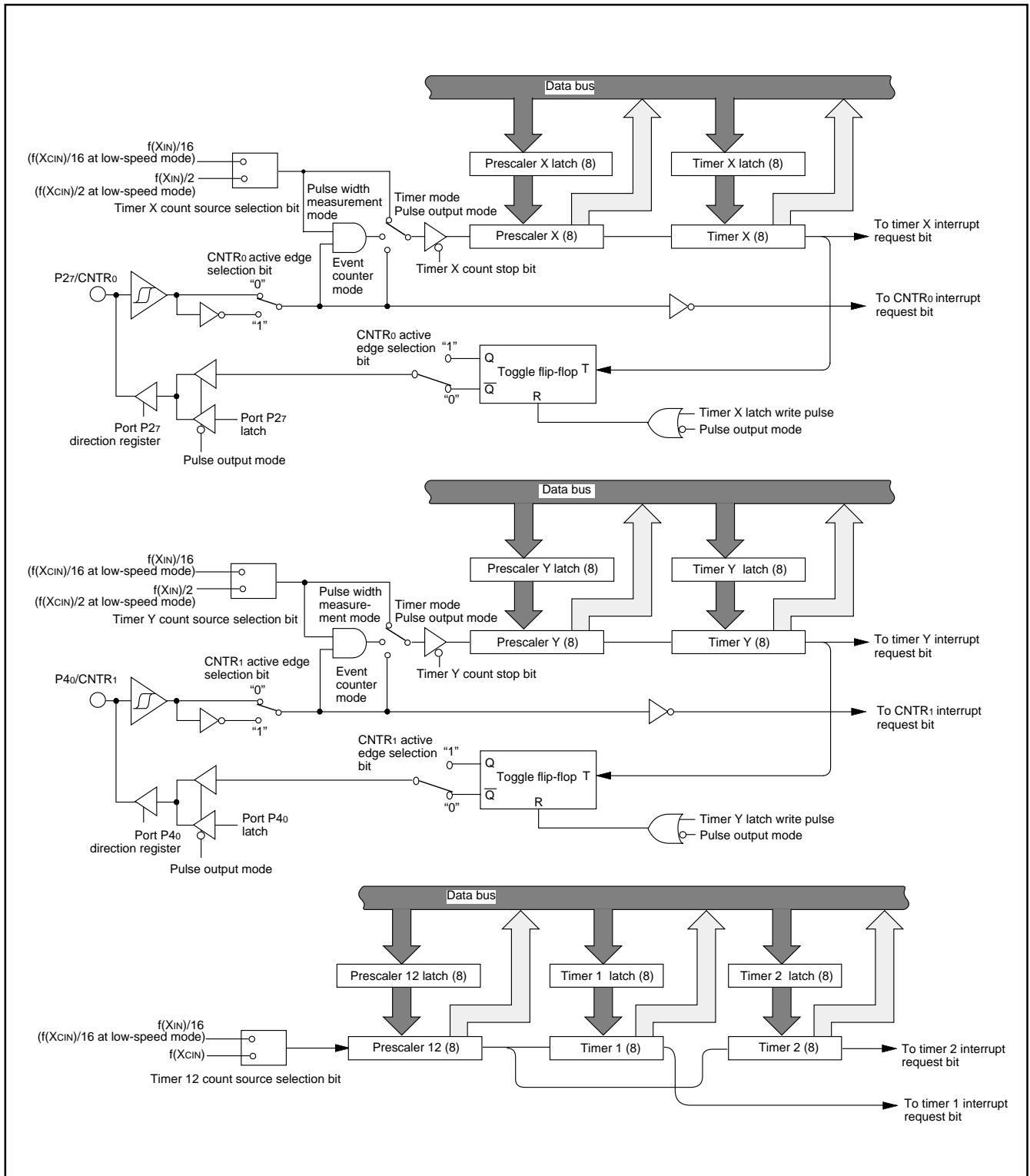

Fig. 19 Block diagram of timer X, timer Y, timer 1, and timer 2

**SERIAL INTERFACE**  
**●SERIAL I/O1**

Serial I/O1 can be used as either clock synchronous or asynchronous (UART) serial I/O. A dedicated timer is also provided for baud rate generation.

**(1) Clock Synchronous Serial I/O Mode**

Clock synchronous serial I/O mode can be selected by setting the serial I/O1 mode selection bit of the serial I/O1 control register (bit 6 of address 001A16) to "1".

For clock synchronous serial I/O, the transmitter and the receiver must use the same clock. If an internal clock is used, transfer is started by a write signal to the TB/RB.

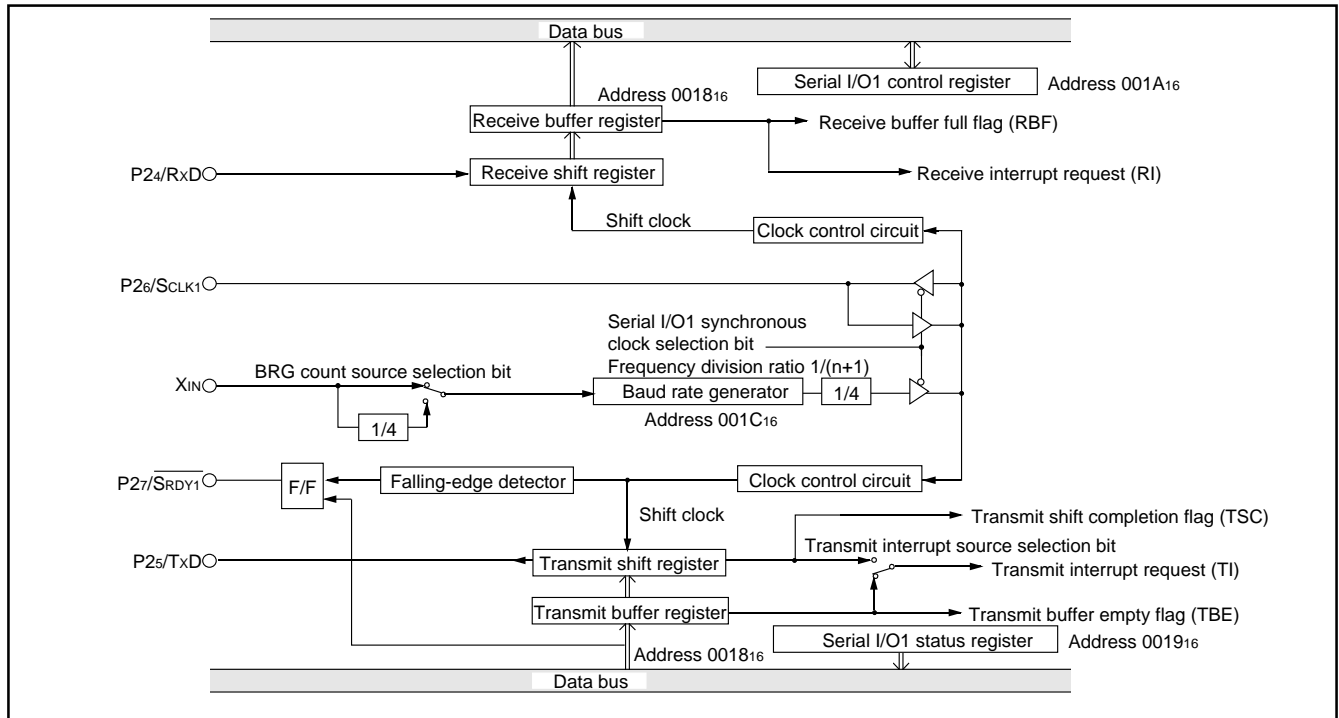

Fig. 20 Block diagram of clock synchronous serial I/O1

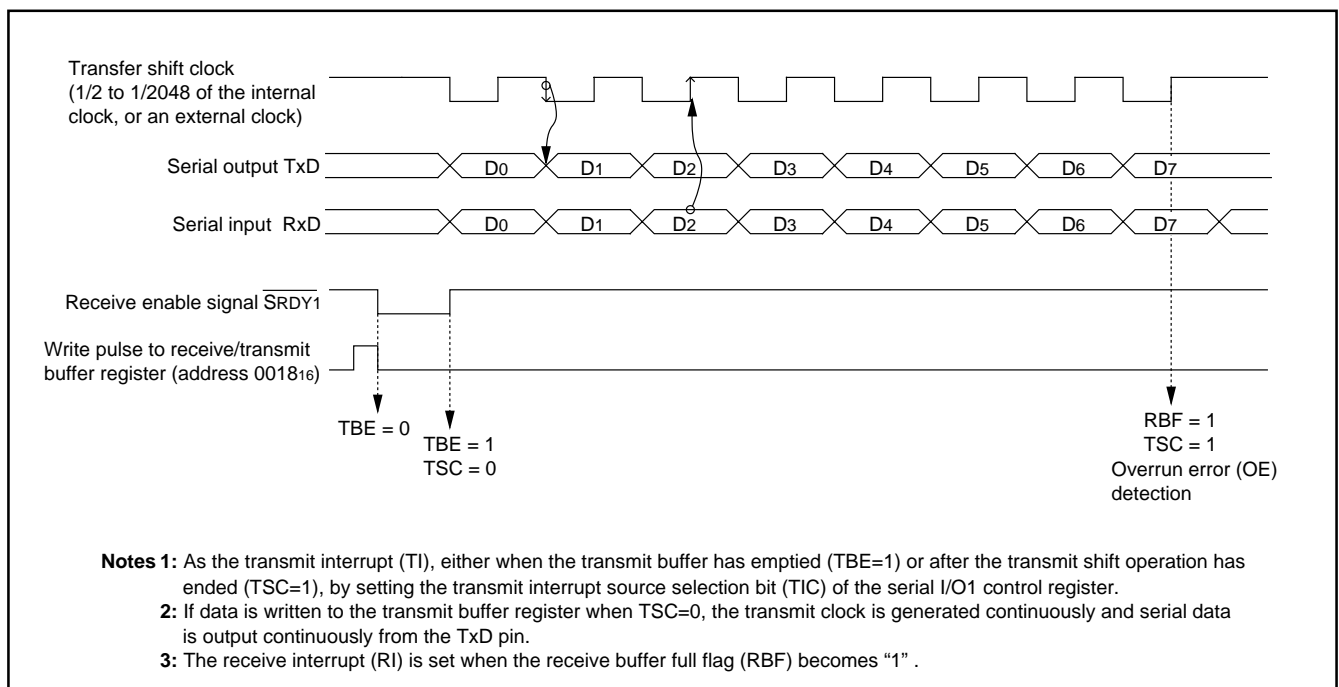

Fig. 21 Operation of clock synchronous serial I/O1 function



## (2) Asynchronous Serial I/O (UART) Mode

Clock asynchronous serial I/O mode (UART) can be selected by clearing the serial I/O1 mode selection bit (b6) of the serial I/O1 control register to "0".

Eight serial data transfer formats can be selected, and the transfer formats used by a transmitter and receiver must be identical.

The transmit and receive shift registers each have a buffer, but the

two buffers have the same address in memory. Since the shift register cannot be written to or read from directly, transmit data is written to the transmit buffer register, and receive data is read from the receive buffer register.

The transmit buffer register can also hold the next data to be transmitted, and the receive buffer register can hold a character while the next character is being received.

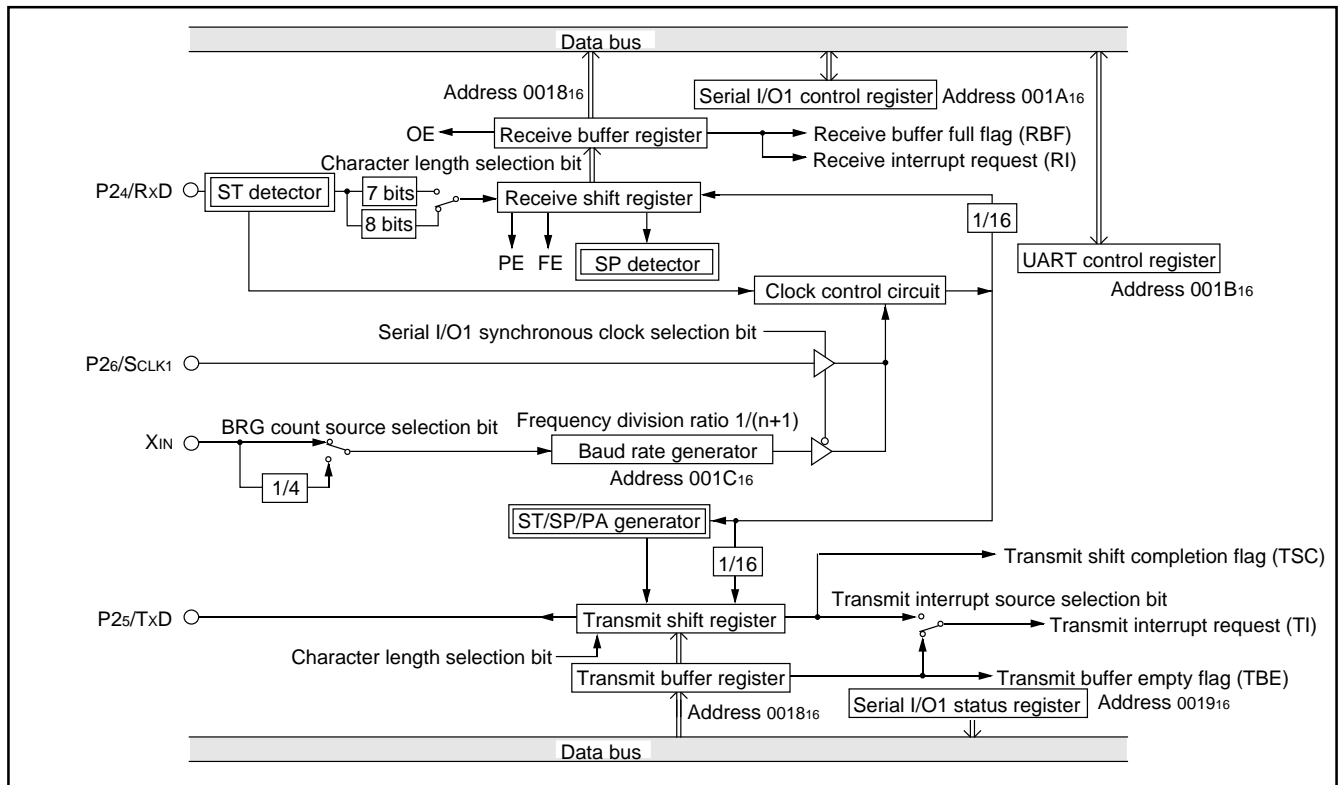

Fig. 22 Block diagram of UART serial I/O1

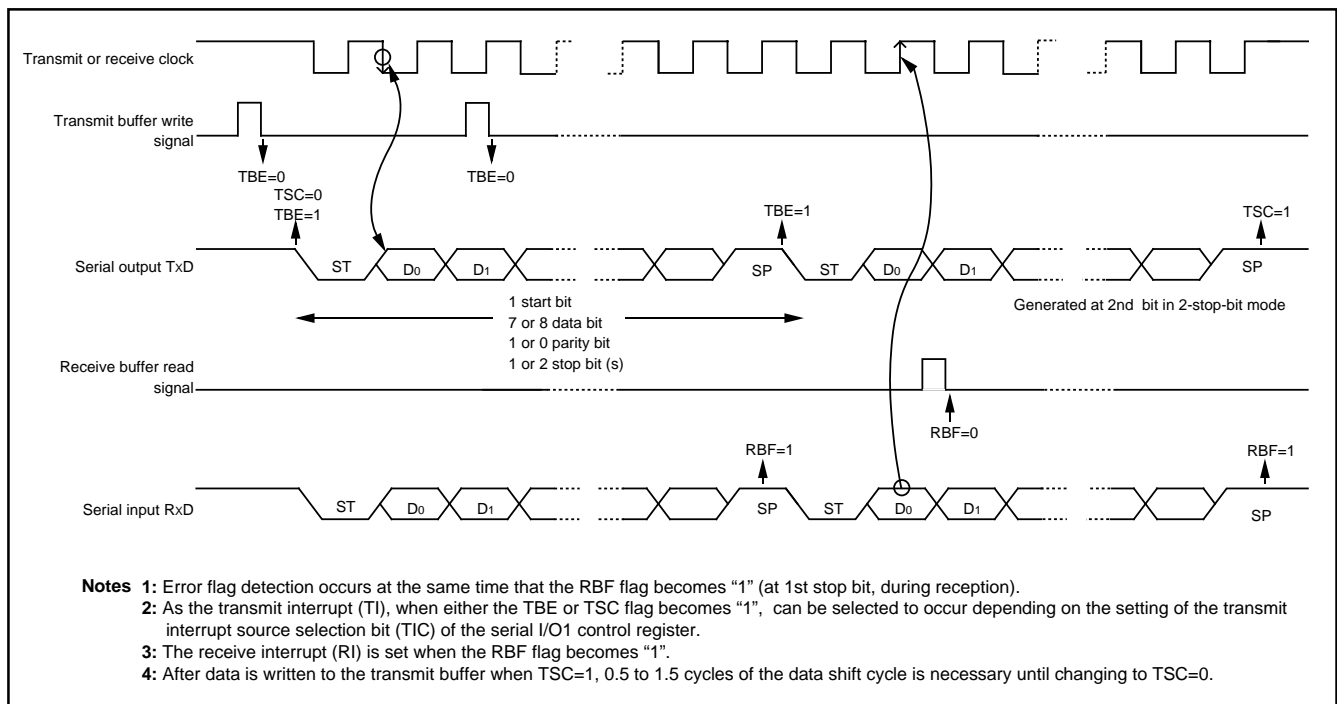

Fig. 23 Operation of UART serial I/O1 function

### [Transmit Buffer Register/Receive Buffer Register (TB/RB)] 001816

The transmit buffer register and the receive buffer register are located at the same address. The transmit buffer is write-only and the receive buffer is read-only. If a character bit length is 7 bits, the MSB of data stored in the receive buffer is "0".

### [Serial I/O1 Status Register (SIOSTS)] 001916

The read-only serial I/O1 status register consists of seven flags (bits 0 to 6) which indicate the operating status of the serial I/O1 function and various errors.

Three of the flags (bits 4 to 6) are valid only in UART mode.

The receive buffer full flag (bit 1) is cleared to "0" when the receive buffer register is read.

If there is an error, it is detected at the same time that data is transferred from the receive shift register to the receive buffer register, and the receive buffer full flag is set. A write to the serial I/O1 status register clears all the error flags OE, PE, FE, and SE (bit 3 to bit 6, respectively). Writing "0" to the serial I/O1 enable bit SIOE (bit 7 of the serial I/O1 control register) also clears all the status flags, including the error flags.

Bits 0 to 6 of the serial I/O1 status register are initialized to "0" at reset, but if the transmit enable bit (bit 4) of the serial I/O1 control register has been set to "1", the transmit shift completion flag (bit 2) and the transmit buffer empty flag (bit 0) become "1".

### [Serial I/O1 Control Register (SIOCON)] 001A16

The serial I/O1 control register consists of eight control bits for the serial I/O1 function.

### [UART Control Register (UARTCON)] 001B16

The UART control register consists of four control bits (bits 0 to 3) which are valid when asynchronous serial I/O is selected and set the data format of an data transfer and one bit (bit 4) which is always valid and sets the output structure of the P25/TxD pin.

### [Baud Rate Generator (BRG)] 001C16

The baud rate generator determines the baud rate for serial transfer.

The baud rate generator divides the frequency of the count source by  $1/(n + 1)$ , where n is the value written to the baud rate generator.

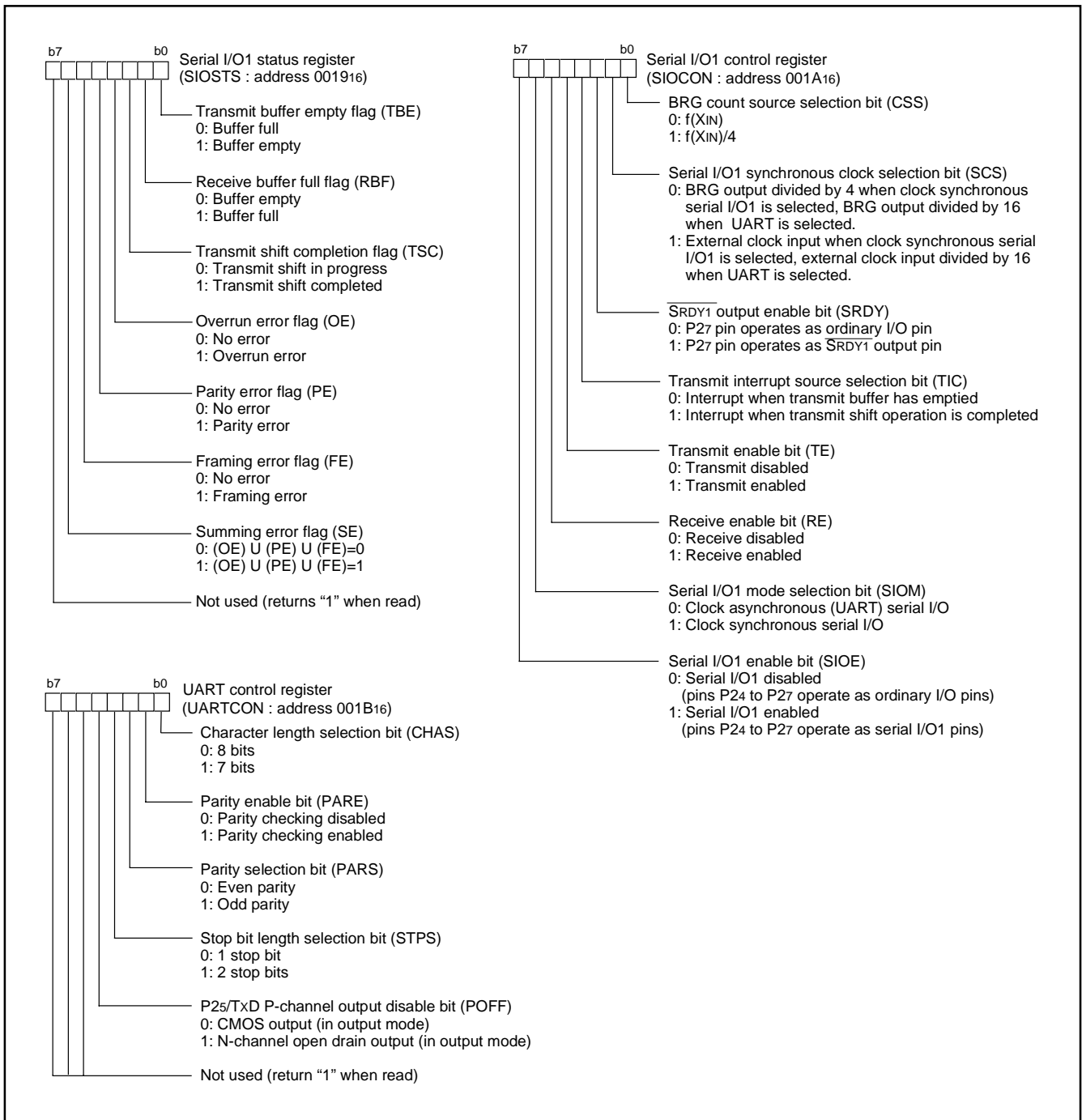

Fig. 24 Structure of serial I/O1 control registers

### ■Notes on serial I/O

When setting the transmit enable bit of serial I/O1 to "1", the serial I/O1 transmit interrupt request bit is automatically set to "1". When not requiring the interrupt occurrence synchronized with the transmission enabled, take the following sequence.

- (1) Set the serial I/O1 transmit interrupt enable bit to "0" (disabled).
- (2) Set the transmit enable bit to "1".
- (3) Set the serial I/O1 transmit interrupt request bit to "0" after 1 or more instructions have been executed.
- (4) Set the serial I/O1 transmit interrupt enable bit to "1" (enabled).

●SERIAL I/O2

The serial I/O2 can be operated only as the clock synchronous type. As a synchronous clock for serial transfer, either internal clock or external clock can be selected by the serial I/O2 synchronous clock selection bit (b6) of serial I/O2 control register 1.

The internal clock incorporates a dedicated divider and permits selecting 6 types of clock by the internal synchronous clock selection bits (b2, b1, b0) of serial I/O2 control register 1.

Regarding SOUT2 and SCLK2 being output pins, either CMOS output format or N-channel open-drain output format can be selected by the P01/SOUT2, P02/SCLK2 P-channel output disable bit (b7) of serial I/O2 control register 1.

When the internal clock has been selected, a transfer starts by a write signal to the serial I/O2 register (address 001716). After completion of data transfer, the level of the SOUT2 pin goes to high impedance automatically but bit 7 of the serial I/O2 control register 2 is not set to "1" automatically.

When the external clock has been selected, the contents of the serial I/O2 register is continuously shifted while transfer clocks are input. Accordingly, control the clock externally. Note that the SOUT2 pin does not go to high impedance after completion of data transfer.

To cause the SOUT2 pin to go to high impedance in the case where the external clock is selected, set bit 7 of the serial I/O2 control register 2 to "1" when SCLK2 is "H" after completion of data transfer. After the next data transfer is started (the transfer clock falls), bit 7 of the serial I/O2 control register 2 is set to "0" and the SOUT2 pin is put into the active state.

Regardless of the internal clock to external clock, the interrupt request bit is set after the number of bits (1 to 8 bits) selected by the optional transfer bit is transferred. In case of a fractional number of bits less than 8 bits as the last data, the received data to be stored in the serial I/O2 register becomes a fractional number of bits close to MSB if the transfer direction selection bit of serial I/O2 control register 1 is LSB first, or a fractional number of bits close to LSB if the transfer direction selection bit is MSB first. For the remaining bits, the previously received data is shifted.

At transmit operation using the clock synchronous serial I/O, the SCMP2 signal can be output by comparing the state of the transmit pin SOUT2 with the state of the receive pin SIN2 in synchronization with a rise of the transfer clock. If the output level of the SOUT2 pin is equal to the input level to the SIN2 pin, "L" is output from the SCMP2 pin. If not, "H" is output. At this time, an INT2 interrupt request can also be generated. Select a valid edge by bit 2 of the interrupt edge selection register (address 003A16).

[Serial I/O2 Control Registers 1, 2 (SIO2CON1 / SIO2CON2)] 001516, 001616

The serial I/O2 control registers 1 and 2 are containing various selection bits for serial I/O2 control as shown in Figure 25.

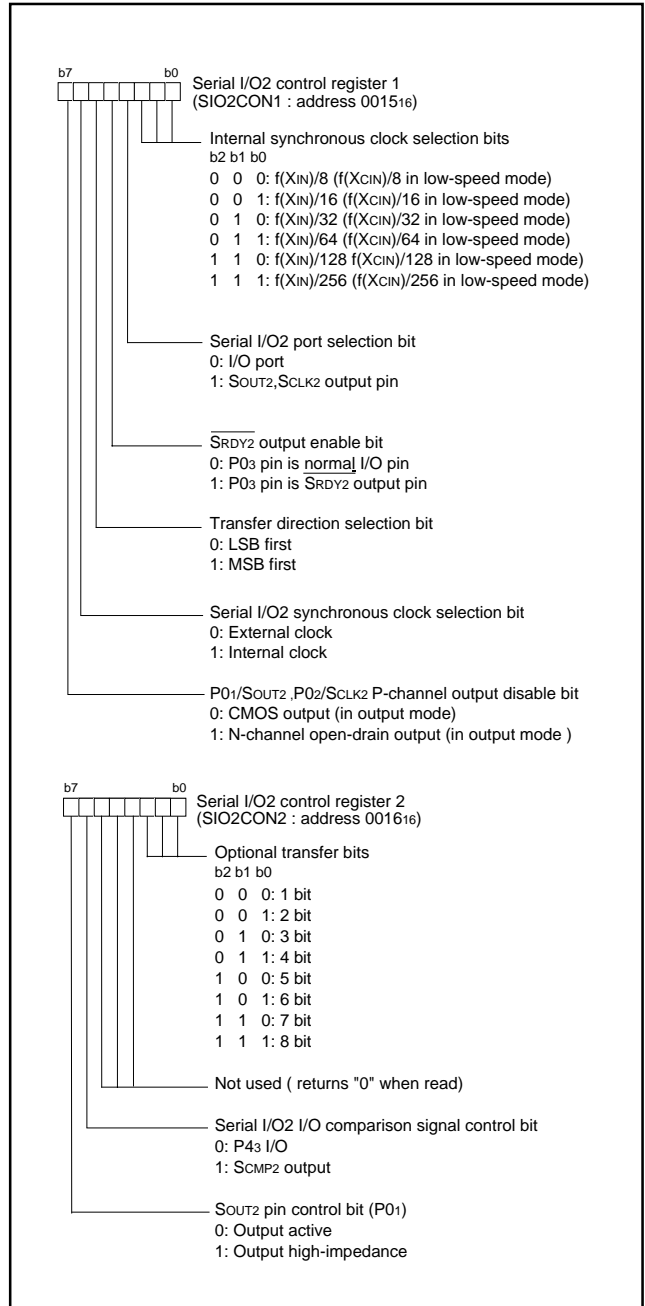

Fig. 25 Structure of Serial I/O2 control registers 1, 2

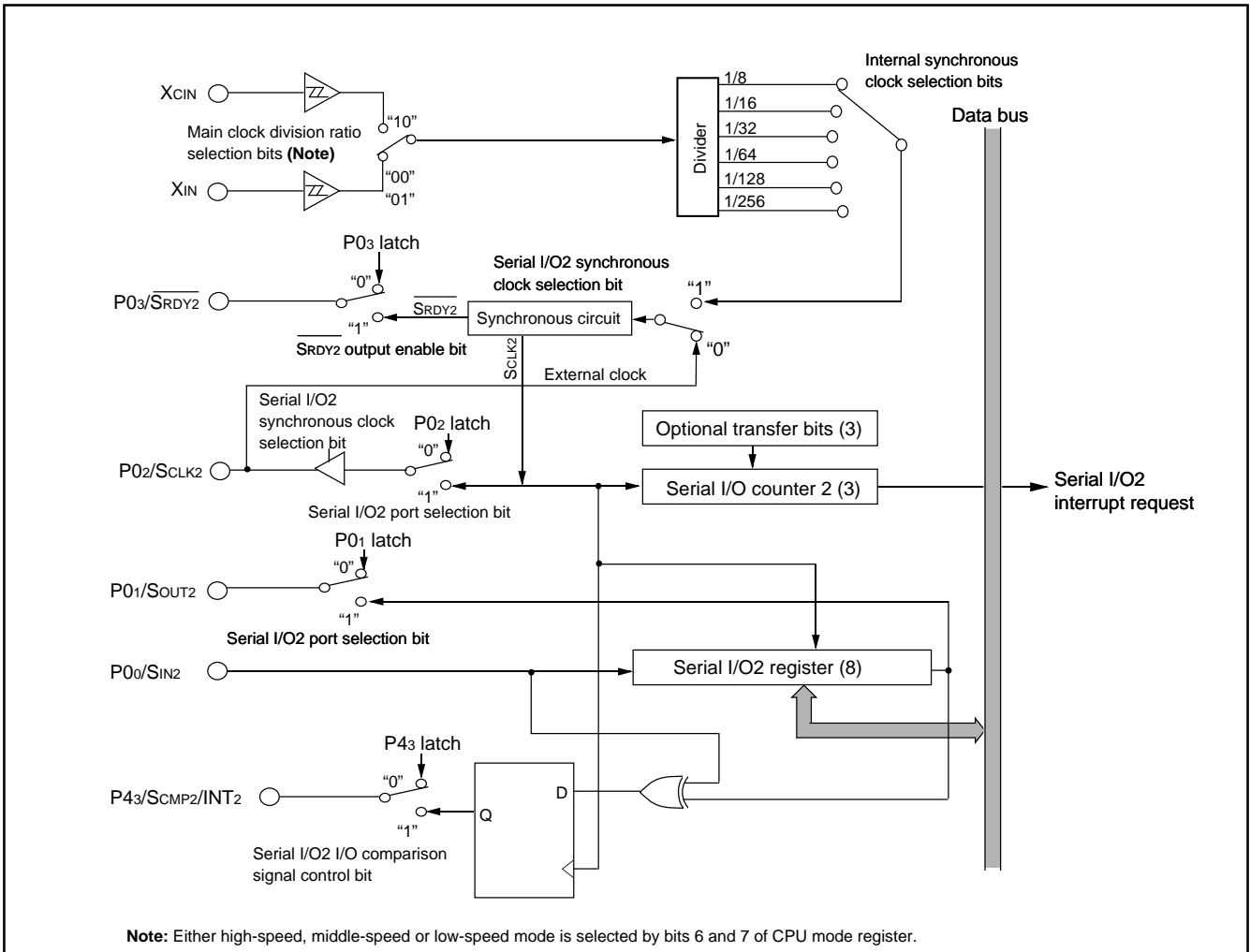

Fig. 26 Block diagram of Serial I/O2

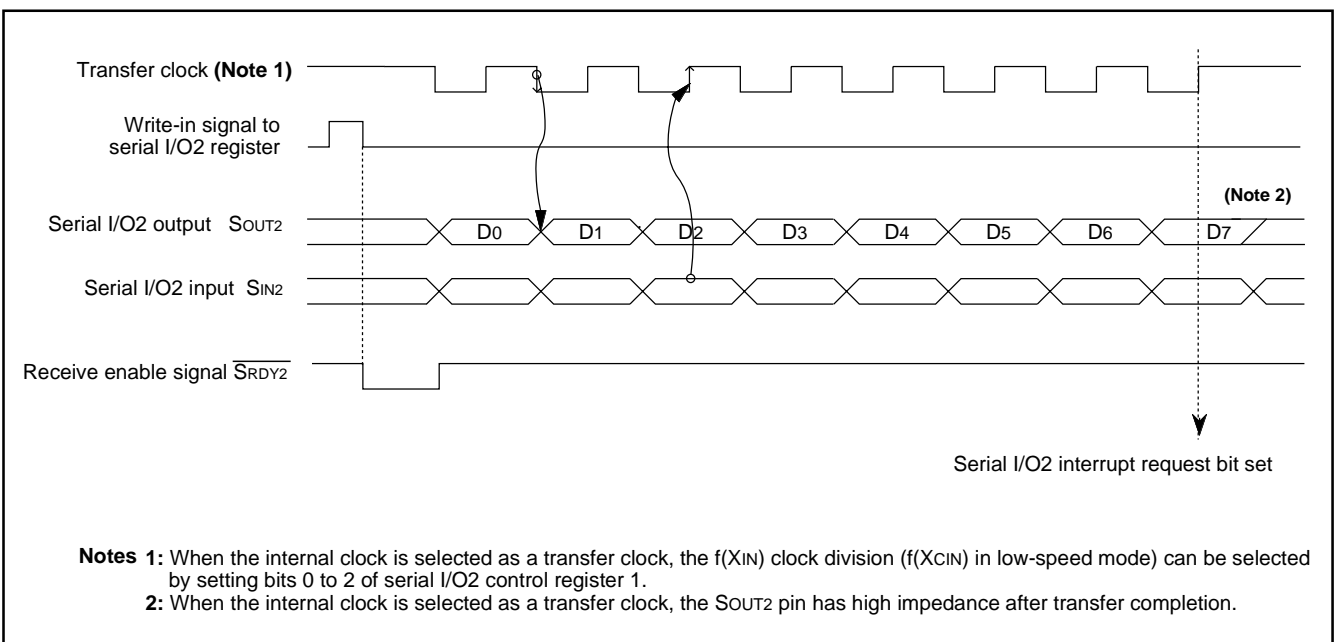

Fig. 27 Timing chart of Serial I/O2

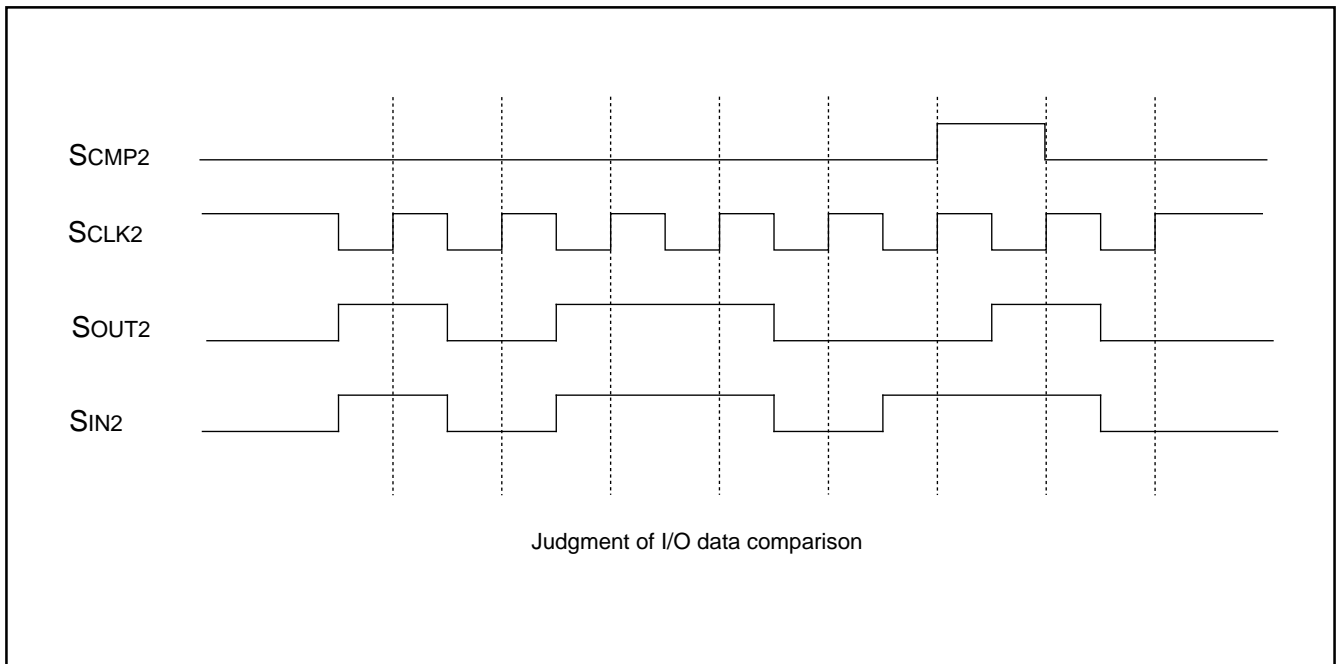

Fig. 28 Scmp2 output operation

### PULSE WIDTH MODULATION (PWM)

The 3850 group (spec. A) has a PWM function with an 8-bit resolution, based on a signal that is the clock input X<sub>IN</sub> or that clock input divided by 2.

#### Data Setting

The PWM output pin also functions as port P44. Set the PWM period by the PWM prescaler, and set the “H” term of output pulse by the PWM register.

If the value in the PWM prescaler is n and the value in the PWM register is m (where n = 0 to 255 and m = 0 to 255) :

$$\text{PWM period} = 255 \times (n+1) / f(\text{X}_{\text{IN}})$$

$$= 31.875 \times (n+1) \mu\text{s}$$

(when f(X<sub>IN</sub>) = 8 MHz, count source selection bit = “0”)

Output pulse “H” term = PWM period × m / 255

$$= 0.125 \times (n+1) \times m \mu\text{s}$$

(when f(X<sub>IN</sub>) = 8 MHz, count source selection bit = “0”)

### PWM Operation

When bit 0 (PWM enable bit) of the PWM control register is set to “1”, operation starts by initializing the PWM output circuit, and pulses are output starting at an “H”.

If the PWM register or PWM prescaler is updated during PWM output, the pulses will change in the cycle after the one in which the change was made.

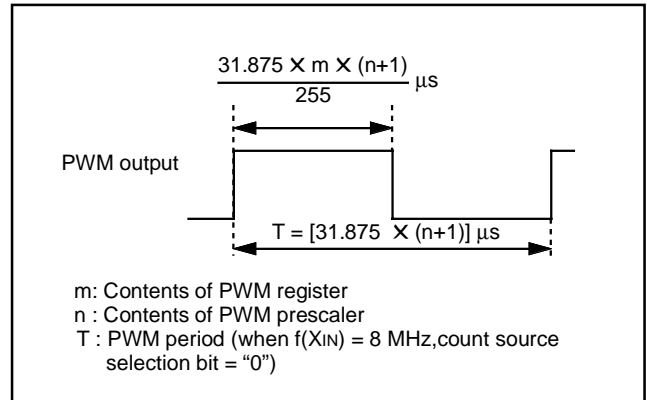

Fig. 29 Timing of PWM period

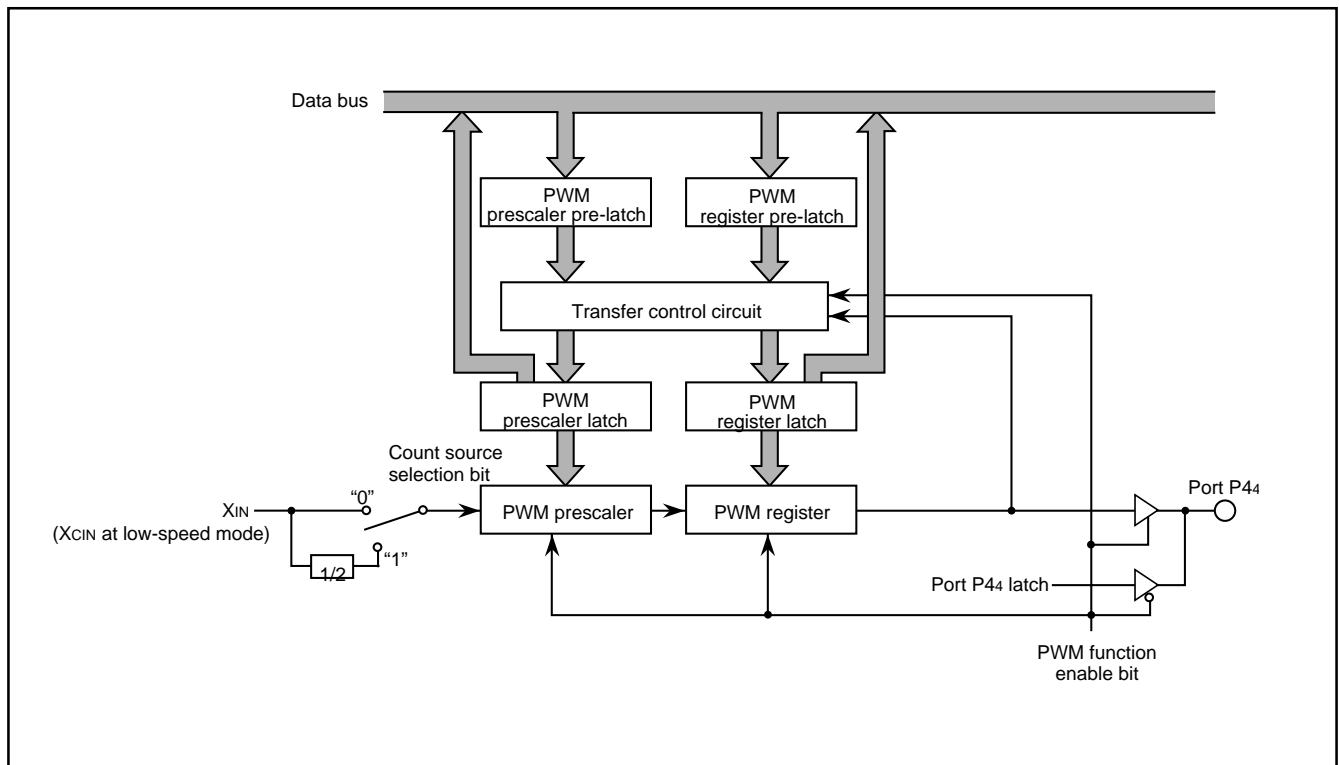

Fig. 30 Block diagram of PWM function

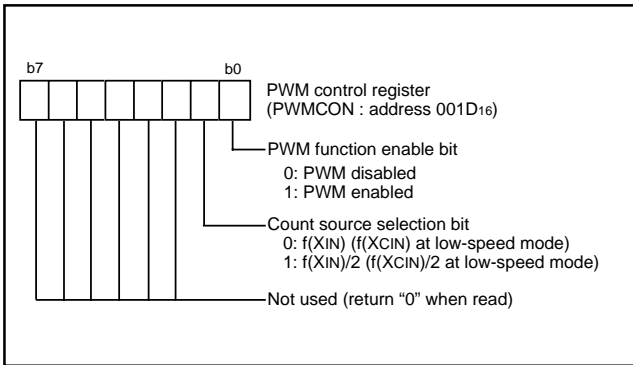

Fig. 31 Structure of PWM control register

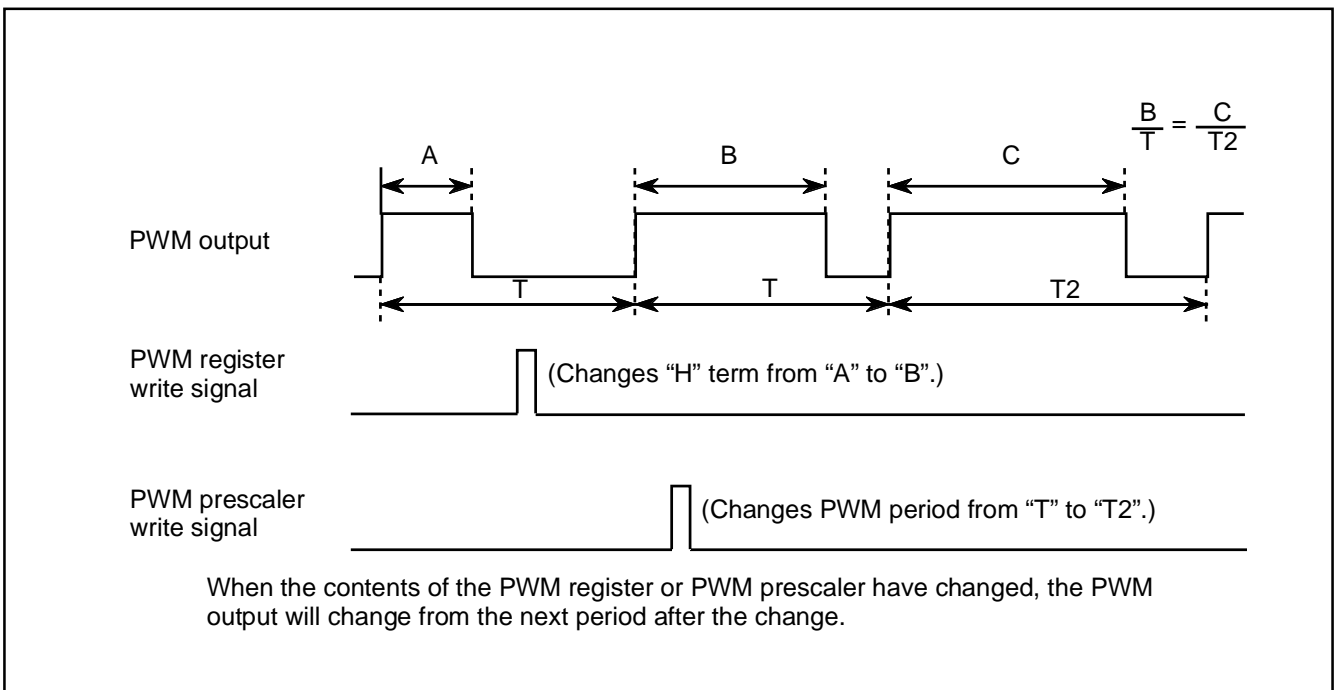

Fig. 32 PWM output timing when PWM register or PWM prescaler is changed

**Note**

The PWM starts after the PWM function enable bit is set to enable and "L" level is output from the PWM pin. The length of this "L" level output is as follows:

$$\frac{n+1}{2 \cdot f(X_{IN})} \text{ sec} \quad (\text{Count source selection bit} = 0, \text{ where } n \text{ is the value set in the prescaler})$$

$$\frac{n+1}{f(X_{IN})} \text{ sec} \quad (\text{Count source selection bit} = 1, \text{ where } n \text{ is the value set in the prescaler})$$



## A/D CONVERTER [AD Conversion Registers (ADL, ADH)] 003516, 003616

The AD conversion registers are read-only registers that store the result of an A/D conversion. Do not read these registers during an A/D conversion.

### [AD Control Register (ADCON)] 003416

The AD control register controls the A/D conversion process. Bits 0 to 2 select a specific analog input pin. By setting a value to these bits, when bit 0 of the AD input selection register (address 003716) is "0", P30/AN0-P34/AN4 can be selected, and when bit 0 of the AD input selection register is "1", P04/AN5-P07/AN8 can be selected. Bit 4 indicates the completion of an A/D conversion. The value of this bit remains at "0" during an A/D conversion and changes to "1" when an A/D conversion ends. Writing "0" to this bit starts the A/D conversion.

### [AD Input Selection Register (ADSEL)] 003716

The analog input port selection switch bit is assigned to bit 0 of the AD input selection register. When "0" is set to the analog input port selection switch bit, P30/AN0-P34/AN4 can be selected by the analog input pin selection bits (b2, b1, b0) of the AD control register (address 003416). When "1" is set to the analog input port selection switch bit, P04/AN5-P07/AN8 can be selected by the analog input pin selection bits (b2, b1, b0) of the AD control register (address 003416).

### Comparison Voltage Generator

The comparison voltage generator divides the voltage between AVSS and VREF into 1024 and outputs the divided voltages.

### Channel Selector

The channel selector selects one of ports P30/AN0 to P34/AN4, P04/AN5 to P07/AN8 and inputs the voltage to the comparator.

### Comparator and Control Circuit

The comparator and control circuit compare an analog input voltage with the comparison voltage, and the result is stored in the AD conversion registers. When an A/D conversion is completed, the control circuit sets the AD conversion completion bit and the AD interrupt request bit to "1".

Note that because the comparator consists of a capacitor coupling, set  $f(X_{IN})$  to 500 kHz or more during an A/D conversion.

When the A/D converter is operated at low-speed mode,  $f(X_{IN})$  and  $f(X_{CIN})$  do not have the lower limit of frequency, because of the A/D converter has a built-in self-oscillation circuit.

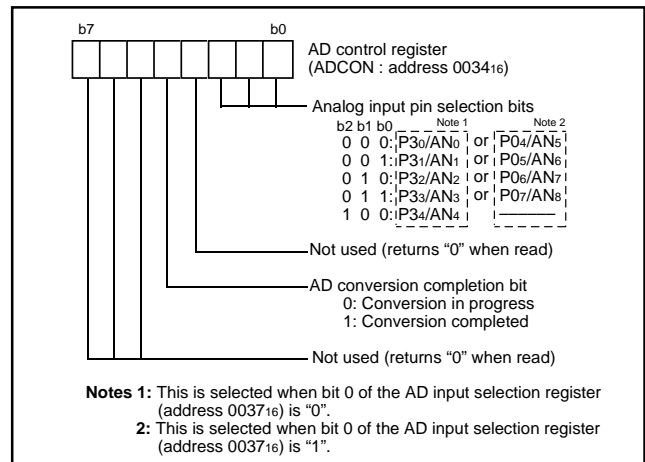

Fig. 33 Structure of AD control register

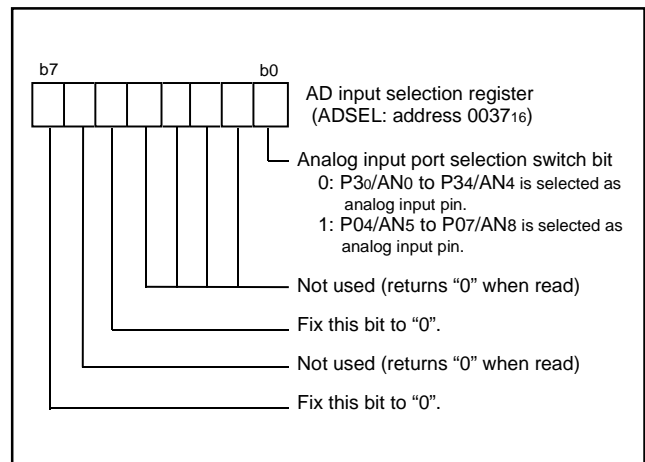

Fig. 34 Structure of AD input selection register

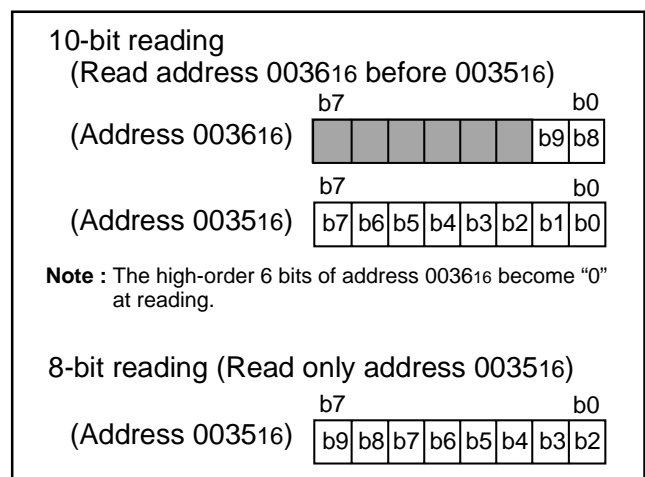

Fig. 35 Structure of AD conversion registers

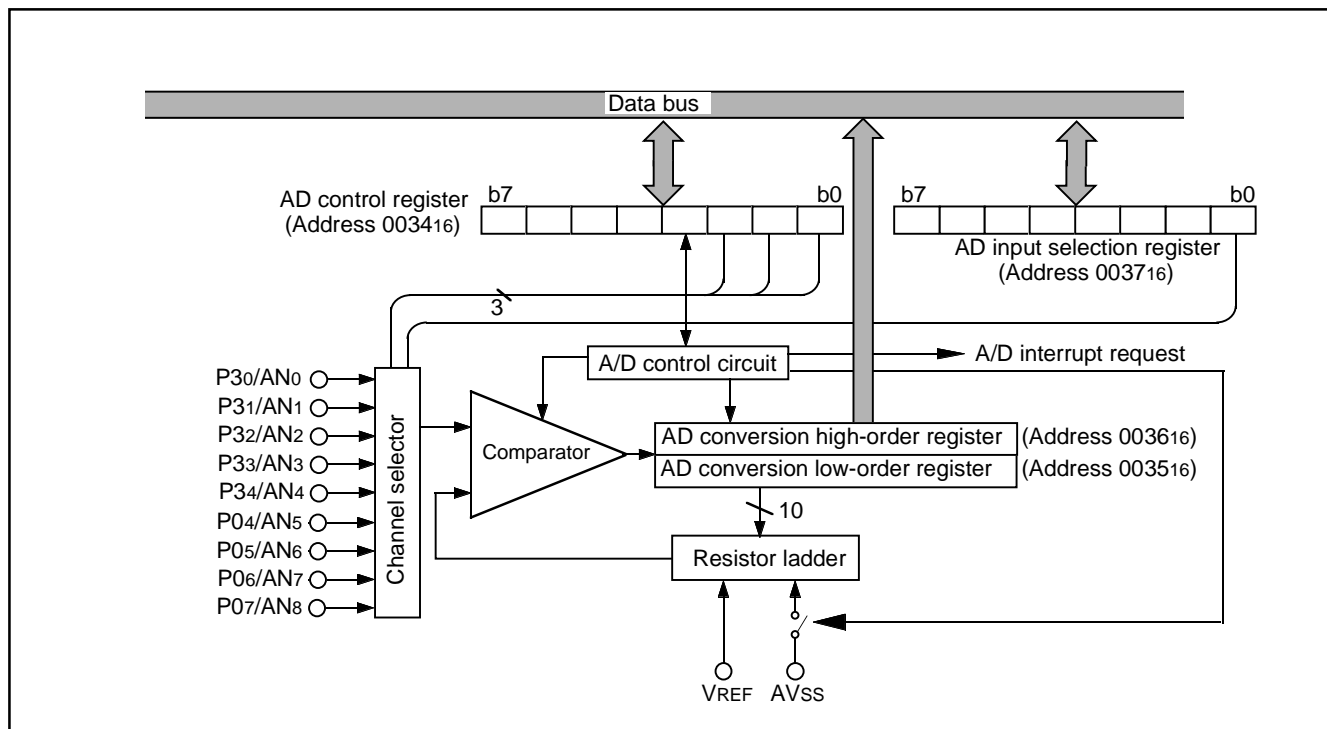

Fig. 36 Block diagram of A/D converter

### WATCHDOG TIMER

The watchdog timer gives a mean of returning to the reset status when a program cannot run on a normal loop (for example, because of a software run-away). The watchdog timer consists of an 8-bit watchdog timer L and an 8-bit watchdog timer H.

#### Initial Value of Watchdog Timer

At reset or writing to the watchdog timer control register (address 0039<sub>16</sub>), each of watchdog timer H and L is set to "FF<sub>16</sub>". Any instruction which generates a write signal such as the instructions of STA, LDM, CLB and others can be used to write. The data of bits 6 and 7 are only valid when writing to the watchdog timer control register. Each of watchdog timer is set to "FF<sub>16</sub>" regardless of the written data of bits 0 to 5.

#### Operation of Watchdog Timer

The watchdog timer stops at reset and starts to count down by writing to the watchdog timer control register. An internal reset occurs at an underflow of the watchdog timer H. The reset is released after waiting for a reset release time and the program is processed from the reset vector address. Accordingly, programming is usually performed so that writing to the watchdog timer control register may be started before an underflow of the watchdog timer H. If writing to the watchdog timer control register is not performed once, the watchdog timer does not function.

#### Bit 6 of Watchdog Timer Control Register

When bit 6 of the watchdog timer control register is "0", the MCU enters the stop mode by execution of STP instruction. Just after releasing the stop mode, the watchdog timer restarts counting (Note). When executing the WIT instruction, the watchdog timer does not stop.

When bit 6 is "1", execution of STP instruction causes an internal reset. When this bit is set to "1" once, it cannot be rewritten to "0" by program. Bit 6 is "0" at reset.

The necessary time after writing to the watchdog timer control register to an underflow of the watchdog timer H is shown as follows.

When bit 7 of the watchdog timer control register is "0":

- 32 s at X<sub>CIN</sub> = 32.768 kHz frequency and
- 65.536 ms at X<sub>IN</sub> = 16 MHz frequency.

When bit 7 of the watchdog timer control register is "1":

- 125 ms at X<sub>CIN</sub> = 32.768 kHz frequency and
- 256 μs at X<sub>IN</sub> = 16 MHz frequency.

Note: The watchdog timer continues to count for waiting for a stop mode release time. Do not generate an underflow of the watchdog timer H during that time.

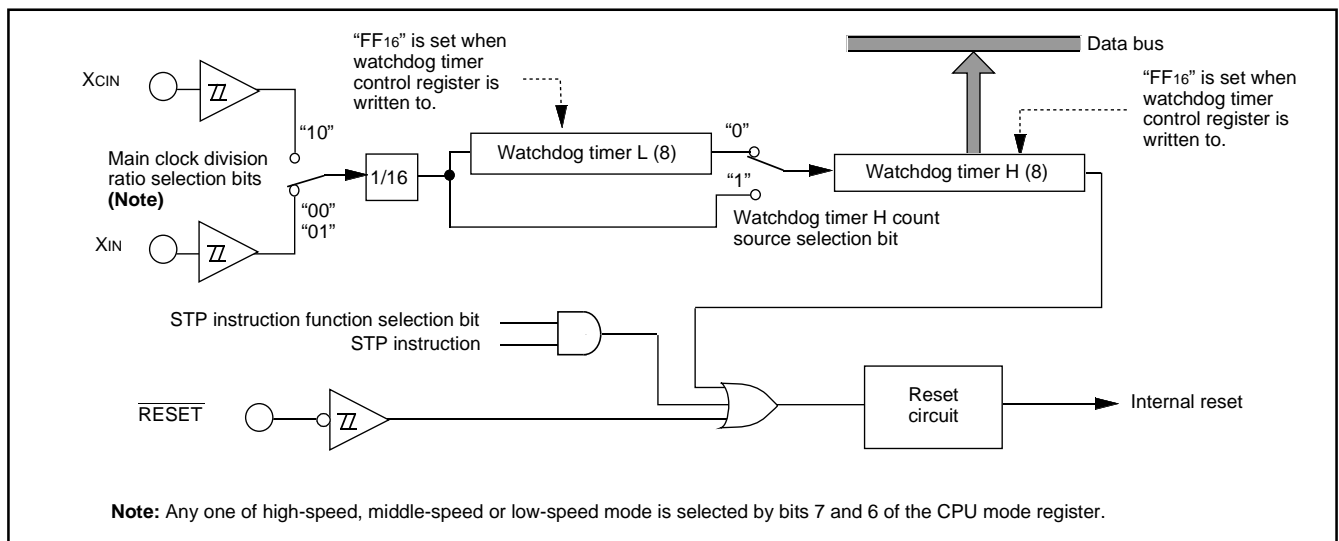

Fig. 37 Block diagram of Watchdog timer

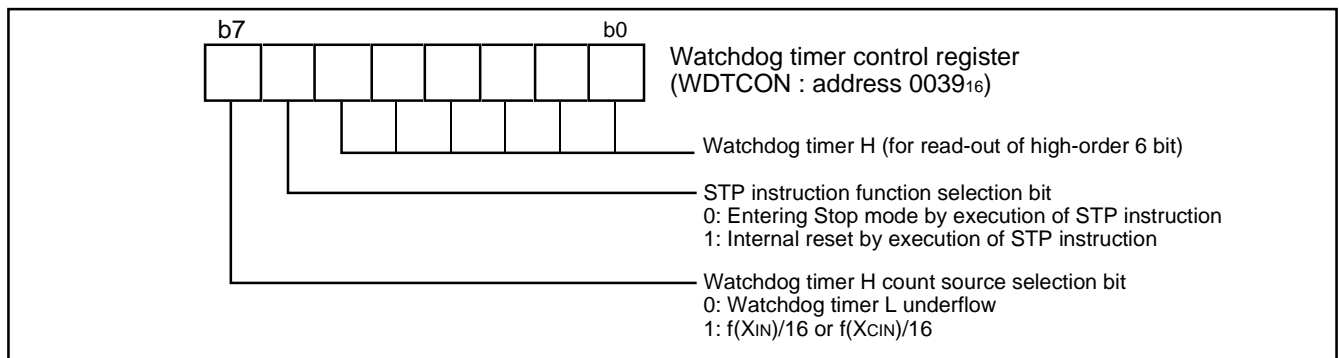

Fig. 38 Structure of Watchdog timer control register

### RESET CIRCUIT

To reset the microcomputer,  $\overline{\text{RESET}}$  pin must be held at an "L" level for 20 cycles or more of  $X_{\text{IN}}$ . Then the  $\overline{\text{RESET}}$  pin is returned to an "H" level (the power source voltage must be between 2.7 V and 5.5 V, and the oscillation must be stable), reset is released. After the reset is completed, the program starts from the address FFFC<sub>16</sub> (high-order byte) and address FFFD<sub>16</sub> (low-order byte). Make sure that the reset input voltage is less than 0.54 V for  $V_{\text{CC}}$  of 2.7 V.

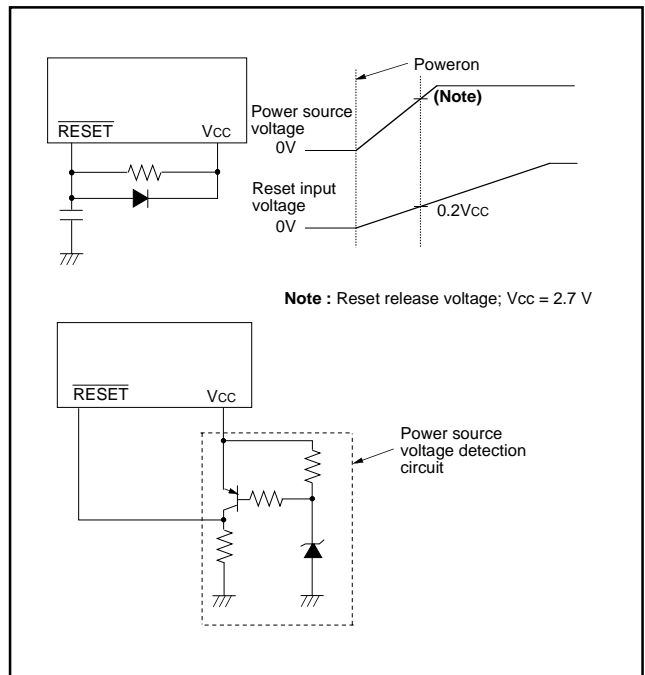

Fig. 39 Reset circuit example

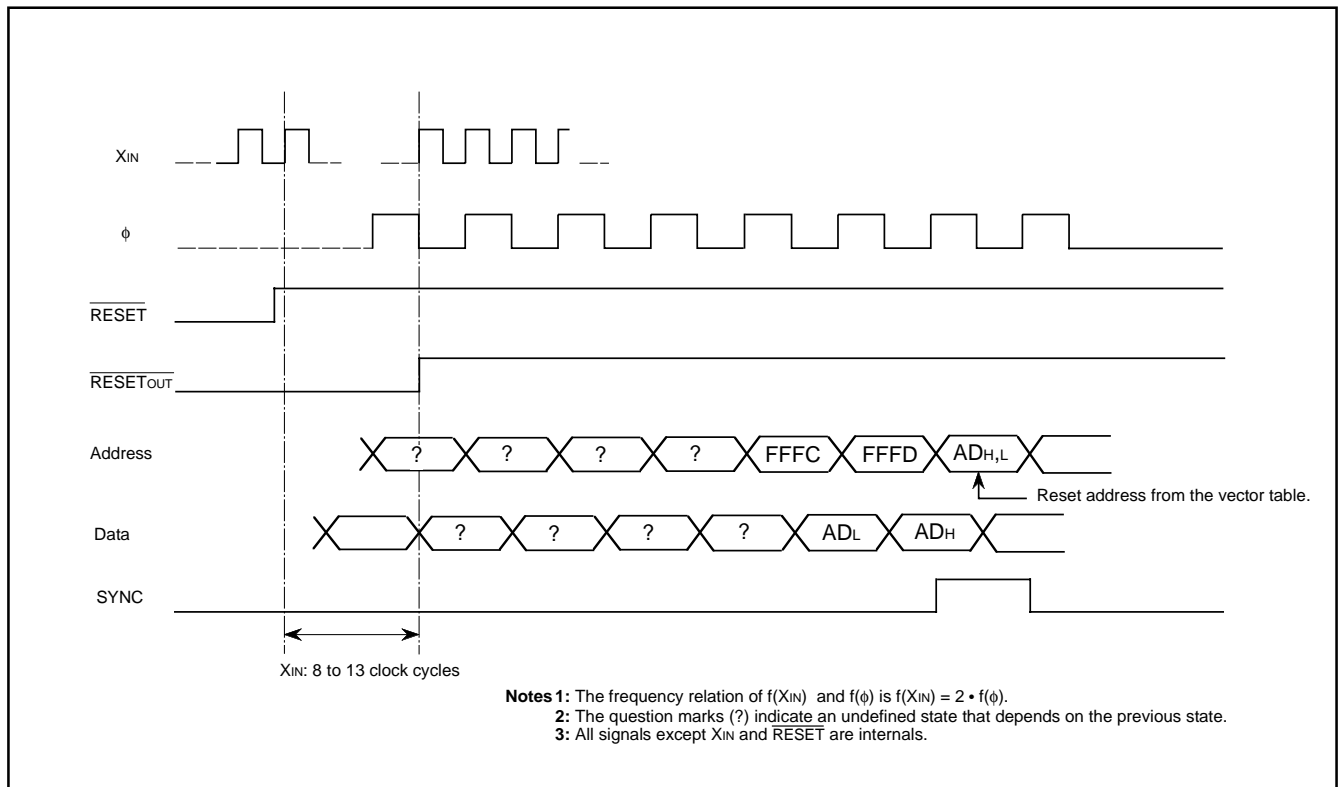

Fig. 40 Reset sequence

	Address	Register contents		Address	Register contents
(1) Port P0 (P0)	0000 <sub>16</sub>	00 <sub>16</sub>	(34) AD control register (ADCON)	0034 <sub>16</sub>	00010100000
(2) Port P0 direction register (P0D)	0001 <sub>16</sub>	00 <sub>16</sub>	(35) AD conversion low-order register (ADL)	0035 <sub>16</sub>	XXXXXXXXXX
(3) Port P1 (P1)	0002 <sub>16</sub>	00 <sub>16</sub>	(36) AD conversion high-order register (ADH)	0036 <sub>16</sub>	00000000XX
(4) Port P1 direction register (P1D)	0003 <sub>16</sub>	00 <sub>16</sub>	(37) AD input selection register (ADSEL)	0037 <sub>16</sub>	00 <sub>16</sub>
(5) Port P2 (P2)	0004 <sub>16</sub>	00 <sub>16</sub>	(38) MISRG	0038 <sub>16</sub>	00 <sub>16</sub>
(6) Port P2 direction register (P2D)	0005 <sub>16</sub>	00 <sub>16</sub>	(39) Watchdog timer control register (WDTCON)	0039 <sub>16</sub>	001111111
(7) Port P3 (P3)	0006 <sub>16</sub>	00 <sub>16</sub>	(40) Interrupt edge selection register (INTEDGE)	003A <sub>16</sub>	00 <sub>16</sub>
(8) Port P3 direction register (P3D)	0007 <sub>16</sub>	00 <sub>16</sub>	(41) CPU mode register (CPUM)	003B <sub>16</sub>	010010000
(9) Port P4 (P4)	0008 <sub>16</sub>	00 <sub>16</sub>	(42) Interrupt request register 1 (IREQ1)	003C <sub>16</sub>	00 <sub>16</sub>
(10) Port P4 direction register (P4D)	0009 <sub>16</sub>	00 <sub>16</sub>	(43) Interrupt request register 2 (IREQ2)	003D <sub>16</sub>	00 <sub>16</sub>
(11) Port P0, P1, P2 pull-up control register (PULL012)	0012 <sub>16</sub>	00 <sub>16</sub>	(44) Interrupt control register 1 (ICON1)	003E <sub>16</sub>	00 <sub>16</sub>
(12) Port P3 pull-up control register (PULL3)	0013 <sub>16</sub>	00 <sub>16</sub>	(45) Interrupt control register 2 (ICON2)	003F <sub>16</sub>	00 <sub>16</sub>
(13) Port P4 pull-up control register (PULL4)	0014 <sub>16</sub>	00 <sub>16</sub>	(46) Processor status register	(PS)	XXXXXXXX1X
(14) Serial I/O2 control register 1 (SIO2CON1)	0015 <sub>16</sub>	00 <sub>16</sub>	(47) Program counter	(PC <sub>H</sub> )	FFF <sub>16</sub> contents
(15) Serial I/O2 control register 2 (SIO2CON2)	0016 <sub>16</sub>	000000111		(PC <sub>L</sub> )	FFC <sub>16</sub> contents
(16) Serial I/O2 register (SIO2)	0017 <sub>16</sub>	XXXXXXXX			
(17) Transmit/Receive buffer register (TB/RB)	0018 <sub>16</sub>	XXXXXXXX			
(18) Serial I/O1 status register (SIOSTS)	0019 <sub>16</sub>	10000000			
(19) Serial I/O1 control register (SIOCON)	001A <sub>16</sub>	00 <sub>16</sub>			
(20) UART control register (UARTCON)	001B <sub>16</sub>	11100000			
(21) Baud rate generator (BRG)	001C <sub>16</sub>	XXXXXXXX			
(22) PWM control register (PWMCON)	001D <sub>16</sub>	00 <sub>16</sub>			
(23) PWM prescaler (PREPWM)	001E <sub>16</sub>	XXXXXXXX			
(24) PWM register (PWM)	001F <sub>16</sub>	XXXXXXXX			
(25) Prescaler 12 (PRE12)	0020 <sub>16</sub>	FF <sub>16</sub>			
(26) Timer 1 (T1)	0021 <sub>16</sub>	01 <sub>16</sub>			
(27) Timer 2 (T2)	0022 <sub>16</sub>	00 <sub>16</sub>			
(28) Timer XY mode register (TM)	0023 <sub>16</sub>	00 <sub>16</sub>			
(29) Prescaler X (PREX)	0024 <sub>16</sub>	FF <sub>16</sub>			
(30) Timer X (TX)	0025 <sub>16</sub>	FF <sub>16</sub>			
(31) Prescaler Y (PREY)	0026 <sub>16</sub>	FF <sub>16</sub>			
(32) Timer Y (TY)	0027 <sub>16</sub>	FF <sub>16</sub>			
(33) Timer count source selection register (TCSS)	0028 <sub>16</sub>	00 <sub>16</sub>			

**Note** : X : Not fixed  
 Since the initial values for other than above mentioned registers and RAM contents are indefinite at reset, they must be set.

Fig. 41 Internal status at reset

### CLOCK GENERATING CIRCUIT

The 3850 group (spec. A) has two built-in oscillation circuits. An oscillation circuit can be formed by connecting a resonator between XIN and XOUT (XCIN and XCOU). Use the circuit constants in accordance with the resonator manufacturer's recommended values. No external resistor is needed between XIN and XOUT since a feed-back resistor exists on-chip.(An external feed-back resistor may be needed depending on conditions.) However, an external feed-back resistor is needed between XCIN and XCOU. Immediately after power on, only the XIN oscillation circuit starts oscillating, and XCIN and XCOU pins function as I/O ports.

### Frequency Control

#### (1) Middle-speed mode

The internal clock  $\phi$  is the frequency of XIN divided by 8. After reset is released, this mode is selected.

#### (2) High-speed mode

The internal clock  $\phi$  is half the frequency of XIN.

#### (3) Low-speed mode

The internal clock  $\phi$  is half the frequency of XCIN.

#### (4) Low power dissipation mode

The low power consumption operation can be realized by stopping the main clock XIN in low-speed mode. To stop the main clock, set bit 5 of the CPU mode register to "1". When the main clock XIN is restarted (by setting the main clock stop bit to "0"), set sufficient time for oscillation to stabilize.

The sub-clock XCIN-XCOU oscillating circuit can not directly input clocks that are generated externally. Accordingly, make sure to cause an external resonator to oscillate.

### Oscillation Control

#### (1) Stop mode

If the STP instruction is executed, the internal clock  $\phi$  stops at an "H" level, and XIN and XCIN oscillation stops. When the oscillation stabilizing time set after STP instruction released bit (bit 0 of address 003816) is "0", the prescaler 12 is set to "FF16" and timer 1 is set to "0116". When the oscillation stabilizing time set after STP instruction released bit is "1", set the sufficient time for oscillation of used oscillator to stabilize since nothing is set to the prescaler 12 and timer 1.

After STP instruction is released, the input of the prescaler 12 is connected to count source which had set at executing the STP instruction, and the output of the prescaler 12 is connected to timer 1. Oscillator restarts when an external interrupt is received, but the internal clock  $\phi$  is not supplied to the CPU (remains at "H") until timer 1 underflows. The internal clock  $\phi$  is supplied for the first time, when timer 1 underflows. This ensures time for the clock oscillation using the ceramic resonators to be stabilized. When the oscillator is restarted by reset, apply "L" level to the  $\overline{\text{RESET}}$  pin until the oscillation is stable since a wait time will not be generated.

#### (2) Wait mode

If the WIT instruction is executed, the internal clock  $\phi$  stops at an "H" level, but the oscillator does not stop. The internal clock  $\phi$  restarts at reset or when an interrupt is received. Since the oscillator does not stop, normal operation can be started immediately after the clock is restarted.

To ensure that the interrupts will be received to release the STP or WIT state, their interrupt enable bits must be set to "1" before executing of the STP or WIT instruction.

When releasing the STP state, the prescaler 12 and timer 1 will start counting the clock XIN divided by 16. Accordingly, set the timer 1 interrupt enable bit to "0" before executing the STP instruction.

### Note

- If you switch the mode between middle/high-speed and low-speed, stabilize both XIN and XCIN oscillations. The sufficient time is required for the sub-clock to stabilize, especially immediately after power on and at returning from the stop mode. When switching the mode between middle/high-speed and low-speed, set the frequency on condition that  $f(\text{XIN}) > 3 \cdot f(\text{XCIN})$ .
- When using the oscillation stabilizing time set after STP instruction released bit set to "1", evaluate time to stabilize oscillation of the used oscillator and set the value to the timer 1 and prescaler 12.

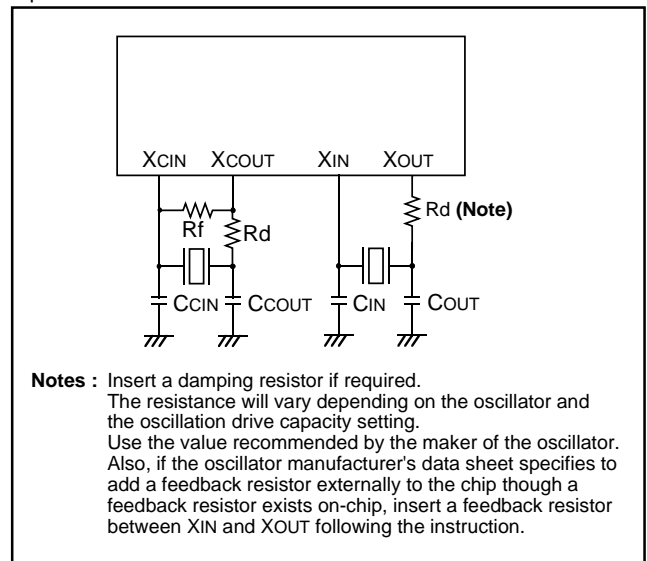

Fig. 42 Ceramic resonator circuit

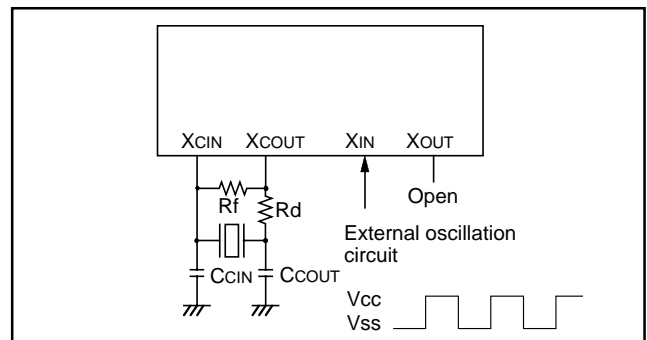

Fig. 43 External clock input circuit

**[MISRG (MISRG)] 003816**

MISRG consists of three control bits (bits 1 to 3) for middle-speed mode automatic switch and one control bit (bit 0) for oscillation stabilizing time set after STP instruction released.

By setting the middle-speed mode automatic switch start bit to "1" while operating in the low-speed mode and setting the middle-speed mode automatic switch set bit to "1", XIN oscillation automatically starts and the mode is automatically switched to the middle-speed mode.

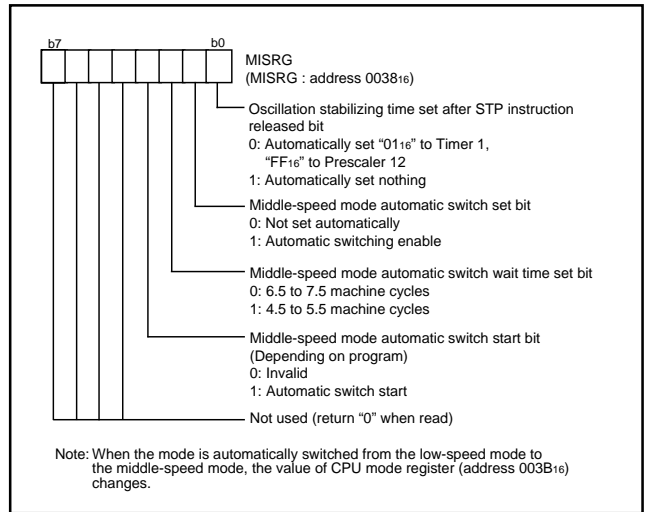

Fig. 44 Structure of MISRG

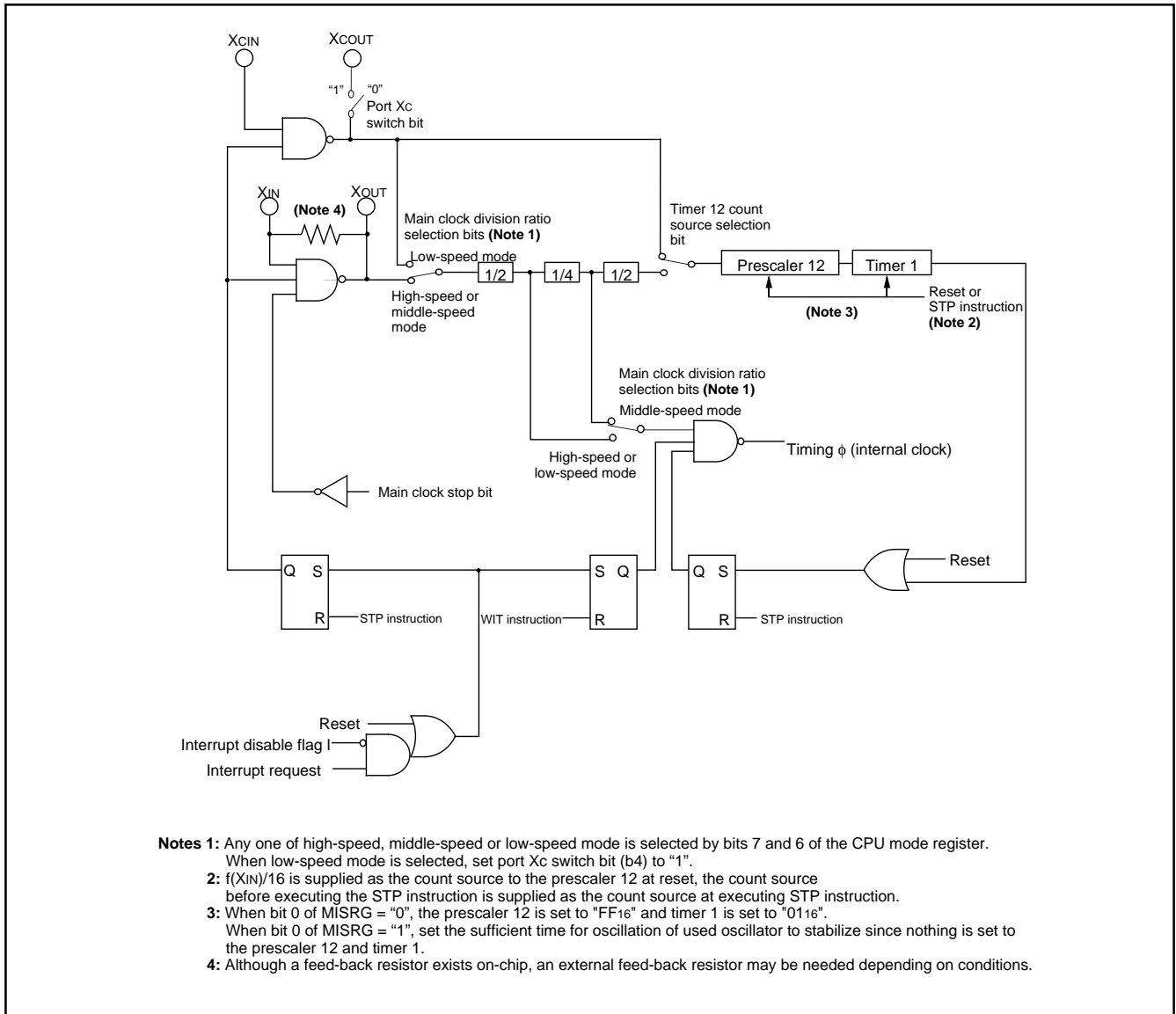
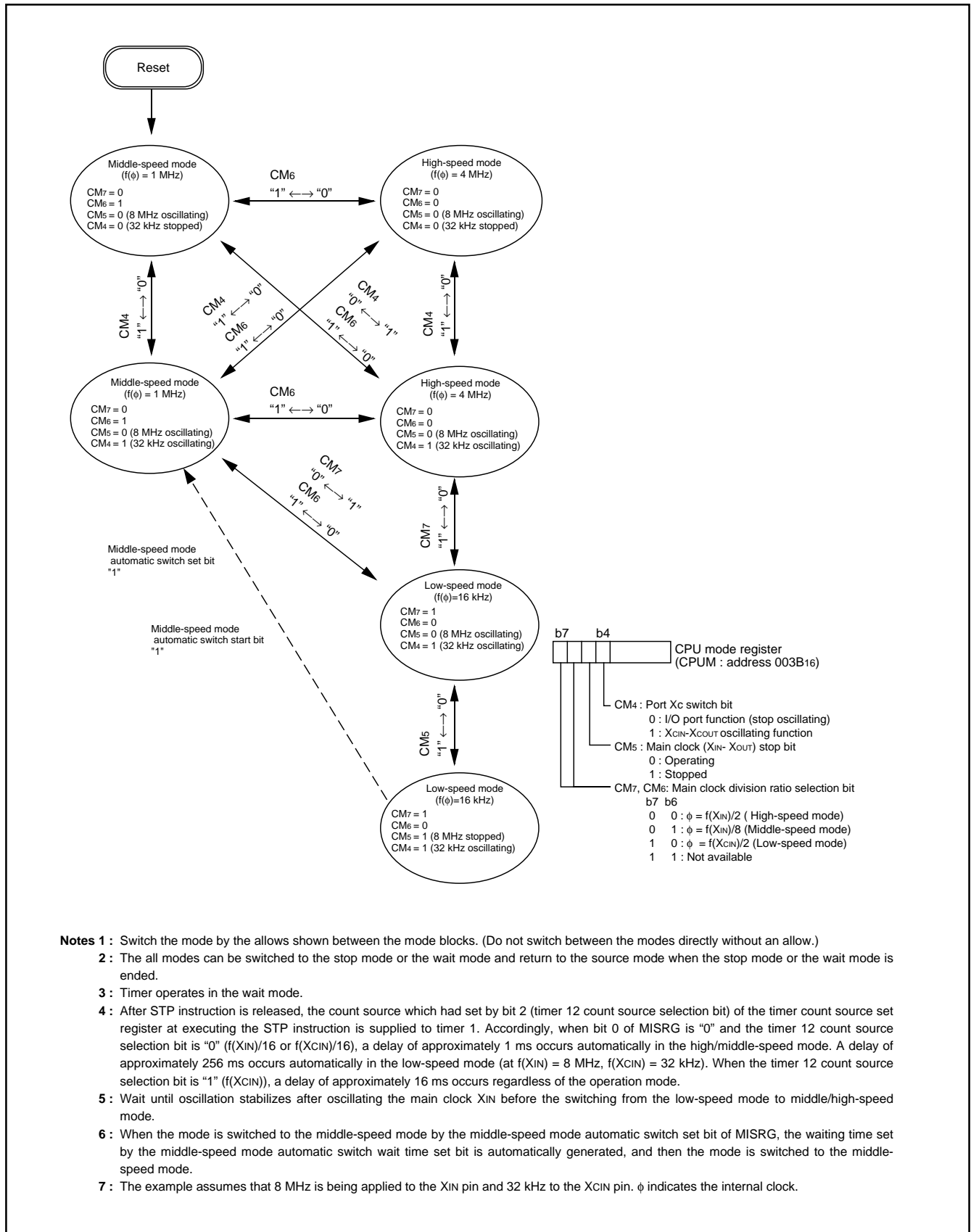

Fig. 45 System clock generating circuit block diagram (Single-chip mode)



- Notes 1 :** Switch the mode by the allows shown between the mode blocks. (Do not switch between the modes directly without an allow.)
- 2 :** The all modes can be switched to the stop mode or the wait mode and return to the source mode when the stop mode or the wait mode is ended.
- 3 :** Timer operates in the wait mode.
- 4 :** After STP instruction is released, the count source which had set by bit 2 (timer 12 count source selection bit) of the timer count source set register at executing the STP instruction is supplied to timer 1. Accordingly, when bit 0 of MISRG is "0" and the timer 12 count source selection bit is "0" (f(XIN)/16 or f(XCIN)/16), a delay of approximately 1 ms occurs automatically in the high/middle-speed mode. A delay of approximately 256 ms occurs automatically in the low-speed mode (at f(XIN) = 8 MHz, f(XCIN) = 32 kHz). When the timer 12 count source selection bit is "1" (f(XCIN)), a delay of approximately 16 ms occurs regardless of the operation mode.
- 5 :** Wait until oscillation stabilizes after oscillating the main clock XIN before the switching from the low-speed mode to middle/high-speed mode.
- 6 :** When the mode is switched to the middle-speed mode by the middle-speed mode automatic switch set bit of MISRG, the waiting time set by the middle-speed mode automatic switch wait time set bit is automatically generated, and then the mode is switched to the middle-speed mode.
- 7 :** The example assumes that 8 MHz is being applied to the XIN pin and 32 kHz to the XCIN pin. φ indicates the internal clock.

Fig. 46 State transitions of system clock



## FLASH MEMORY MODE

The M38507F8A (flash memory version) has an internal new DINOR (Divided bit line NOR) flash memory that can be rewritten with a single power source when  $V_{CC}$  is 5 V, and 2 power sources when  $V_{PP}$  is 5 V and  $V_{CC}$  is 3.0-5.5 V in the CPU rewrite and standard serial I/O modes.

For this flash memory, three flash memory modes are available in which to read, program, and erase: the parallel I/O and standard serial I/O modes in which the flash memory can be manipulated using a programmer and the CPU rewrite mode in which the flash memory can be manipulated by the Central Processing Unit (CPU).

## Summary

Table 8 lists the summary of the M38507F8A (flash memory version).

The flash memory of the M38507F8 is divided into User ROM area and Boot ROM area as shown in Figure 47.

In addition to the ordinary User ROM area to store the MCU operation control program, the flash memory has a Boot ROM area that is used to store a program to control rewriting in CPU rewrite and standard serial I/O modes. This Boot ROM area has had a standard serial I/O mode control program stored in it when shipped from the factory. However, the user can write a rewrite control program in this area that suits the user's application system. This Boot ROM area can be rewritten in only parallel I/O mode.

**Table 8 Summary of M38507F8A (flash memory version)**

Item		Specifications
Power source voltage		$V_{CC} = 2.7 - 5.5$ V ( <b>Note 1</b> ) $V_{CC} = 2.7 - 3.6$ V ( <b>Note 2</b> )
VPP voltage (For Program/Erase)		4.5-5.5 V
Flash memory mode		3 modes (Parallel I/O mode, Standard serial I/O mode, CPU rewrite mode)
Erase block division	User ROM area	1 block (32 Kbytes)
	Boot ROM area	1 block (4 Kbytes) ( <b>Note 3</b> )
Program method		Byte program
Erase method		Batch erasing
Program/Erase control method		Program/Erase control by software command
Number of commands		6 commands
Number of program/Erase times		100 times
ROM code protection		Available in parallel I/O mode and standard serial I/O mode

**Notes 1:** The power source voltage must be  $V_{CC} = 4.5 - 5.5$  V at program and erase operation.

**2:** The power source voltage can be  $V_{CC} = 3.0 - 3.6$  V also at program and erase operation.

**3:** The Boot ROM area has had a standard serial I/O mode control program stored in it when shipped from the factory. This Boot ROM area can be rewritten in only parallel I/O mode.

### (1) CPU Rewrite Mode

In CPU rewrite mode, the internal flash memory can be operated on (read, program, or erase) under control of the Central Processing Unit (CPU).

In CPU rewrite mode, only the User ROM area shown in Figure 47 can be rewritten; the Boot ROM area cannot be rewritten. Make sure the program and block erase commands are issued for only the User ROM area and each block area.

The control program for CPU rewrite mode can be stored in either User ROM or Boot ROM area. In the CPU rewrite mode, because the flash memory cannot be read from the CPU, the rewrite control program must be transferred to internal RAM area to be executed before it can be executed.

### Microcomputer Mode and Boot Mode

The control program for CPU rewrite mode must be written into the User ROM or Boot ROM area in parallel I/O mode beforehand. (If the control program is written into the Boot ROM area, the standard serial I/O mode becomes unusable.)

See Figure 47 for details about the Boot ROM area.

Normal microcomputer mode is entered when the microcomputer is reset with pulling CNVss pin low. In this case, the CPU starts operating using the control program in the User ROM area.

When the microcomputer is reset by pulling the P41/INT0 pin high, the CNVss pin high, the CPU starts operating using the control program in the Boot ROM area (program start address is FFFC<sub>16</sub>, FFFD<sub>16</sub> fixation). This mode is called the "Boot" mode.

### Block Address

Block addresses refer to the maximum address of each block. These addresses are used in the block erase command. In case of the M38507F8A, it has only one block.

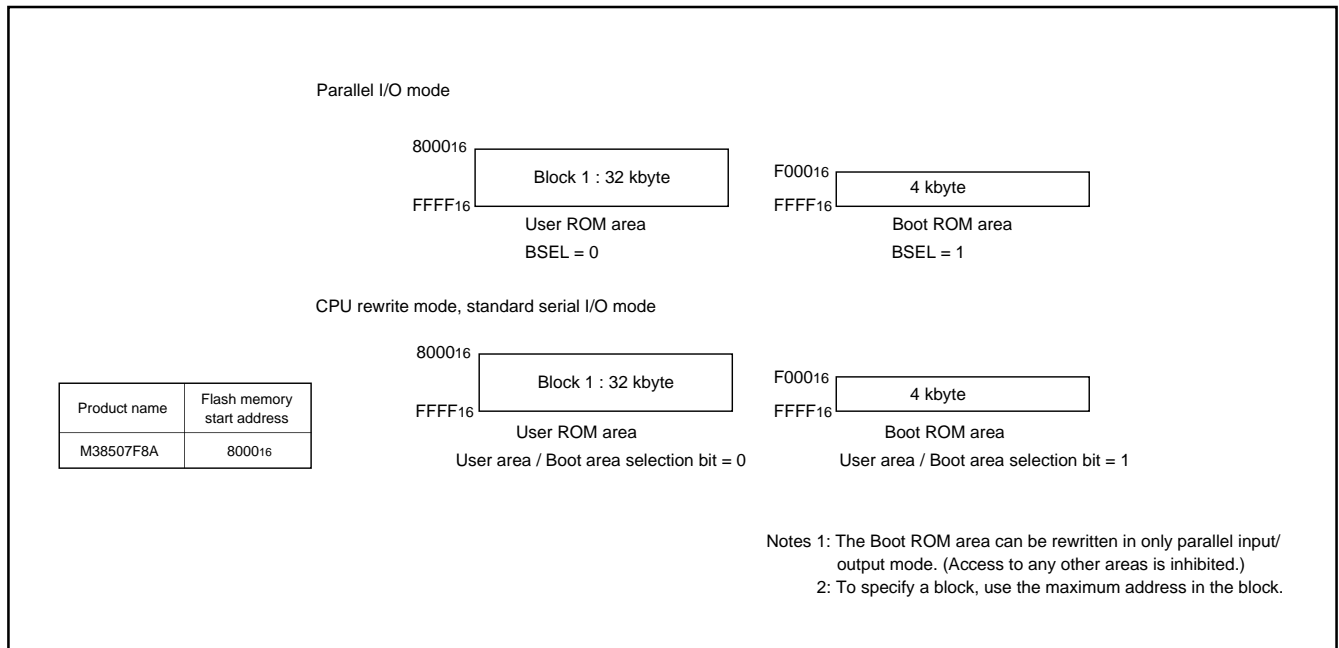

Fig. 47 Block diagram of built-in flash memory

## Outline Performance (CPU Rewrite Mode)

CPU rewrite mode is usable in the single-chip or Boot mode. The only User ROM area can be rewritten in CPU rewrite mode.

In CPU rewrite mode, the CPU erases, programs and reads the internal flash memory by executing software commands. This rewrite control program must be transferred to the RAM before it can be executed.

The MCU enters CPU rewrite mode by applying  $5\text{ V} \pm 0.5\text{ V}$  to the CNVSS pin and setting "1" to the CPU Rewrite Mode Select Bit (bit 1 of address 0FFE<sub>16</sub>). Software commands are accepted once the mode is entered.

Use software commands to control program and erase operations. Whether a program or erase operation has terminated normally or in error can be verified by reading the status register.

Figure 48 shows the flash memory control register.

Bit 0 is the RY/ $\overline{\text{BY}}$  status flag used exclusively to read the operating status of the flash memory. During programming and erase operations, it is "0" (busy). Otherwise, it is "1" (ready).

Bit 1 is the CPU Rewrite Mode Select Bit. When this bit is set to "1", the MCU enters CPU rewrite mode. Software commands are accepted once the mode is entered. In CPU rewrite mode, the CPU becomes unable to access the internal flash memory directly.

Therefore, use the control program in the RAM for write to bit 1. To set this bit to "1", it is necessary to write "0" and then write "1" in succession. The bit can be set to "0" by only writing "0".

Bit 2 is the CPU Rewrite Mode Entry Flag. This flag indicates "1" in CPU rewrite mode, so that reading this flag can check whether CPU rewrite mode has been entered or not.

Bit 3 is the flash memory reset bit used to reset the control circuit of internal flash memory. This bit is used when exiting CPU rewrite mode and when flash memory access has failed. When the CPU Rewrite Mode Select Bit is "1", setting "1" for this bit resets the control circuit. To set this bit to "1", it is necessary to write "0" and then write "1" in succession. To release the reset, it is necessary to set this bit to "0".

Bit 4 is the User Area/Boot Area Select Bit. When this bit is set to "1", Boot ROM area is accessed, and CPU rewrite mode in Boot ROM area is available. In Boot mode, this bit is set to "1" automatically. Reprogramming of this bit must be in the RAM.

Figure 49 shows a flowchart for setting/releasing CPU rewrite mode.

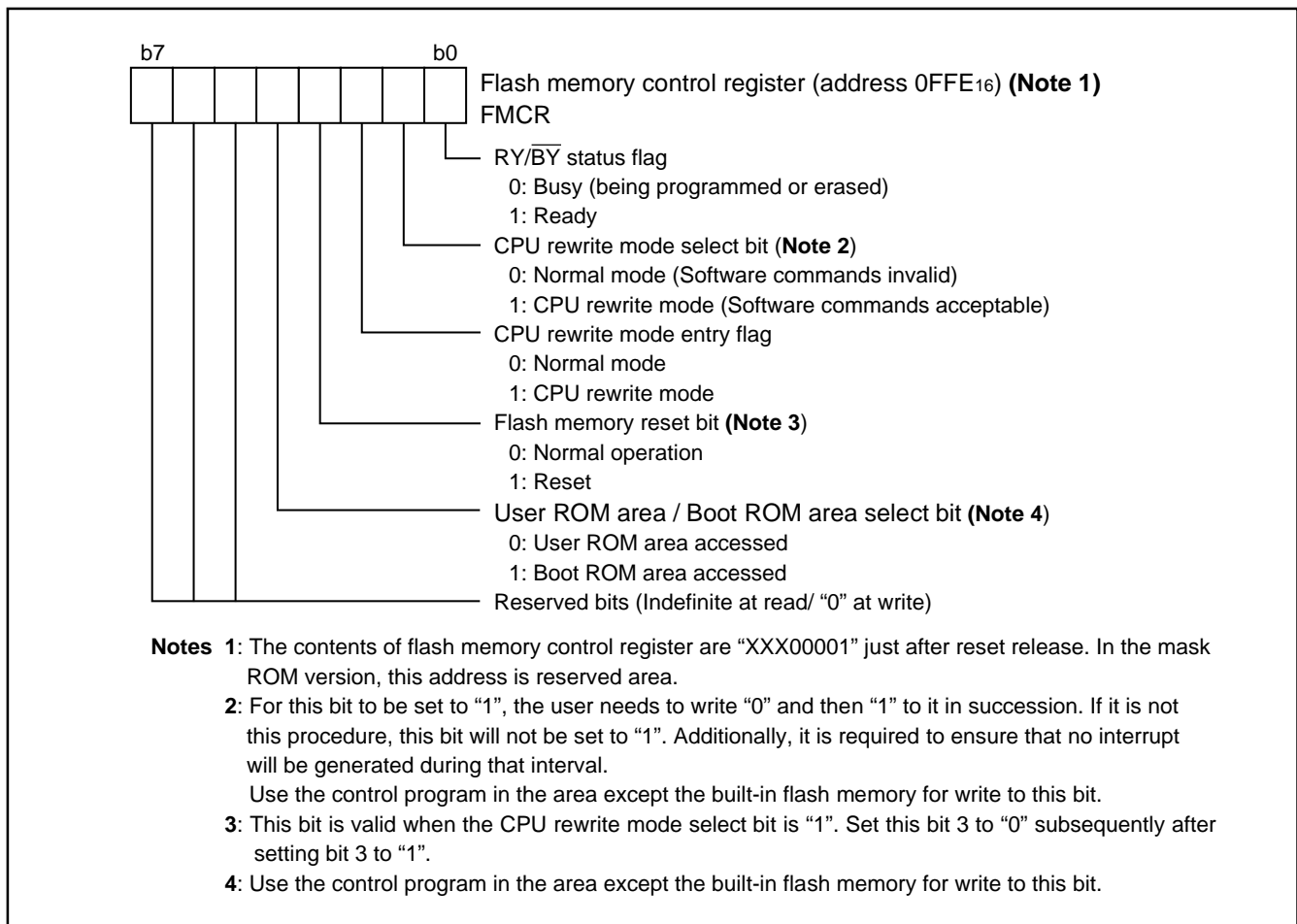

Fig.48 Structure of flash memory control register

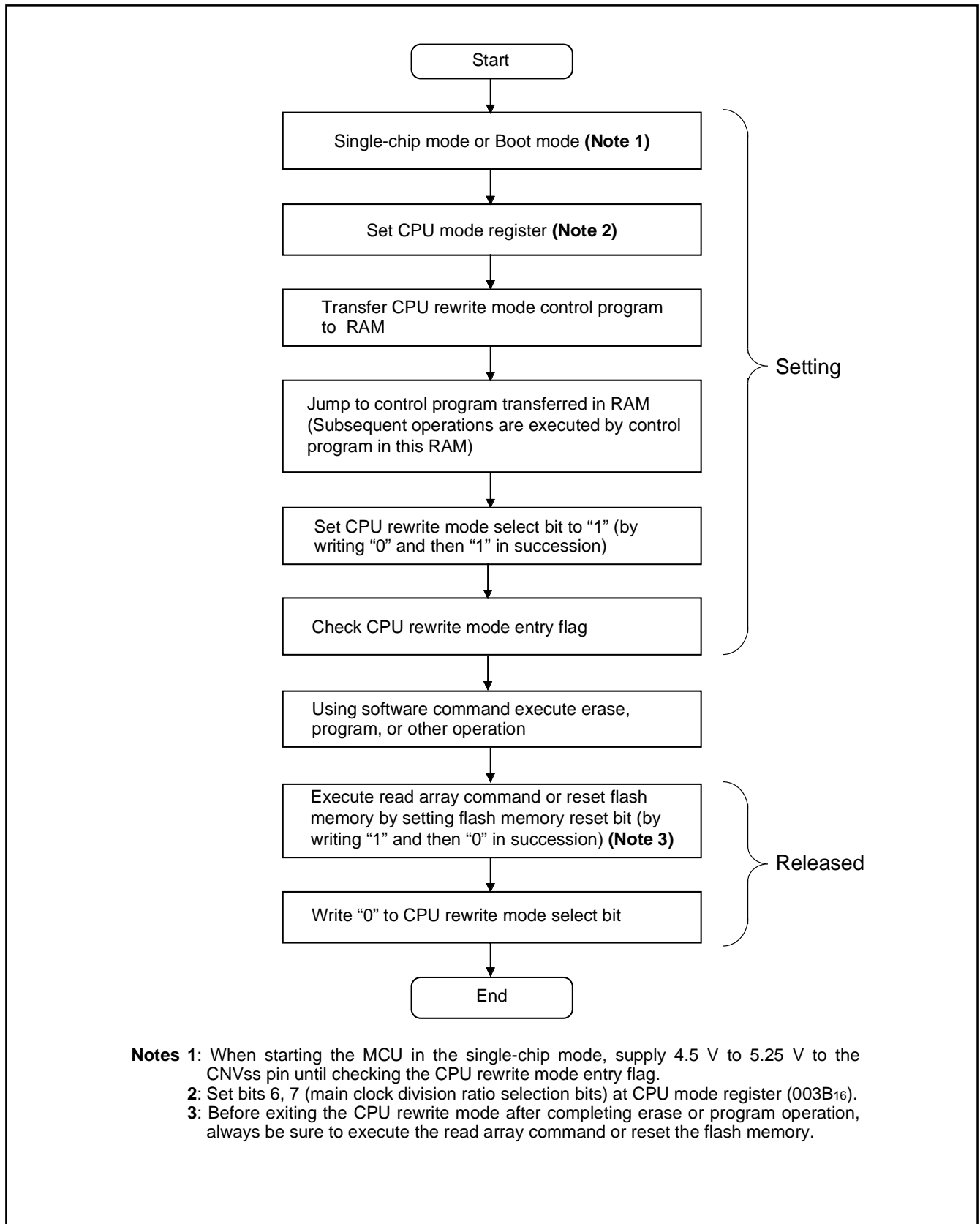

Fig. 49 CPU rewrite mode set/release flowchart

## Precautions on CPU Rewrite Mode

Described below are the precautions to be observed when rewriting the flash memory in CPU rewrite mode.

### (1) Operation speed

During CPU rewrite mode, set the internal clock frequency 6.25 MHz or less using the main clock division ratio selection bits (bit 6, 7 at 003B<sub>16</sub>).

### (2) Instructions inhibited against use

The instructions which refer to the internal data of the flash memory cannot be used during CPU rewrite mode .

### (3) Interrupts inhibited against use

The interrupts cannot be used during CPU rewrite mode because they refer to the internal data of the flash memory.

### (4) Watchdog timer

In case of the watchdog timer has been running already, the internal reset generated by watchdog timer underflow does not happen, because of watchdog timer is always clearing during program or erase operation.

### (5) Reset

Reset is always valid. In case of CNVss = H when reset is released, boot mode is active. So the program starts from the address contained in address FFFC<sub>16</sub> and FFFD<sub>16</sub> in boot ROM area.

### Software Commands (CPU Rewrite Mode)

Table 9 lists the software commands.

After setting the CPU Rewrite Mode Select Bit of the flash memory control register to “1”, execute a software command to specify an erase or program operation.

Each software command is explained below.

#### ●Read Array Command (FF16)

The read array mode is entered by writing the command code “FF16” in the first bus cycle. When an address to be read is input in one of the bus cycles that follow, the contents of the specified address are read out at the data bus (D0 to D7).

The read array mode is retained intact until another command is written.

#### ●Read Status Register Command (7016)

The read status register mode is entered by writing the command code “7016” in the first bus cycle. The contents of the status register are read out at the data bus (D0 to D7) by a read in the second bus cycle.

The status register is explained in the next section.

#### ●Clear Status Register Command (5016)

This command is used to clear the bits SR1, SR4, and SR5 of the status register after they have been set. These bits indicate that operation has ended in an error. To use this command, write the command code “5016” in the first bus cycle.

#### ●Program Command (4016)

Program operation starts when the command code “4016” is written in the first bus cycle. Then, if the address and data to program are written in the 2nd bus cycle, program operation (data programming and verification) will start.

Whether the write operation is completed can be confirmed by reading the status register or the RY/BY Status Flag of the flash memory control register. When the program starts, the read status

register mode is entered automatically and the contents of the status register is read at the data bus (D0 to D7). The status register bit 7 (SR7) is set to “0” at the same time the write operation starts and is returned to “1” upon completion of the write operation. In this case, the read status register mode remains active until the next command is written.

The RY/BY Status Flag is “0” (busy) during write operation and “1” (ready) when the write operation is completed as is the status register bit 7.

At program end, program results can be checked by reading bit 4 (SR4) of the status register.

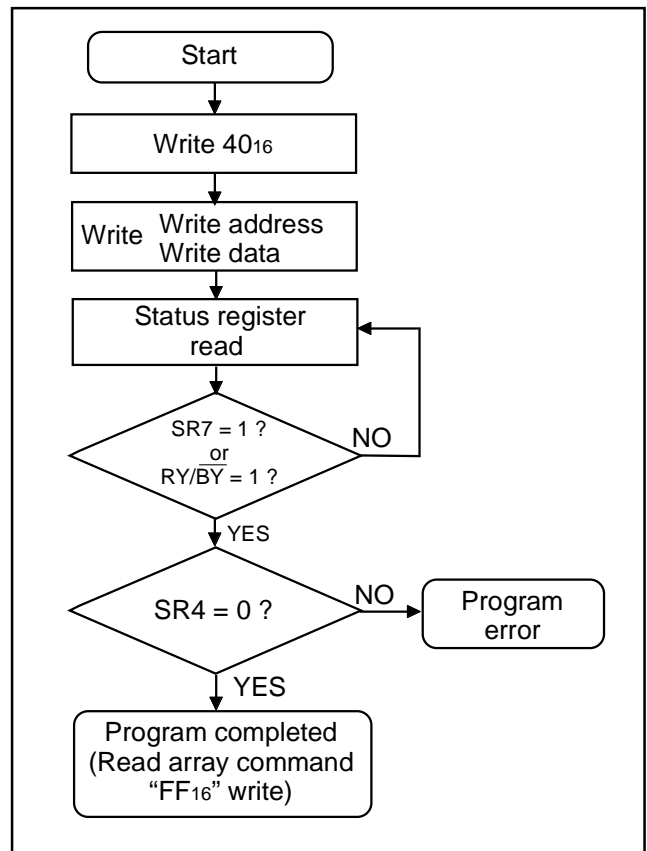

Fig. 50 Program flowchart

Table 9 List of software commands (CPU rewrite mode)

Command	Cycle number	First bus cycle			Second bus cycle		
		Mode	Address	Data (D0 to D7)	Mode	Address	Data (D0 to D7)
Read array	1	Write	X (Note 1)	FF16			
Read status register	2	Write	X	7016	Read	X	SRD (Note 2)
Clear status register	1	Write	X	5016			
Program	2	Write	X	4016	Write	WA (Note 3)	WD (Note 3)
Erase all blocks	2	Write	X	2016	Write	X	2016
Block erase	2	Write	X	2016	Write	BA (Note 4)	D016

Notes 1: X denotes a given address in the User ROM area .

2: SRD = Status Register Data

3: WA = Write Address, WD = Write Data

4: BA = Block Address to be erased (Input the maximum address of each block.)

### ●Erase All Blocks Command (20<sub>16</sub>/20<sub>16</sub>)

By writing the command code "20<sub>16</sub>" in the first bus cycle and the confirmation command code "20<sub>16</sub>" in the second bus cycle that follows, the operation of erase all blocks (erase and erase verify) starts.

Whether the erase all blocks command is terminated can be confirmed by reading the status register or the RY/ $\overline{\text{BY}}$  Status Flag of flash memory control register. When the erase all blocks operation starts, the read status register mode is entered automatically and the contents of the status register can be read out at the data bus (D<sub>0</sub> to D<sub>7</sub>). The status register bit 7 (SR7) is set to "0" at the same time the erase operation starts and is returned to "1" upon completion of the erase operation. In this case, the read status register mode remains active until another command is written.

The RY/ $\overline{\text{BY}}$  Status Flag is "0" during erase operation and "1" when the erase operation is completed as is the status register bit 7 (SR7).

After the erase all blocks end, erase results can be checked by reading bit 5 (SRS) of the status register. For details, refer to the section where the status register is detailed.

### ●Block Erase Command (20<sub>16</sub>/D0<sub>16</sub>)

By writing the command code "20<sub>16</sub>" in the first bus cycle and the confirmation command code "D0<sub>16</sub>" and the block address in the second bus cycle that follows, the block erase (erase and erase verify) operation starts for the block address of the flash memory to be specified.

Whether the block erase operation is completed can be confirmed by reading the status register or the RY/ $\overline{\text{BY}}$  Status Flag of flash memory control register. At the same time the block erase operation starts, the read status register mode is automatically entered, so that the contents of the status register can be read out. The status register bit 7 (SR7) is set to "0" at the same time the block erase operation starts and is returned to "1" upon completion of the block erase operation. In this case, the read status register mode remains active until the read array command (FF<sub>16</sub>) is written.

The RY/ $\overline{\text{BY}}$  Status Flag is "0" during block erase operation and "1" when the block erase operation is completed as is the status register bit 7.

After the block erase ends, erase results can be checked by reading bit 5 (SRS) of the status register. For details, refer to the section where the status register is detailed.

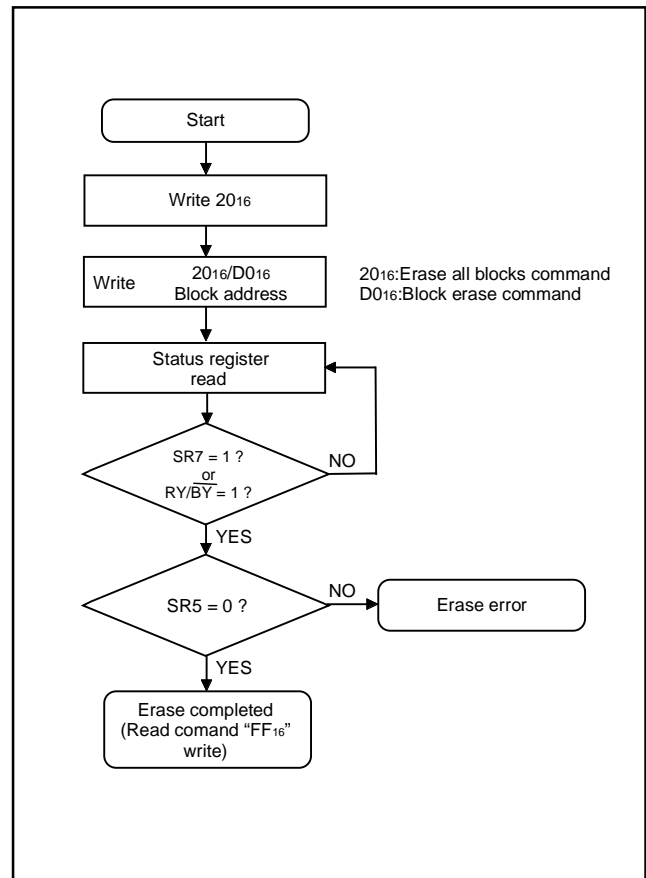

Fig. 51 Erase flowchart

## Status Register (SRD)

The status register shows the operating status of the flash memory and whether erase operations and programs ended successfully or in error. It can be read in the following ways:

- (1) By reading an arbitrary address from the User ROM area after writing the read status register command (70<sub>16</sub>)
- (2) By reading an arbitrary address from the User ROM area in the period from when the program starts or erase operation starts to when the read array command (FF<sub>16</sub>) is input.

Also, the status register can be cleared by writing the clear status register command (50<sub>16</sub>).

After reset, the status register is set to "80<sub>16</sub>".

Table 10 shows the status register. Each bit in this register is explained below.

### •Sequencer status (SR7)

The sequencer status indicates the operating status of the flash memory. This bit is set to "0" (busy) during write or erase operation and is set to "1" when these operations ends.

After power-on, the sequencer status is set to "1" (ready).

### •Erase status (SR5)

The erase status indicates the operating status of erase operation. If an erase error occurs, it is set to "1". When the erase status is cleared, it is set to "0".

### •Program status (SR4)

The program status indicates the operating status of write operation. When a write error occurs, it is set to "1".

The program status is set to "0" when it is cleared.

If "1" is written for any of the SR5 and SR4 bits, the program, erase all blocks, and block erase commands are not accepted.

Before executing these commands, execute the clear status register command (50<sub>16</sub>) and clear the status register.

Also, if any commands are not correct, both SR5 and SR4 are set to "1".

**Table 10 Definition of each bit in status register (SRD)**

Symbol	Status name	Definition	
		"1"	"0"
SR7 (bit7)	Sequencer status	Ready	Busy
SR6 (bit6)	Reserved	-	-
SR5 (bit5)	Erase status	Terminated in error	Terminated normally
SR4 (bit4)	Program status	Terminated in error	Terminated normally
SR3 (bit3)	Reserved	-	-
SR2 (bit2)	Reserved	-	-
SR1 (bit1)	Reserved	-	-
SR0 (bit0)	Reserved	-	-



## Full Status Check

By performing full status check, it is possible to know the execution results of erase and program operations. Figure 52 shows a

full status check flowchart and the action to be taken when each error occurs.

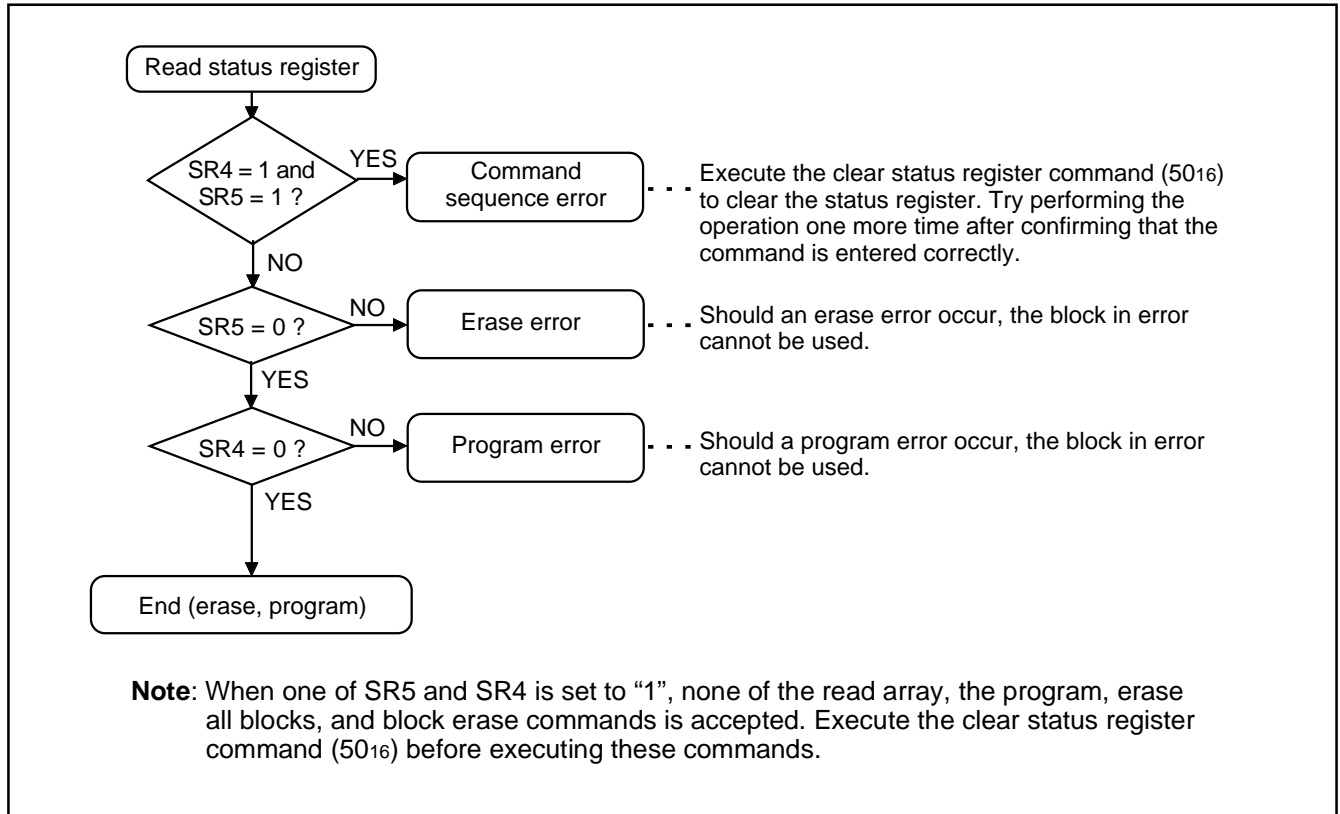

Fig. 52 Full status check flowchart and remedial procedure for errors

## Functions To Inhibit Rewriting Flash Memory Version

To prevent the contents of internal flash memory from being read out or rewritten easily, this MCU incorporates a ROM code protect function for use in parallel I/O mode and an ID code check function for use in standard serial I/O mode.

### ●ROM Code Protect Function (in Parallel I/O Mode)

The ROM code protect function is the function to inhibit reading out or modifying the contents of internal flash memory by using the ROM code protect control (address FFDB16) in parallel I/O mode. Figure 53 shows the ROM code protect control (address FFDB16). (This address exists in the User ROM area.)

If one or both of the pair of ROM Code Protect Bits is set to "0",

the ROM code protect is turned on, so that the contents of internal flash memory are protected against readout and modification. The ROM code protect is implemented in two levels. If level 2 is selected, the flash memory is protected even against readout by a shipment inspection LSI tester, etc. When an attempt is made to select both level 1 and level 2, level 2 is selected by default.

If both of the two ROM Code Protect Reset Bits are set to "00", the ROM code protect is turned off, so that the contents of internal flash memory can be read out or modified. Once the ROM code protect is turned on, the contents of the ROM Code Protect Reset Bits cannot be modified in parallel I/O mode. Use the serial I/O or CPU rewrite mode to rewrite the contents of the ROM Code Protect Reset Bits.

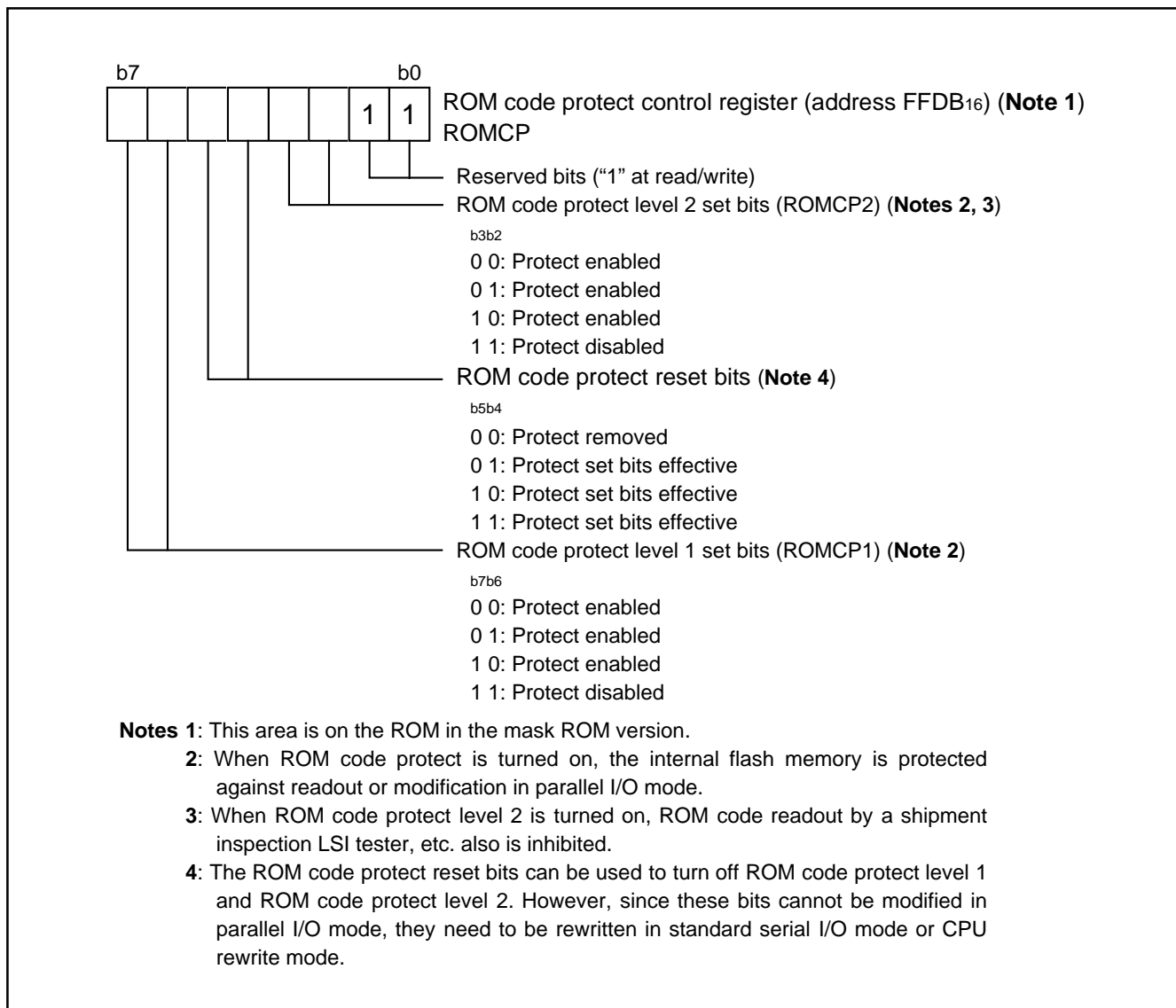

Fig. 53 Structure of ROM code protect control

### ID Code Check Function (in Standard serial I/O mode)

Use this function in standard serial I/O mode. When the contents of the flash memory are not blank, the ID code sent from the programmer is compared with the ID code written in the flash memory to see if they match. If the ID codes do not match, the commands sent from the programmer are not accepted. The ID code consists of 8-bit data, and its areas are FFDA<sub>16</sub> to FFDA<sub>16</sub>. Write a program which has had the ID code preset at these addresses to the flash memory.

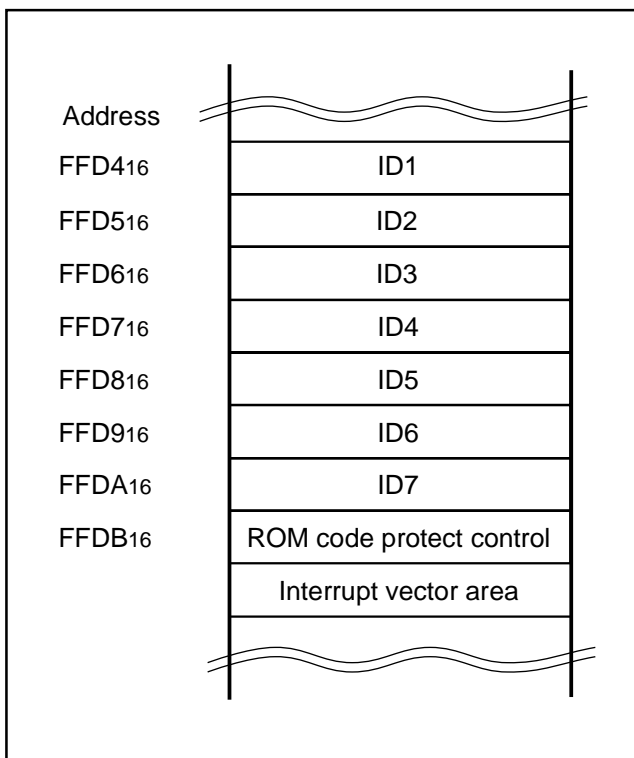

Fig. 54 ID code store addresses

## (2) Parallel I/O Mode

Parallel I/O mode is the mode which parallel output and input software command, address, and data required for the operations (read, program, erase, etc.) to a built-in flash memory. Use the exclusive external equipment flash programmer which supports the 3850 Group (flash memory version). Refer to each programmer maker's handling manual for the details of the usage.

### User ROM and Boot ROM Areas

In parallel I/O mode, the user ROM and boot ROM areas shown in Figure 47 can be rewritten. Both areas of flash memory can be operated on in the same way.

Program and block erase operations can be performed in the user ROM area. The user ROM area and its block is shown in Figure 47.

The boot ROM area is 4 Kbytes in size. It is located at addresses F000<sub>16</sub> through FFFF<sub>16</sub>. Make sure program and block erase operations are always performed within this address range. (Access to any location outside this address range is prohibited.)

In the Boot ROM area, an erase block operation is applied to only one 4 Kbyte block. The boot ROM area has had a standard serial I/O mode control program stored in it when shipped from the Mitsubishi factory. Therefore, using the device in standard serial I/O mode, you do not need to write to the boot ROM area.

### (3) Standard serial I/O Mode

The standard serial I/O mode inputs and outputs the software commands, addresses and data needed to operate (read, program, erase, etc.) the internal flash memory. This I/O is clock synchronized serial. This mode requires the exclusive external equipment (serial programmer).

The standard serial I/O mode is different from the parallel I/O mode in that the CPU controls flash memory rewrite (uses the CPU rewrite mode), rewrite data input and so forth. The standard serial I/O mode is started by connecting "H" to the P26 (SCLK1) pin and "H" to the P41 (INT0) pin and "H" to the CNVSS pin (apply 4.5 V to 5.5 V to Vpp from an external source), and releasing the reset operation. (In the ordinary microcomputer mode, set CNVSS pin to "L" level.)

This control program is written in the Boot ROM area when the product is shipped from Mitsubishi. Accordingly, make note of the fact that the standard serial I/O mode cannot be used if the Boot ROM area is rewritten in parallel I/O mode. Figure 55 shows the pin connection for the standard serial I/O mode.

In standard serial I/O mode, serial data I/O uses the four serial I/O pins SCLK1, RxD, TxD and  $\overline{\text{SRDY1}}$  (BUSY). The SCLK1 pin is the transfer clock input pin through which an external transfer clock is input. The TxD pin is for CMOS output. The  $\overline{\text{SRDY1}}$  (BUSY) pin outputs "L" level when ready for reception and "H" level when reception starts.

Serial data I/O is transferred serially in 8-bit units.

In standard serial I/O mode, only the User ROM area shown in Figure 47 can be rewritten. The Boot ROM area cannot.

In standard serial I/O mode, a 7-byte ID code is used. When there is data in the flash memory, commands sent from the peripheral unit (programmer) are not accepted unless the ID code matches.

### Outline Performance (Standard Serial I/O Mode)

In standard serial I/O mode, software commands, addresses and data are input and output between the MCU and peripheral units (serial programmer, etc.) using 4-wire clock-synchronized serial I/O (serial I/O1).

In reception, software commands, addresses and program data are synchronized with the rise of the transfer clock that is input to the SCLK1 pin, and are then input to the MCU via the RxD pin. In transmission, the read data and status are synchronized with the fall of the transfer clock, and output from the TxD pin.

The TxD pin is for CMOS output. Transfer is in 8-bit units with LSB first.

When busy, such as during transmission, reception, erasing or program execution, the  $\overline{\text{SRDY1}}$  (BUSY) pin is "H" level. Accordingly, always start the next transfer after the  $\overline{\text{SRDY1}}$  (BUSY) pin is "L" level.

Also, data and status registers in a memory can be read after inputting software commands. Status, such as the operating state of the flash memory or whether a program or erase operation ended successfully or not, can be checked by reading the status register. Here following explains software commands, status registers, etc.

**Table 11 Description of pin function (Standard Serial I/O Mode)**

Pin	Name	I/O	Description
Vcc,Vss	Power input		Apply program/erase protection voltage to Vcc pin and 0 V to Vss pin.
CNVss	CNVss	I	Connect to Vcc when Vcc = 4.5 V to 5.5 V. Connect to Vpp (=4.5 V to 5.5 V) when Vcc = 2.7 V to 4.5 V.
RESET	Reset input	I	Reset input pin. While reset is "L" level, a 20 cycle or longer clock must be input to XIN pin.
XIN	Clock input	I	Connect a ceramic resonator or crystal oscillator between XIN and XOUT pins. To input an externally generated clock, input it to XIN pin and open XOUT pin.
XOUT	Clock output	O	
AVss	Analog power supply input		Connect AVss to Vss .
VREF	Reference voltage input	I	Enter the reference voltage for AD from this pin.
P00 to P07	Input port P0	I	Input "H" or "L" level signal or open.
P10 to P17	Input port P1	I	Input "H" or "L" level signal or open.
P20 to P23	Input port P2	I	Input "H" or "L" level signal or open.
P24	RxD input	I	Serial data input pin
P25	TxD output	O	Serial data output pin
P26	SCLK1 input	I	Serial clock input pin
P27	BUSY output	O	BUSY signal output pin
P30 to P34	Input port P3	I	Input "H" or "L" level signal or open.
P40, P42 to P44	Input port P4	I	Input "H" or "L" level signal or open.
P41	Input port P4	I	Input "H" level signal, when reset is released.

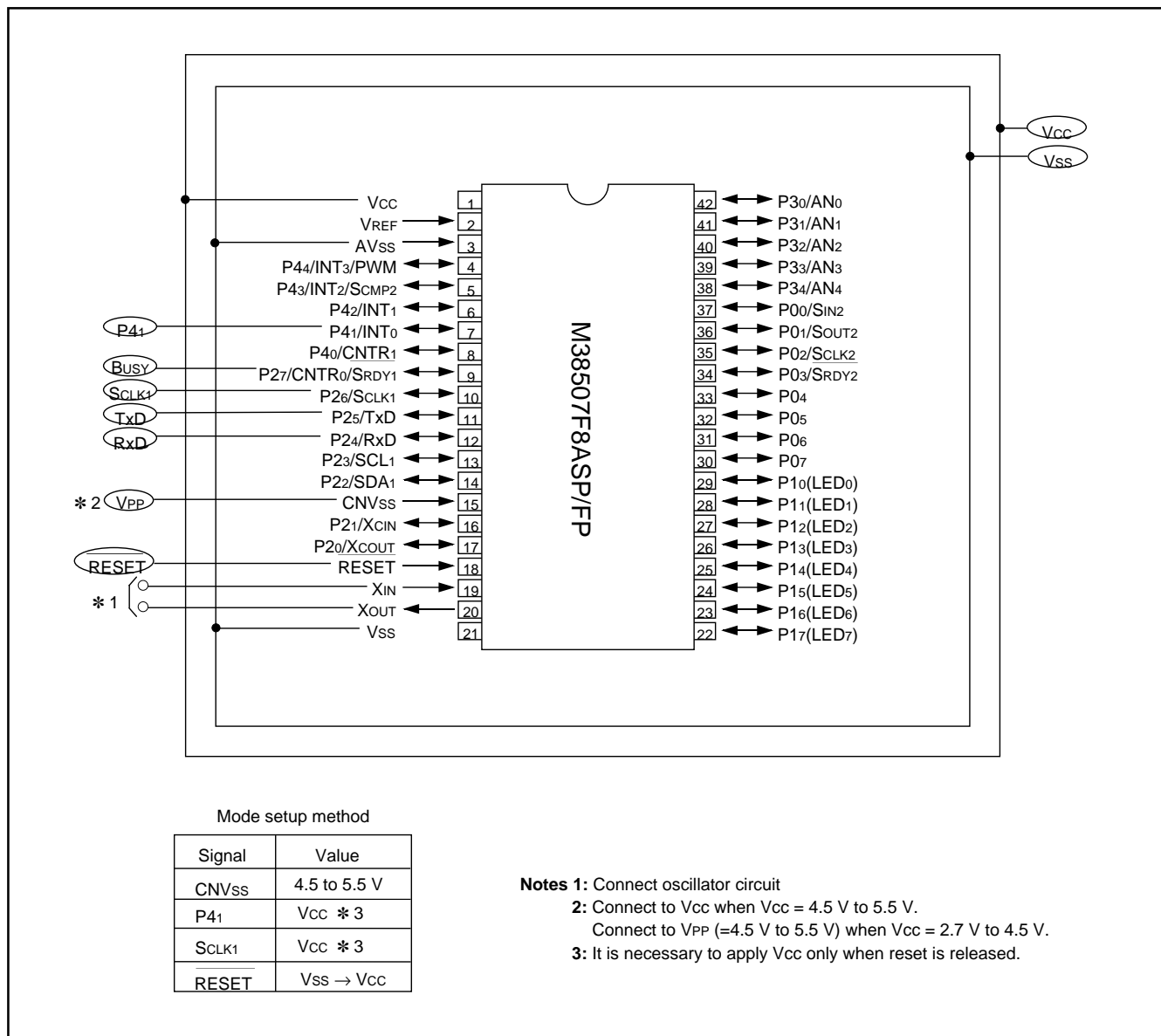

Fig. 55 Pin connection diagram in standard serial I/O mode

## Software Commands (Standard Serial I/O Mode)

Table 12 lists software commands. In standard serial I/O mode, erase, program and read are controlled by transferring software

commands via the RxD pin. Software commands are explained here below.

**Table 12 Software commands (Standard serial I/O mode)**

Control command	1st byte transfer	2nd byte	3rd byte	4th byte	5th byte	6th byte	.....	When ID is not verified
1 Page read	FF <sub>16</sub>	Address (middle)	Address (high)	Data output	Data output	Data output	Data output to 259th byte	Not acceptable
2 Page program	41 <sub>16</sub>	Address (middle)	Address (high)	Data input	Data input	Data input	Data input to 259th byte	Not acceptable
3 Erase all blocks	A7 <sub>16</sub>	D0 <sub>16</sub>						Not acceptable
4 Read status register	70 <sub>16</sub>	SRD output	SRD1 output					Acceptable
5 Clear status register	50 <sub>16</sub>							Not acceptable
6 ID code check	F5 <sub>16</sub>	Address (low)	Address (middle)	Address (high)	ID size	ID1	To ID7	Acceptable
7 Download function	FA <sub>16</sub>	Size (low)	Size (high)	Check-sum	Data input	To required number of times		Not acceptable
8 Version data output function	FB <sub>16</sub>	Version data output	Version data output	Version data output	Version data output	Version data output	Version data output to 9th byte	Acceptable

**Notes1:** Shading indicates transfer from the internal flash memory microcomputer to a programmer. All other data is transferred from an external equipment (programmer) to the internal flash memory microcomputer.

**2:** SRD refers to status register data. SRD1 refers to status register 1 data.

**3:** All commands can be accepted when the flash memory is totally blank.

**4:** Address high must be "00<sub>16</sub>".



**●Page Read Command**

This command reads the specified page (256 bytes) in the flash memory sequentially one byte at a time. Execute the page read command as explained here following.

- (1) Transfer the "FF16" command code with the 1st byte.
- (2) Transfer addresses A8 to A15 and A16 to A23 with the 2nd and 3rd bytes respectively.
- (3) From the 4th byte onward, data (D0 to D7) for the page (256 bytes) specified with addresses A8 to A23 will be output sequentially from the smallest address first synchronized with the fall of the clock.

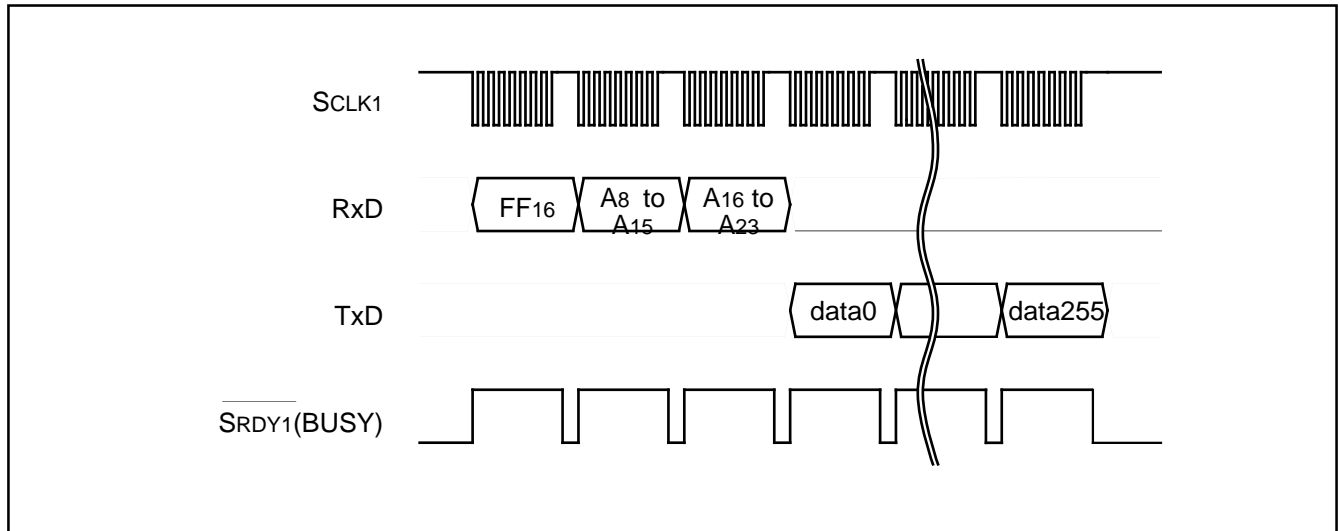

Fig. 56 Timing for page read

**●Read Status Register Command**

This command reads status information. When the "7016" command code is transferred with the 1st byte, the contents of the status register (SRD) with the 2nd byte and the contents of status register 1 (SRD1) with the 3rd byte are read.

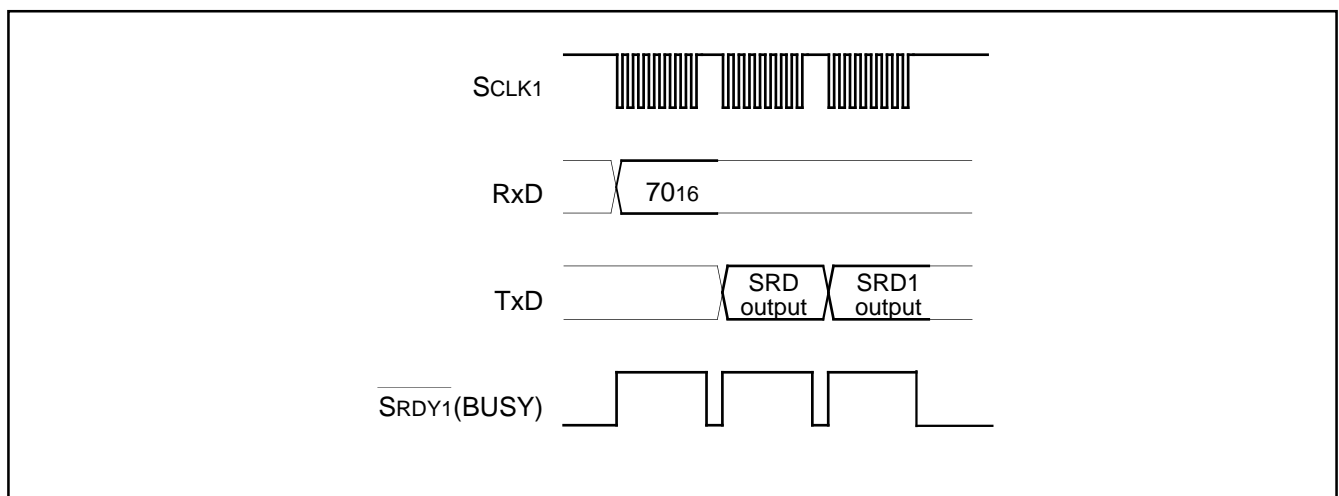

Fig. 57 Timing for reading status register

**●Clear Status Register Command**

This command clears the bits (SR4, SR5) which are set when the status register operation ends in error. When the "5016" command code is sent with the 1st byte, the aforementioned bits are cleared. When the clear status register operation ends, the  $\overline{\text{SRDY1}}$  (BUSY) signal changes from "H" to "L" level.

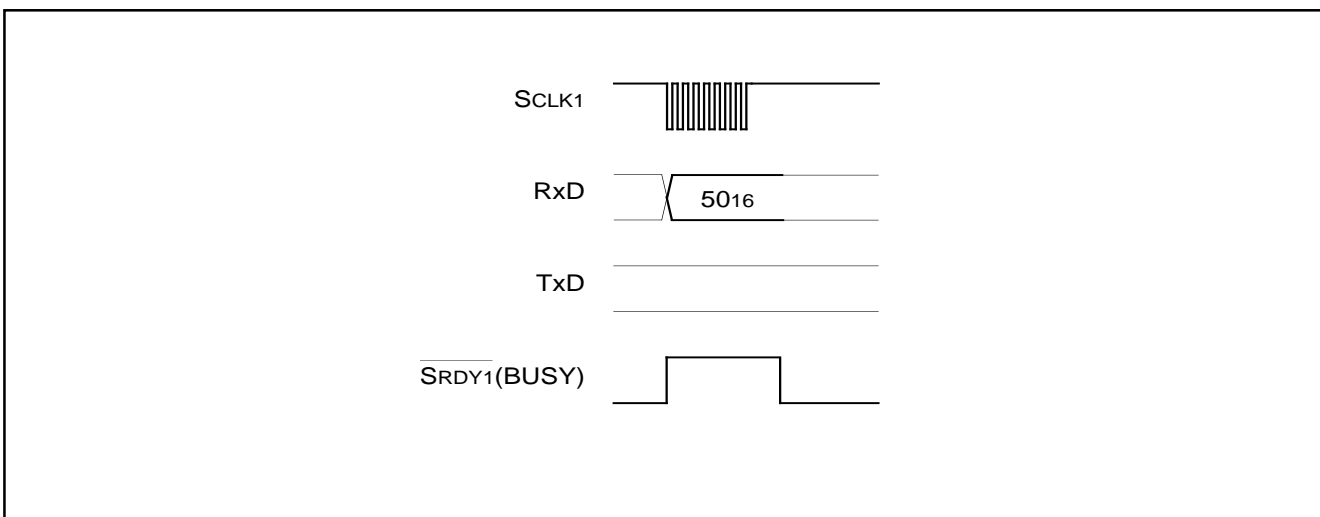

Fig. 58 Timing for clear status register

**●Page Program Command**

This command writes the specified page (256 bytes) in the flash memory sequentially one byte at a time. Execute the page program command as explained here following.

- (1) Transfer the "4116" command code with the 1st byte.
- (2) Transfer addresses A8 to A15 and A16 to A23 ("0016") with the 2nd and 3rd bytes respectively.

- (3) From the 4th byte onward, as write data (D0 to D7) for the page (256 bytes) specified with addresses A8 to A23 is input sequentially from the smallest address first, that page is automatically written.

When reception setup for the next 256 bytes ends, the  $\overline{\text{SRDY1}}$  (BUSY) signal changes from "H" to "L" level. The result of the page program can be known by reading the status register. For more information, see the section on the status register.

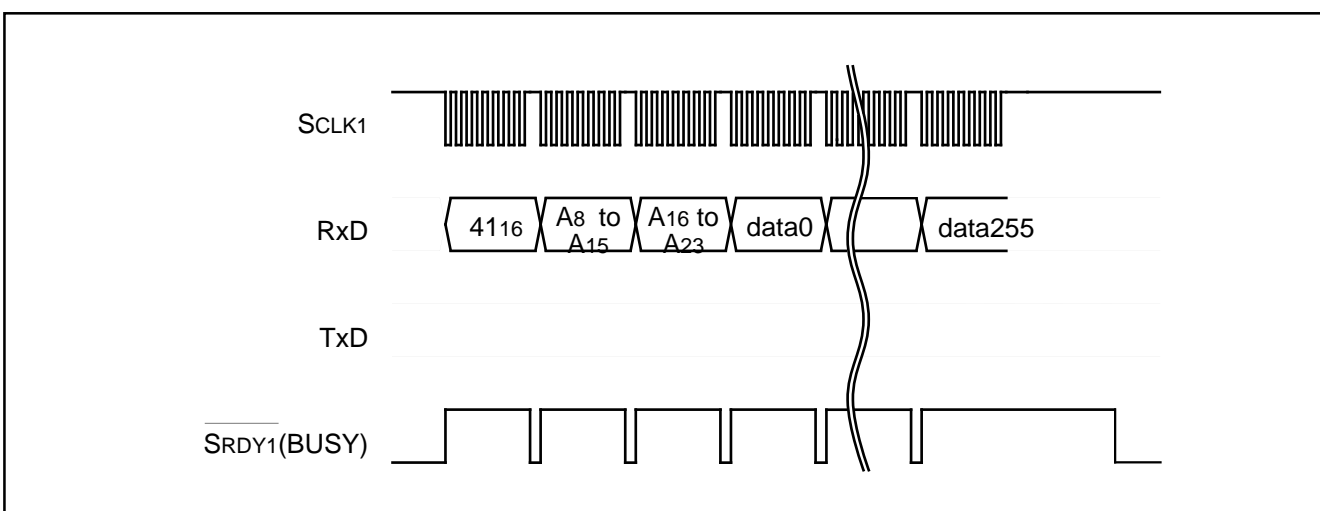

Fig. 59 Timing for page program

**●Erase All Blocks Command**

This command erases the contents of all blocks. Execute the erase all blocks command as explained here following.

- (1) Transfer the "A7<sub>16</sub>" command code with the 1st byte.
- (2) Transfer the verify command code "D0<sub>16</sub>" with the 2nd byte.  
With the verify command code, the erase operation will start and continue for all blocks in the flash memory.

When erase all blocks end, the  $\overline{\text{SRDY1}}$  (BUSY) signal changes from "H" to "L" level. The result of the erase operation can be known by reading the status register.

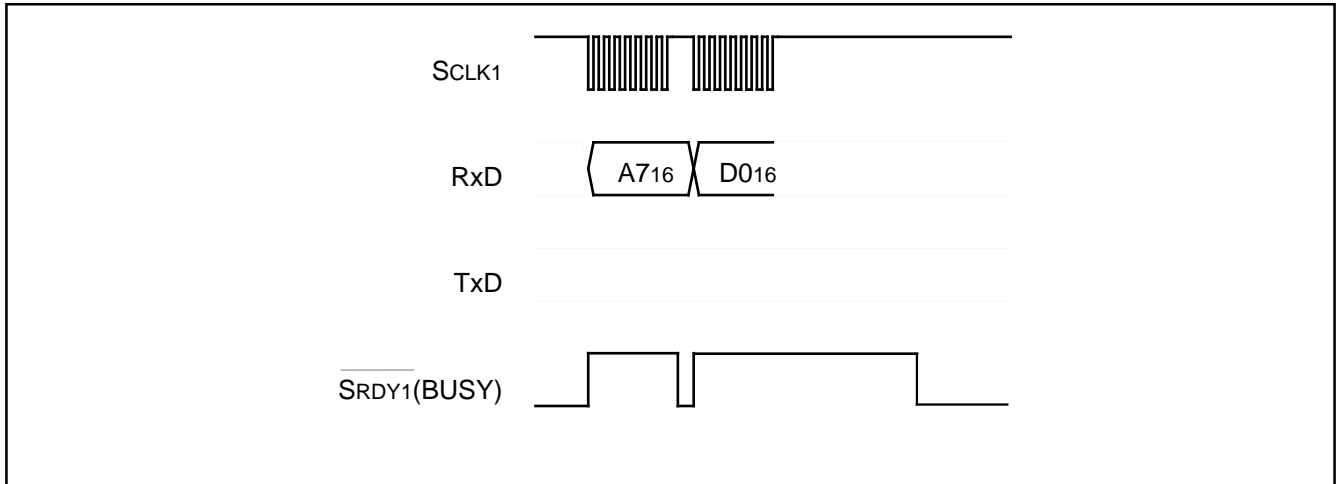

Fig. 60 Timing for erase all blocks

**●Download Command**

This command downloads a program to the RAM for execution. Execute the download command as explained here following.

- (1) Transfer the "FA16" command code with the 1st byte.
- (2) Transfer the program size with the 2nd and 3rd bytes.
- (3) Transfer the check sum with the 4th byte. The check sum is added to all data sent with the 5th byte onward.
- (4) The program to execute is sent with the 5th byte onward.

When all data has been transmitted, if the check sum matches, the downloaded program is executed. The size of the program will vary according to the internal RAM.

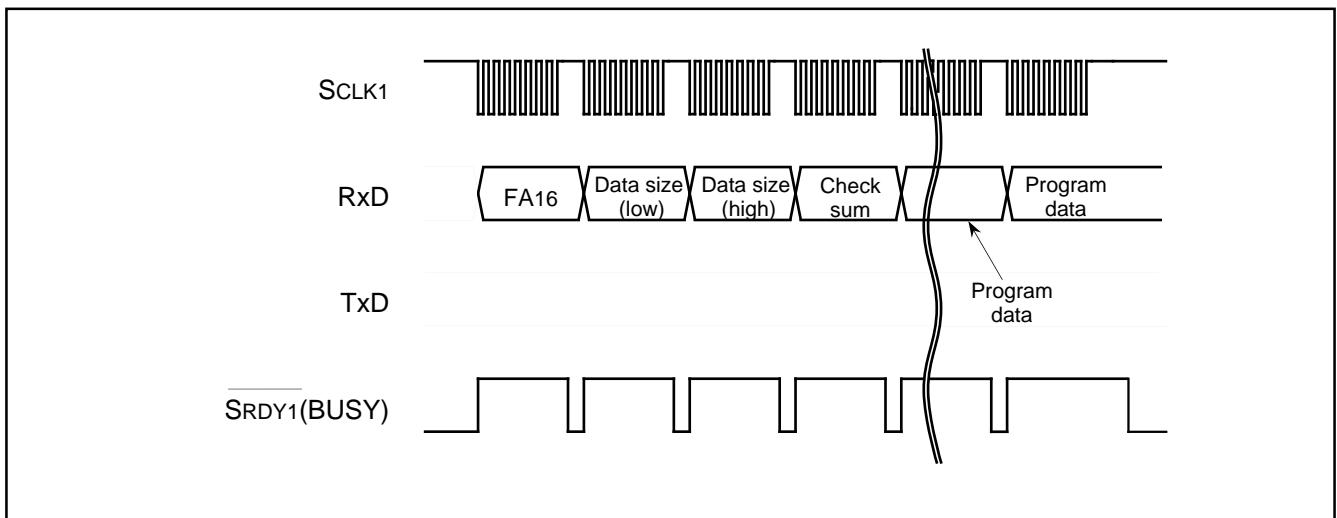

Fig. 61 Timing for download

**●Version Information Output Command**

This command outputs the version information of the control program stored in the Boot ROM area. Execute the version information output command as explained here following.

- (1) Transfer the "FB16" command code with the 1st byte.
  - (2) The version information will be output from the 2nd byte onward.
- This data is composed of 8 ASCII code characters.

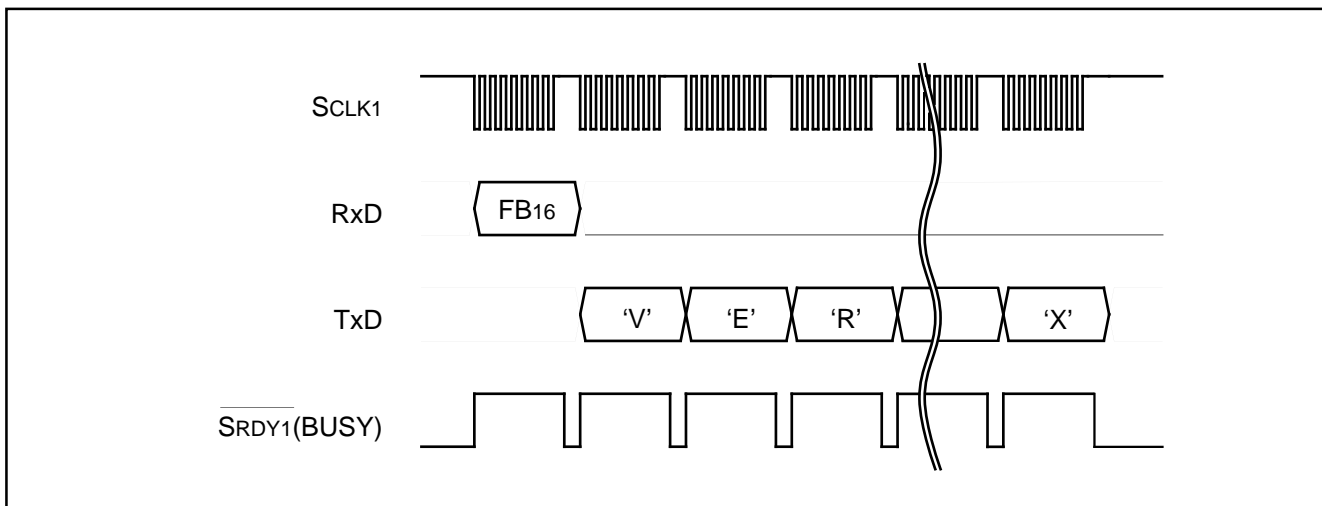

Fig. 62 Timing for version information output

**●ID Check**

This command checks the ID code. Execute the boot ID check command as explained here following.

- (1) Transfer the "F5<sub>16</sub>" command code with the 1st byte.
- (2) Transfer addresses A0 to A7, A8 to A15 and A16 to A23 ("00<sub>16</sub>") of the 1st byte of the ID code with the 2nd, 3rd, and 4th bytes respectively.
- (3) Transfer the number of data sets of the ID code with the 5th byte.
- (4) Transfer the ID code with the 6th byte onward, starting with the 1st byte of the code.

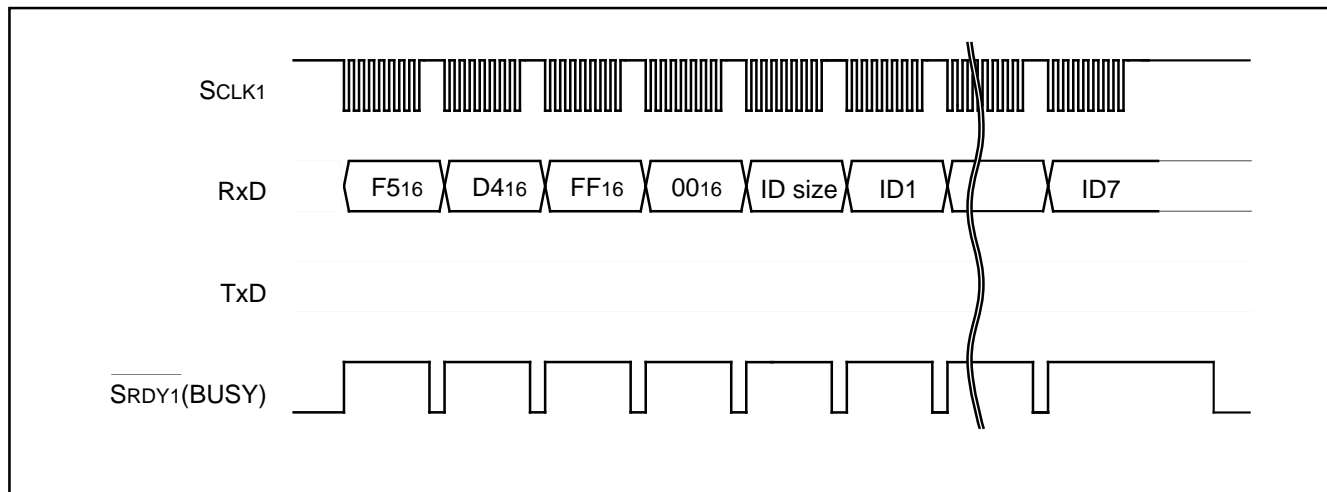

Fig. 63 Timing for ID check

**●ID Code**

When the flash memory is not blank, the ID code sent from the serial programmer and the ID code written in the flash memory are compared to see if they match. If the codes do not match, the command sent from the serial programmer is not accepted. An ID code contains 8 bits of data. Area is, from the 1st byte, addresses FFD4<sub>16</sub> to FFDA<sub>16</sub>. Write a program into the flash memory, which already has the ID code set for these addresses.

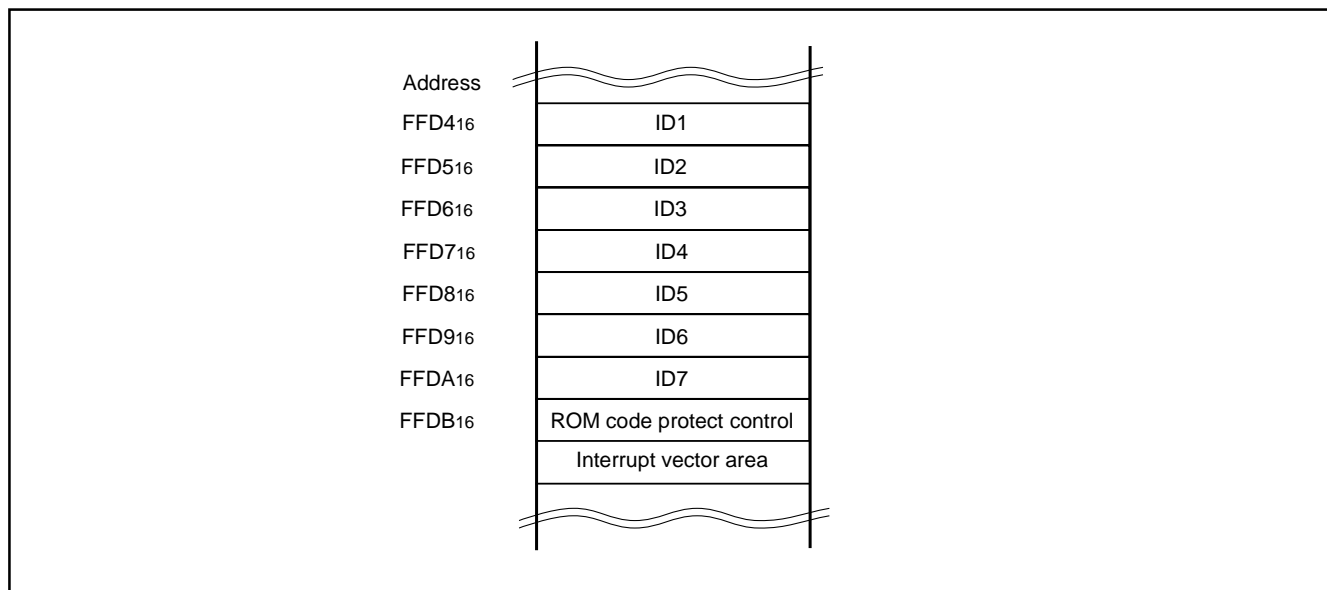

Fig. 64 ID code storage addresses

### ●Status Register (SRD)

The status register indicates operating status of the flash memory and status such as whether an erase operation or a program ended successfully or in error. It can be read by writing the read status register command (70<sub>16</sub>). Also, the status register is cleared by writing the clear status register command (50<sub>16</sub>).

Table 13 lists the definition of each status register bit. After releasing the reset, the status register becomes "80<sub>16</sub>".

### •Sequencer status (SR7)

The sequencer status indicates the operating status of the flash memory.

After power-on and recover from deep power down mode, the sequencer status is set to "1" (ready).

This status bit is set to "0" (busy) during write or erase operation and is set to "1" upon completion of these operations.

### •Erase status (SR5)

The erase status indicates the operating status of erase operation. If an erase error occurs, it is set to "1". When the erase status is cleared, it is set to "0".

### •Program status (SR4)

The program status indicates the operating status of write operation. If a program error occurs, it is set to "1". When the program status is cleared, it is set to "0".

**Table 13 Definition of each bit of status register (SRD)**

SRD0 bits	Status name	Definition	
		"1"	"0"
SR7 (bit7)	Sequencer status	Ready	Busy
SR6 (bit6)	Reserved	-	-
SR5 (bit5)	Erase status	Terminated in error	Terminated normally
SR4 (bit4)	Program status	Terminated in error	Terminated normally
SR3 (bit3)	Reserved	-	-
SR2 (bit2)	Reserved	-	-
SR1 (bit1)	Reserved	-	-
SR0 (bit0)	Reserved	-	-

### ●Status Register 1 (SRD1)

The status register 1 indicates the status of serial communications, results from ID checks and results from check sum comparisons. It can be read after the status register (SRD) by writing the read status register command (70<sub>16</sub>). Also, status register 1 is cleared by writing the clear status register command (50<sub>16</sub>). Table 14 lists the definition of each status register 1 bit. This register becomes "00<sub>16</sub>" when power is turned on and the flag status is maintained even after the reset.

### •Boot update completed bit (SR15)

This flag indicates whether the control program was downloaded to the RAM or not, using the download function.

### •Check sum consistency bit (SR12)

This flag indicates whether the check sum matches or not when a program, is downloaded for execution using the download function.

### •ID check completed bits (SR11 and SR10)

These flags indicate the result of ID checks. Some commands cannot be accepted without an ID code check.

### •Data reception time out (SR9)

This flag indicates when a time out error is generated during data reception. If this flag is attached during data reception, the received data is discarded and the MCU returns to the command wait state.

**Table 14 Definition of each bit of status register 1 (SRD1)**

SRD1 bits	Status name	Definition	
		"1"	"0"
SR15 (bit7)	Boot update completed bit	Update completed	Not Update
SR14 (bit6)	Reserved	-	-
SR13 (bit5)	Reserved	-	-
SR12 (bit4)	Checksum match bit	Match	Mismatch
SR11 (bit3) SR10 (bit2)	ID check completed bits	00 01 10 11	Not verified Verification mismatch Reserved Verified
SR9 (bit1)	Data reception time out	Time out	Normal operation
SR8 (bit0)	Reserved	-	-



## Full Status Check

Results from executed erase and program operations can be known by running a full status check. Figure 65 shows a flowchart of the full status check and explains how to remedy errors which occur.

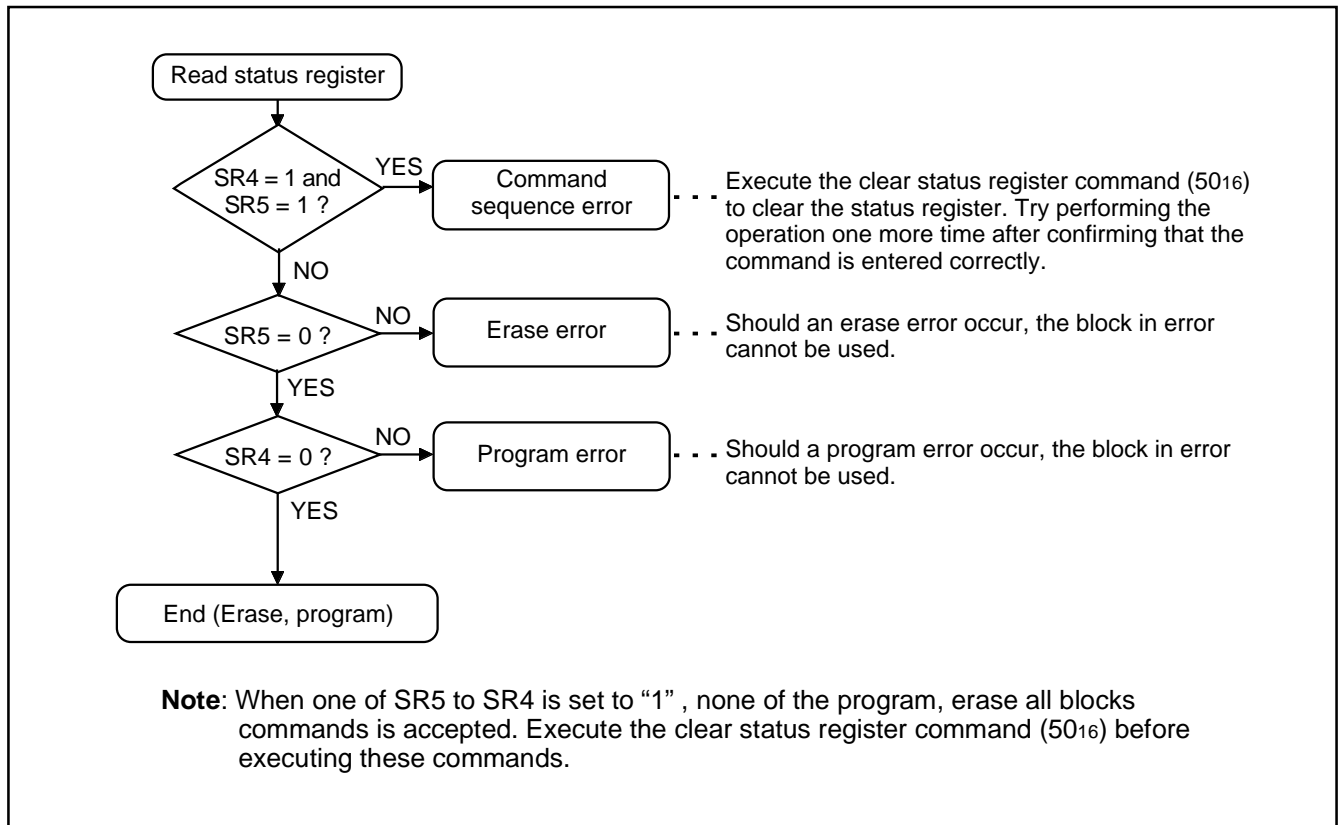

Fig. 65 Full status check flowchart and remedial procedure for errors

## Example Circuit Application for Standard Serial I/O Mode

Figure 66 shows a circuit application for the standard serial I/O mode. Control pins will vary according to a programmer, therefore see a programmer manual for more information.

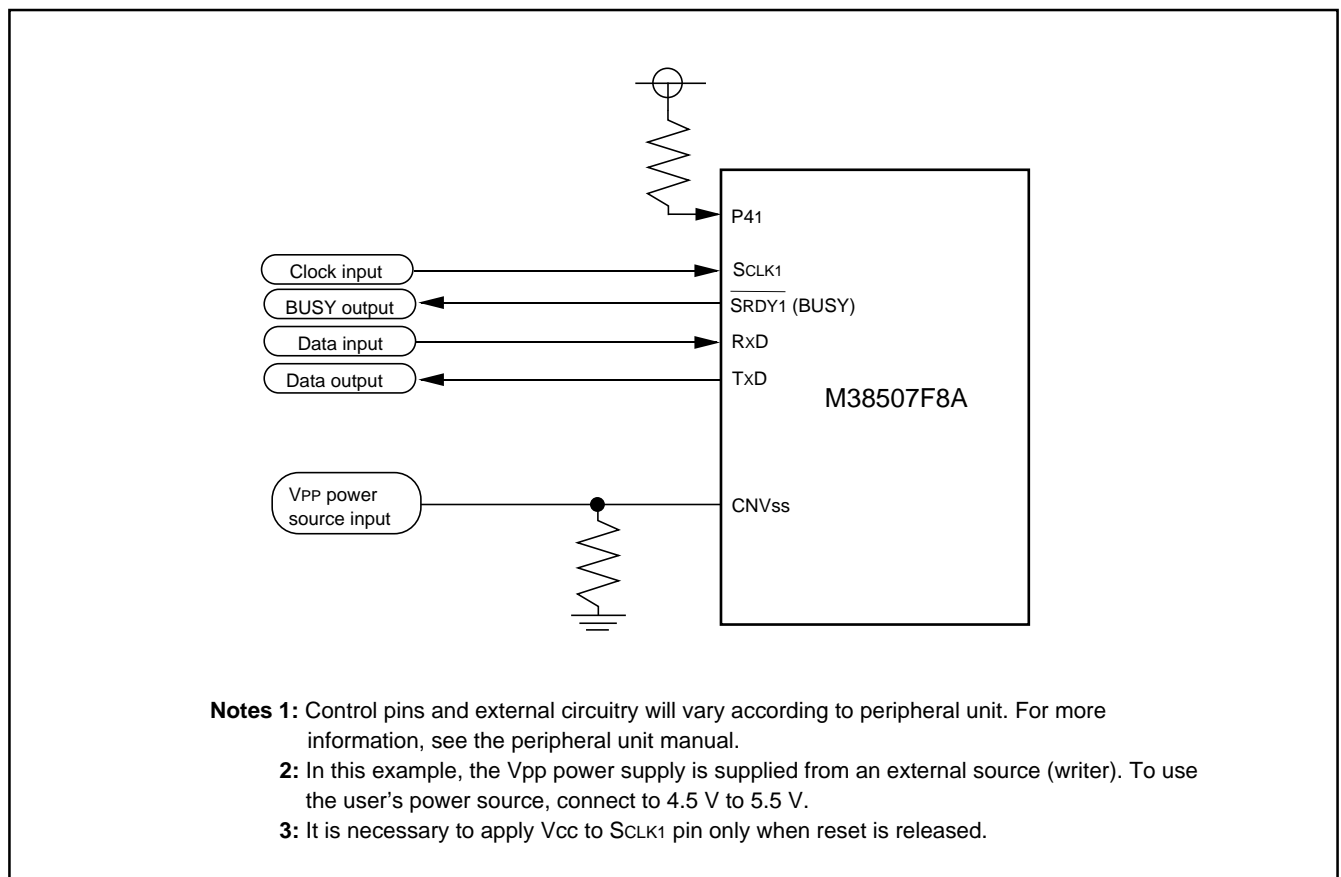

Fig. 66 Example circuit application for standard serial I/O mode

## Flash memory Electrical characteristics

**Table 15 Absolute maximum ratings**

Symbol	Parameter	Conditions	Ratings	Unit
V <sub>CC</sub>	Power source voltage	All voltages are based on V <sub>SS</sub> . When an input voltage is measured, output transistors are cut off.	-0.3 to 6.5	V
V <sub>I</sub>	Input voltage P00–P07, P10–P17, P20, P21, P24–P27, P30–P34, P40–P44, VREF		-0.3 to V <sub>CC</sub> +0.3	V
V <sub>I</sub>	Input voltage P22, P23		-0.3 to 5.8	V
V <sub>I</sub>	Input voltage RESET, XIN		-0.3 to V <sub>CC</sub> +0.3	V
V <sub>I</sub>	Input voltage CNVSS		-0.3 to 6.5	V
V <sub>O</sub>	Output voltage P00–P07, P10–P17, P20, P21, P24–P27, P30–P34, P40–P44, XOUT		-0.3 to V <sub>CC</sub> +0.3	V
V <sub>O</sub>	Output voltage P22, P23		-0.3 to 5.8	V
P <sub>d</sub>	Power dissipation		T <sub>a</sub> = 25 °C	1000 (Note)
T <sub>opr</sub>	Operating temperature		25±5	°C
T <sub>stg</sub>	Storage temperature		-40 to 125	°C

**Note:** The rating becomes 300 mW at the PRSP0042GA-B package.

**Table 16 Flash memory mode Electrical characteristics**  
(T<sub>a</sub> = 25°C, V<sub>CC</sub> = 4.5 to 5.5V unless otherwise noted)

Symbol	Parameter	Conditions	Limits			Unit
			Min.	Typ.	Max.	
I <sub>PP1</sub>	V <sub>PP</sub> power source current (read)	V <sub>PP</sub> = V <sub>CC</sub>			100	μA
I <sub>PP2</sub>	V <sub>PP</sub> power source current (program)	V <sub>PP</sub> = V <sub>CC</sub>			60	mA
I <sub>PP3</sub>	V <sub>PP</sub> power source current (erase)	V <sub>PP</sub> = V <sub>CC</sub>			30	mA
V <sub>PP</sub>	V <sub>PP</sub> power source voltage		4.5		5.5	V
V <sub>CC</sub>	V <sub>CC</sub> power source voltage	Microcomputer mode operation at V <sub>CC</sub> = 2.7 to 5.5V	4.5		5.5	V
		Microcomputer mode operation at V <sub>CC</sub> = 2.7 to 3.6V	3.0		3.6	V

## NOTES ON PROGRAMMING

### Processor Status Register

The contents of the processor status register (PS) after a reset are undefined, except for the interrupt disable flag (I) which is "1". After a reset, initialize flags which affect program execution. In particular, it is essential to initialize the index X mode (T) and the decimal mode (D) flags because of their effect on calculations.

### Interrupts

The contents of the interrupt request bits do not change immediately after they have been written. After writing to an interrupt request register, execute at least one instruction before performing a BBC or BBS instruction.

### Decimal Calculations

- To calculate in decimal notation, set the decimal mode flag (D) to "1", then execute an ADC or SBC instruction. After executing an ADC or SBC instruction, execute at least one instruction before executing a SEC, CLC, or CLD instruction.
- In decimal mode, the values of the negative (N), overflow (V), and zero (Z) flags are invalid.

### Timers

If a value n (between 0 and 255) is written to a timer latch, the frequency division ratio is  $1/(n+1)$ .

### Multiplication and Division Instructions

- The index X mode (T) and the decimal mode (D) flags do not affect the MUL and DIV instruction.
- The execution of these instructions does not change the contents of the processor status register.

### Ports

The contents of the port direction registers cannot be read. The following cannot be used:

- The data transfer instruction (LDA, etc.)
- The operation instruction when the index X mode flag (T) is "1"
- The addressing mode which uses the value of a direction register as an index
- The bit-test instruction (BBC or BBS, etc.) to a direction register
- The read-modify-write instructions (ROR, CLB, or SEB, etc.) to a direction register.

Use instructions such as LDM and STA, etc., to set the port direction registers.

### Serial Interface

In clock synchronous serial I/O, if the receive side is using an external clock and it is to output the  $\overline{\text{SRDY}}_1$  signal, set the transmit enable bit, the receive enable bit, and the  $\overline{\text{SRDY}}_1$  output enable bit to "1".

Serial I/O1 continues to output the final bit from the TxD pin after transmission is completed.

SOUT2 pin for serial I/O2 goes to high impedance after transmission is completed.

When an external clock is used as synchronous clock in serial I/O1 or serial I/O2, write transmission data to the transmit buffer register or serial I/O2 register while the transfer clock is "H".

### A/D Converter

The comparator uses capacitive coupling amplifier whose charge will be lost if the clock frequency is too low.

Therefore, make sure that  $f(\text{XIN})$  in the middle/high-speed mode is at least on 500 kHz during an A/D conversion.

Do not execute the STP instruction during an A/D conversion.

### Instruction Execution Time

The instruction execution time is obtained by multiplying the frequency of the internal clock  $\phi$  by the number of cycles needed to execute an instruction.

The number of cycles required to execute an instruction is shown in the list of machine instructions.

The frequency of the internal clock  $\phi$  is half of the XIN frequency in high-speed mode.

### Reserved Area, Reserved bit

Do not write any data to the reserved area and the reserved bit. (Do not change the contents after reset.)

### CPU Mode Register

Fix bit 3 of the CPU mode register to "1".

## NOTES ON USAGE

### Differences among 3850 group (standard), 3850 group (spec. H), and 3850 group (spec. A)

- (1) The absolute maximum ratings of 3850 group (spec. H/A) is smaller than that of 3850 group (standard).
  - Power source voltage  $V_{CC} = -0.3$  to  $6.5$  V
  - CNVss input voltage  $V_I = -0.3$  to  $V_{CC} + 0.3$  V
- (2) The oscillation circuit constants of X<sub>IN</sub>-X<sub>OUT</sub>, X<sub>CIN</sub>-X<sub>COU</sub>T may be some differences between 3850 group (standard) and 3850 group (spec. A).
- (3) Be sure to perform the termination of unused pins.

### Handling of Source Pins

In order to avoid a latch-up occurrence, connect a capacitor suitable for high frequencies as bypass capacitor between power source pin ( $V_{CC}$  pin) and GND pin ( $V_{SS}$  pin) and between power source pin ( $V_{CC}$  pin) and analog power source input pin ( $AV_{SS}$  pin). Besides, connect the capacitor to as close as possible. For bypass capacitor which should not be located too far from the pins to be connected, a ceramic capacitor of  $0.01 \mu\text{F}$ – $0.1 \mu\text{F}$  is recommended.

### Power Source Voltage

When the power source voltage value of a microcomputer is less than the value which is indicated as the recommended operating conditions, the microcomputer does not operate normally and may perform unstable operation.

In a system where the power source voltage drops slowly when the power source voltage drops or the power supply is turned off, reset a microcomputer when the power source voltage is less than the recommended operating conditions and design a system not to cause errors to the system by this unstable operation.

### Flash Memory Version

Connect the CNVss/VPP pin the shortest possible to the GND pattern which is supplied to the  $V_{SS}$  pin of the microcomputer. In addition connecting an approximately 1 k to 5 k $\Omega$  resistor in series to the GND could improve noise immunity. In this case as well as the above mention, connect the pin the shortest possible to the GND pattern which is supplied to the  $V_{SS}$  pin of the microcomputer.

#### ●Reason

The CNVss/VPP pin is the power source input pin for the built-in flash memory. When programming in the flash memory, the impedance of the VPP pin is low to allow the electric current for writing to flow into the built-in flash memory. Because of this, noise can enter easily. If noise enters the VPP pin, abnormal instruction codes or data are read from the flash memory, which may cause a program runaway.

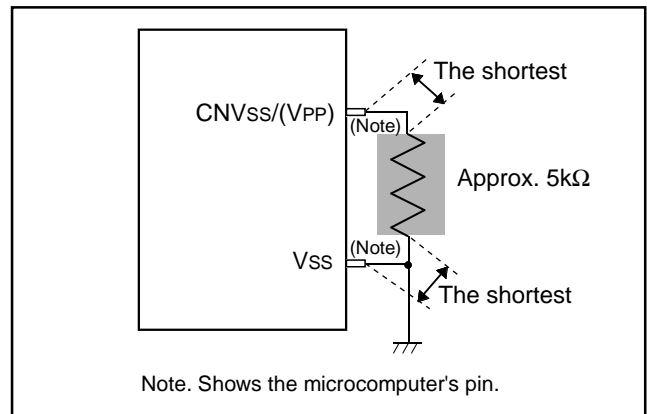

Fig. 67 Wiring for the CNVss/VPP pin

### Electric Characteristic Differences Between Mask ROM and Flash Memory Version MCUs

There are differences in electric characteristics, operation margin, noise immunity, and noise radiation between mask ROM and flash memory version MCUs due to the differences in the manufacturing processes.

When manufacturing an application system with the flash memory and then switching to use of the mask ROM version, perform sufficient evaluations for the commercial samples of the mask ROM version.

### DATA REQUIRED FOR MASK ORDERS

The following are necessary when ordering a mask ROM production:

1. Mask ROM Order Confirmation Form\*
2. Mark Specification Form\*
3. Data to be written to ROM ..... one floppy disk

\*For the mask ROM confirmation, refer to the "Renesas Technology" Homepage Rom ordering (<http://www.renesas.com/homepage.jsp>).

## Electrical characteristics

### Absolute maximum ratings

**Table 17 Absolute maximum ratings**

Symbol	Parameter	Conditions	Ratings	Unit
V <sub>CC</sub>	Power source voltage		-0.3 to 6.5	V
V <sub>I</sub>	Input voltage P00–P07, P10–P17, P20, P21, P24–P27, P30–P34, P40–P44, V <sub>REF</sub>	All voltages are based on V <sub>SS</sub> . When an input voltage is measured, output transistors are cut off.	-0.3 to V <sub>CC</sub> +0.3	V
V <sub>I</sub>	Input voltage P22, P23		-0.3 to 5.8	V
V <sub>I</sub>	Input voltage RESET, X <sub>IN</sub>		-0.3 to V <sub>CC</sub> +0.3	V
V <sub>I</sub>	Input voltage CNV <sub>SS</sub>		-0.3 to V <sub>CC</sub> +0.3	V
V <sub>O</sub>	Output voltage P00–P07, P10–P17, P20, P21, P24–P27, P30–P34, P40–P44, X <sub>OUT</sub>		-0.3 to V <sub>CC</sub> +0.3	V
V <sub>O</sub>	Output voltage P22, P23		-0.3 to 5.8	V
P <sub>d</sub>	Power dissipation	T <sub>a</sub> = 25 °C	1000 <b>(Note)</b>	mW
T <sub>opr</sub>	Operating temperature		-20 to 85	°C
T <sub>stg</sub>	Storage temperature		-40 to 125	°C

**Note :** The rating becomes 300mW at the PRSP0042GA-B package.

## Recommended operating conditions

**Table 18 Recommended operating conditions (1)**

(V<sub>CC</sub> = 2.7 to 5.5 V, T<sub>a</sub> = -20 to 85 °C, unless otherwise noted)

Symbol	Parameter		Limits			Unit
			Min.	Typ.	Max.	
V <sub>CC</sub>	Power source voltage	12.5 MHz (high-speed mode)	4.0	5.0	5.5	V
		12.5 MHz (middle-speed mode), 6 MHz (high-speed mode)	2.7	5.0	5.5	
		32 kHz (low-speed mode)				
V <sub>SS</sub>	Power source voltage			0		V
V <sub>REF</sub>	A/D convert reference voltage		2.0		V <sub>CC</sub>	V
AV <sub>SS</sub>	Analog power source voltage			0		V
V <sub>IA</sub>	Analog input voltage	AN <sub>0</sub> –AN <sub>8</sub>	AV <sub>SS</sub>		V <sub>CC</sub>	V
V <sub>IH</sub>	“H” input voltage	P0 <sub>0</sub> –P0 <sub>7</sub> , P1 <sub>0</sub> –P1 <sub>7</sub> , P2 <sub>0</sub> , P2 <sub>1</sub> , P2 <sub>4</sub> –P2 <sub>7</sub> , P3 <sub>0</sub> –P3 <sub>4</sub> , P4 <sub>0</sub> –P4 <sub>4</sub>	0.8V <sub>CC</sub>		V <sub>CC</sub>	V
V <sub>IH</sub>	“H” input voltage	P2 <sub>2</sub> , P2 <sub>3</sub>	0.8V <sub>CC</sub>		5.8	V
V <sub>IH</sub>	“H” input voltage	RESET, X <sub>IN</sub> , CNV <sub>SS</sub>	0.8V <sub>CC</sub>		V <sub>CC</sub>	V
V <sub>IL</sub>	“L” input voltage	P0 <sub>0</sub> –P0 <sub>7</sub> , P1 <sub>0</sub> –P1 <sub>7</sub> , P2 <sub>0</sub> –P2 <sub>7</sub> , P3 <sub>0</sub> –P3 <sub>4</sub> , P4 <sub>0</sub> –P4 <sub>4</sub>	0		0.2V <sub>CC</sub>	V
V <sub>IL</sub>	“L” input voltage	RESET, CNV <sub>SS</sub>	0		0.2V <sub>CC</sub>	V
V <sub>IL</sub>	“L” input voltage	X <sub>IN</sub>	0		0.16V <sub>CC</sub>	V
ΣIOH(peak)	“H” total peak output current (Note) P0 <sub>0</sub> –P0 <sub>7</sub> , P1 <sub>0</sub> –P1 <sub>7</sub> , P3 <sub>0</sub> –P3 <sub>4</sub>				–80	mA
ΣIOH(peak)	“H” total peak output current (Note) P2 <sub>0</sub> , P2 <sub>1</sub> , P2 <sub>4</sub> –P2 <sub>7</sub> , P4 <sub>0</sub> –P4 <sub>4</sub>				–80	mA
ΣIOL(peak)	“L” total peak output current (Note) P0 <sub>0</sub> –P0 <sub>7</sub> , P3 <sub>0</sub> –P3 <sub>4</sub>				80	mA
ΣIOL(peak)	“L” total peak output current (Note) P1 <sub>0</sub> –P1 <sub>7</sub>				120	mA
ΣIOL(peak)	“L” total peak output current (Note) P2 <sub>0</sub> –P2 <sub>7</sub> , P4 <sub>0</sub> –P4 <sub>4</sub>				80	mA
ΣIOH(avg)	“H” total average output current (Note) P0 <sub>0</sub> –P0 <sub>7</sub> , P1 <sub>0</sub> –P1 <sub>7</sub> , P3 <sub>0</sub> –P3 <sub>4</sub>				–40	mA
ΣIOH(avg)	“H” total average output current (Note) P2 <sub>0</sub> , P2 <sub>1</sub> , P2 <sub>4</sub> –P2 <sub>7</sub> , P4 <sub>0</sub> –P4 <sub>4</sub>				–40	mA
ΣIOL(avg)	“L” total average output current (Note) P0 <sub>0</sub> –P0 <sub>7</sub> , P3 <sub>0</sub> –P3 <sub>4</sub>				40	mA
ΣIOL(avg)	“L” total average output current (Note) P1 <sub>0</sub> –P1 <sub>7</sub>				60	mA
ΣIOL(avg)	“L” total average output current (Note) P2 <sub>0</sub> –P2 <sub>7</sub> , P4 <sub>0</sub> –P4 <sub>4</sub>				40	mA

**Note :** The total output current is the sum of all the currents flowing through all the applicable ports. The total average current is an average value measured over 100 ms. The total peak current is the peak value of all the currents.

**Table 19 Recommended operating conditions (2)**  
**(V<sub>CC</sub> = 2.7 to 5.5 V, T<sub>a</sub> = -20 to 85 °C, unless otherwise noted)**

Symbol	Parameter	Limits			Unit
		Min.	Typ.	Max.	
I <sub>OH</sub> (peak)	"H" peak output current P00–P07, P10–P17, P20, P21, P24–P27, P30–P34, P40–P44 (Note 1)			-10	mA
I <sub>OL</sub> (peak)	"L" peak output current (Note 1) P00–P07, P20–P27, P30–P34, P40–P44			10	mA
	P10–P17			20	mA
I <sub>OH</sub> (avg)	"H" average output current P00–P07, P10–P17, P20, P21, P24–P27, P30–P34, P40–P44 (Note 2)			-5	mA
I <sub>OL</sub> (avg)	"L" average output current (Note 2) P00–P07, P20–P27, P30–P34, P40–P44			5	mA
	P10–P17			15	mA
f(XIN)	Internal clock oscillation frequency (V <sub>CC</sub> = 4.0 to 5.5 V) (Note 3)			12.5	MHz
f(XIN)	Internal clock oscillation frequency (V <sub>CC</sub> = 2.7 to 4.0 V) (Note 3)			<sup>5</sup> V <sub>CC</sub> -7.5	MHz
f(XCIN)	Sub-clock input oscillation frequency (Note 3, 4)		32.768	50	kHz

**Notes** 1: The peak output current is the peak current flowing in each port.

2: The average output current I<sub>OL</sub>(avg), I<sub>OH</sub>(avg) are average value measured over 100 ms.

3: When the oscillation frequency has a duty cycle of 50%.

4: When using the microcomputer in low-speed mode, set the sub-clock input oscillation frequency on condition that f(XCIN) < f(XIN)/3.

## Electrical characteristics

**Table 20 Electrical characteristics (1)**  
**(V<sub>CC</sub> = 2.7 to 5.5 V, V<sub>SS</sub> = 0 V, T<sub>a</sub> = -20 to 85 °C, unless otherwise noted)**

Symbol	Parameter	Test conditions	Limits			Unit
			Min.	Typ.	Max.	
V <sub>OH</sub>	"H" output voltage P00–P07, P10–P17, P20, P21, P24–P27, P30–P34, P40–P44 (Note)	I <sub>OH</sub> = -10 mA V <sub>CC</sub> = 4.0–5.5 V	V <sub>CC</sub> -2.0			V
		I <sub>OH</sub> = -1.0 mA V <sub>CC</sub> = 2.7–5.5 V	V <sub>CC</sub> -1.0			V
V <sub>OL</sub>	"L" output voltage P00–P07, P20–P27, P30–P34, P40–P44	I <sub>OL</sub> = 10 mA V <sub>CC</sub> = 4.0–5.5 V			2.0	V
		I <sub>OL</sub> = 1.0 mA V <sub>CC</sub> = 2.7–5.5 V			1.0	V
		I <sub>OL</sub> = 20 mA V <sub>CC</sub> = 4.0–5.5 V			2.0	V
V <sub>OL</sub>	"L" output voltage P10–P17	I <sub>OL</sub> = 10 mA V <sub>CC</sub> = 2.7–5.5 V			1.0	V

**Note:** P<sub>25</sub> is measured when the P<sub>25</sub>/TXD P-channel output disable bit of the UART control register (bit 4 of address 001B16) is "0".



**Table 21 Electrical characteristics (2)****(V<sub>CC</sub> = 2.7 to 5.5 V, V<sub>SS</sub> = 0 V, T<sub>a</sub> = -20 to 85 °C, unless otherwise noted)**

Symbol	Parameter	Test conditions	Limits			Unit
			Min.	Typ.	Max.	
V <sub>T+</sub> -V <sub>T-</sub>	Hysteresis CNTR <sub>0</sub> , CNTR <sub>1</sub> , INT <sub>0</sub> -INT <sub>3</sub>			0.4		V
V <sub>T+</sub> -V <sub>T-</sub>	Hysteresis RxD, SCLK <sub>1</sub> , SCLK <sub>2</sub> , SIN <sub>2</sub>			0.5		V
V <sub>T+</sub> -V <sub>T-</sub>	Hysteresis RESET			0.5		V
I <sub>IH</sub>	"H" input current P0 <sub>0</sub> -P0 <sub>7</sub> , P1 <sub>0</sub> -P1 <sub>7</sub> , P2 <sub>0</sub> , P2 <sub>1</sub> , P2 <sub>4</sub> -P2 <sub>7</sub> , P3 <sub>0</sub> -P3 <sub>4</sub> , P4 <sub>0</sub> -P4 <sub>4</sub>	V <sub>I</sub> = V <sub>CC</sub> Pin floating, Pull-up Transistor "off"			5.0	μA
I <sub>IH</sub>	"H" input current RESET, CNV <sub>SS</sub>	V <sub>I</sub> = V <sub>CC</sub>			5.0	μA
I <sub>IH</sub>	"H" input current X <sub>IN</sub>	V <sub>I</sub> = V <sub>CC</sub>		4		μA
I <sub>IL</sub>	"L" input current P0 <sub>0</sub> -P0 <sub>7</sub> , P1 <sub>0</sub> -P1 <sub>7</sub> , P2 <sub>0</sub> -P2 <sub>7</sub> P3 <sub>0</sub> -P3 <sub>4</sub> , P4 <sub>0</sub> -P4 <sub>4</sub>	V <sub>I</sub> = V <sub>SS</sub> Pin floating, Pull-up Transistor "off"			-5.0	μA
I <sub>IL</sub>	"L" input current RESET, CNV <sub>SS</sub>	V <sub>I</sub> = V <sub>SS</sub>			-5.0	μA
I <sub>IL</sub>	"L" input current X <sub>IN</sub>	V <sub>I</sub> = V <sub>SS</sub>		-4		μA
I <sub>IL</sub>	"L" input current (at Pull-up) P0 <sub>0</sub> -P0 <sub>7</sub> , P1 <sub>0</sub> -P1 <sub>7</sub> , P2 <sub>0</sub> , P2 <sub>1</sub> , P2 <sub>4</sub> -P2 <sub>7</sub> , P3 <sub>0</sub> -P3 <sub>4</sub> , P4 <sub>0</sub> -P4 <sub>4</sub>	V <sub>I</sub> = V <sub>SS</sub> V <sub>CC</sub> = 5.0 V	-25	-65	-120	μA
		V <sub>I</sub> = V <sub>SS</sub>	-8	-22	-40	μA
		V <sub>I</sub> = 3.0 V				
VRAM	RAM hold voltage	When clock stopped	2.0		5.5	V

**Table 22 Electrical characteristics (3)**(V<sub>CC</sub> = 2.7 to 5.5 V, V<sub>SS</sub> = 0 V, T<sub>a</sub> = -20 to 85 °C, unless otherwise noted)

Symbol	Parameter	Test conditions		Limits			Unit
				Min.	Typ.	Max.	
I <sub>CC</sub>	Power source current	High-speed mode f(X <sub>IN</sub> ) = 12.5 MHz f(XC <sub>IN</sub> ) = 32.768 kHz Output transistors "off"	Except M38507F8AFP/SP		6.5	13.0	mA
			M38507F8AFP/SP		7.5	15.0	mA
		High-speed mode f(X <sub>IN</sub> ) = 8 MHz f(XC <sub>IN</sub> ) = 32.768 kHz Output transistors "off"	Except M38507F8AFP/SP		5.0	10	mA
			M38507F8AFP/SP		6.8	13	mA
		High-speed mode f(X <sub>IN</sub> ) = 12.5 MHz (in WIT state) f(XC <sub>IN</sub> ) = 32.768 kHz Output transistors "off"			1.6	4.5	mA
		High-speed mode f(X <sub>IN</sub> ) = 8 MHz (in WIT state) f(XC <sub>IN</sub> ) = 32.768 kHz Output transistors "off"			1.6	4.2	mA
		Middle-speed mode f(X <sub>IN</sub> ) = 12.5 MHz f(XC <sub>IN</sub> ) = stopped Output transistors "off"	Except M38507F8AFP/SP		4.0	7.0	mA
			M38507F8AFP/SP		4.0	8.5	mA
		Middle-speed mode f(X <sub>IN</sub> ) = 8 MHz f(XC <sub>IN</sub> ) = stopped Output transistors "off"	Except M38507F8AFP/SP		3.0	6.5	mA
			M38507F8AFP/SP		3.0	7.0	mA
		Middle-speed mode f(X <sub>IN</sub> ) = 12.5 MHz (in WIT state) f(XC <sub>IN</sub> ) = stopped Output transistors "off"			1.5	4.2	mA
		Middle-speed mode f(X <sub>IN</sub> ) = 8 MHz (in WIT state) f(XC <sub>IN</sub> ) = stopped Output transistors "off"			1.5	4.0	mA
		Low-speed mode f(X <sub>IN</sub> ) = stopped f(XC <sub>IN</sub> ) = 32.768 kHz Output transistors "off"	Except M38507F8AFP/SP		60	200	μA
			M38507F8AFP/SP		250	500	μA
		Low-speed mode f(X <sub>IN</sub> ) = stopped f(XC <sub>IN</sub> ) = 32.768 kHz (in WIT state) Output transistors "off"	Except M38507F8AFP/SP		40	70	μA
			M38507F8AFP/SP		70	150	μA
		Low-speed mode (V <sub>CC</sub> = 3 V) f(X <sub>IN</sub> ) = stopped f(XC <sub>IN</sub> ) = 32.768 kHz Output transistors "off"	Except M38507F8AFP/SP		20	55	μA
			M38507F8AFP/SP		150	300	μA
		Low-speed mode (V <sub>CC</sub> = 3 V) f(X <sub>IN</sub> ) = stopped f(XC <sub>IN</sub> ) = 32.768 kHz (in WIT state) Output transistors "off"	Except M38507F8AFP/SP		5	10	μA
			M38507F8AFP/SP		20	40	μA
Increment when A/D conversion is executed f(X <sub>IN</sub> ) = 8 MHz			800		μA		
All oscillation stopped (in STP state) Output transistors "off"	T <sub>a</sub> = 25 °C		0.1	1.0	μA		
	T <sub>a</sub> = 85 °C			10	μA		

**A/D converter characteristics****Table 23 A/D converter characteristics****(V<sub>CC</sub> = 2.7 to 5.5 V, V<sub>SS</sub> = AV<sub>SS</sub> = 0 V, T<sub>a</sub> = -20 to 85 °C, f(X<sub>IN</sub>) = 12.5 MHz, unless otherwise noted)**

Symbol	Parameter		Test conditions	Limits			Unit
				Min.	Typ.	Max.	
–	Resolution					10	bit
–	Absolute accuracy (excluding quantization error)					±4	LSB
t <sub>CONV</sub>	Conversion time		High-speed mode, Middle-speed mode			61	2t <sub>c</sub> (X <sub>IN</sub> )
			Low-speed mode		40		μs
RLADDER	Ladder resistor				35		kΩ
I <sub>VREF</sub>	Reference power source input current	V <sub>REF</sub> "on"	V <sub>REF</sub> = 5.0 V	50	150	200	μA
		V <sub>REF</sub> "off"				5.0	
I <sub>I(AD)</sub>	A/D port input current				0.5	5.0	μA

## Timing requirements

**Table 24 Timing requirements (1)**
**(V<sub>CC</sub> = 4.0 to 5.5 V, V<sub>SS</sub> = 0 V, T<sub>a</sub> = -20 to 85 °C, unless otherwise noted)**

Symbol	Parameter	Limits			Unit
		Min.	Typ.	Max.	
t <sub>w</sub> (RESET)	Reset input "L" pulse width	20			XIN cycle
t <sub>c</sub> (XIN)	External clock input cycle time	80			ns
t <sub>WH</sub> (XIN)	External clock input "H" pulse width	32			ns
t <sub>WL</sub> (XIN)	External clock input "L" pulse width	32			ns
t <sub>c</sub> (CNTR)	CNTR0, CNTR1 input cycle time	200			ns
t <sub>WH</sub> (CNTR)	CNTR0, CNTR1 input "H" pulse width	80			ns
t <sub>WL</sub> (CNTR)	CNTR0, CNTR1 input "L" pulse width	80			ns
t <sub>WH</sub> (INT)	INT0 to INT3 input "H" pulse width	80			ns
t <sub>WL</sub> (INT)	INT0 to INT3 input "L" pulse width	80			ns
t <sub>c</sub> (SCLK1)	Serial I/O1 clock input cycle time <b>(Note)</b>	800			ns
t <sub>WH</sub> (SCLK1)	Serial I/O1 clock input "H" pulse width <b>(Note)</b>	370			ns
t <sub>WL</sub> (SCLK1)	Serial I/O1 clock input "L" pulse width <b>(Note)</b>	370			ns
t <sub>su</sub> (RxD-SCLK1)	Serial I/O1 input setup time	220			ns
t <sub>h</sub> (SCLK1-RxD)	Serial I/O1 input hold time	100			ns
t <sub>c</sub> (SCLK2)	Serial I/O2 clock input cycle time	1000			ns
t <sub>WH</sub> (SCLK2)	Serial I/O2 clock input "H" pulse width	400			ns
t <sub>WL</sub> (SCLK2)	Serial I/O2 clock input "L" pulse width	400			ns
t <sub>su</sub> (SIN2-SCLK2)	Serial I/O2 clock input setup time	200			ns
t <sub>h</sub> (SCLK2-SIN2)	Serial I/O2 clock input hold time	200			ns

**Note :** When f(XIN) = 8 MHz and bit 6 of address 001A16 is "1" (clock synchronous).  
Divide this value by four when f(XIN) = 8 MHz and bit 6 of address 001A16 is "0" (UART).

**Table 25 Timing requirements (2)**
**(V<sub>CC</sub> = 2.7 to 5.5 V, V<sub>SS</sub> = 0 V, T<sub>a</sub> = -20 to 85 °C, unless otherwise noted)**

Symbol	Parameter	Limits			Unit
		Min.	Typ.	Max.	
t <sub>w</sub> (RESET)	Reset input "L" pulse width	20			XIN cycle
t <sub>c</sub> (XIN)	External clock input cycle time	166			ns
t <sub>WH</sub> (XIN)	External clock input "H" pulse width	66			ns
t <sub>WL</sub> (XIN)	External clock input "L" pulse width	66			ns
t <sub>c</sub> (CNTR)	CNTR0, CNTR1 input cycle time	500			ns
t <sub>WH</sub> (CNTR)	CNTR0, CNTR1 input "H" pulse width	230			ns
t <sub>WL</sub> (CNTR)	CNTR0, CNTR1 input "L" pulse width	230			ns
t <sub>WH</sub> (INT)	INT0 to INT3 input "H" pulse width	230			ns
t <sub>WL</sub> (INT)	INT0 to INT3 input "L" pulse width	230			ns
t <sub>c</sub> (SCLK1)	Serial I/O1 clock input cycle time <b>(Note)</b>	2000			ns
t <sub>WH</sub> (SCLK1)	Serial I/O1 clock input "H" pulse width <b>(Note)</b>	950			ns
t <sub>WL</sub> (SCLK1)	Serial I/O1 clock input "L" pulse width <b>(Note)</b>	950			ns
t <sub>su</sub> (RxD-SCLK1)	Serial I/O1 input setup time	400			ns
t <sub>h</sub> (SCLK1-RxD)	Serial I/O1 input hold time	200			ns
t <sub>c</sub> (SCLK2)	Serial I/O2 clock input cycle time	2000			ns
t <sub>WH</sub> (SCLK2)	Serial I/O2 clock input "H" pulse width	950			ns
t <sub>WL</sub> (SCLK2)	Serial I/O2 clock input "L" pulse width	950			ns
t <sub>su</sub> (SIN2-SCLK2)	Serial I/O2 clock input setup time	400			ns
t <sub>h</sub> (SCLK2-SIN2)	Serial I/O2 clock input hold time	300			ns

**Note :** When f(XIN) = 4 MHz and bit 6 of address 001A16 is "1" (clock synchronous).  
Divide this value by four when f(XIN) = 4 MHz and bit 6 of address 001A16 is "0" (UART).

## Switching characteristics

**Table 26 Switching characteristics (1)**
**(V<sub>CC</sub> = 4.0 to 5.5 V, V<sub>SS</sub> = 0 V, T<sub>a</sub> = -20 to 85 °C, unless otherwise noted)**

Symbol	Parameter	Test conditions	Limits			Unit
			Min.	Typ.	Max.	
t <sub>WH</sub> (SCLK1)	Serial I/O1 clock output "H" pulse width	Fig. 67	tc(SCLK1)/2-30			ns
t <sub>WL</sub> (SCLK1)	Serial I/O1 clock output "L" pulse width		tc(SCLK1)/2-30			ns
t <sub>d</sub> (SCLK1-TxD)	Serial I/O1 output delay time ( <b>Note 1</b> )				140	ns
t <sub>v</sub> (SCLK1-TxD)	Serial I/O1 output valid time ( <b>Note 1</b> )		-30			ns
t <sub>r</sub> (SCLK1)	Serial I/O1 clock output rising time				30	ns
t <sub>f</sub> (SCLK1)	Serial I/O1 clock output falling time				30	ns
t <sub>WH</sub> (SCLK2)	Serial I/O2 clock output "H" pulse width		tc(SCLK2)/2-160			ns
t <sub>WL</sub> (SCLK2)	Serial I/O2 clock output "L" pulse width		tc(SCLK2)/2-160			ns
t <sub>d</sub> (SCLK2-SOUT2)	Serial I/O2 output delay time ( <b>Note 2</b> )				200	ns
t <sub>v</sub> (SCLK2-SOUT2)	Serial I/O2 output valid time ( <b>Note 2</b> )		0			ns
t <sub>f</sub> (SCLK2)	Serial I/O2 clock output falling time				30	ns
t <sub>r</sub> (CMOS)	CMOS output rising time ( <b>Note 3</b> )			10	30	ns
t <sub>f</sub> (CMOS)	CMOS output falling time ( <b>Note 3</b> )			10	30	ns

**Notes 1:** When the P25/TxD P-channel output disable bit of the UART control register (bit 4 of address 001B16) is "0".

**2:** When the P01/SOUT2 and P02/SCLK2 P-channel output disable bit of the Serial I/O2 control register 1 (bit 7 of address 001516) is "0".

**3:** The XOUT pin is excluded.

**Table 27 Switching characteristics (2)**
**(V<sub>CC</sub> = 2.7 to 5.5 V, V<sub>SS</sub> = 0 V, T<sub>a</sub> = -20 to 85 °C, unless otherwise noted)**

Symbol	Parameter	Test conditions	Limits			Unit
			Min.	Typ.	Max.	
t <sub>WH</sub> (SCLK1)	Serial I/O1 clock output "H" pulse width	Fig. 67	tc(SCLK1)/2-50			ns
t <sub>WL</sub> (SCLK1)	Serial I/O1 clock output "L" pulse width		tc(SCLK1)/2-50			ns
t <sub>d</sub> (SCLK1-TxD)	Serial I/O1 output delay time ( <b>Note 1</b> )				350	ns
t <sub>v</sub> (SCLK1-TxD)	Serial I/O1 output valid time ( <b>Note 1</b> )		-30			ns
t <sub>r</sub> (SCLK1)	Serial I/O1 clock output rising time				50	ns
t <sub>f</sub> (SCLK1)	Serial I/O1 clock output falling time				50	ns
t <sub>WH</sub> (SCLK2)	Serial I/O2 clock output "H" pulse width		tc(SCLK2)/2-240			ns
t <sub>WL</sub> (SCLK2)	Serial I/O2 clock output "L" pulse width		tc(SCLK2)/2-240			ns
t <sub>d</sub> (SCLK2-SOUT2)	Serial I/O2 output delay time ( <b>Note 2</b> )				400	ns
t <sub>v</sub> (SCLK2-SOUT2)	Serial I/O2 output valid time ( <b>Note 2</b> )		0			ns
t <sub>f</sub> (SCLK2)	Serial I/O2 clock output falling time				50	ns
t <sub>r</sub> (CMOS)	CMOS output rising time ( <b>Note 3</b> )			20	50	ns
t <sub>f</sub> (CMOS)	CMOS output falling time ( <b>Note 3</b> )			20	50	ns

**Notes 1:** When the P25/TxD P-channel output disable bit of the UART control register (bit 4 of address 001B16) is "0".

**2:** When the P01/SOUT2 and P02/SCLK2 P-channel output disable bit of the Serial I/O2 control register 1 (bit 7 of address 001516) is "0".

**3:** The XOUT pin is excluded.

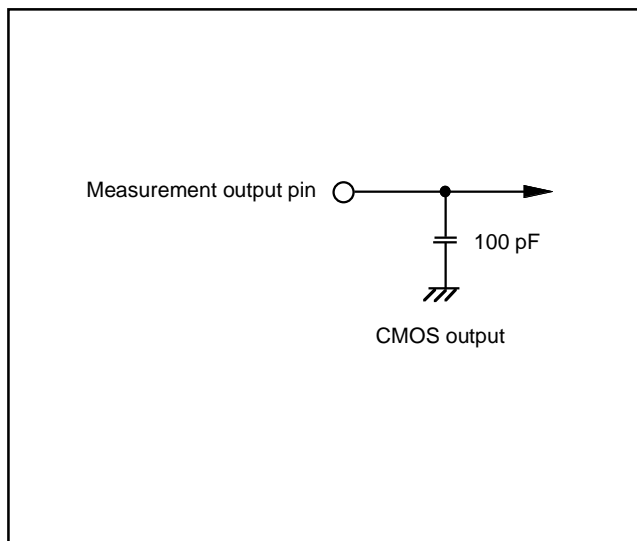

Fig. 68 Circuit for measuring output switching characteristics

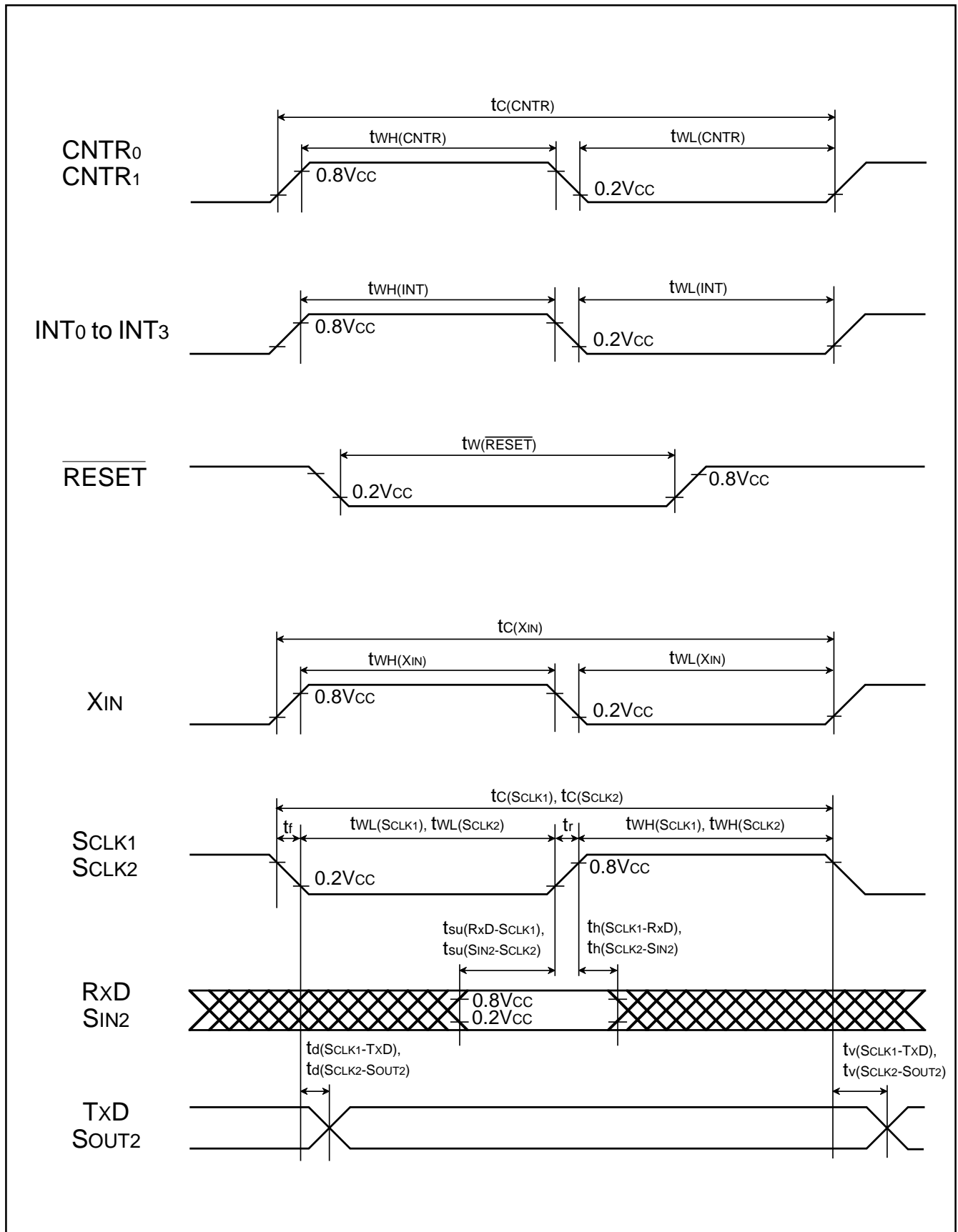
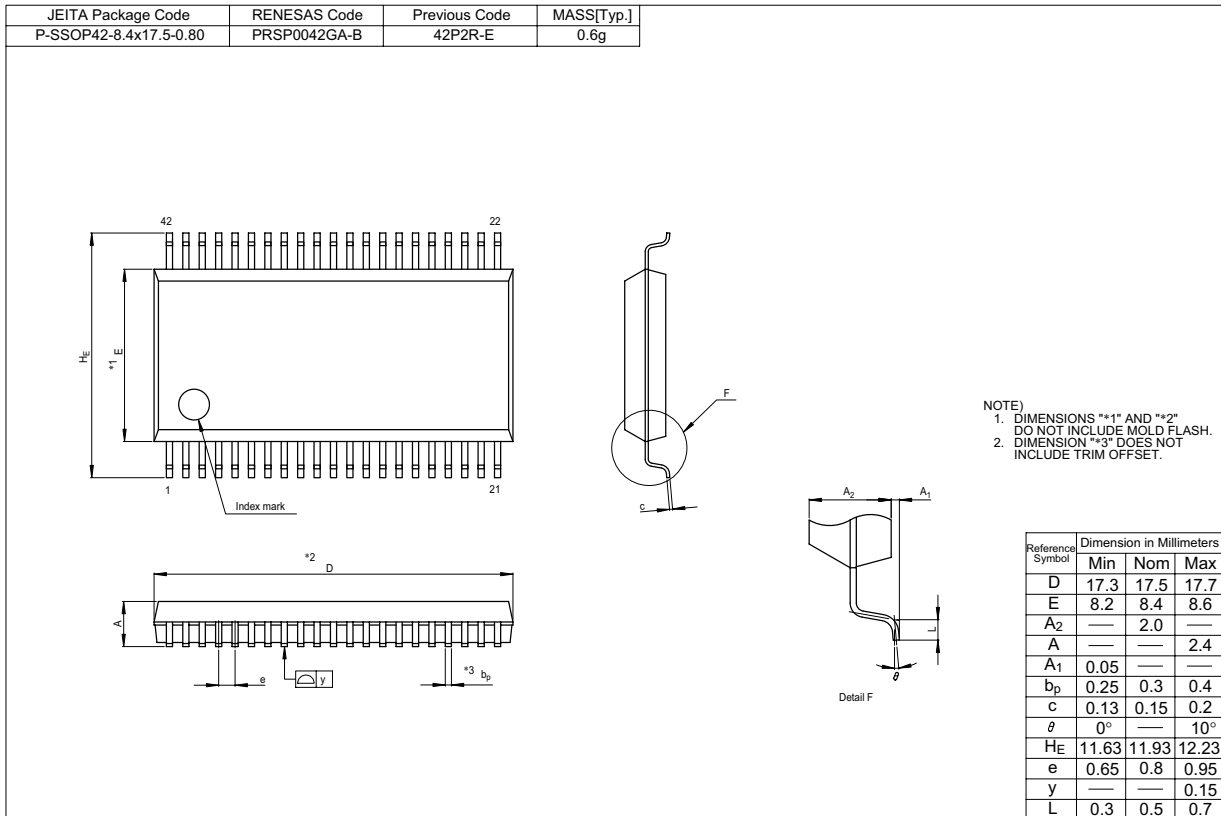
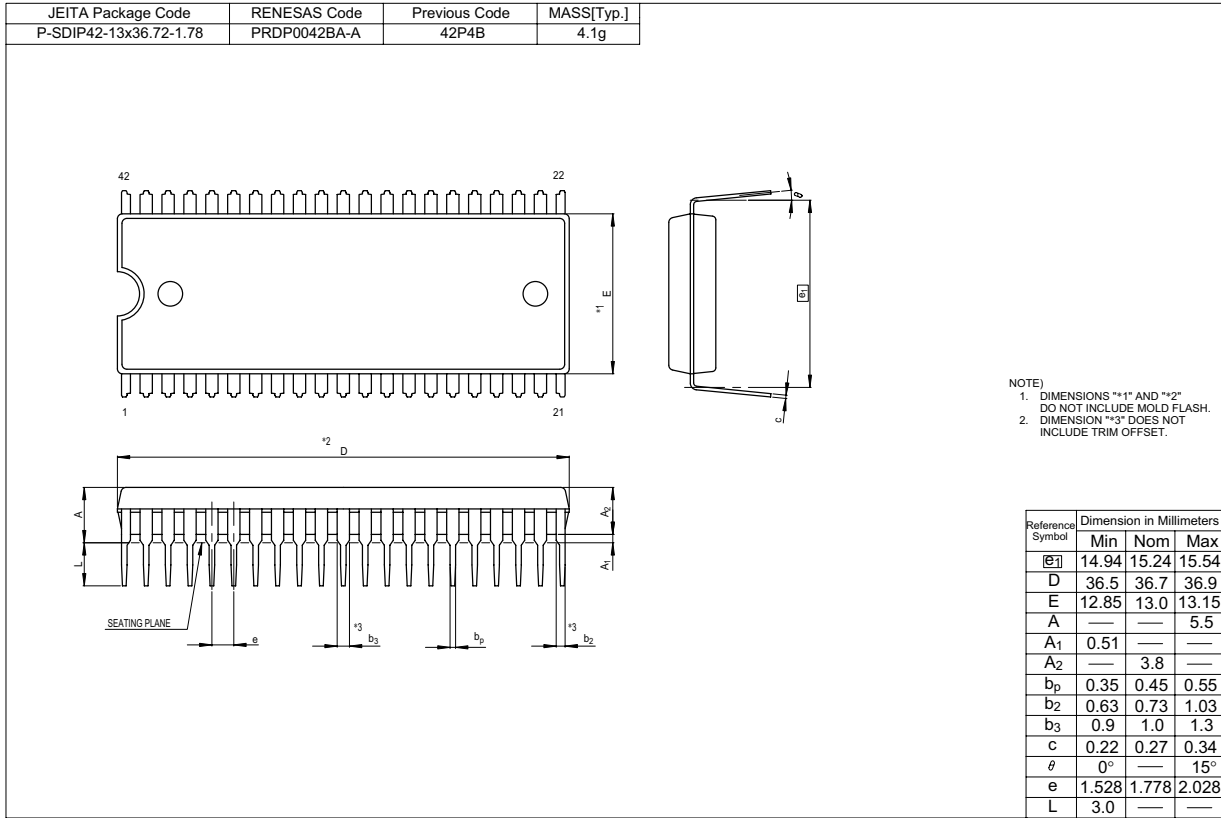

Fig. 69 Timing diagram

PACKAGE OUTLINE





## APPENDIX

## NOTES ON PROGRAMMING

## 1. Processor status register

## (1) Initializing of processor status register

Flags which affect program execution must be initialized after a reset. In particular, it is essential to initialize the T and D flags because they have an important effect on calculations.

<Reason>

After a reset, the contents of the processor status register (PS) are undefined except for the I flag which is "1".

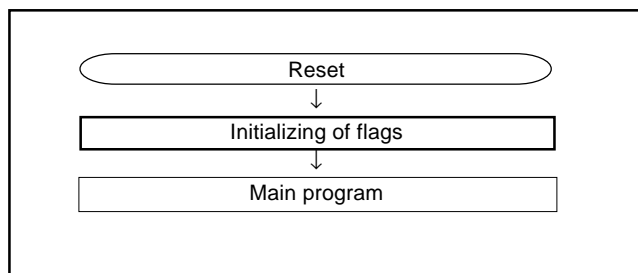

Fig. 1 Initialization of processor status register

## (2) How to reference the processor status register

To reference the contents of the processor status register (PS), execute the **PHP** instruction once then read the contents of (S+1). If necessary, execute the **PLP** instruction to return the PS to its original status.

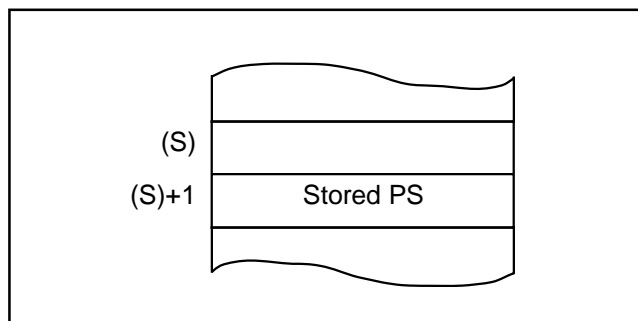

Fig. 2 Stack memory contents after PHP instruction execution

## 2. BRK instruction

## (1) Interrupt priority level

When the BRK instruction is executed with the following conditions satisfied, the interrupt execution is started from the address of interrupt vector which has the highest priority.

- Interrupt request bit and interrupt enable bit are set to "1".
- Interrupt disable flag (I) is set to "1" to disable interrupt.

## 3. Decimal calculations

## (1) Execution of decimal calculations

The **ADC** and **SBC** are the only instructions which will yield proper decimal notation, set the decimal mode flag (D) to "1" with the **SED** instruction. After executing the **ADC** or **SBC** instruction, execute another instruction before executing the **SEC**, **CLC**, or **CLD** instruction.

## (2) Notes on status flag in decimal mode

When decimal mode is selected, the values of three of the flags in the status register (the N, V, and Z flags) are invalid after a **ADC** or **SBC** instruction is executed.

The carry flag (C) is set to "1" if a carry is generated as a result of the calculation, or is cleared to "0" if a borrow is generated. To determine whether a calculation has generated a carry, the C flag must be initialized to "0" before each calculation. To check for a borrow, the C flag must be initialized to "1" before each calculation.

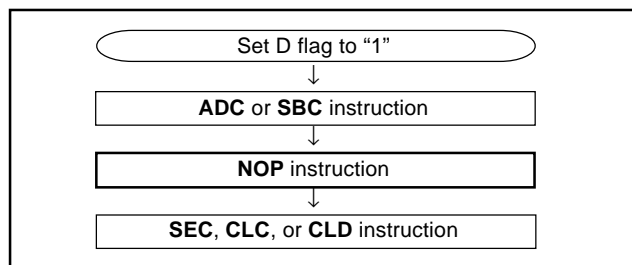

Fig. 3 Execution of decimal calculations

## 4. JMP instruction

When using the **JMP** instruction in indirect addressing mode, do not specify the last address on a page as an indirect address.

## 5. Multiplication and Division Instructions

- The index X mode (T) and the decimal mode (D) flags do not affect the **MUL** and **DIV** instruction.
- The execution of these instructions does not change the contents of the processor status register.

## 6. Ports

The contents of the port direction registers cannot be read. The following cannot be used:

- The data transfer instruction (**LDA**, etc.)
- The operation instruction when the index X mode flag (T) is "1"
- The addressing mode which uses the value of a direction register as an index
- The bit-test instruction (**BBC** or **BBS**, etc.) to a direction register
- The read-modify-write instructions (**ROR**, **CLB**, or **SEB**, etc.) to a direction register.

Use instructions such as **LDM** and **STA**, etc., to set the port direction registers.

## 7. Instruction Execution Timing

The instruction execution time can be obtained by multiplying the frequency of the internal clock  $\phi$  by the number of cycles mentioned in the 740 Family Software Manual.

The frequency of the internal clock  $\phi$  is the twice the  $X_{IN}$  cycle in high-speed mode, 8 times the  $X_{IN}$  cycle in middle-speed mode, and the twice the  $X_{CIN}$  in low-speed mode.

## NOTES ON PERIPHERAL FUNCTIONS

### Notes on input and output ports

#### 1. Notes in standby state

In standby state<sup>\*1</sup>, do not make input levels of an I/O port “undefined”, especially for I/O ports of the N-channel open-drain. When setting the N-channel open-drain port as an output, do not make input levels of an I/O port “undefined”, too.

Pull-up (connect the port to VCC) or pull-down (connect the port to VSS) these ports through a resistor.

When determining a resistance value, note the following points:

- External circuit
- Variation of output levels during the ordinary operation

<Reason>

When setting as an input port with its direction register, the transistor becomes the OFF state, which causes the ports to be the high-impedance state.

Accordingly, the potential which is input to the input buffer in a microcomputer is unstable in the state that input levels of an I/O port are “undefined”. This may cause power source current.

In I/O ports of N-channel open-drain, when the contents of the port latch are “1”, even if it is set as an output port with its direction register, it becomes the same phenomenon as the case of an input port.

<sup>\*1</sup> Standby state: stop mode by executing **STP** instruction  
wait mode by executing **WIT** instruction

#### 2. Modifying output data with bit managing instruction

When the port latch of an I/O port is modified with the bit managing instruction<sup>\*2</sup>, the value of the unspecified bit may be changed.  
<Reason>

The bit managing instructions are read-modify-write form instructions for reading and writing data by a byte unit. Accordingly, when these instructions are executed on a bit of the port latch of an I/O port, the following is executed to all bits of the port latch.

- As for bit which is set for input port:  
The pin state is read in the CPU, and is written to this bit after bit managing.
- As for bit which is set for output port:  
The bit value is read in the CPU, and is written to this bit after bit managing.

Note the following:

- Even when a port which is set as an output port is changed for an input port, its port latch holds the output data.
- As for a bit of which is set for an input port, its value may be changed even when not specified with a bit managing instruction in case where the pin state differs from its port latch contents.

<sup>\*2</sup> Bit managing instructions: **SEB** and **CLB** instructions

## Termination of unused pins

### 1. Terminate unused pins

#### (1) I/O ports :

- Set the I/O ports for the input mode and connect them to VCC or VSS through each resistor of 1 kΩ to 10 kΩ. In the port which can select an internal pull-up resistor, the internal pull-up resistor can be used.

Set the I/O ports for the output mode and open them at “L” or “H”.

- When opening them in the output mode, the input mode of the initial status remains until the mode of the ports is switched over to the output mode by the program after reset. Thus, the potential at these pins is undefined and the power source current may increase in the input mode. With regard to an effects on the system, thoroughly perform system evaluation on the user side.
- Since the direction register setup may be changed because of a program runaway or noise, set direction registers by program periodically to increase the reliability of program.

#### (2) The AVss pin when not using the A/D converter :

- When not using the A/D converter, handle a power source pin for the A/D converter, AVss pin as follows:  
AVss: Connect to the Vss pin.

### 2. Termination remarks

#### (1) Input ports and I/O ports :

Do not open in the input mode.

<Reason>

- The power source current may increase depending on the first-stage circuit.
- An effect due to noise may be easily produced as compared with proper termination (1) in 1 shown on the above.

#### (2) I/O ports :

When setting for the input mode, do not connect to VCC or VSS directly.

<Reason>

If the direction register setup changes for the output mode because of a program runaway or noise, a short circuit may occur between a port and VCC (or Vss).

#### (3) I/O ports :

When setting for the input mode, do not connect multiple ports in a lump to VCC or VSS through a resistor.

<Reason>

If the direction register setup changes for the output mode because of a program runaway or noise, a short circuit may occur between ports.

- At the termination of unused pins, perform wiring at the shortest possible distance (20 mm or less) from microcomputer pins.

## Notes on Interrupts

### 1. Change of relevant register settings

When the setting of the following registers or bits is changed, the interrupt request bit may be set to "1". When not requiring the interrupt occurrence synchronized with these setting, take the following sequence.

- Interrupt edge selection register (address 3A16)
- Timer XY mode register (address 2316)

Set the above listed registers or bits as the following sequence.

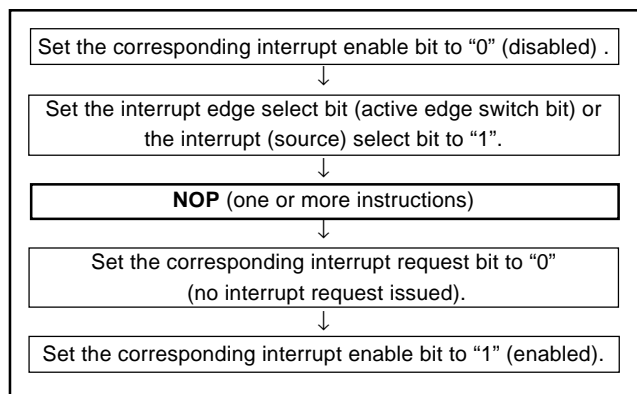

Fig. 4 Sequence of changing relevant register

<Reason>

When setting the followings, the interrupt request bit may be set to "1".

- When setting external interrupt active edge  
Concerned register: Interrupt edge selection register (address 3A16)  
Timer XY mode register (address 2316)
- When switching interrupt sources of an interrupt vector address where two or more interrupt sources are allocated.  
Concerned register: Interrupt edge selection register (address 3A16)

### 2. Check of interrupt request bit

When executing the **BBC** or **BBS** instruction to an interrupt request bit of an interrupt request register immediately after this bit is set to "0" by using a data transfer instruction, execute one or more instructions before executing the **BBC** or **BBS** instruction.

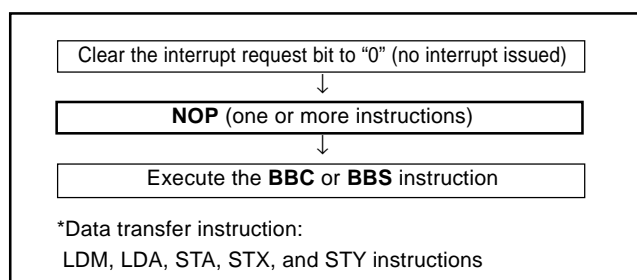

Fig. 5 Sequence of check of interrupt request bit

<Reason>

If the BBC or BBS instruction is executed immediately after an interrupt request bit of an interrupt request register is cleared to "0", the value of the interrupt request bit before being cleared to "0" is read.

## Notes on timer

- If a value  $n$  (between 0 and 255) is written to a timer latch, the frequency division ratio is  $1/(n+1)$ .
- When switching the count source by the timer 12, X and Y count source selection bits, the value of timer count is altered in unconsiderable amount owing to generating of thin pulses in the count input signals.  
Therefore, select the timer count source before set the value to the prescaler and the timer.

## Notes on serial interface

### 1. Notes when selecting clock synchronous serial I/O (Serial I/O1)

#### (1) Stop of transmission operation

Clear the serial I/O1 enable bit and the transmit enable bit to "0" (Serial I/O1 and transmit disabled).

<Reason>

Since transmission is not stopped and the transmission circuit is not initialized even if only the serial I/O1 enable bit is cleared to "0" (Serial I/O1 disabled), the internal transmission is running (in this case, since pins TxD, RxD, SCLK1, and  $\overline{\text{SRDY1}}$  function as I/O ports, the transmission data is not output). When data is written to the transmit buffer register in this state, data starts to be shifted to the transmit shift register. When the serial I/O1 enable bit is set to "1" at this time, the data during internally shifting is output to the TxD pin and an operation failure occurs.

#### (2) Stop of receive operation

Clear the receive enable bit to "0" (receive disabled), or clear the serial I/O1 enable bit to "0" (Serial I/O1 disabled).

#### (3) Stop of transmit/receive operation

Clear the transmit enable bit and receive enable bit to "0" simultaneously (transmit and receive disabled).

(when data is transmitted and received in the clock synchronous serial I/O mode, any one of data transmission and reception cannot be stopped.)

<Reason>

In the clock synchronous serial I/O mode, the same clock is used for transmission and reception. If any one of transmission and reception is disabled, a bit error occurs because transmission and reception cannot be synchronized.

In this mode, the clock circuit of the transmission circuit also operates for data reception. Accordingly, the transmission circuit does not stop by clearing only the transmit enable bit to "0" (transmit disabled). Also, the transmission circuit is not initialized by clearing the serial I/O1 enable bit to "0" (Serial I/O1 disabled) (refer to (1) in 1).

#### (4) $\overline{\text{SRDY1}}$ output of reception side (Serial I/O1)

When signals are output from the  $\overline{\text{SRDY1}}$  pin on the reception side by using an external clock in the clock synchronous serial I/O mode, set all of the receive enable bit, the  $\overline{\text{SRDY1}}$  output enable bit, and the transmit enable bit to "1" (transmit enabled).

## 2. Notes when selecting clock asynchronous serial I/O (Serial I/O1)

## (1) Stop of transmission operation

Clear the transmit enable bit to "0" (transmit disabled).

<Reason>

Since transmission is not stopped and the transmission circuit is not initialized even if only the serial I/O1 enable bit is cleared to "0" (Serial I/O1 disabled), the internal transmission is running (in this case, since pins TxD, RxD, SCLK1, and  $\overline{\text{SRDY1}}$  function as I/O ports, the transmission data is not output). When data is written to the transmit buffer register in this state, data starts to be shifted to the transmit shift register. When the serial I/O1 enable bit is set to "1" at this time, the data during internally shifting is output to the TxD pin and an operation failure occurs.

## (2) Stop of receive operation

Clear the receive enable bit to "0" (receive disabled).

## (3) Stop of transmit/receive operation

Only transmission operation is stopped.

Clear the transmit enable bit to "0" (transmit disabled).

<Reason>

Since transmission is not stopped and the transmission circuit is not initialized even if only the serial I/O1 enable bit is cleared to "0" (Serial I/O1 disabled), the internal transmission is running (in this case, since pins TxD, RxD, SCLK1, and  $\overline{\text{SRDY1}}$  function as I/O ports, the transmission data is not output). When data is written to the transmit buffer register in this state, data starts to be shifted to the transmit shift register. When the serial I/O1 enable bit is set to "1" at this time, the data during internally shifting is output to the TxD pin and an operation failure occurs.

Only receive operation is stopped.

Clear the receive enable bit to "0" (receive disabled).

## 3. Setting serial I/O1 control register again (Serial I/O1)

Set the serial I/O1 control register again after the transmission and the reception circuits are reset by clearing both the transmit enable bit and the receive enable bit to "0".

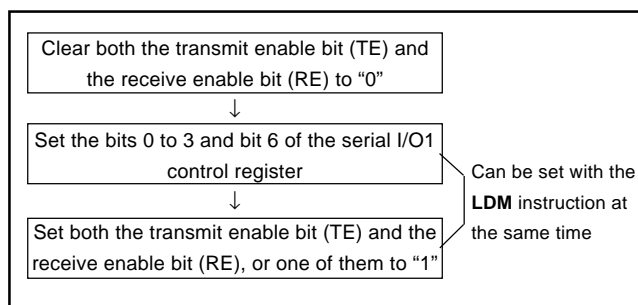

Fig. 6 Sequence of setting serial I/O1 control register again

## 4. Data transmission control with referring to transmit shift register completion flag (Serial I/O1)

The transmit shift register completion flag changes from "1" to "0" with a delay of 0.5 to 1.5 shift clocks. When data transmission is controlled with referring to the flag after writing the data to the transmit buffer register, note the delay.

## 5. Transmit interrupt request when transmit enable bit is set (Serial I/O1)

When the transmit interrupt is used, set the transmit interrupt enable bit to transmit enabled as shown in the following sequence.

(1) Set the interrupt enable bit to "0" (disabled) with CLB instruction.

(2) Prepare serial I/O for transmission/reception.

(3) Set the interrupt request bit to "0" with CLB instruction after 1 or more instruction has been executed.

(4) Set the interrupt enable bit to "1" (enabled).

<Reason>

When the transmission enable bit is set to "1", the transmit buffer empty flag and transmit shift register completion flag are set to "1". The interrupt request is generated and the transmission interrupt request bit is set regardless of which of the two timings listed below is selected as the timing for the transmission interrupt to be generated.

- Transmit buffer empty flag is set to "1"
- Transmit shift register completion flag is set to "1"

## 6. Transmission control when external clock is selected (Serial I/O1 clock synchronous mode)

When an external clock is used as the synchronous clock for data transmission, set the transmit enable bit to "1" at "H" of the SCLK1 input level. Also, write the transmit data to the transmit buffer register (serial I/O shift register) at "H" of the SCLK1 input level.

## 7. Transmit data writing (Serial I/O2)

In the clock synchronous serial I/O, when selecting an external clock as synchronous clock, write the transmit data to the serial I/O2 register (serial I/O shift register) at "H" of the transfer clock input level.

## Notes on PWM

The PWM starts after the PWM enable bit is set to enable and "L" level is output from the PWM pin.

The length of this "L" level output is as follows:

$$\frac{n+1}{2 \cdot f(XIN)} \text{ sec. (Count source selection bit = "0", where } n \text{ is the value set in the prescaler)}$$

$$\frac{n+1}{f(XIN)} \text{ sec. (Count source selection bit = "1", where } n \text{ is the value set in the prescaler)}$$

## Notes on A/D converter

### 1. Analog input pin

Make the signal source impedance for analog input low, or equip an analog input pin with an external capacitor of 0.01  $\mu$ F to 1  $\mu$ F. Further, be sure to verify the operation of application products on the user side.  
<Reason>

An analog input pin includes the capacitor for analog voltage comparison. Accordingly, when signals from signal source with high impedance are input to an analog input pin, charge and discharge noise generates. This may cause the A/D conversion precision to be worse.

### 2. A/D converter power source pin

The AVSS pin is A/D converter power source pin. Regardless of using the A/D conversion function or not, connect it as following :

- AVSS : Connect to the Vss line

<Reason>

If the AVSS pin is opened, the microcomputer may have a failure because of noise or others.

### 3. Clock frequency during A/D conversion

The comparator consists of a capacity coupling, and a charge of the capacity will be lost if the clock frequency is too low. Thus, make sure the following during an A/D conversion.

- f(XIN) is 500 kHz or more in middle-/high-speed mode.
- Do not execute the STP instruction.
- When the A/D converter is operated at low-speed mode, f(XIN) do not have the lower limit of frequency, because of the A/D converter has a built-in self-oscillation circuit.

## Notes on watchdog timer

- Make sure that the watchdog timer does not underflow while waiting Stop release, because the watchdog timer keeps counting during that term.
- When the STP instruction disable bit has been set to "1", it is impossible to switch it to "0" by a program.

## Notes on RESET pin

### 1. Connecting capacitor

In case where the RESET signal rise time is long, connect a ceramic capacitor or others across the RESET pin and the Vss pin. Use a 1000 pF or more capacitor for high frequency use. When connecting the capacitor, note the following :

- Make the length of the wiring which is connected to a capacitor as short as possible.
- Be sure to verify the operation of application products on the user side.

<Reason>

If the several nanosecond or several ten nanosecond impulse noise enters the RESET pin, it may cause a microcomputer failure.

### 2. Reset release after power on

When releasing the reset after power on, such as power-on reset, release reset after XIN passes more than 20 cycles in the state where the power supply voltage is 2.7 V or more and the XIN oscillation is stable.

<Reason>

To release reset, the RESET pin must be held at an "L" level for 20 cycles or more of XIN in the state where the power source voltage is between 2.7 V and 5.5 V, and XIN oscillation is stable.

## Notes on using stop mode

### 1. Register setting

Since values of the prescaler 12 and Timer 1 are automatically reloaded when returning from the stop mode, set them again, respectively. (When the oscillation stabilizing time set after STP instruction released bit is "0")

When using the oscillation stabilizing time set after STP instruction released bit set to "1", evaluate time to stabilize oscillation of the used oscillator and set the value to the timer 1 and prescaler 12.

### 2. Clock restoration

After restoration from the stop mode to the normal mode by an interrupt request, the contents of the CPU mode register previous to the STP instruction execution are retained. Accordingly, if both main clock and sub clock were oscillating before execution of the STP instruction, the oscillation of both clocks is resumed at restoration.

In the above case, when the main clock side is set as a system clock, the oscillation stabilizing time for approximately 8,000 cycles of the XIN input is reserved at restoration from the stop mode. At this time, note that the oscillation on the sub clock side may not be stabilized even after the lapse of the oscillation stabilizing time of the main clock side.

## Notes on wait mode

### • Clock restoration

If the wait mode is released by a reset when XCIN is set as the system clock and XIN oscillation is stopped during execution of the WIT instruction, XCIN oscillation stops, XIN oscillations starts, and XIN is set as the system clock.

In the above case, the RESET pin should be held at "L" until the oscillation is stabilized.

## Notes on CPU rewrite mode of flash memory version

### 1. Operation speed

During CPU rewrite mode, set the internal clock frequency 4MHz or less by using the main clock division ratio selection bits (bits 6, 7 at address 003B16).

### 2. Instructions inhibited against use

The instructions which refer to the internal data of the flash memory cannot be used during CPU rewrite mode .

### 3. Interrupts inhibited against use

The interrupts cannot be used during CPU rewrite mode because they refer to the internal data of the flash memory.

### 4. Watchdog timer

In case of the watchdog timer has been running already, the internal reset generated by watchdog timer underflow does not happen, because of watchdog timer is always clearing during program or erase operation.

### 5. Reset

Reset is always valid. In case of CNVSS = "H" when reset is released, boot mode is active. So the program starts from the address contained in addresses FFFC16 and FFFD16 in boot ROM area.

## Notes on restarting oscillation

### • Restarting oscillation

Usually, when the MCU stops the clock oscillation by STP instruction and the STP instruction has been released by an external interrupt source, the fixed values of Timer 1 and Prescaler 12 (Timer 1 = "0116", Prescaler 12 = "FF16") are automatically re-loaded in order for the oscillation to stabilize. The user can inhibit the automatic setting by writing "1" to bit 0 of MISRG (address 003816).

However, by setting this bit to "1", the previous values, set just before the STP instruction was executed, will remain in Timer 1 and Prescaler 12. Therefore, you will need to set an appropriate value to each register, in accordance with the oscillation stabilizing time, before executing the STP instruction.

<Reason>

Oscillation will restart when an external interrupt is received. However, internal clock  $\phi$  is supplied to the CPU only when Timer 1 starts to underflow. This ensures time for the clock oscillation using the ceramic resonators to be stabilized.

## Flash Memory Version

Connect the CNVSS/VPP pin the shortest possible to the GND pattern which is supplied to the Vss pin of the microcomputer. In addition connecting an approximately 1 k to 5 k $\Omega$  resistor in series to the GND could improve noise immunity. In this case as well as the above mention, connect the pin the shortest possible to the GND pattern which is supplied to the Vss pin of the microcomputer.

### ●Reason

The CNVSS/VPP pin is the power source input pin for the built-in flash memory. When programming in the flash memory, the impedance of the VPP pin is low to allow the electric current for writing to flow into the built-in flash memory. Because of this, noise can enter easily. If noise enters the VPP pin, abnormal instruction codes or data are read from the flash memory, which may cause a program runaway.

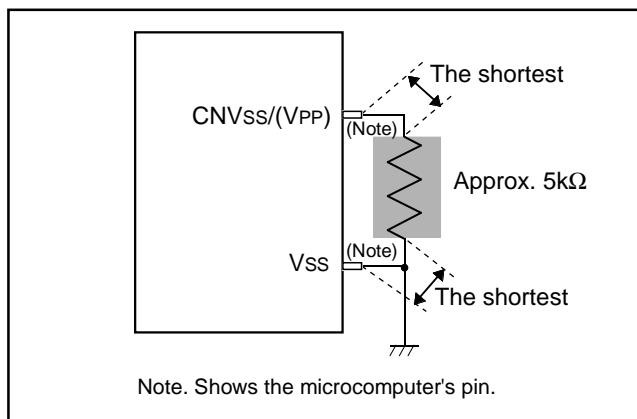

Fig. 7 Wiring for the CNVSS/VPP pin

## Handling of Source Pins

In order to avoid a latch-up occurrence, connect a capacitor suitable for high frequencies as bypass capacitor between power source pin (VCC pin) and GND pin (VSS pin) and between power source pin (VCC pin) and analog power source input pin (AVSS pin). Besides, connect the capacitor to as close as possible. For bypass capacitor which should not be located too far from the pins to be connected, a ceramic capacitor of 0.01  $\mu$ F–0.1  $\mu$ F is recommended.

## Differences among 3850 group (standard), 3850 group (spec. H), and 3850 group (spec. A)

- (1) The absolute maximum ratings of 3850 group (spec. H/A) is smaller than that of 3850 group (standard).
  - Power source voltage  $V_{CC} = 0.3$  to 6.5 V
  - CNVSS input voltage  $V_I = -0.3$  to  $V_{CC} + 0.3$  V
- (2) The oscillation circuit constants of XIN-XOUT, XCIN-XCOUT may be some differences between 3850 group (standard) and 3850 group (spec. H).
- (3) Do not write any data to the reserved area and the reserved bit. (Do not change the contents after reset.)
- (4) Fix bit 3 of the CPU mode register to "1".
- (5) Be sure to perform the termination of unused pins.

REVISION HISTORY

3850 Group (Spec.A) Data Sheet

Rev.	Date	Description	
		Page	Summary
1.00	Jun. 10, 2004	–	First edition issued
2.00	Sep. 01, 2005	1, 4-6 3 5 16 35  38  39 67 68 69  70 71 72 73 80	<p>Package name is revised. 42P4B → PRDP0042BA-A</p> <p>Table 1 Pin description is partly revised.</p> <p>GROUP EXPANSION is revised.</p> <p>Fig. 12 Port block diagram (3) is partly revised.</p> <p>WATCHDOG TIMER is revised.</p> <p>Fig. 38 Structure of Watchdog timer control register is partly revised.</p> <p>CLOCK GENERATING CIRCUIT is partly revised.</p> <p>Oscillation Control (1) Stop mode is partly revised.</p> <p>Fig. 42 Ceramic resonator circuit is partly revised.</p> <p>Note 4 of Fig. 45 is added.</p> <p>Table 15 Absolute maximum ratings is partly revised.</p> <p>Reserved Area, Reserved Bit, CPU Mode Register are added.</p> <p>Differences among 3850 group (standard), 3850 group (spec.H), and 3850 group (spec.A) (3), (4) are deleted.</p> <p>Power Source Voltage is added.</p> <p>Flash Memory Version is revised.</p> <p>DATA REQUIRED FOR MASK ORDERS is partly revised. (<a href="http://www.renesas.com/jp/rom">http://www.renesas.com/jp/rom</a>)(<a href="http://japan.renesas.com/homepage.jsp">http://japan.renesas.com/homepage.jsp</a>)</p> <p>Table 17 Absolute maximum ratings is partly revised.</p> <p>Table 18 Recommended operating conditions (1) is partly revised.</p> <p>Table 19 Recommended operating conditions (2) is partly revised.</p> <p>Table 21 Electrical characteristics (2) is partly revised.</p> <p>PACKAGE OUTLINE 42P4B is revised.</p>
2.10	Nov. 14, 2005	1, 4-6 35 67, 70 69 80 81 to 86	<p>Package name is revised. 42P2R-A/E → PRSP0042GA-B</p> <p>Fig. 38 Block diagram of watchdog timer revised.</p> <p>Table 15, Table 17 Package name is revised. 42P2R-A/E → PRSP0042GA-B</p> <p>Fig. 67 Wiring for the CNVss/VPP pin added.</p> <p>PACKAGE OUTLINE 42P4B is revised.</p> <p>Appendix added.</p>

## RENESAS Technology Corp. Sales Strategic Planning Div. Nippon Bldg., 2-6-2, Ohte-machi, Chiyoda-ku, Tokyo 100-0004, Japan

Keep safety first in your circuit designs!

1. Renesas Technology Corp. puts the maximum effort into making semiconductor products better and more reliable, but there is always the possibility that trouble may occur with them. Trouble with semiconductors may lead to personal injury, fire or property damage. Remember to give due consideration to safety when making your circuit designs, with appropriate measures such as (i) placement of substitutive, auxiliary circuits, (ii) use of nonflammable material or (iii) prevention against any malfunction or mishap.

Notes regarding these materials

1. These materials are intended as a reference to assist our customers in the selection of the Renesas Technology Corp. product best suited to the customer's application; they do not convey any license under any intellectual property rights, or any other rights, belonging to Renesas Technology Corp. or a third party.
2. Renesas Technology Corp. assumes no responsibility for any damage, or infringement of any third-party's rights, originating in the use of any product data, diagrams, charts, programs, algorithms, or circuit application examples contained in these materials.
3. All information contained in these materials, including product data, diagrams, charts, programs and algorithms represents information on products at the time of publication of these materials, and are subject to change by Renesas Technology Corp. without notice due to product improvements or other reasons. It is therefore recommended that customers contact Renesas Technology Corp. or an authorized Renesas Technology Corp. product distributor for the latest product information before purchasing a product listed herein.  
The information described here may contain technical inaccuracies or typographical errors.  
Renesas Technology Corp. assumes no responsibility for any damage, liability, or other loss rising from these inaccuracies or errors.  
Please also pay attention to information published by Renesas Technology Corp. by various means, including the Renesas Technology Corp. Semiconductor home page (<http://www.renesas.com>).
4. When using any or all of the information contained in these materials, including product data, diagrams, charts, programs, and algorithms, please be sure to evaluate all information as a total system before making a final decision on the applicability of the information and products. Renesas Technology Corp. assumes no responsibility for any damage, liability or other loss resulting from the information contained herein.
5. Renesas Technology Corp. semiconductors are not designed or manufactured for use in a device or system that is used under circumstances in which human life is potentially at stake. Please contact Renesas Technology Corp. or an authorized Renesas Technology Corp. product distributor when considering the use of a product contained herein for any specific purposes, such as apparatus or systems for transportation, vehicular, medical, aerospace, nuclear, or undersea repeater use.
6. The prior written approval of Renesas Technology Corp. is necessary to reprint or reproduce in whole or in part these materials.
7. If these products or technologies are subject to the Japanese export control restrictions, they must be exported under a license from the Japanese government and cannot be imported into a country other than the approved destination.  
Any diversion or reexport contrary to the export control laws and regulations of Japan and/or the country of destination is prohibited.
8. Please contact Renesas Technology Corp. for further details on these materials or the products contained therein.



### RENESAS SALES OFFICES

<http://www.renesas.com>

Refer to "<http://www.renesas.com/en/network>" for the latest and detailed information.

#### **Renesas Technology America, Inc.**

450 Holger Way, San Jose, CA 95134-1368, U.S.A  
Tel: <1> (408) 382-7500, Fax: <1> (408) 382-7501

#### **Renesas Technology Europe Limited**

Dukes Meadow, Millboard Road, Bourne End, Buckinghamshire, SL8 5FH, U.K.  
Tel: <44> (1628) 585-100, Fax: <44> (1628) 585-900

#### **Renesas Technology Hong Kong Ltd.**

7th Floor, North Tower, World Finance Centre, Harbour City, 1 Canton Road, Tsimshatsui, Kowloon, Hong Kong  
Tel: <852> 2265-6688, Fax: <852> 2730-6071

#### **Renesas Technology Taiwan Co., Ltd.**

10th Floor, No.99, Fushing North Road, Taipei, Taiwan  
Tel: <886> (2) 2715-2888, Fax: <886> (2) 2713-2999

#### **Renesas Technology (Shanghai) Co., Ltd.**

Unit2607 Ruijing Building, No.205 Maoming Road (S), Shanghai 200020, China  
Tel: <86> (21) 6472-1001, Fax: <86> (21) 6415-2952

#### **Renesas Technology Singapore Pte. Ltd.**

1 Harbour Front Avenue, #06-10, Keppel Bay Tower, Singapore 098632  
Tel: <65> 6213-0200, Fax: <65> 6278-8001

#### **Renesas Technology Korea Co., Ltd.**

Kukje Center Bldg. 18th Fl., 191, 2-ka, Hangang-ro, Yongsan-ku, Seoul 140-702, Korea  
Tel: <82> 2-796-3115, Fax: <82> 2-796-2145

#### **Renesas Technology Malaysia Sdn. Bhd.**

Unit 906, Block B, Menara Amcorp, Amcorp Trade Centre, No.18, Jalan Persiaran Barat, 46050 Petaling Jaya, Selangor Darul Ehsan, Malaysia  
Tel: <603> 7955-9390, Fax: <603> 7955-9510