

enCoRe™ V Low Voltage Microcontroller

Features

- **Powerful Harvard Architecture Processor**
 - M8C processor speeds running up to 24 MHz
 - Low power at high processing speeds
 - Interrupt controller
 - 1.71V to 3.6V operating voltage
 - Temperature range: 0°C to 70°C
- **Flexible On-Chip Memory**
 - Up to 32K Flash program storage
 - 50,000 Erase and write cycles
 - Flexible protection modes
 - Up to 2048 bytes SRAM data storage
 - In-System Serial Programming (ISSP)
- **Complete Development Tools**
 - Free development tool (PSoC Designer™)
 - Full featured, in-circuit emulator and programmer
 - Full speed emulation
 - Complex breakpoint structure
 - 128K trace memory
- **Precision, Programmable Clocking**
 - Crystal-less oscillator with support for an external crystal or resonator
 - Internal ±5.0% 6, 12, or 24 MHz main oscillator
 - Internal low speed oscillator at 32 kHz for watchdog and sleep. The frequency range is 19 to 50 kHz with a 32 kHz typical value
- **Programmable Pin Configurations**
 - 25 mA sink current on all GPIO
 - Pull Up, High Z, Open Drain, CMOS drive modes on all GPIO
 - Configurable inputs on all GPIO
 - Low dropout voltage regulator for Port 1 pins. Programmable to output 3.0, 2.5, or 1.8V at the I/O pins
 - Selectable, regulated digital I/O on Port 1
 - Configurable input threshold for Port 1
 - 3.0V, 20 mA total Port 1 source current
 - Hot-swappable
 - 5 mA strong drive mode on Ports 0 and 1
- **Additional System Resources**
 - Configurable communication speeds
 - I²C Slave
 - Selectable to 50 kHz, 100 kHz, or 400 kHz
 - Implementation requires no clock stretching
 - Implementation during sleep modes with less than 100 mA
 - Hardware address detection
 - SPI master and SPI slave
 - Configurable between 93.75 kHz and 12 MHz
 - Three 16-bit timers
 - 8-bit ADC used to monitor battery voltage or other signals - with external components
 - Watchdog and sleep timers
 - Integrated supervisory circuit

enCoRe V LV Block Diagram

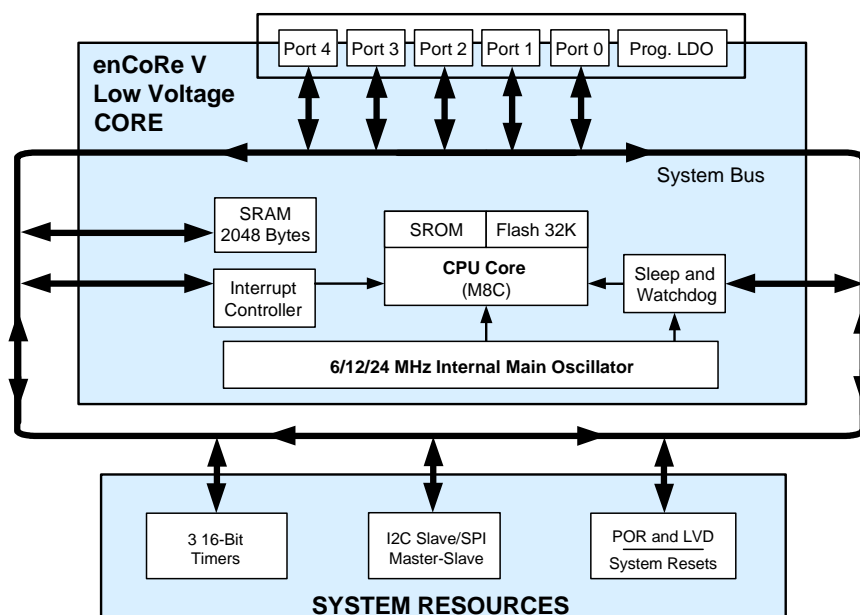

Functional Overview

The enCoRe V LV family of devices are designed to replace multiple traditional low voltage microcontroller system components with one, low cost single chip programmable component. Communication peripherals (I2C/SPI), a fast CPU, Flash program memory, SRAM data memory, and configurable I/O are included in a range of convenient pinouts.

The architecture for this device family, as illustrated in enCoRe V LV Block Diagram, is comprised of two main areas: the CPU core and the system resources. Depending on the enCoRe V LV package, up to 36 general purpose IO (GPIO) are also included.

Enhancements over the Cypress's legacy low voltage microcontrollers include faster CPU at lower voltage operation, lower current consumption, twice the RAM and Flash, hot-swappable I/Os, I2C hardware address recognition, new very low current sleep mode, and new package options.

The enCoRe V LV Core

The enCoRe V LV Core is a powerful engine that supports a rich instruction set. It encompasses SRAM for data storage, an interrupt controller, sleep and watchdog timers, and IMO (internal main oscillator) and ILO (internal low speed oscillator). The CPU core, called the M8C, is a powerful processor with speeds up to 24 MHz. The M8C is a four-MIPS, 8-bit Harvard architecture microprocessor.

System Resources provide additional capability, such as a configurable I²C slave and SPI master-slave communication interface and various system resets supported by the M8C.

Additional System Resources

System Resources, some of which have been previously listed, provide additional capability useful to complete systems. Additional resources include low voltage detection and power on reset. The following statements describe the merits of each system resource:

- 8-bit on-chip ADC shared between System Performance manager (used to calculate parameters based on temperature for flash write operations) and the user.
- The I²C slave and SPI master-slave module provides 50, 100, or 400 kHz communication over two wires. SPI communication over three or four wires runs at speeds of 46.9 kHz to 3 MHz (lower for a slower system clock).
- In I²C slave mode, the hardware address recognition feature reduces the already low power consumption by eliminating the need for CPU intervention until a packet addressed to the target device has been received.
- Low Voltage Detection (LVD) interrupts can signal the application of falling voltage levels, while the advanced POR (Power On Reset) circuit eliminates the need for a system supervisor.
- The 5V maximum input, 1.8, 2.5, or 3V selectable output, low dropout regulator (LDO) provides regulation for I/Os. A register controlled bypass mode enables the user to disable the LDO.
- Standard Cypress PSoC IDE tools are available for debugging the enCoRe V LV family of parts.

Getting Started

The quickest way to understanding the enCoRe V silicon is by reading this data sheet and using the PSoC Designer Integrated Development Environment (IDE). This data sheet is an overview of the enCoRe V integrated circuit and presents specific pin, register, and electrical specifications. For in-depth information, along with detailed programming information, reference the *PSoC Programmable System-on-Chip Technical Reference Manual*, for CY8C28xxx PSoC devices.

For up-to-date Ordering, Packaging, and Electrical Specification information, reference the latest enCoRe V device data sheets on the web at <http://www.cypress.com>.

Development Kits

Development Kits are available online from Cypress at www.cypress.com/shop and through a growing number of regional and global distributors, which include Arrow, Avnet, Digi-Key, Farnell, Future Electronics, and Newark.

Training

Free technical training (on demand, webinars, and workshops) is available online at www.cypress.com/training. The training covers a wide variety of topics and skill levels to assist you in your designs.

CyPros Consultants

Certified PSoC Consultants offer everything from technical assistance to completed PSoC designs. To contact or become a PSoC Consultant go to www.cypress.com/cypros.

Solutions Library

Visit our growing library of solution focused designs at www.cypress.com/solutions. Here you can find various application designs that include firmware and hardware design files that enable you to complete your designs quickly.

Technical Support

For assistance with technical issues, search KnowledgeBase articles and forums at www.cypress.com/support. If you cannot find an answer to your question, call technical support at 1-800-541-4736.

Application Notes

Application notes are an excellent introduction to the wide variety of possible PSoC designs. They are located here: www.cypress.com/psoc. Select Application Notes under the Documentation tab.

Development Tools

PSoC Designer is a Microsoft® Windows-based, integrated development environment for the Programmable System-on-Chip (PSoC) devices. The PSoC Designer IDE runs on Windows XP or Windows Vista.

This system provides design database management by project, an integrated debugger with In-Circuit Emulator, in-system programming support, and built-in support for third-party assemblers and C compilers.

PSoC Designer also supports C language compilers developed specifically for the devices in the enCoRe and PSoC families.

PSoC Designer Software Subsystems

Chip-Level View

The chip-level view is a traditional integrated development environment (IDE) based on PSoC Designer 4.4. Choose a base device to work with and then select different onboard analog and digital components called user modules that use the PSoC blocks. Examples of user modules are ADCs, DACs, Amplifiers, and Filters. Configure the user modules for the chosen application and connect them to each other and to the proper pins. Then generate your project. This prepopulates your project with APIs and libraries that you can use to program your application.

The tool also supports easy development of multiple configurations and dynamic reconfiguration. Dynamic reconfiguration enables changing configurations at run time.

System-Level View

The system-level view is a drag-and-drop visual embedded system design environment based on PSoC Designer.

Hybrid Designs

You can begin in the system-level view, allow it to choose and configure your user modules, routing, and generate code, then switch to the chip-level view to gain complete control over on-chip resources. All views of the project share common code editor, builder, and common debug, emulation, and programming tools.

Code Generation Tools

PSoC Designer supports multiple third-party C compilers and assemblers. The code generation tools work seamlessly within the PSoC Designer interface and have been tested with a full range of debugging tools. The choice is yours.

Assemblers. The assemblers allow assembly code to be merged seamlessly with C code. Link libraries automatically use absolute addressing or are compiled in relative mode, and linked with other software modules to get absolute addressing.

C Language Compilers. C language compilers are available that support the enCoRe and PSoC families of devices. The products allow you to create complete C programs for the PSoC family devices.

The optimizing C compilers provide all the features of C tailored to the PSoC architecture. They come complete with embedded libraries providing port and bus operations, standard keypad and display support, and extended math functionality.

Debugger

PSoC Designer has a debug environment that provides hardware in-circuit emulation, allowing you to test the program in a physical system while providing an internal view of the PSoC device. Debugger commands allow the designer to read and program flash, read and write data memory, read and write I/O registers, read and write CPU registers, set and clear breakpoints, and provide program run, halt, and step control. The debugger also allows the designer to create a trace buffer of registers and memory locations of interest.

Online Help System

The online help system displays online, context-sensitive help for the user. Designed for procedural help and quick reference, each functional subsystem has its own context-sensitive help. This system also provides tutorials and links to FAQs and an Online Support Forum to aid the designer in getting started.

In-Circuit Emulator

A low cost, high functionality ICE (In-Circuit Emulator) is available for development support. This hardware has the capability to program single devices.

The emulator consists of a base unit that connects to the PC by way of a USB port. The base unit is universal and operates with all enCoRe and PSoC devices. Emulation pods for each device family are available separately. The emulation pod takes the place of the PSoC device in the target board and performs full speed (24 MHz) operation.

Designing with PSoC Designer

The development process for the enCoRe V device differs from that of a traditional fixed function microprocessor. Powerful PSoC Designer tools get the core of your design up and running in minutes instead of hours.

The development process can be summarized in the following four steps:

1. Select Components
2. Configure Components
3. Organize and Connect
4. Generate, Verify, and Debug

Select Components

The chip-level views provide a library of pre-built, pre-tested hardware peripheral components. These components are called “user modules.” User modules make selecting and implementing peripheral devices simple, and come in analog, digital, and mixed-signal varieties.

Configure Components

Each of the components you select establishes the basic register settings that implement the selected function. They also provide parameters and properties that allow you to tailor their precise configuration to your particular application.

The chip-level user modules are documented in data sheets that are viewed directly in PSoC Designer. These data sheets explain the internal operation of the component and provide performance specifications. Each data sheet describes the use of each user module parameter and contains other information you may need to successfully implement your design.

Organize and Connect

You build signal chains at the chip level by interconnecting user modules to each other and the I/O pins, or connect system-level inputs, outputs, and communication interfaces to each other with

valuator functions. In the chip-level view, you perform the selection, configuration, and routing so that you have complete control over the use of all on-chip resources.

Generate, Verify, and Debug

When you are ready to test the hardware configuration or move on to developing code for the project, you perform the “Generate Configuration Files” step. This causes PSoC Designer to generate source code that automatically configures the device to your specification and provides the software for the system.

Both system-level and chip-level designs generate software based on your design. The chip-level design provides application programming interfaces (APIs) with high-level functions to control and respond to hardware events at run time and interrupt service routines that you can adapt as needed. The system-level design also generates a C main() program that completely controls the chosen application and contains placeholders for custom code at strategic positions allowing you to further refine the software without disrupting the generated code.

A complete code development environment allows you to develop and customize your applications in C, assembly language, or both.

The last step in the development process takes place inside PSoC Designer’s Debugger (access by clicking the Connect icon). PSoC Designer downloads the HEX image to the In-Circuit Emulator (ICE) where it runs at full speed. PSoC Designer debugging capabilities rival those of systems costing many times more. In addition to traditional single-step, run-to-breakpoint and watch-variable features, the debug interface provides a large trace buffer and allows you to define complex breakpoint events that include monitoring address and data bus values, memory locations and external signals.

Document Conventions

Acronyms Used

The following table lists the acronyms that are used in this document.

Acronym	Description
API	application programming interface
CPU	central processing unit
GPIO	general purpose IO
ICE	in-circuit emulator
ILO	internal low speed oscillator
IMO	internal main oscillator
IO	input/output
LSb	least significant bit
LVD	low voltage detect
MSb	most significant bit
POR	power on reset
PPOR	precision power on reset
PSoC®	Programmable System-on-Chip™
SLIMO	slow IMO
SRAM	static random access memory

Units of Measure

A units of measure table is located in the Electrical Specifications section. [Table 7](#) on page 14 lists all the abbreviations used to measure the enCoRe V LV devices.

Numeric Naming

Hexadecimal numbers are represented with all letters in uppercase with an appended lowercase 'h' (for example, '14h' or '3Ah'). Hexadecimal numbers may also be represented by a '0x' prefix, the C coding convention. Binary numbers have an appended lowercase 'b' (for example, '01010100b' or '01000011b'). Numbers not indicated by an 'h', 'b', or 0x are decimal.

Pin Configuration

16-Pin Part Pinout

Figure 1. CY7C60413 16-Pin enCoRe V LV Device

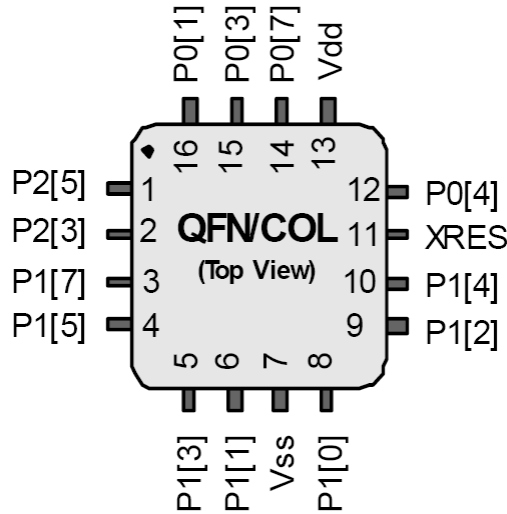

Table 1. 16-Pin Part Pinout (QFN)

Pin No.	Type	Name	Description
1	I/O	P2[5]	Digital I/O, Crystal Out (Xout)
2	I/O	P2[3]	Digital I/O, Crystal In (Xin)
3	IOHR	P1[7]	Digital I/O, I2C SCL, SPI SS
4	IOHR	P1[5]	Digital I/O, I2C SDA, SPI MISO
5	IOHR	P1[3]	Digital I/O, SPI CLK
6	IOHR	P1[1]	Digital I/O, ISSP CLK, I2C SCL, SPI MOSI
7	Power	Vss	Ground Pin
8	IOHR	P1[0]	Digital I/O, ISSP DATA, I2C SDA, SPI CLK
9	IOHR	P1[2]	Digital I/O
10	IOHR	P1[4]	Digital I/O, optional external clock input (EXTCLK)
11	Input	XRES	Active high external reset with internal pull down
12	IOHR	P0[4]	Digital I/O
13	Power	Vdd	Power Pin
14	IOHR	P0[7]	Digital I/O
15	IOHR	P0[3]	Digital I/O
16	IOHR	P0[1]	Digital I/O

LEGEND I = Input, O = Output, OH = 5 mA High Output Drive, R = Regulated Output.

32-Pin Part Pinout

Figure 2. CY7C60445 32-Pin enCoRe V LV Device

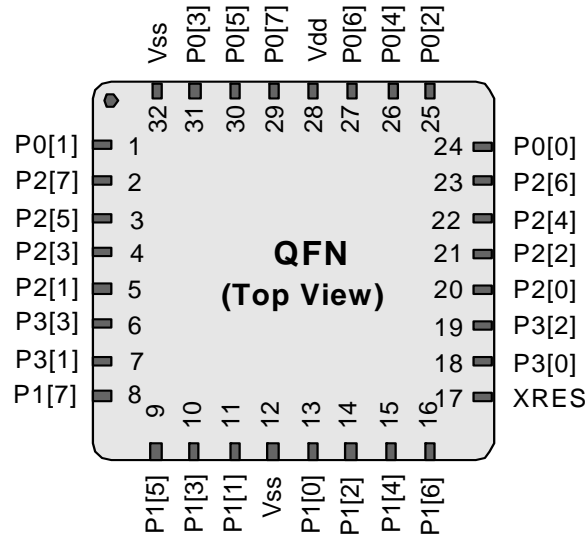

Table 2. 32-Pin Part Pinout (QFN)

Pin No.	Type	Name	Description
1	IOH	P0[1]	Digital I/O
2	I/O	P2[7]	Digital I/O
3	I/O	P2[5]	Digital I/O, Crystal Out (Xout)
4	I/O	P2[3]	Digital I/O, Crystal In (Xin)
5	I/O	P2[1]	Digital I/O
6	I/O	P3[3]	Digital I/O
7	I/O	P3[1]	Digital I/O
8	IOHR	P1[7]	Digital I/O, I2C SCL, SPI SS
9	IOHR	P1[5]	Digital I/O, I2C SDA, SPI MISO
10	IOHR	P1[3]	Digital I/O, SPI CLK
11	IOHR	P1[1] ^(3, 4)	Digital I/O, ISSP CLK, I2C SCL, SPI MOSI
12	Power	Vss	Ground connection
13	IOHR	P1[0] ^(3, 4)	Digital I/O, ISSP DATA, I2C SDA, SPI CLK
14	IOHR	P1[2]	Digital I/O
15	IOHR	P1[4]	Digital I/O, optional external clock input (EXTCLK)
16	IOHR	P1[6]	Digital I/O

Notes

1. During power up or reset event, device P1[0] and P1[1] may disturb the I2C bus. Use alternate pins if issues are encountered.
2. These are the in-system serial programming (ISSP) pins, that are not High Z at power on reset (POR)

Table 2. 32-Pin Part Pinout (QFN) (continued)

Pin No.	Type	Name	Description
17	Reset Input	XRES	Active high external reset with internal pull down
18	I/O	P3[0]	Digital I/O
19	I/O	P3[2]	Digital I/O
20	I/O	P2[0]	Digital I/O
21	I/O	P2[2]	Digital I/O
22	I/O	P2[4]	Digital I/O
23	I/O	P2[6]	Digital I/O
24	IOH	P0[0]	Digital I/O
25	IOH	P0[2]	Digital I/O
26	IOH	P0[4]	Digital I/O
27	IOH	P0[6]	Digital I/O
28	Power	Vdd	Supply voltage
29	IOH	P0[7]	Digital I/O
30	IOH	P0[5]	Digital I/O
31	IOH	P0[3]	Digital I/O
32	Power	Vss	Ground connection
CP	Power	Vss	Center pad must be connected to ground

LEGEND I = Input, O = Output, OH = 5 mA High Output Drive, R = Regulated Output.

Notes

3. During power up or reset event, device P1[0] and P1[1] may disturb the I2C bus. Use alternate pins if issues are encountered.
4. These are the in-system serial programming (ISSP) pins, that are not High Z at power on reset (POR)

48-Pin Part Pinout

Figure 3. CY7C60455/CY7C60456 48-Pin enCoRe V LV Device

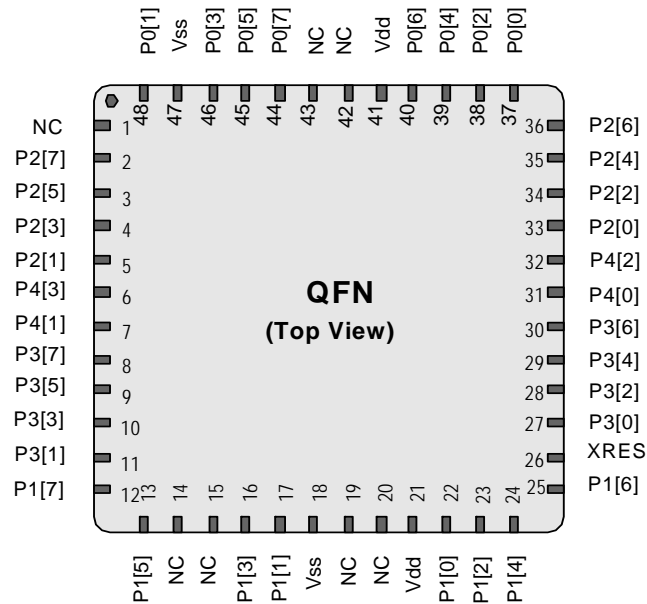

Table 3. 48-Pin Part Pinout (QFN)

Pin No.	Type	Name	Description
1	NC	NC	No connection
2	I/O	P2[7]	Digital I/O
3	I/O	P2[5]	Digital I/O, Crystal Out (Xout)
4	I/O	P2[3]	Digital I/O, Crystal In (Xin)
5	I/O	P2[1]	Digital I/O
6	I/O	P4[3]	Digital I/O
7	I/O	P4[1]	Digital I/O
8	I/O	P3[7]	Digital I/O
9	I/O	P3[5]	Digital I/O
10	I/O	P3[3]	Digital I/O
11	I/O	P3[1]	Digital I/O
12	IOHR	P1[7]	Digital I/O, I2C SCL, SPI SS
13	IOHR	P1[5]	Digital I/O, I2C SDA, SPI MISO
14	NC	NC	No connection
15	NC	NC	No connection
16	IOHR	P1[3]	Digital I/O, SPI CLK
17	IOHR	P1[1] ^(3, 4)	Digital I/O, ISSP CLK, I2C SCL, SPI MOSI

Table 3. 48-Pin Part Pinout (QFN) (continued)

Pin No.	Type	Name	Description
18	Power	Vss	Supply ground
19	NC	NC	No connection
20	NC	NC	No connection
21	Power	Vdd	Supply voltage
22	IOHR	P1[0] ^(3, 4)	Digital I/O, ISSP DATA, I2C SDA, SPI CLK
23	IOHR	P1[2]	Digital I/O
24	IOHR	P1[4]	Digital I/O, optional external clock input (EXTCLK)
25	IOHR	P1[6]	Digital I/O
26	XRES	Ext Reset	Active high external reset with internal pull down
27	I/O	P3[0]	Digital I/O
28	I/O	P3[2]	Digital I/O
29	I/O	P3[4]	Digital I/O
30	I/O	P3[6]	Digital I/O
31	I/O	P4[0]	Digital I/O
32	I/O	P4[2]	Digital I/O
33	I/O	P2[0]	Digital I/O
34	I/O	P2[2]	Digital I/O
35	I/O	P2[4]	Digital I/O
36	I/O	P2[6]	Digital I/O
37	IOH	P0[0]	Digital I/O
38	IOH	P0[2]	Digital I/O
39	IOH	P0[4]	Digital I/O
40	IOH	P0[6]	Digital I/O
41	Power	Vdd	Supply voltage
42	NC	NC	No connection
43	NC	NC	No connection
44	IOH	P0[7]	Digital I/O
45	IOH	P0[5]	Digital I/O
46	IOH	P0[3]	Digital I/O
47	Power	Vss	Supply ground
48	IOH	P0[1]	Digital I/O
CP	Power	Vss	Center pad must be connected to ground

LEGEND I = Input, O = Output, OH = 5 mA High Output Drive, R = Regulated Output

Register Reference

The section discusses the registers of the enCoRe V LV device. It lists all the registers in mapping tables, in address order.

Register Conventions

The register conventions specific to this section are listed in the following table.

Table 4. Register Conventions

Convention	Description
R	Read register or bits
W	Write register or bits
L	Logical register or bits
C	Clearable register or bits
#	Access is bit specific

Register Mapping Tables

The enCoRe V LV device has a total register address space of 512 bytes. The register space is also referred to as IO space and is broken into two parts: Bank 0 (user space) and Bank 1 (configuration space). The XIO bit in the Flag register (CPU_F) determines which bank the user is currently in. When the XIO bit is set, the user is said to be in the “extended” address space or the “configuration” registers.

Table 5. Register Map Bank 0 Table: User Space

Name	Addr (0,Hex)	Access	Name	Addr (0,Hex)	Access	Name	Addr (0,Hex)	Access	Name	Addr (0,Hex)	Access
PRT0DR	00	RW		40			80			C0	
PRT0IE	01	RW		41			81			C1	
	02			42			82			C2	
	03			43			83			C3	
PRT1DR	04	RW		44			84			C4	
PRT1IE	05	RW		45			85			C5	
	06			46			86			C6	
	07			47			87			C7	
PRT2DR	08	RW		48			88		I2C_XCFG	C8	RW
PRT2IE	09	RW		49			89		I2C_XSTAT	C9	R
	0A			4A			8A		I2C_ADDR	CA	RW
	0B			4B			8B		I2C_BP	CB	R
PRT3DR	0C	RW		4C			8C		I2C_CP	CC	R
PRT3IE	0D	RW		4D			8D		CPU_BP	CD	RW
	0E			4E			8E		CPU_CP	CE	R
	0F			4F			8F		I2C_BUF	CF	RW
PRT4DR	10	RW		50			90		CUR_PP	D0	RW
PRT4IE	11	RW		51			91		STK_PP	D1	RW
	12			52			92			D2	
	13			53			93		IDX_PP	D3	RW
	14			54			94		MVR_PP	D4	RW
	15			55			95		MVW_PP	D5	RW
	16			56			96		I2C_CFG	D6	RW
	17			57			97		I2C_SCR	D7	#
	18			58			98		I2C_DR	D8	RW
	19			59			99			D9	
	1A			5A			9A		INT_CLR0	DA	RW
	1B			5B			9B		INT_CLR1	DB	RW
	1C			5C			9C		INT_CLR2	DC	RW
	1D			5D			9D		INT_CLR3	DD	RW
	1E			5E			9E		INT_MSK2	DE	RW
	1F			5F			9F		INT_MSK1	DF	RW
	20			60			A0		INT_MSK0	E0	RW
	21			61			A1		INT_SW_EN	E1	RW
	22			62			A2		INT_VC	E2	RC
	23			63			A3		RES_WDT	E3	W
	24			64			A4		INT_MSK3	E4	RW
	25			65			A5			E5	
	26			66			A6			E6	
	27			67			A7			E7	
	28			68			A8			E8	
SPI_TXR	29	W		69			A9			E9	
SPI_RXR	2A	R		6A			AA			EA	
SPI_CR	2B	#		6B			AB			EB	
	2C			6C			AC			EC	
	2D			6D			AD			ED	
	2E			6E			AE			EE	
	2F			6F			AF			EF	
	30			70		PT0_CFG	B0	RW		F0	
	31			71		PT0_DATA1	B1	RW		F1	
	32			72		PT0_DATA0	B2	RW		F2	
	33			73		PT1_CFG	B3	RW		F3	
	34			74		PT1_DATA1	B4	RW		F4	
	35			75		PT1_DATA0	B5	RW		F5	
	36			76		PT2_CFG	B6	RW		F6	
	37			77		PT2_DATA1	B7	RW	CPU_F	F7	RL
	38			78		PT2_DATA0	B8	RW		F8	
	39			79			B9			F9	
	3A			7A			BA			FA	
	3B			7B			BB			FB	
	3C			7C			BC			FC	
	3D			7D			BD			FD	
	3E			7E			BE		CPU_SCR1	FE	#
	3F			7F			BF		CPU_SCR0	FF	#

Gray fields are reserved and should not be accessed. # Access is bit specific.

Table 6. Register Map Bank 1 Table: Configuration Space

Name	Addr (1,Hex)	Access	Name	Addr (1,Hex)	Access	Name	Addr (1,Hex)	Access	Name	Addr (1,Hex)	Access
PRT0DM0	00	RW		40			80			C0	
PRT0DM1	01	RW		41			81			C1	
	02			42			82			C2	
	03			43			83			C3	
PRT1DM0	04	RW		44			84			C4	
PRT1DM1	05	RW		45			85			C5	
	06			46			86			C6	
	07			47			87			C7	
PRT2DM0	08	RW		48			88			C8	
PRT2DM1	09	RW		49			89			C9	
	0A			4A			8A			CA	
	0B			4B			8B			CB	
PRT3DM0	0C	RW		4C			8C			CC	
PRT3DM1	0D	RW		4D			8D			CD	
	0E			4E			8E			CE	
	0F			4F			8F			CF	
PRT4DM0	10	RW		50			90			D0	
PRT4DM1	11	RW		51			91			D1	
	12			52			92			D2	
	13			53			93			D3	
	14			54			94			D4	
	15			55			95			D5	
	16			56			96			D6	
	17			57			97			D7	
	18			58			98			D8	
	19			59			99			D9	
	1A			5A			9A			DA	
	1B			5B			9B			DB	
	1C			5C			9C		IO_CFG	DC	RW
	1D			5D			9D		OUT_P1	DD	RW
	1E			5E			9E			DE	
	1F			5F			9F			DF	
	20			60			A0		OSC_CR0	E0	RW
	21			61			A1		ECO_CFG	E1	#
	22			62			A2		OSC_CR2	E2	RW
	23			63			A3		VLT_CR	E3	RW
	24			64			A4		VLT_CMP	E4	R
	25			65			A5			E5	
	26			66			A6			E6	
	27			67			A7			E7	
	28			68			A8		IMO_TR	E8	W
SPI_CFG	29	RW		69			A9		ILO_TR	E9	W
	2A			6A			AA			EA	
	2B			6B			AB		SLP_CFG	EB	RW
	2C		TMP_DR0	6C	RW		AC		SLP_CFG2	EC	RW
	2D		TMP_DR1	6D	RW		AD		SLP_CFG3	ED	RW
	2E		TMP_DR2	6E	RW		AE			EE	
	2F		TMP_DR3	6F	RW		AF			EF	
	30			70			B0			F0	
	31			71			B1			F1	
	32			72			B2			F2	
	33			73			B3			F3	
	34			74			B4			F4	
	35			75			B5			F5	
	36			76			B6			F6	
	37			77			B7		CPU_F	F7	RL
	38			78			B8			F8	
	39			79			B9			F9	
	3A			7A			BA			FA	
	3B			7B			BB			FB	
	3C			7C			BC			FC	
	3D			7D			BD			FD	
	3E			7E			BE			FE	
	3F			7F			BF			FF	

Gray fields are reserved and should not be accessed. # Access is bit specific.

Electrical Specifications

This section presents the DC and AC electrical specifications of the enCoRe V LV devices. For the most up to date electrical specifications, verify that you have the most recent data sheet available by visiting the company web site at <http://www.cypress.com>.

Figure 4. Voltage versus CPU Frequency

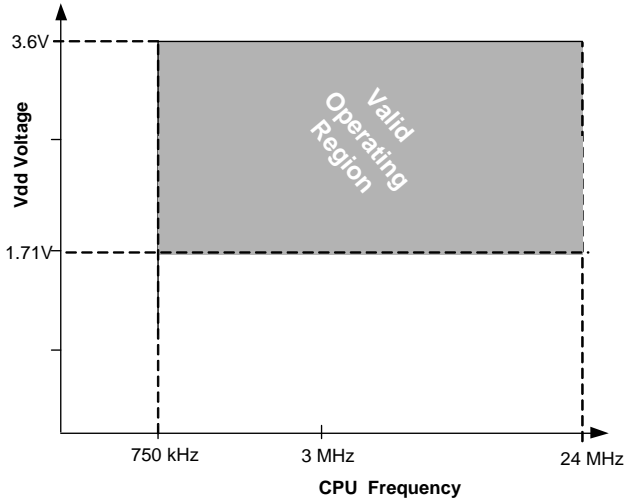
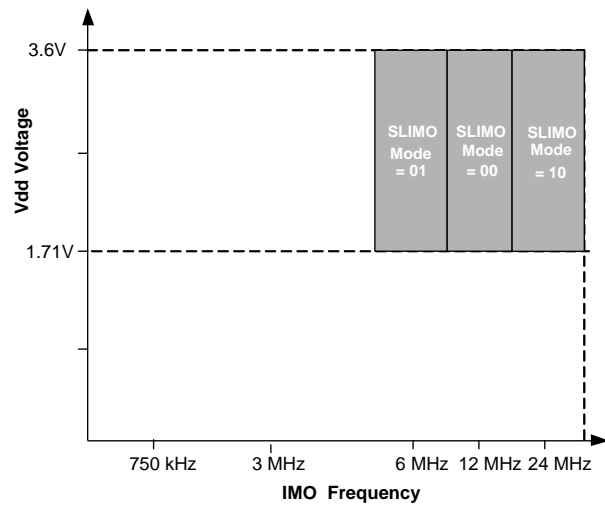

Figure 5. IMO Frequency Trim Options



The following table lists the units of measure that are used in this chapter.

Table 7. Units of Measure

Symbol	Unit of Measure	Symbol	Unit of Measure
°C	degree Celsius	μW	microwatts
dB	decibels	mA	milli-ampere
fF	femto farad	ms	milli-second
Hz	hertz	mV	milli-volts
KB	1024 bytes	nA	nanoampere
Kbit	1024 bits	ns	nanosecond
kHz	kilohertz	nV	nanovolts
kΩ	kilohm	Ω	ohm
MHz	megahertz	pA	picoampere
MΩ	megaohm	pF	picofarad
μA	microampere	pp	peak-to-peak
μF	microfarad	ppm	parts per million
μH	microhenry	ps	picosecond
μs	microsecond	sps	samples per second
μV	microvolts	s	sigma: one standard deviation
μVrms	microvolts root-mean-square	V	volts

ADC Electrical Specifications
Table 8. ADC Electrical Specifications

Symbol	Description	Min	Typ	Max	Units	Conditions
	Input					
	Input Voltage Range	V _{ss}		1.3	V	This gives 72% of maximum code
	Input Capacitance			5	pF	
	Resolution		8		Bits	
	8-Bit Sample Rate		23.4375		ksps	Data Clock set to 6 MHz. Sample Rate = $0.001/(2^{\text{Resolution}}/\text{Data clock})$
	DC Accuracy					
	DNL	-1		+2	LSb	For any configuration
	INL	-2		+2	LSb	For any configuration
	Offset Error	0	15	90	mV	
	Operating Current		275	350	μA	
	Data Clock	2.25		12	MHz	Source is chip's internal main oscillator. See AC Chip Level Specifications for accuracy.
	Monotonicity					Not guaranteed. See DNL
	Power Supply Rejection Ratio					
	PSRR (V _{dd} >3.0V)		24		dB	
	PSRR (2.2 < V _{dd} < 3.0)		30		dB	
	PSRR (2.0 < V _{dd} < 2.2)		12		dB	
	PSRR (V _{dd} < 2.0)		0		dB	
	Gain Error	1		5	%FSR	For any resolution
	Input Resistance	$1/(500\text{fF} \cdot \text{Data-Clock})$	$1/(400\text{fF} \cdot \text{Data-Clock})$	$1/(300\text{fF} \cdot \text{Data-Clock})$	Ω	Equivalent switched cap input resistance for 8-, 9-, or 10-bit resolution.

Maximum Ratings

Storage Temperature (T_{STG})⁽⁵⁾ -55°C to 125°C (Typical +25°C)
 Supply Voltage Relative to Vss (Vdd)..... -0.5V to +4.0V
 DC Input Voltage (V_{IO})..... Vss - 0.5V to Vdd + 0.5V
 DC Voltage Applied to Tri-state (V_{IOZ})Vss - 0.5V to Vdd + 0.5V
 Maximum Current into any Port Pin (I_{MIO}). -25mA to +50 mA

Electro Static Discharge Voltage (ESD)⁽⁶⁾ 2000V
 Latch-up Current (LU)⁽⁷⁾ 200 mA

Operating Conditions

Ambient Temperature (T_A) 0°C to 70°C
 Operational Die Temperature (T_J)⁽⁸⁾ 0°C to 85°C

DC Electrical Characteristics

DC Chip Level Specifications

Table 9 lists guaranteed maximum and minimum specifications for the entire voltage and temperature ranges.

Table 9. DC Chip Level Specifications

Parameter	Description	Conditions	Min	Typ	Max	Units
Vdd	Supply Voltage	See table titled DC POR and LVD Specifications on page 20 .	1.71	–	3.6	V
I _{DD24}	Supply Current, IMO = 24 MHz	Conditions are Vdd = 3.0V, T _A = 25°C, CPU = 24 MHz No I2C/SPI	–	–	3.1	mA
I _{DD12}	Supply Current, IMO = 12 MHz	Conditions are Vdd = 3.0V, T _A = 25°C, CPU = 12 MHz No I2C/SPI	–	–	2.0	mA
I _{DD6}	Supply Current, IMO = 6 MHz	Conditions are Vdd = 3.0V, T _A = 25°C, CPU = 6 MHz No I2C/SPI	–	–	1.5	mA
I _{SB0}	Deep Sleep Current	Vdd = 3.0V, T _A = 25°C, IO regulator turned off	–	0.1	–	µA
I _{SB1}	Standby Current with POR, LVD, and Sleep Timer	Vdd = 3.0V, T _A = 25°C, IO regulator turned off	–	–	1.5	µA

Notes

- Higher storage temperatures reduce data retention time. Recommended storage temperature is +25°C ± 25°C. Extended duration storage temperatures above 85°C degrade reliability.
- Human Body Model ESD.
- According to JESD78 standard.
- The temperature rise from ambient to junction is package specific. See [on page 27](#). The user must limit the power consumption to comply with this requirement.

DC General Purpose I/O Specifications

The following tables list guaranteed maximum and minimum specifications for the voltage and temperature ranges: 1.71V to 3.6V and 0°C ≤ T_A ≤ 70°C. Typical parameters apply to 3.3V at 25°C. These are for design guidance only.

Table 10. 3.0V to 3.6V DC GPIO Specifications

Symbol	Description	Conditions	Min	Typ	Max	Units
R _{PU}	Pull Up Resistor		4	5.6	8	kΩ
V _{OH1}	High Output Voltage Port 2 or 3 Pins	I _{OH} ≤ 10 μA, maximum of 10 mA source current in all I/Os	V _{dd} - 0.2	–	–	V
V _{OH2}	High Output Voltage Port 2 or 3 Pins	I _{OH} = 1 mA, maximum of 20 mA source current in all I/Os	V _{dd} - 0.9	–	–	V
V _{OH3}	High Output Voltage Port 0 or 1 Pins with LDO Regulator Disabled for Port 1	I _{OH} < 10 μA, maximum of 10 mA source current in all I/Os	V _{dd} - 0.2	–	–	V
V _{OH4}	High Output Voltage Port 0 or 1 Pins with LDO Regulator Disabled for Port 1	I _{OH} = 5 mA, maximum of 20 mA source current in all I/Os	V _{dd} - 0.9	–	–	V
V _{OH5}	High Output Voltage Port 1 Pins with LDO Regulator Enabled for 3V Out	I _{OH} < 10 μA, V _{dd} > 3.1V, maximum of 4 I/Os all sourcing 5 mA	2.85	3.00	3.3	V
V _{OH6}	High Output Voltage Port 1 Pins with LDO Regulator Enabled for 3V Out	I _{OH} = 5 mA, V _{dd} > 3.1V, maximum of 20 mA source current in all I/Os	2.20	–	–	V
V _{OH7}	High Output Voltage Port 1 Pins with LDO Enabled for 2.5V Out	I _{OH} < 10 μA, V _{dd} > 2.7V, maximum of 20 mA source current in all I/Os	2.35	2.50	2.75	V
V _{OH8}	High Output Voltage Port 1 Pins with LDO Enabled for 2.5V Out	I _{OH} = 2 mA, V _{dd} > 2.7V, maximum of 20 mA source current in all I/Os	1.90	–	–	V
V _{OH9}	High Output Voltage Port 1 Pins with LDO Enabled for 1.8V Out	I _{OH} < 10 μA, V _{dd} > 2.7V, maximum of 20 mA source current in all I/Os	1.60	1.80	2.1	V
V _{OH10}	High Output Voltage Port 1 Pins with LDO Enabled for 1.8V Out	I _{OH} = 1 mA, V _{dd} > 2.7V, maximum of 20 mA source current in all I/Os	1.20	–	–	V
V _{OL}	Low Output Voltage	I _{OL} = 25 mA, V _{dd} > 3.3V, maximum of 60 mA sink current on even port pins (for example, P0[2] and P1[4]) and 60 mA sink current on odd port pins (for example, P0[3] and P1[5])	–	–	0.75	V
V _{IL}	Input Low Voltage		–	–	0.80	V
V _{IH}	Input High Voltage		2.00	–	–	V
V _H	Input Hysteresis Voltage		–	80	–	mV
I _{IL}	Input Leakage (Absolute Value)		–	0.001	1	μA
C _{PIN}	Pin Capacitance	Package and pin dependent Temp = 25°C	0.5	1.7	5	pF

Table 11. 2.4V to 3.0V DC GPIO Specifications

Symbol	Description	Conditions	Min	Typ	Max	Units
R _{PU}	Pull Up Resistor		4	5.6	8	kΩ
V _{OH1}	High Output Voltage Port 2 or 3 Pins	IOH < 10 μA, maximum of 10 mA source current in all I/Os	Vdd - 0.2	–	–	V
V _{OH2}	High Output Voltage Port 2 or 3 Pins	IOH = 0.2 mA, maximum of 10 mA source current in all I/Os	Vdd - 0.4	–	–	V
V _{OH3}	High Output Voltage Port 0 or 1 Pins with LDO Regulator Disabled for Port 1	IOH < 10 μA, maximum of 10 mA source current in all I/Os	Vdd - 0.2	–	–	V
V _{OH4}	High Output Voltage Port 0 or 1 Pins with LDO Regulator Disabled for Port 1	IOH = 2 mA, maximum of 10 mA source current in all I/Os	Vdd - 0.5	–	–	V
V _{OH5A}	High Output Voltage Port 1 Pins with LDO Enabled for 1.8V Out	IOH < 10 μA, Vdd > 2.4V, maximum of 20 mA source current in all I/Os.	1.50	1.80	2.10	V
V _{OH6A}	High Output Voltage Port 1 Pins with LDO Enabled for 1.8V Out	IOH = 1 mA, Vdd > 2.4V, maximum of 20 mA source current in all I/Os	1.20	–	–	V
V _{OL}	Low Output Voltage	IOL = 10 mA, maximum of 30 mA sink current on even port pins (for example, P0[2] and P1[4]) and 30 mA sink current on odd port pins (for example, P0[3] and P1[5])	–	–	0.75	V
V _{IL}	Input Low Voltage		–	–	0.72	V
V _{IH}	Input High Voltage		1.6	–	–	V
V _H	Input Hysteresis Voltage		–	80	–	mV
I _{IL}	Input Leakage (Absolute Value)		–	0.001	1	μA
C _{PIN}	Capacitive Load on Pins	Package and pin dependent Temp = 25°C	0.5	1.7	5	pF

Table 12. 1.71V to 2.4V DC GPIO Specifications

Symbol	Description	Conditions	Min	Typ	Max	Units
R _{PU}	Pull Up Resistor		4	5.6	8	kΩ
V _{OH1}	High Output Voltage Port 2 or 3 Pins	I _{OH} = 10 μA, maximum of 10 mA source current in all I/Os	V _{dd} - 0.2	–	–	V
V _{OH2}	High Output Voltage Port 2 or 3 Pins	I _{OH} = 0.5 mA, maximum of 10 mA source current in all I/Os	V _{dd} - 0.5	–	–	V
V _{OH3}	High Output Voltage Port 0 or 1 Pins with LDO Regulator Disabled for Port 1	I _{OH} = 100 μA, maximum of 10 mA source current in all I/Os	V _{dd} - 0.2	–	–	V
V _{OH4}	High Output Voltage Port 0 or 1 Pins with LDO Regulator Disabled for Port 1	I _{OH} = 2 mA, maximum of 10 mA source current in all I/Os	V _{dd} - 0.5	–	–	V
V _{OL}	Low Output Voltage	I _{OL} = 5 mA, maximum of 20 mA sink current on even port pins (for example, P0[2] and P1[4]) and 30 mA sink current on odd port pins (for example, P0[3] and P1[5])	–	–	0.4	V
V _{IL}	Input Low Voltage		–	–	0.3 x V _{dd}	V
V _{IH}	Input High Voltage		0.65 x V _{dd}	–	–	V
V _H	Input Hysteresis Voltage		–	80	–	mV
I _{IL}	Input Leakage (Absolute Value)		–	0.001	1	μA
C _{PIN}	Capacitive Load on Pins	Package and pin dependent. Temp = 25°C	0.5	1.7	5	pF

DC POR and LVD Specifications

Table 13 lists guaranteed maximum and minimum specifications for the entire voltage and temperature ranges.

Table 13. DC POR and LVD Specifications

Symbol	Description	Min	Typ	Max	Units
V _{PPOR0}	Vdd Value for PPOR Trip ⁽⁹⁾ PORLEV[1:0] = 00b, HPOR = 0	1.61	1.66	1.71	V
V _{PPOR1}	PORLEV[1:0] = 00b, HPOR = 1		2.36	2.41	V
V _{PPOR2}	PORLEV[1:0] = 01b, HPOR = 1		2.60	2.66	V
V _{PPOR3}	PORLEV[1:0] = 10b, HPOR = 1		2.82	2.95	V
V _{LVD0}	Vdd Value for LVD Trip VM[2:0] = 000b ⁽¹⁰⁾	2.40	2.45	2.51	V
V _{LVD1}	VM[2:0] = 001b ⁽¹¹⁾	2.64	2.71	2.78	V
V _{LVD2}	VM[2:0] = 010b ⁽¹²⁾	2.85	2.92	2.99	V
V _{LVD3}	VM[2:0] = 011b	2.95	3.02	3.09	V
V _{LVD4}	VM[2:0] = 100b	3.06	3.13	3.20	
V _{LVD5}	VM[2:0] = 101b	1.84	1.9	2.32	
V _{LVD6}	VM[2:0] = 110b ⁽¹³⁾	1.75	1.8	1.84	

DC Programming Specifications

Table 14 lists guaranteed maximum and minimum specifications for the entire voltage and temperature ranges.

Table 14. DC Programming Specifications

Symbol	Description	Min	Typ	Max	Units
V _{ddIWRITE}	Supply Voltage for Flash Write Operations	1.71	–	–	V
I _{DDP}	Supply Current During Programming or Verify	–	5	25	mA
V _{ILP}	Input Low Voltage During Programming or Verify	–	–	V _{IL}	V
V _{IHP}	Input High Voltage During Programming or Verify	V _{IH}	–	–	V
I _{ILP}	Input Current when Applying V _{ilp} to P1[0] or P1[1] During Programming or Verify ⁽¹⁴⁾	–	–	0.2	mA
I _{IHP}	Input Current when Applying V _{ihp} to P1[0] or P1[1] During Programming or Verify ⁽¹⁴⁾	–	–	1.5	mA
V _{OLV}	Output Low Voltage During Programming or Verify	–	–	V _{ss} + 0.75	V
V _{OHV}	Output High Voltage During Programming or Verify	V _{OH} ⁽¹³⁾	–	V _{dd}	V
Flash _{ENPB}	Flash Write Endurance ⁽¹⁶⁾	50,000	–	–	Cycles
Flash _{DR}	Flash Data Retention ⁽¹⁷⁾	10	20	–	Years

Notes

9. V_{dd} must be greater than or equal to 1.71V during startup, reset from the XRES pin, or reset from watchdog.
10. Always greater than 50 mV above V_{PPOR1} for falling supply.
11. Always greater than 50 mV above V_{PPOR2} for falling supply.
12. Always greater than 50 mV above V_{PPOR3} for falling supply.
13. Always greater than 50 mV above V_{PPOR0} voltage for falling supply.
14. Driving internal pull down resistor.
15. See appropriate [DC General Purpose I/O Specifications](#) table. For V_{dd} > 3V use V_{OH4} in [Table 10 on page 17](#)
16. Erase/write cycles per block.
17. Following maximum Flash write cycles at Tamb = 55C and Tj = 70C.

AC Electrical Characteristics

AC Chip Level Specifications

Table 15 lists guaranteed maximum and minimum specifications for the entire voltage and temperature ranges.

Table 15. AC Chip Level Specifications

Symbol	Description	Min	Typ	Max	Units
F _{MAX}	Maximum Operating Frequency ⁽¹⁸⁾	24	–	–	MHz
F _{CPU}	Maximum Processing Frequency ⁽¹⁹⁾	24	–	–	MHz
F _{32K1}	Internal Low Speed Oscillator Frequency	19	32	50	kHz
F _{IMO24}	Internal Main Oscillator Stability for 24 MHz ± 5% ⁽²⁰⁾	22.8	24	25.2	MHz
F _{IMO12}	Internal Main Oscillator Stability for 12 MHz ⁽²⁰⁾	11.4	12	12.6	MHz
F _{IMO6}	Internal Main Oscillator Stability for 6 MHz ⁽²⁰⁾	5.7	6.0	6.3	MHz
DC _{IMO}	Duty Cycle of IMO	40	50	60	%
T _{RAMP}	Supply Ramp Time	0	–	–	μs

AC General Purpose IO Specifications

Table 16 lists guaranteed maximum and minimum specifications for the entire voltage and temperature ranges.

Table 16. AC GPIO Specifications

Symbol	Description	Conditions	Min	Typ	Max	Units
F _{GPIO}	GPIO Operating Frequency	Normal Strong Mode, Port 0, 1	0	–	6 MHz for 1.71V<Vdd<2.4V	MHz
			0	–	12 MHz for 2.4V<Vdd<3.6V	
		Normal Strong Mode, Port 2, 3	0	–	3 MHz for 1.71V<Vdd<2.4V 6 MHz for 3.0V<Vdd<3.6V	MHz
TRise23	Rise Time, Strong Mode, Cloud = 50 pF Ports 2 or 3	Vdd = 3.0 to 3.6V, 10% – 90%	15	–	80	ns
		Vdd = 2.4 to 3.0V, 10% – 90%	15	–	100	
TRise23L	Rise Time, Strong Mode Low Supply, Cloud = 50 pF Ports 2 or 3	Vdd = 1.71 to 3.0V, 10% – 90%	15	–	100	ns
TRise01	Rise Time, Strong Mode, Cloud = 50 pF Ports 0 or 1	Vdd = 3.0 to 3.6V, 10% – 90% LDO enabled or disabled	10	–	50	ns
		Vdd = 2.4 to 3.0V, 10% – 90% LDO enabled or disabled	10	–	70	
TRise01L	Rise Time, Strong Mode Low Supply, Cloud = 50 pF Ports 0 or 1	Vdd = 1.71 to 3.0V, 10% – 90% LDO enabled or disabled	15	–	100	ns
TFall	Fall Time, Strong Mode, Cloud = 50 pF All Ports	Vdd = 3.0 to 3.6V, 10% – 90%	10	–	80	ns
		Vdd = 1.71 to 3.0V, 10% - 90%	10	–	80	

Notes

- 18. Digital clocking functions.
- 19. CPU speed.
- 20. Trimmed using factory trim values.

Figure 6. GPIO Timing Diagram

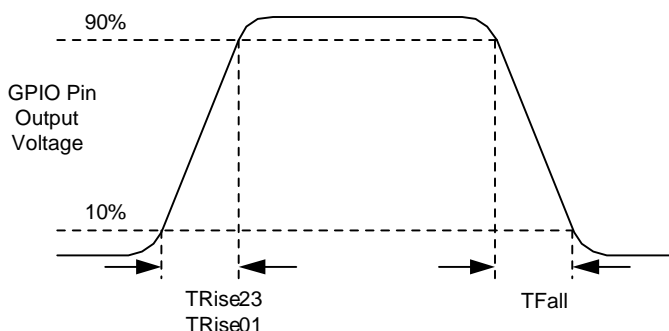

AC External Clock Specifications

Table 17 lists guaranteed maximum and minimum specifications for the entire voltage and temperature ranges.

Table 17. AC External Clock Specifications

Symbol	Description	Min	Typ	Max	Units
F _{OSCEXT}	Frequency	0.750	–	25.2	MHz
–	High Period	20.6	–	5300	ns
–	Low Period	20.6	–	–	ns
–	Power Up IMO to Switch	150	–	–	µs

AC Programming Specifications

Table 18 lists guaranteed maximum and minimum specifications for the entire voltage and temperature ranges.

Table 18. AC Programming Specifications

Symbol	Description	Min	Typ	Max	Units
T _{RSCLK}	Rise Time of SCLK	1	–	20	ns
T _{FSCLK}	Fall Time of SCLK	1	–	20	ns
T _{SSCLK}	Data Set up Time to Falling Edge of SCLK	40	–	–	ns
T _{HSCLK}	Data Hold Time from Falling Edge of SCLK	40	–	–	ns
F _{SCLK}	Frequency of SCLK	0	–	8	MHz
T _{ERASEB}	Flash Erase Time (Block)	–	–	18	ms
T _{WRITE}	Flash Block Write Time	–	–	25	ms
T _{DSCLK1}	Data Out Delay from Falling Edge of SCLK, 3.0V < V _{dd} < 3.6V	–	–	85	ns
T _{DSCLK2}	Data Out Delay from Falling Edge of SCLK, 1.71V < V _{dd} < 3.0V	–	–	130	ns

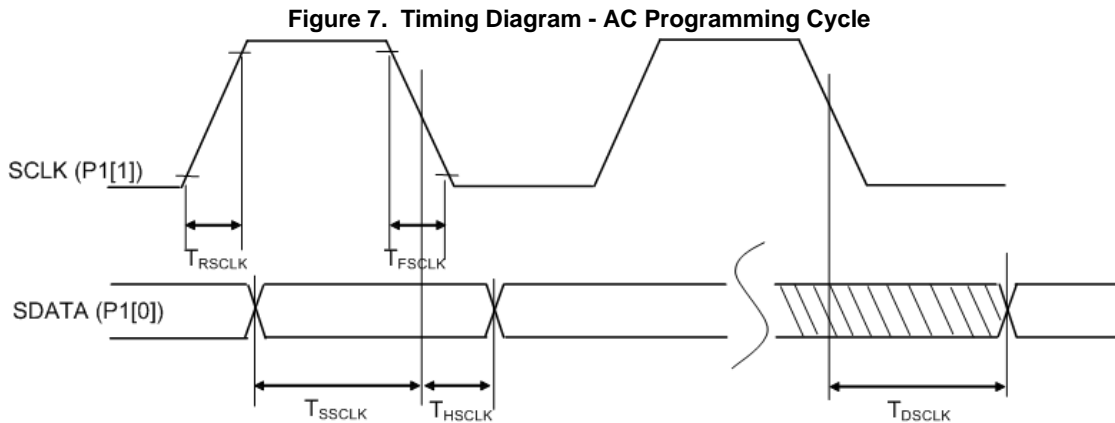

AC SPI Specifications

Table 19 lists guaranteed maximum and minimum specifications for the entire voltage and temperature ranges.

Table 19. AC SPI Specifications

Symbol	Description	Min	Typ	Max	Units
F _{SPI M}	Maximum Input Clock Frequency Selection, Master ⁽²¹⁾ 2.4V < V _{dd} < 3.6V	-	-	12	MHz
	Maximum Input Clock Frequency Selection, Master ⁽²¹⁾ 1.71V < V _{dd} < 2.4V	-	-	6	
F _{SPI S}	Maximum Input Clock Frequency Selection, Slave 2.4V < V _{dd} < 3.6V	-	-	12	MHz
	Maximum Input Clock Frequency Selection, Slave 1.71V < V _{dd} < 2.4V	-	-	6	
T _{SS}	Width of SS_ Negated Between Transmissions	50	-	-	ns

Notes

21. Output clock frequency is half of input clock rate.

AC I²C Specifications

Table 20 lists guaranteed maximum and minimum specifications for the entire voltage and temperature ranges.

Table 20. AC Characteristics of the I²C SDA and SCL Pins

Symbol	Description	Standard Mode		Fast Mode		Units
		Min	Max	Min	Max	
F _{SCL I2C}	SCL Clock Frequency	0	100	0	400	kHz
T _{HDSTAI2C}	Hold Time (repeated) START Condition. After this period, the first clock pulse is generated.	4.0	–	0.6	–	μs
T _{LOWI2C}	LOW Period of the SCL Clock	4.7	–	1.3	–	μs
T _{HIGHI2C}	HIGH Period of the SCL Clock	4.0	–	0.6	–	μs
T _{SUSTAI2C}	Setup Time for a Repeated START Condition	4.7	–	0.6	–	μs
T _{HDDATI2C}	Data Hold Time	0	–	0	–	μs
T _{SUDATI2C}	Data Setup Time	250	–	100 ⁽²²⁾	–	ns
T _{SUSTOI2C}	Setup Time for STOP Condition	4.0	–	0.6	–	μs
T _{BUFI2C}	Bus Free Time Between a STOP and START Condition	4.7	–	1.3	–	μs
T _{SPI2C}	Pulse Width of Spikes are Suppressed by the Input Filter	–	–	0	50	ns

Figure 8. Definition of Timing for Fast/Standard Mode on the I²C Bus

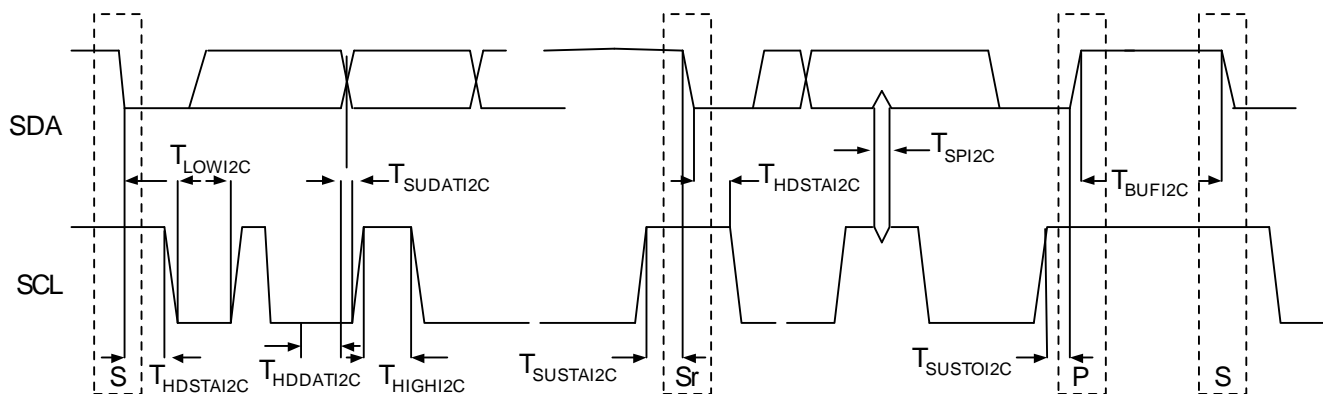

Notes

22. A fast mode I2C bus device can be used in a standard mode I2C bus system, but the requirement $t_{SU, DAT} \geq 250$ ns must then be met. This is automatically the case if the device does not stretch the LOW period of the SCL signal. If such device does stretch the LOW period of the SCL signal, it must output the next data bit to the SDA line $t_{rmax} + t_{SU, DAT} = 1000 + 250 = 1250$ ns (according to the standard mode I2C bus specification) before the SCL line is released.

Package Diagram

This section illustrates the packaging specifications for the enCoRe V LV device, along with the thermal impedances for each package.

Important Note Emulation tools may require a larger area on the target PCB than the chip's footprint. For a detailed description of the enCoRe V LV emulation tools and their dimensions, refer to the development kit.

Packaging Dimensions

Figure 9. 16-Pin (3 x 3 mm) QFN (001-09116)

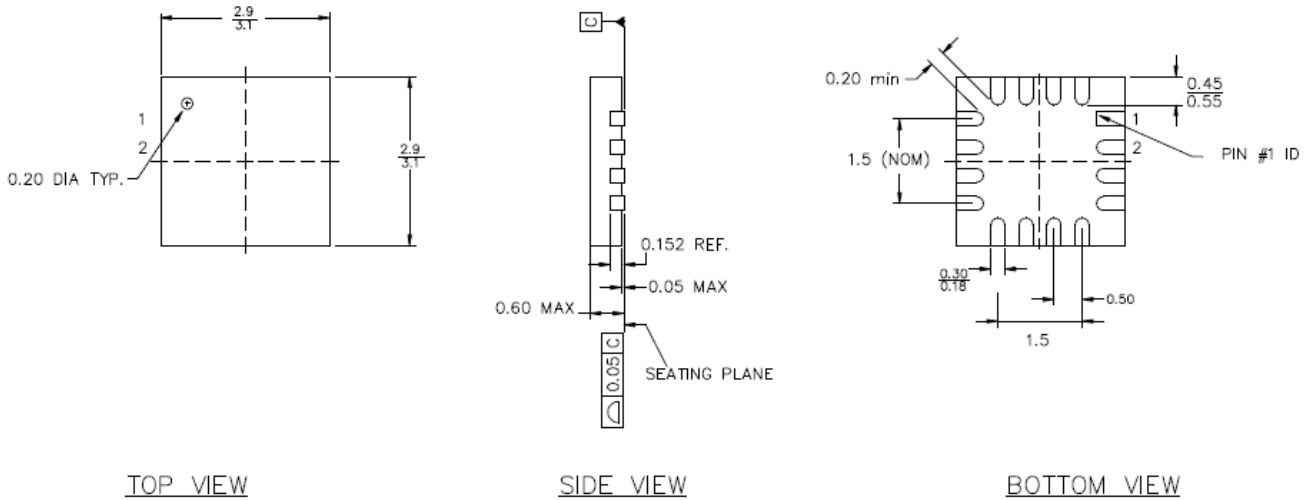

PART NO.	DESCRIPTION
LG16A	LEAD-FREE
LD16A	STANDARD

NOTES:

1. JEDEC # MQ-220
2. Package Weight: 0.014g
3. DIMENSIONS IN MM, MIN
MAX

001-09116 *D

Figure 10. 32-Pin (5 x 5 x 0.55 mm) QFN (001-42168)

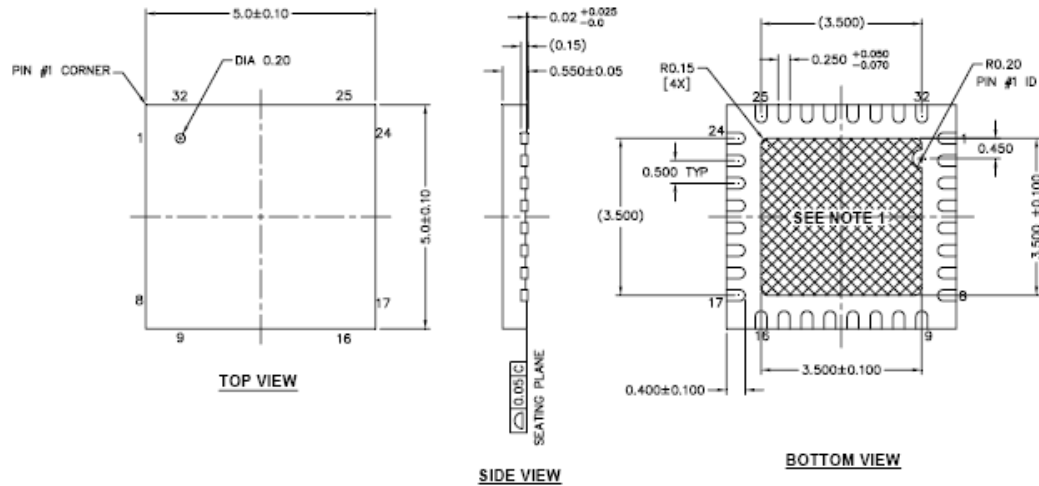

NOTES:

1.  HATCH AREA IS SOLDERABLE EXPOSED PAD
2. BASED ON REF JEDEC # MO-248
3. PACKAGE WEIGHT: 0.0388g
4. DIMENSIONS ARE IN MILLIMETERS

001-42168 *C

Figure 11. 48-Pin (7 x 7 x 0.9 mm) QFN (001-13191)

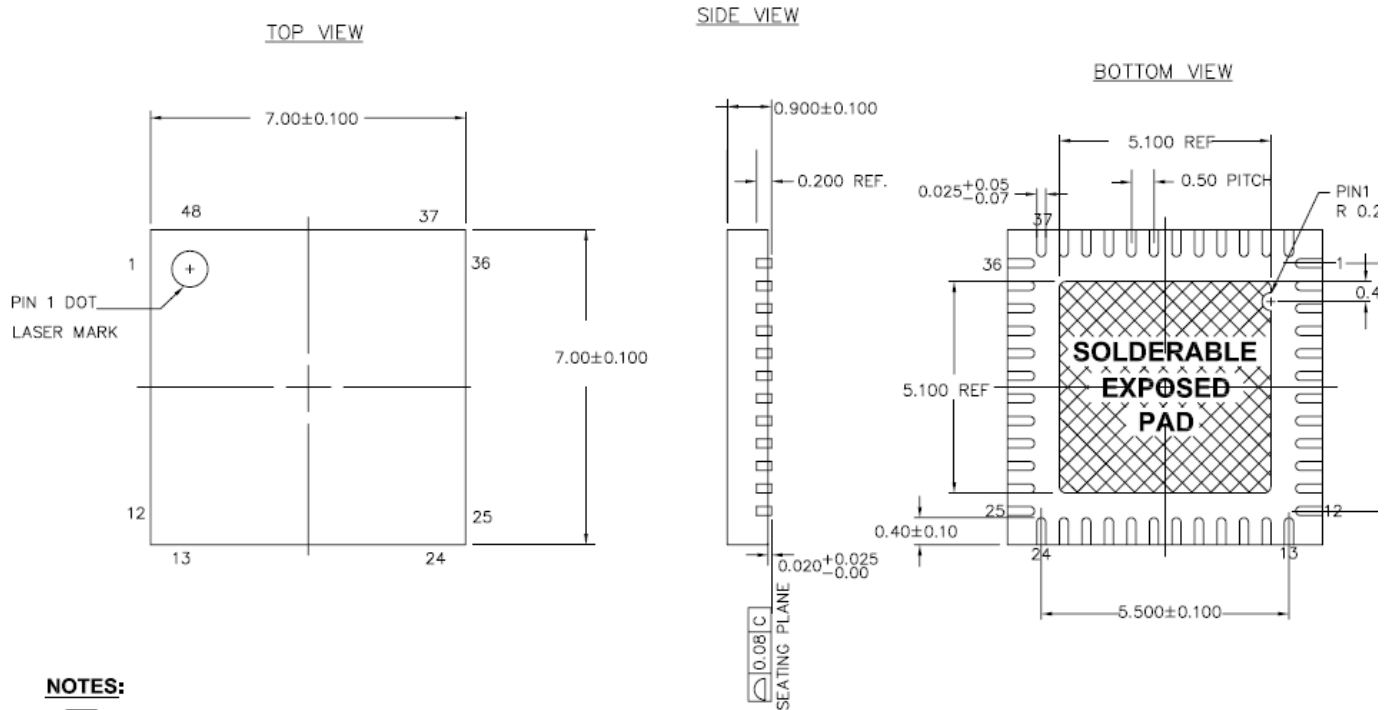

NOTES:

1.  HATCH AREA IS SOLDERABLE EXPOSED METAL.
2. REFERENCE JEDEC#: MO-220
3. PACKAGE WEIGHT: 0.13g
4. ALL DIMENSIONS ARE IN MILLIMETERS

001-13191 *C

Package Handling

Some IC packages require baking before they are soldered onto a PCB to remove moisture that may have been absorbed after leaving the factory. A label on the package has details about the actual bake temperature and the minimum bake time to remove this moisture. The maximum bake time is the aggregate time that the parts exposed to the bake temperature. Exceeding this exposure may degrade device reliability.

Table 21.Package Handling

Parameter	Description	Minimum	Typical	Maximum	Unit
TBAKTEMP	Bake Temperature		125	See package label	°C
TBAKETIME	Bake Time	See package label		72	hours

Thermal Impedances

Package	Typical θ_{JA} ⁽²³⁾
16 QFN	32.69 °C/W
32 QFN ⁽²⁴⁾	19.51 °C/W
48 QFN ⁽²⁴⁾	17.68 °C/W

Solder Reflow Peak Temperature

Following is the minimum solder reflow peak temperature to achieve good solderability.

Package	Minimum Peak Temperature ⁽²⁵⁾	Maximum Peak Temperature
16 QFN	240°C	260°C
32 QFN	240°C	260°C
48 QFN	240°C	260°C

Ordering Information

Ordering Code	Package Information	Flash	SRAM	No. of GPIOs	Target Applications
CY7C60413-16LKXC	16-Pin QFN (3x3 mm)	8K	1K	13	Feature-rich Wireless Mouse
CY7C64013-16LKXCT	16-Pin QFN (3X3 mm)	8K	1K	13	Feature-rich Wireless Mouse
CY7C60445-32LQXC	32-Pin QFN (5x5x0.55 mm)	16K	1K	28	Feature-Rich Wireless Mouse
CY7C60445-32LQXCT	32-Pin QFN - (Tape and Reel) (5x5x0.55 mm)	16K	1K	28	Feature-Rich Wireless Mouse
CY7C60455-48LTXC	48-Pin QFN (7x7x0.9 mm)	16K	1K	36	Mid-Tier Wireless Keyboard
CY7C60455-48LTXCT	48-Pin QFN - (Tape and Reel) (7x7x0.9 mm)	16K	1K	36	Mid-Tier Wireless Keyboard
CY7C60456-48LTXC	48-Pin QFN (7x7x0.9 mm)	32K	2K	36	Feature-Rich Wireless Keyboard
CY7C60456-48LTXCT	48-Pin QFN - (Tape and Reel) (7x7x0.9 mm)	32K	2K	36	Feature-Rich Wireless Keyboard

Notes

23. $T_J = T_A + \text{Power} \times \theta_{JA}$.

24. To achieve the thermal impedance specified for the package, solder the center thermal pad to the PCB ground plane.

25. Higher temperatures may be required based on the solder melting point. Typical temperatures for solder are $220 \pm 5^\circ\text{C}$ with Sn-Pb or $245 \pm 5^\circ\text{C}$ with Sn-Ag-Cu paste. Refer to the solder manufacturer specifications.

Document History Page

Document Title: CY7C604XX, enCoRe™ V Low Voltage Microcontroller				
Document Number: 001-12395				
Rev.	ECN No.	Orig. of Change	Submission Date	Description of Change
**	626516	TYJ	See ECN	New data sheet
*A	735721	TYJ/ARI	See ECN	Added new block diagram, replaced TBDs, corrected values, updated pinout information, changed part number to reflect new specifications.
*B	1120504	ARI	See ECN	Corrected the description to pin 29 on Table 1, the Typ/Max values for I _{SB0} on the DC chip-level specifications, and the Min voltage value for V _{ddIWRITE} in the DC Programming Specifications table. Corrected Flash Write Endurance minimum value in the DC Programming Specifications table. Corrected the Flash Erase Time max value and the Flash Block Write Time max value in the AC Programming Specifications table. Implemented new latest template.
*C	1225864	AESA/ARI	See ECN	Corrected the description to pin 13, 29 on Table 1 and 22,44 on Table 2. Added sections Register Reference, Register Conventions and Register Mapping Tables. Corrected Max values on the DC Chip-Level Specifications table.
*D	1446763	AESA	See ECN	Changed T _{ERASEB} parameter, max value to 18ms in Table 13, AC Programming Specification.
*E	1639963	AESA	See ECN	Post to www.cypress.com
*F	2138889	TYJ/PYRS	See ECN	Updated Ordering Code table: - Ordering code changed for 32-QFN package: From -32LKXC to -32LTXC - Added a new package type – “LTXC” for 48-QFN - Included Tape and Reel ordering code for 32-QFN and 48-QFN packages Changed active current values at 24, 12 and 6MHz in table “DC Chip-Level Specifications” - IDD24: 2.15 to 3.1mA - IDD12: 1.45 to 2.0mA - IDD6: 1.1 to 1.5mA Added information on using P1[0] and P1[1] as the I2C interface during POR or reset events
*G	2583853	TYJ/PYRS/HMT	10/10/08	Converted from Preliminary to Final ADC resolution changed from 10-bit to 8-bit On Page1, SPI Master and Slave – speeds changed Rephrased battery monitoring clause in page 1 to include “with external components” Included ADC specifications table Voh5, Voh7, Voh9 specs changed Flash data retention – condition added to Note [15] Input leakage spec changed to 25 nA max Under AC Char, Frequency accuracy of ILO corrected GPIO rise time for ports 0,1 and ports 2,3 made common AC Programming specifications updated Included AC Programming cycle timing diagram AC SPI specification updated Spec change for 32-QFN package Input Leakage Current maximum value changed to 1 uA Maximum specification for V _{OH5A} parameter changed from 2.0 to 2.1V Minimum voltages for F _{SPIM} and F _{SPIS} specifications changed from 1.8V to 1.71V (Table 18) Updated V _{OHV} parameter in Table 13 Updated Thermal impedance values for the packages - Table 20. Update Development Tools, add Designing with PSoC Designer. Edit, fix links and table format. Update TMs. Update maximum data in Table 12. DC POR and LVD Specifications.

Document Title: CY7C604XX, enCoRe™ V Low Voltage Microcontroller Document Number: 001-12395				
*H	2653717	DVJA/PYRS	02/04/09	<p>Changed master page from CY7C60445, CY7C6045X to CY7C604XX. Updated Features, Functional Overview, Development Tools, and Designing with PSoC Designer sections. Removed 'GUI - graphical user interface' from Document Conventions acronym table. Added Figure 1 and Table 1 (16-pin part information) to Pin Configurations section. Removed 'O - Only a read/write register or bits' in Table 4 Edited Table 8: removed 10-bit resolution information and corrected units column. Added Figure 9 (16-pin part information) to Package Dimensions section. Added 'Package Handling' section. Added 8K part 'CY7C60413-16LKXC' to Ordering Information.</p>

Sales, Solutions, and Legal Information

Worldwide Sales and Design Support

Cypress maintains a worldwide network of offices, solution centers, manufacturer’s representatives, and distributors. To find the office closest to you, visit us at cypress.com/sales.

Products

PSoC	psoc.cypress.com
Clocks & Buffers	clocks.cypress.com
Wireless	wireless.cypress.com
Memories	memory.cypress.com
Image Sensors	image.cypress.com

PSoC Solutions

General	psoc.cypress.com/solutions
Low Power/Low Voltage	psoc.cypress.com/low-power
Precision Analog	psoc.cypress.com/precision-analog
LCD Drive	psoc.cypress.com/lcd-drive
CAN 2.0b	psoc.cypress.com/can
USB	psoc.cypress.com/usb

© Cypress Semiconductor Corporation, 2006-2009. The information contained herein is subject to change without notice. Cypress Semiconductor Corporation assumes no responsibility for the use of any circuitry other than circuitry embodied in a Cypress product. Nor does it convey or imply any license under patent or other rights. Cypress products are not warranted nor intended to be used for medical, life support, life saving, critical control or safety applications, unless pursuant to an express written agreement with Cypress. Furthermore, Cypress does not authorize its products for use as critical components in life-support systems where a malfunction or failure may reasonably be expected to result in significant injury to the user. The inclusion of Cypress products in life-support systems application implies that the manufacturer assumes all risk of such use and in doing so indemnifies Cypress against all charges.

Any Source Code (software and/or firmware) is owned by Cypress Semiconductor Corporation (Cypress) and is protected by and subject to worldwide patent protection (United States and foreign), United States copyright laws and international treaty provisions. Cypress hereby grants to licensee a personal, non-exclusive, non-transferable license to copy, use, modify, create derivative works of, and compile the Cypress Source Code and derivative works for the sole purpose of creating custom software and/or firmware in support of licensee product to be used only in conjunction with a Cypress integrated circuit as specified in the applicable agreement. Any reproduction, modification, translation, compilation, or representation of this Source Code except as specified above is prohibited without the express written permission of Cypress.

Disclaimer: CYPRESS MAKES NO WARRANTY OF ANY KIND, EXPRESS OR IMPLIED, WITH REGARD TO THIS MATERIAL, INCLUDING, BUT NOT LIMITED TO, THE IMPLIED WARRANTIES OF MERCHANTABILITY AND FITNESS FOR A PARTICULAR PURPOSE. Cypress reserves the right to make changes without further notice to the materials described herein. Cypress does not assume any liability arising out of the application or use of any product or circuit described herein. Cypress does not authorize its products for use as critical components in life-support systems where a malfunction or failure may reasonably be expected to result in significant injury to the user. The inclusion of Cypress' product in a life-support systems application implies that the manufacturer assumes all risk of such use and in doing so indemnifies Cypress against all charges.

Use may be limited by and subject to the applicable Cypress software license agreement.