

### Key Features

- Low-Dropout Regulator Supports Input Voltages Down to 1.4V
- Output Voltage Available in 0.9V, 1.0V, 1.2V, 1.5V, 1.8V, 2.5V, 2.8V, 2.85V, 3.0V, 3.3V
- Low Dropout Voltage: 300mV@ 3A
- Stable with a Ceramic Output Capacitor of 1.0uF or Higher
- Low Quiescent Current
- Current Limit
- Over Temperature Shutdown
- Short Circuit Current Protection
- Low Temperature Coefficient
- Standard TO-263, TO-220 and SOP-8 (Exposed Pad) Packages
- Pb-Free Package

### General Description

The PAM3130 is a 3A CMOS LDO regulator that features a low quiescent current, ultra low input, output, and dropout voltages, as well as over temperature protection. It is available in TO-263, TO-220 and SOP-8(Exposed Pad) packages. The fixed output voltage of the PAM3130 is set at the factory and trimmed to  $\pm 2.0\%$ . The PAM3130 is stable with a ceramic output capacitor of 1.0uF or higher.

This family of regulators can provide either a stand-alone power supply solution or act as a post regulator for switch mode power supplies. They are particularly well suited for applications requiring low input and output voltages.

### Applications

- DSP, FPGA, and Microprocessor Power Supplies
- 1.2V Core Voltage for DSPs
- SATA Power Supply
- LCD TV/ Monitors
- Wireless Devices
- Communication Devices
- Portable Electronics
- Post Regulator for SMPS

### Typical Application

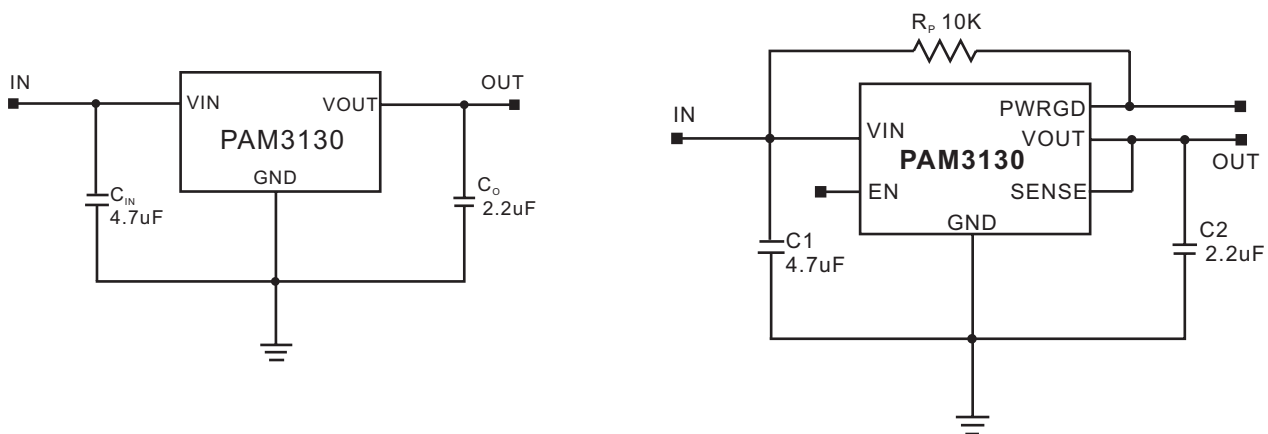

### Block Diagram

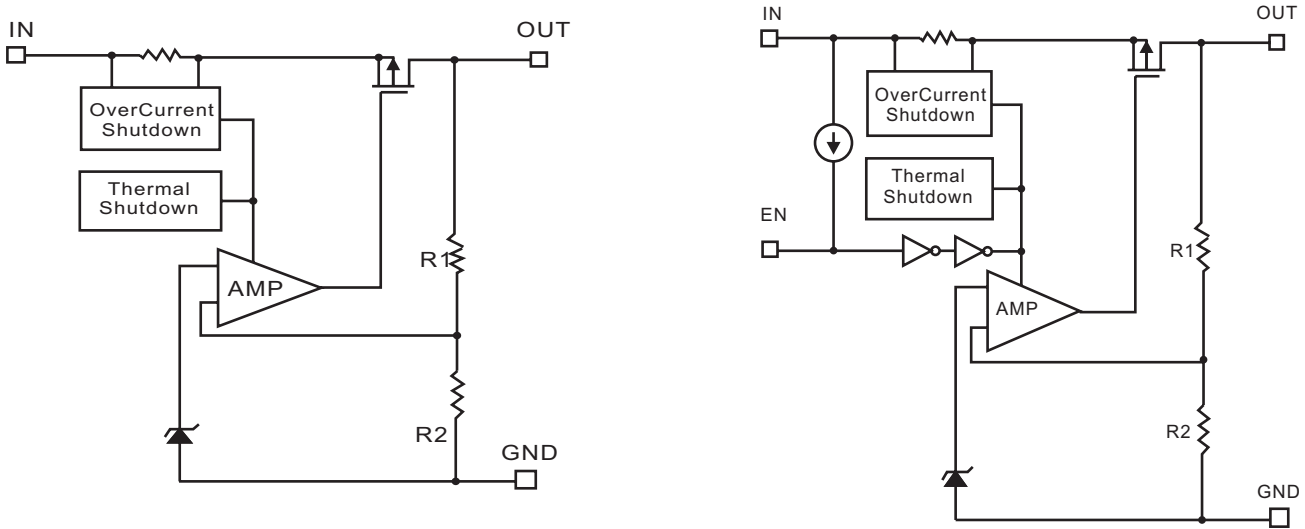

### Pin Configuration & Marking Information

Top View  
TO-220

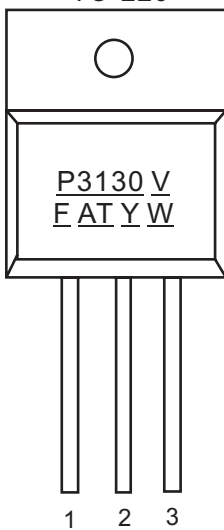

V: Voltage Code  
 F: Internal Code  
 A: Assembly Code  
 T: Testing Code  
 Y: Year  
 W: Weekly

Pin Number	Name	Function
1	VIN	Input
2	GND	Ground(Heatsink)
3	VOUT	Output

### Pin Configuration & Marking Information<sup>(continued)</sup>

Top View  
TO-263-5L

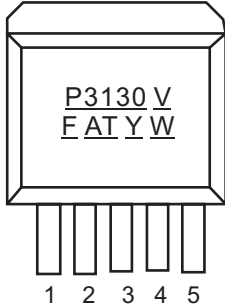

V: Voltage Code  
F: Internal Code  
A: Assembly Code  
T: Testing Code  
Y: Year  
W: Weekly

Pin Number	Name	Function
1	VIN	Input
2	EN	Enable Pin
3	GND	Ground (Heatsink)
4	PWRGD/SENSE	Power Good/Sense
5	VOUT	Output

Top View  
SOP-8(EPD)

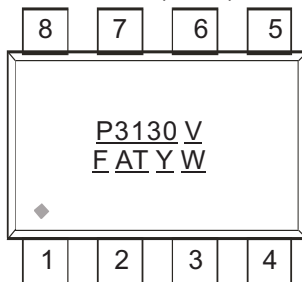

V: Voltage Code  
F: Internal Code  
A: Assembly Code  
T: Testing Code  
Y: Year  
W: Weekly

Pin Number	Name	Function
1	GND	Ground
2	VIN	Input
3	EN	Enable Pin
4	GND	Ground
5	PWRGD	Power Good
6	SENSE	Sense
7	VOUT	Output
8	GND	Ground



### Absolute Maximum Ratings

These are stress ratings only and functional operation is not implied. Exposure to absolute maximum ratings for prolonged time periods may affect device reliability. All voltages are with respect to ground.

Input Voltage.....	4.0V	Maximum Output Current.....	$P_D / (V_{IN} - V_O)$
Output Pin Voltage.....	-0.3V to $V_{IN} + 0.3V$	Storage Temperature.....	-65°C to 150°C
Operation Temperature Range.....	-40°C to 85°C	Maximum Junction Temperature.....	150°C
Operation Junction Temperature.....	-40°C to 125°C	Soldering Temperature.....	300°C, 5sec

### Recommended Operating Conditions

Supply Voltage Range.....	1.4V to 3.6V	Junction Temperature Range.....	-40°C to 125°C
Operation Temperature Range.....	-40°C to 85°C		

### Thermal Information

Parameter	Symbol	Package	Maximum	Unit
Thermal Resistance (Junction to Case)	$\theta_{JC}$	TO-263	7	°C/W
		TO-220	7	
		SOP-8	90	
Thermal Resistance (Junction to Ambient)	$\theta_{JA}$	TO-263	60	
		TO-220	50	
		SOP-8	11	
Internal Power Dissipation	$P_D$	TO-263	2800	mW
		TO-220	3000	

### Electrical Characteristic

$V_{IN}=V_O+0.5V$ ,  $T_A=25^\circ C$ ,  $C_{IN}=4.7\mu F$ ,  $C_O=2.2\mu F$ , unless otherwise noted.

Parameters	Symbol	Test Conditions	MIN	TYP	MAX	UNITS		
Input Voltage Range	$V_{IN}$		Note 1		3.6	V		
Output Voltage Accuracy	$V_O$	$I_O=100mA$	-2		2	%		
Dropout Voltage	$V_{DROD}$	$I_O=500mA$	$V_O=0.9V$		330	500	mV	
			$V_O=1.0V$		220	400		
			$2.5V > V_O \geq 1.2V$		50	200		
			$V_O \geq 2.5V$		40	150		
		$I_O=3.0A$	$V_O=0.9V$		500			
			$V_O=1.0V$		400			
			$2.5V > V_O \geq 1.2V$		350			
			$V_O \geq 2.5V$		300			
Short Circuit Current	$I_{SC}$	$V_O < 0.3V$		1.0		A		
Output Current	$I_O$		3.0		Note 2	A		
Quiescent Current	$I_Q$	$I_O=0mA$		90	150	$\mu A$		
Ground Pin Current	$I_{GND}$	$I_O=1mA$ to $3.0A$			1.0	mA		
Line Regulation	LNR	$V_O \leq 2.5V, I_O=10mA$ $V_{IN}=V_O+0.5V$ to $V_O+1.5V$		0.5	1.0	%V		
		$V_O > 2.5V, I_O=10mA$ $V_{IN}=3.3V$ to $3.6V$						
Load Regulation	LDR	$I_O=1mA$ to $3.0A, V_{IN}=V_O+0.5V$		0.5	2	%/A		
Over Temperature Shutdown	OTS			150		$^\circ C$		
Over Temperature Hysteresis	OTH			50		$^\circ C$		
Temperature Coefficient	TC			40		ppm/ $^\circ C$		
Power Supply Ripple Rejection	PSRR	$I_O=100mA, V_O=1.5V$	$f=100Hz$		55	dB		
			$f=1KHz$		55			
			$f=10KHz$		35			
Output Noise	$V_n$	$f=10Hz$ to $100kHz$		40		$\mu V_{rms}$		

Note1: The minimum input voltage ( $V_{IN(MIN)}$ ) of the PAM3130 is determined by output voltage and dropout voltage. The minimum input voltage is defined as:

$$V_{IN(MIN)} = V_O + V_{drop}$$

Note 2: Output current is limited by  $P_D$ , maximum  $I_O = P_D / (V_{IN(MAX)} - V_O)$ .

### Typical Performance Characteristics

$T_A=25^\circ\text{C}$ ,  $C_{IN}=4.7\mu\text{F}$ ,  $C_O=2.2\mu\text{F}$ , unless otherwise noted.

#### 1. Output Voltage vs Input Voltage

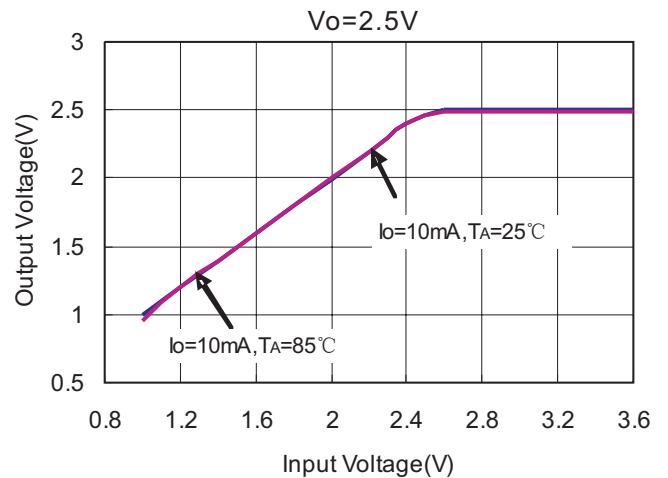
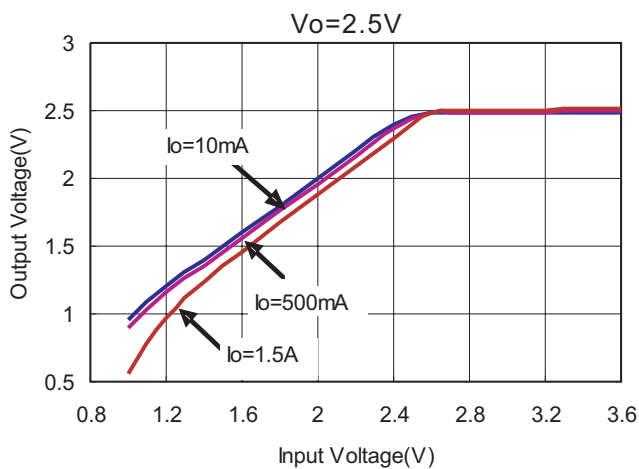
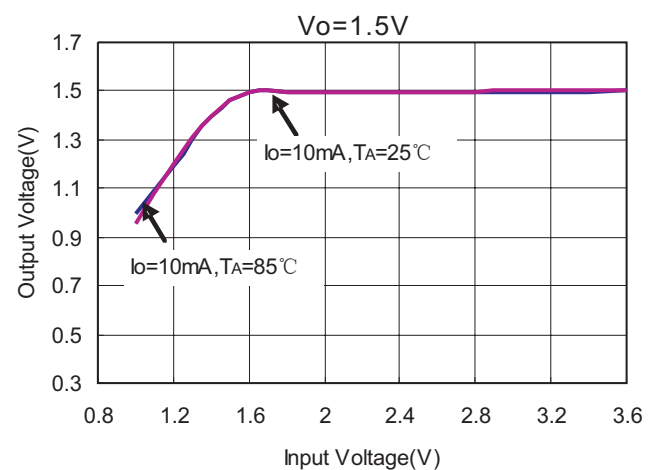
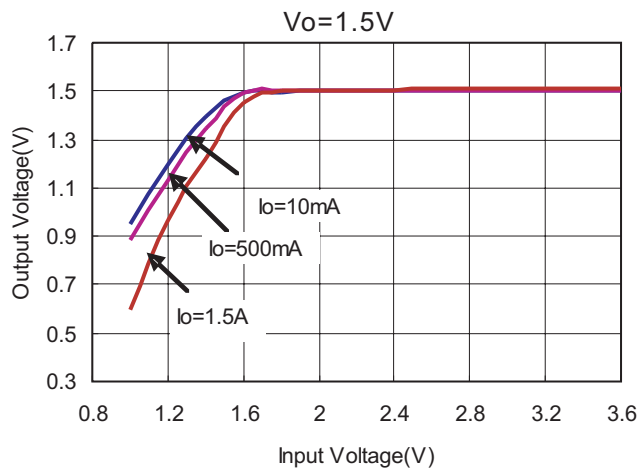
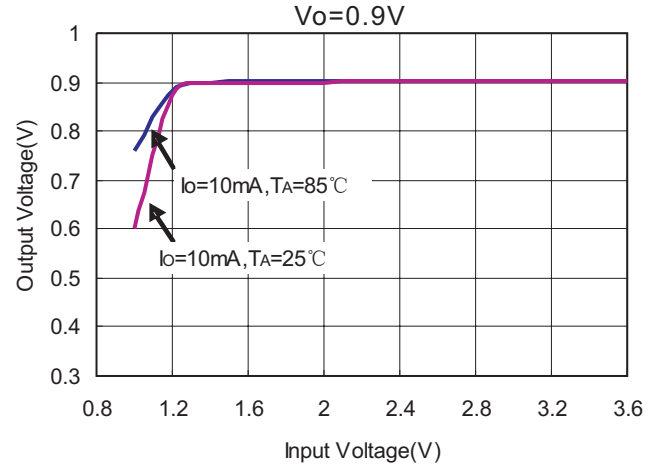
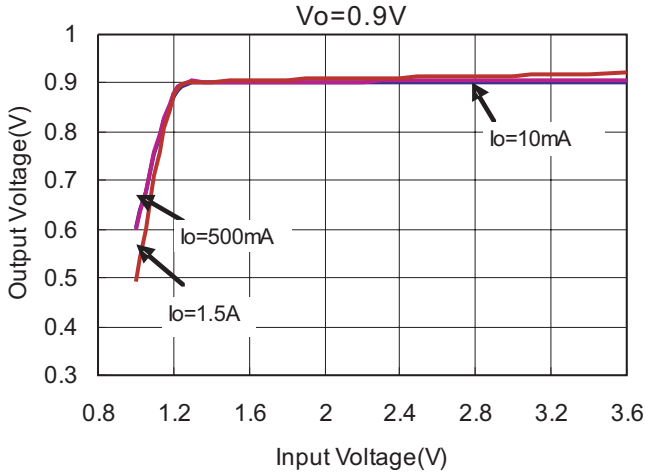

### Typical Performance Characteristics (continued)

2. Output Voltage vs Output Current

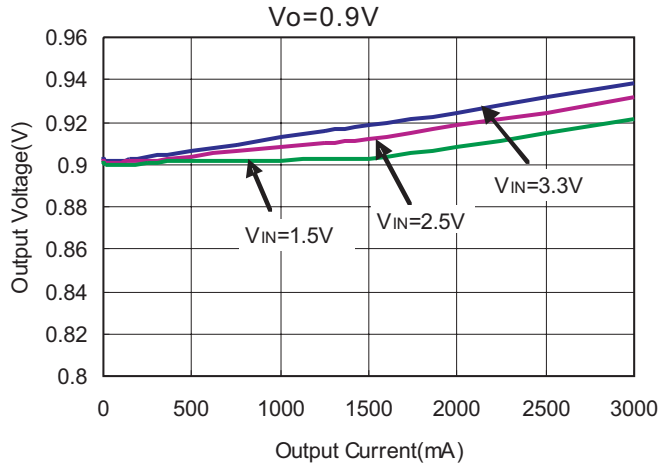

3. Output Voltage vs Temperature

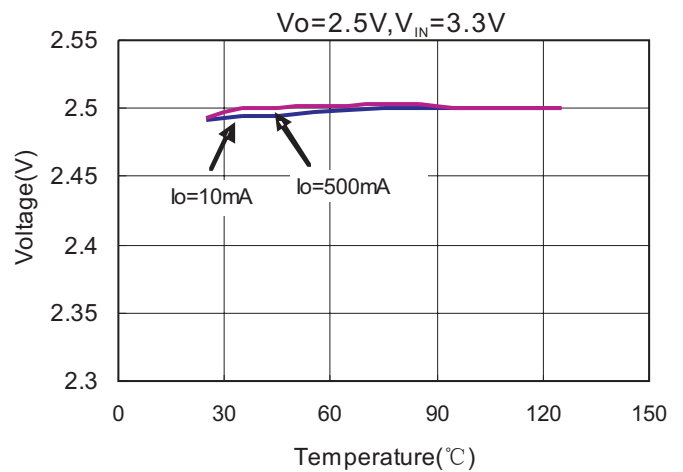
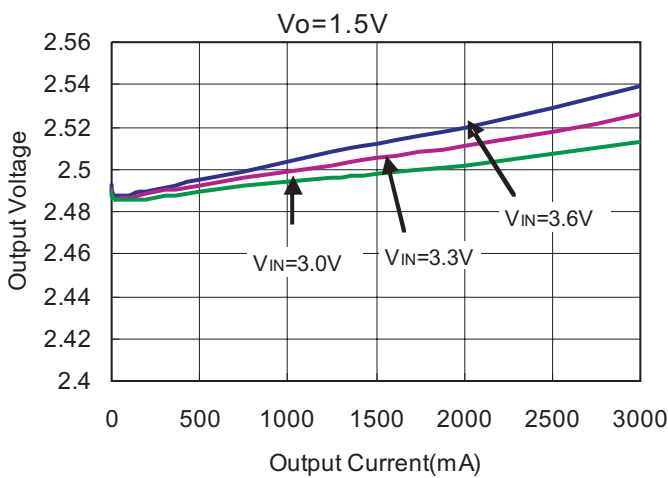
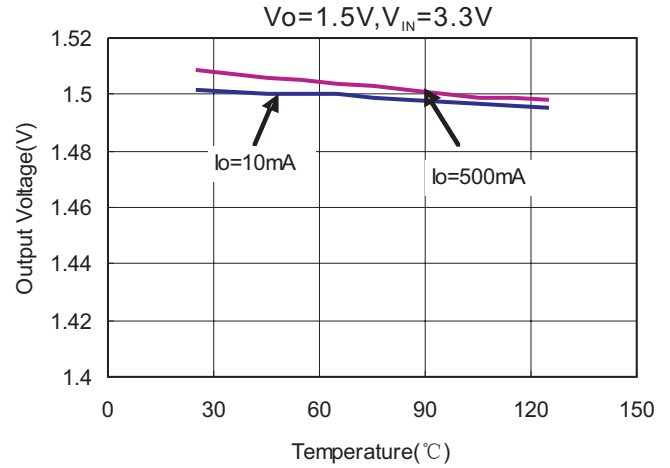
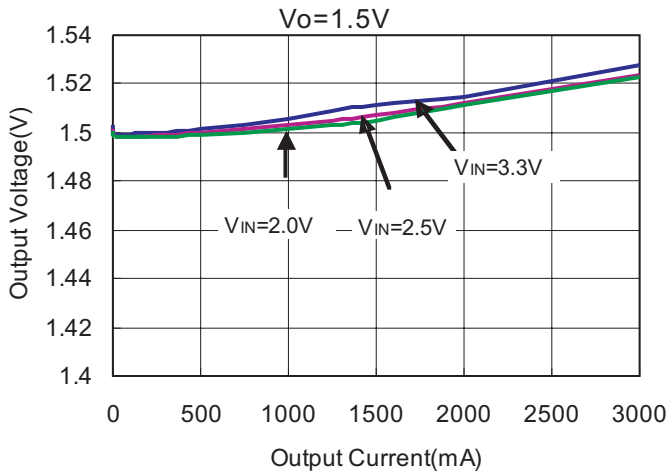
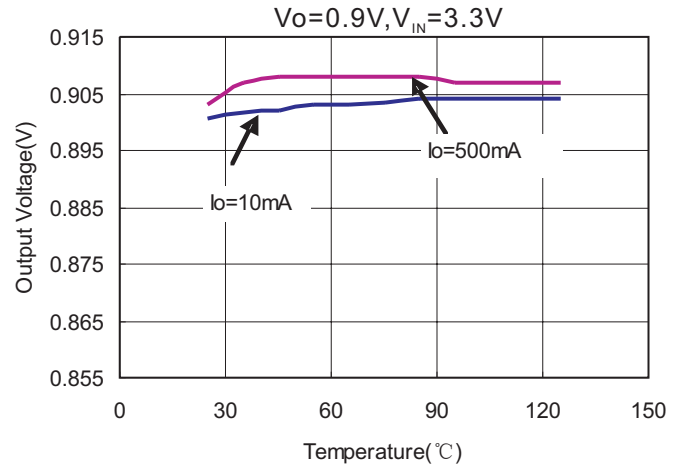

### Typical Performance Characteristics (continued)

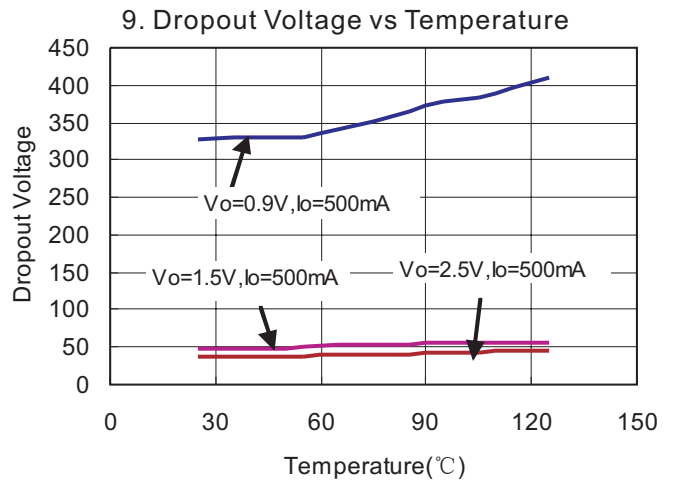
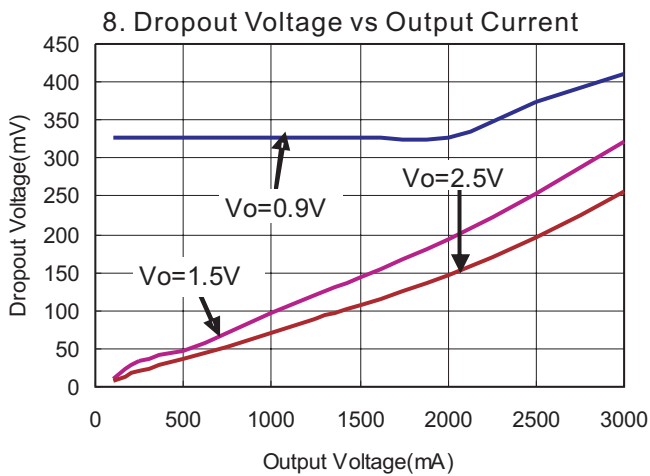
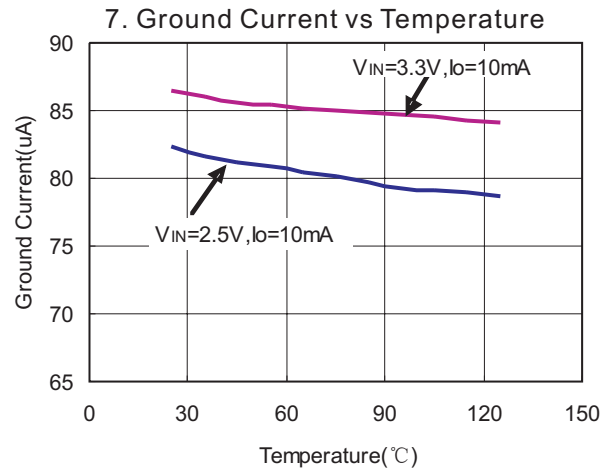
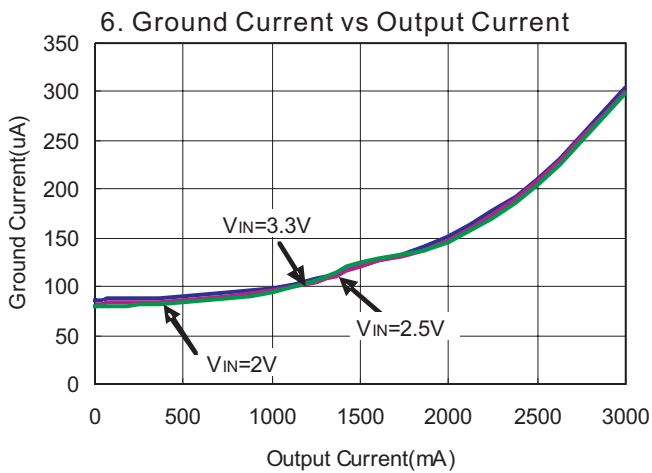
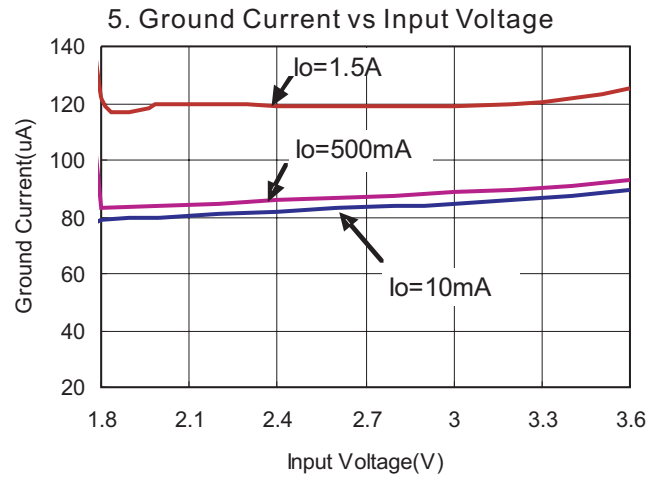
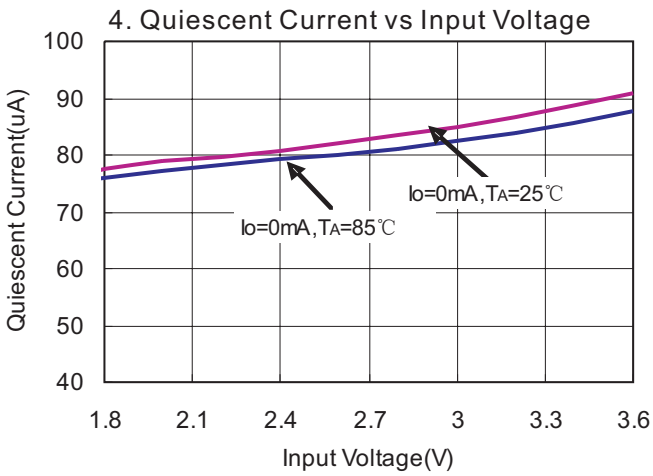



### Typical Performance Characteristics (continued)

10. Ripple Rejection vs Frequency

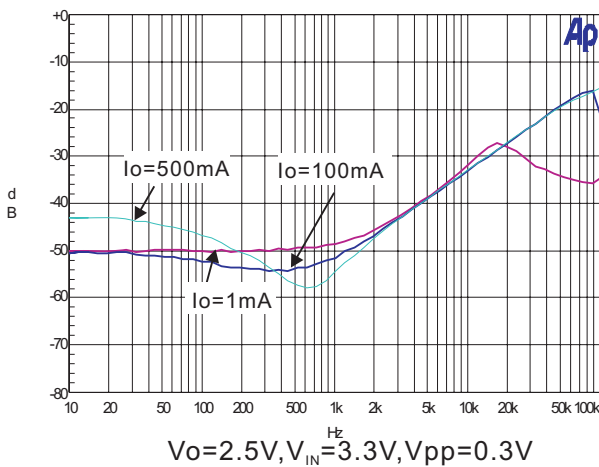
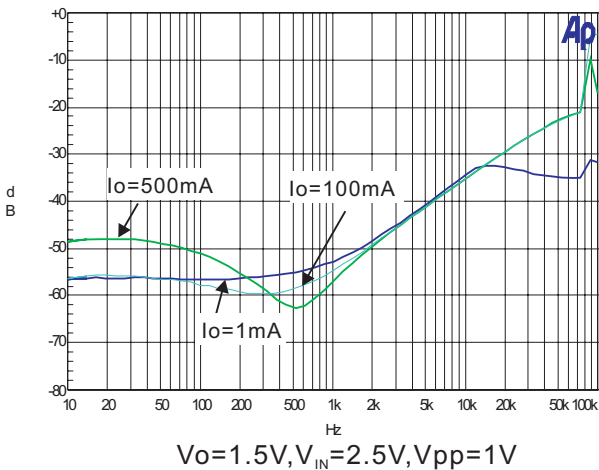
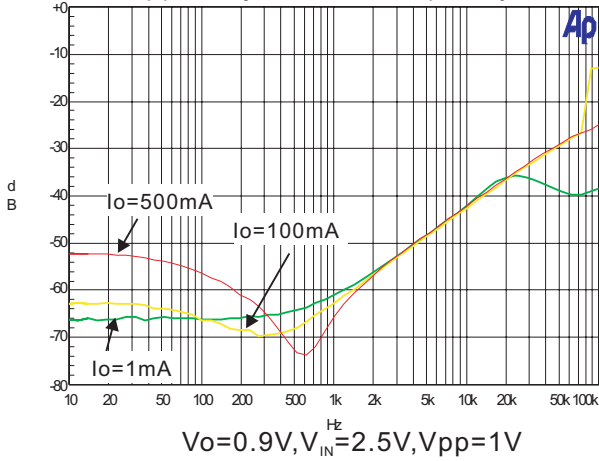

11. Load Transient Response

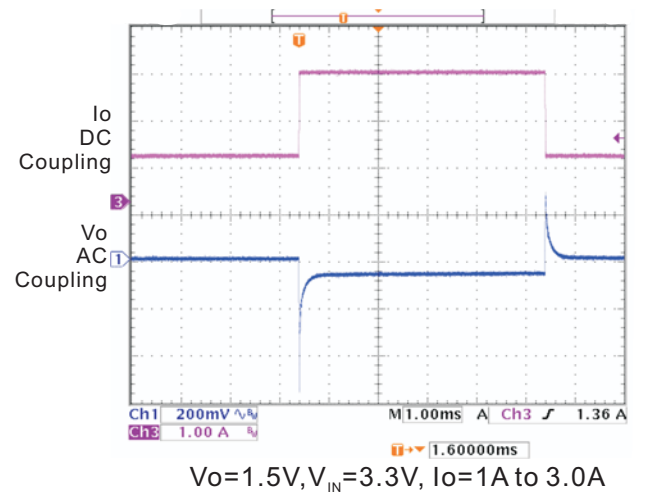
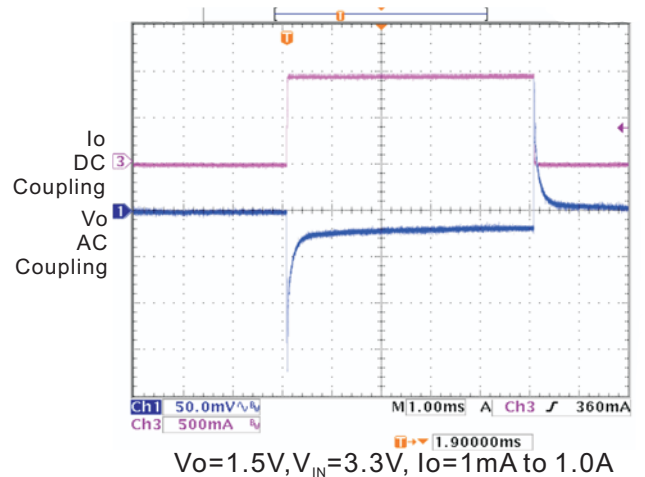
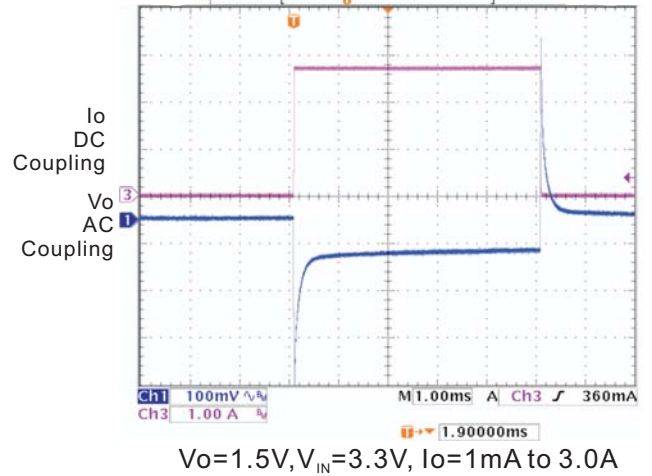

### Typical Performance Characteristics (continued)

12. Line Transient Response

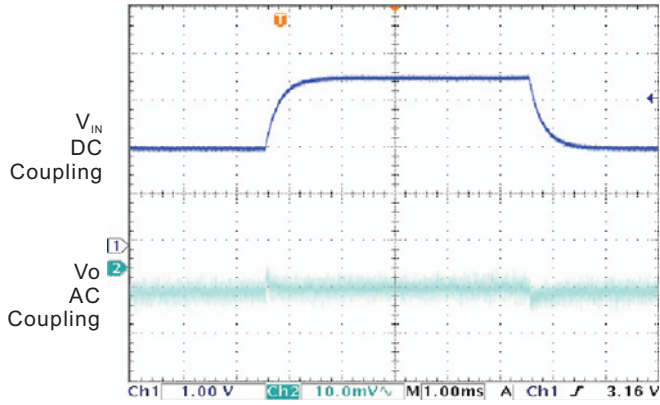

$V_o=1.5V, I_o=100mA, V_{IN}=2.0V \text{ to } 3.3V$

### Application Information

The PAM3130 family of low-dropout (LDO) regulators have several features that allow them to apply to a wide range of applications. The family operates with very low input voltage (1.4V) and low dropout voltage (typically 300mV at full load), making it an efficient stand-alone power supply or post regulator for battery or switch mode power supplies. The 3A output current make the PAM3130 family suitable for powering many microprocessors and FPGA supplies. The PAM3130 family also has low output noise (typically 40µVRMS with 2.2µF output capacitor), making it ideal for use in telecom equipment.

#### External Capacitor Requirements

A 2.2µF or larger ceramic input bypass capacitor, connected between  $V_{IN}$  and GND and located close to the PAM3130, is required for stability. A 1.0µF minimum value capacitor from  $V_O$  to GND is also required. To improve transient response, noise rejection, and ripple rejection, an additional 10µF or larger, low ESR capacitor is recommended at the output. A higher value, low ESR output capacitor may be necessary if large, fast-rise-time load transients are anticipated and the device is located several inches from the power source, especially if the minimum input voltage of 1.4 V is used.

#### Regulator Protection

The PAM3130 features internal current limiting, thermal protection and short circuit protection. During normal operation, the PAM3130 limits output current to about 4.5A. When current limiting engages, the output voltage scales back linearly until the over current condition ends. While current limiting is designed to prevent gross device failure, care should be taken not to exceed the power dissipation ratings of the package. If the temperature of the device exceeds 150°C, thermal-protection circuitry will shut down. Once the device has cooled down to approximately 50°C below the high temp trip point, regulator operation resumes. The short circuit current of the PAM3130 is about 1A when its output pin is shorted to ground.

#### Thermal Information

The amount of heat that an LDO linear regulator

generates is:

$$P_D = (V_{IN} - V_O) I_O$$

All integrated circuits have a maximum allowable junction temperature ( $T_J \text{ max}$ ) above which normal operation is not assured. A system designer must design the operating environment so that the operating junction temperature ( $T_J$ ) does not exceed the maximum junction temperature ( $T_J \text{ max}$ ). The two main environmental variables that a designer can use to improve thermal performance are air flow and external heatsinks. The purpose of this information is to aid the designer in determining the proper operating environment for a linear regulator that is operating at a specific power level.

In general, the maximum expected power ( $P_D(\text{max})$ ) consumed by a linear regulator is computed as:

$$P_{D\text{max}} = (V_{I(\text{avg})} - V_{O(\text{avg})}) \times I_{O(\text{avg})} + V_{I(\text{avg})} \times I_{(Q)} \quad (1)$$

Where:

- $V_{I(\text{avg})}$  is the average input voltage.
- $V_{O(\text{avg})}$  is the average output voltage.
- $I_{O(\text{avg})}$  is the average output current.
- $I_{(Q)}$  is the quiescent current.

For most LDO regulators, the quiescent current is insignificant compared to the average output current; therefore, the term  $V_{I(\text{avg})} \times I_{(Q)}$  can be neglected. The operating junction temperature is computed by adding the ambient temperature ( $T_A$ ) and the increase in temperature due to the regulator's power dissipation. The temperature rise is computed by multiplying the maximum expected power dissipation by the sum of the thermal resistances between the junction and the case ( $R_{\theta JC}$ ), the case to heatsink ( $R_{\theta CS}$ ), and the heatsink to ambient ( $R_{\theta SA}$ ). Thermal resistances are measures of how effectively an object dissipates heat. Typically, the larger the device, the more surface area available for power dissipation so that the object's thermal resistance will be lower.

### Ordering Information

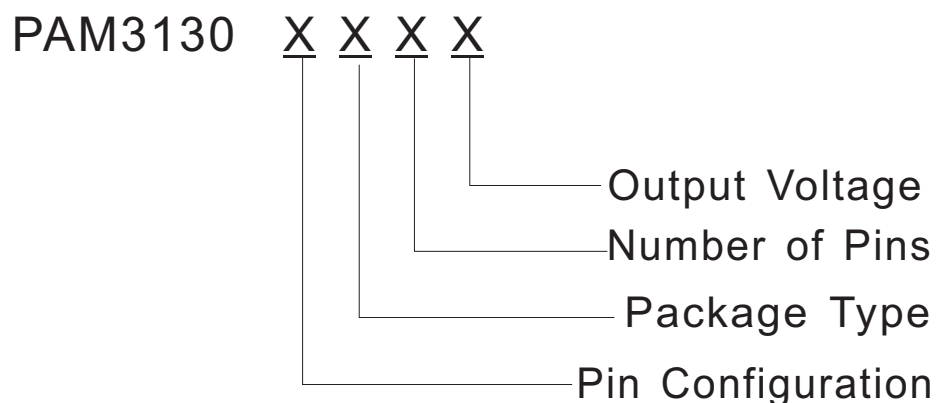

Pin Configuration	Package Type	Number of Pins	Output Voltage
A Type	F: TO-220	A: 3	090: 0.9V
1. VIN	M: TO-263	B: 5	100: 1.0V
2. GND	E: SOP-8	C: 8	120: 1.2V
3. VOUT			150: 1.5V
B Type			180: 1.8V
1. VIN			250: 2.5V
2. EN			280: 2.8V
3. GND			285: 2.85V
4. PWRGD			300: 3.0V
5. VOUT			330: 3.3V
C Type			
1. VIN			
2. EN			
3. GND			
4. SENSE			
5. VOUT			
D Type			
1. GND			
2. VIN			
3. EN			
4. GND			
5. PWRGD			
6. SENSE			
7. VOUT			
8. GND			

Please consult PAM sales office or authorized Rep. /Distributor for output voltage and package type availability.



### Ordering Information

Part Number	Output Voltage	Marking	Package Type	Standard Package
PAM3130AFA090	0.9V	P3130Z FATYW	TO-220	50Units/Tube
PAM3130BMB090	0.9V	P3130Z FATYW	TO-263-5L	800Units/Tape&Reel
PAM3130CMB090	0.9V	P3130Z FATYW	TO-263-5L	800Units/Tape&Reel
PAM3130DEC090	0.9V	P3130Z FATYW	SOP-8	2,500Units/Tape&Reel
PAM3130AFA100	1.0V	P3130Y FATYW	TO-220	50Units/Tube
PAM3130BMB100	1.0V	P3130Y FATYW	TO-263-5L	800Units/Tape&Reel
PAM3130CMB100	1.0V	P3130Y FATYW	TO-263-5L	800Units/Tape&Reel
PAM3130DEC100	1.0V	P3130Y FATYW	SOP-8	2,500Units/Tape&Reel
PAM3130AFA120	1.2V	P3130B FATYW	TO-220	50Units/Tube
PAM3130BMB120	1.2V	P3130B FATYW	TO-263-5L	800Units/Tape&Reel
PAM3130CMB120	1.2V	P3130B FATYW	TO-263-5L	800Units/Tape&Reel
PAM3130DEC120	1.2V	P3130B FATYW	SOP-8	2,500Units/Tape&Reel
PAM3130AFA150	1.5V	P3130C FATYW	TO-220	50Units/Tube
PAM3130BMB150	1.5V	P3130C FATYW	TO-263-5L	800Units/Tape&Reel
PAM3130CMB150	1.5V	P3130C FATYW	TO-263-5L	800Units/Tape&Reel
PAM3130DEC150	1.5V	P3130C FATYW	SOP-8	2,500Units/Tape&Reel
PAM3130AFA180	1.8V	P3130E FATYW	TO-220	50Units/Tube
PAM3130BMB180	1.8V	P3130E FATYW	TO-263-5L	800Units/Tape&Reel



### Ordering Information (continued)

Part Number	Output Voltage	Marking	Package Type	Standard Package
PAM3130CMB180	1.8V	P3130E FATYW	TO-263-5L	800Units/Tape&Reel
PAM3130DEC180	1.8V	P3130E FATYW	SOP-8	2,500Units/Tape&Reel
PAM3130AFA250	2.5V	P3130G FATYW	TO-220	50Units/Tube
PAM3130BMB250	2.5V	P3130G FATYW	TO-263-5L	800Units/Tape&Reel
PAM3130CMB250	2.5V	P3130G FATYW	TO-263-5L	800Units/Tape&Reel
PAM3130DEC250	2.5V	P3130G FATYW	SOP-8	2,500Units/Tape&Reel
PAM3130AFA280	2.8V	P3130H FATYW	TO-220	50Units/Tube
PAM3130BMB280	2.8V	P3130H FATYW	TO-263-5L	800Units/Tape&Reel
PAM3130CMB280	2.8V	P3130H FATYW	TO-263-5L	800Units/Tape&Reel
PAM3130DEC280	2.8V	P3130H FATYW	SOP-8	2,500Units/Tape&Reel
PAM3130AFA285	2.85V	P3130I FATYW	TO-220	50Units/Tube
PAM3130BMB285	2.85V	P3130I FATYW	TO-263-5L	800Units/Tape&Reel
PAM3130CMB285	2.85V	P3130I FATYW	TO-263-5L	800Units/Tape&Reel
PAM3130DEC285	2.85V	P3130I FATYW	SOP-8	2,500Units/Tape&Reel
PAM3130AFA300	3.0V	P3130J FATYW	TO-220	50Units/Tube
PAM3130BMB300	3.0V	P3130J FATYW	TO-263-5L	800Units/Tape&Reel
PAM3130CMB300	3.0V	P3130J FATYW	TO-263-5L	800Units/Tape&Reel
PAM3130DEC300	3.0V	P3130J FATYW	SOP-8	2,500Units/Tape&Reel



### Ordering Information<sup>(continued)</sup>

Part Number	Output Voltage	Marking	Package Type	Standard Package
PAM3130AFA330	3.3V	P3130K FATYW	TO-220	50Units/Tube
PAM3130BMB330	3.3V	P3130K FATYW	TO-263-5L	800Units/Tape&Reel
PAM3130CMB330	3.3V	P3130K FATYW	TO-263-5L	800Units/Tape&Reel
PAM3130DEC330	3.3V	P3130K FATYW	SOP-8	2,500Units/Tape&Reel

Please consult PAM sales office or authorized Rep. /Distributor for output voltage and package type availability.

### Outline Dimension

TO-263-5L

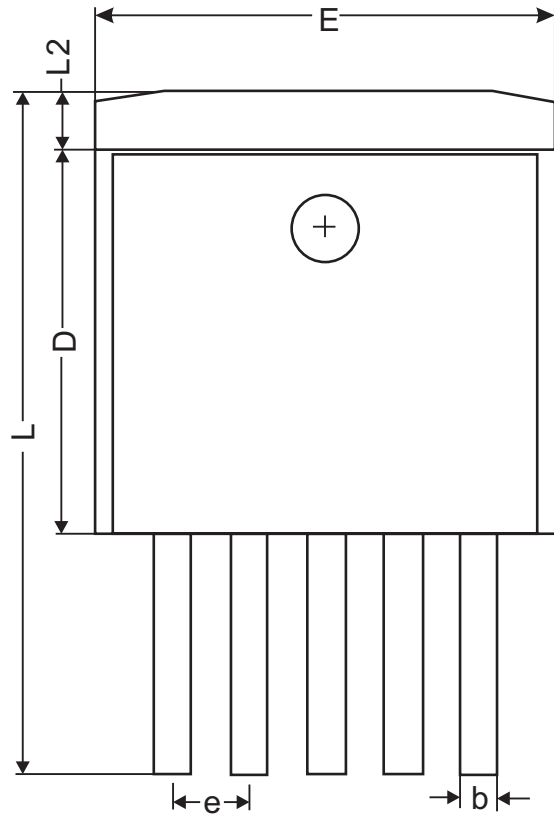
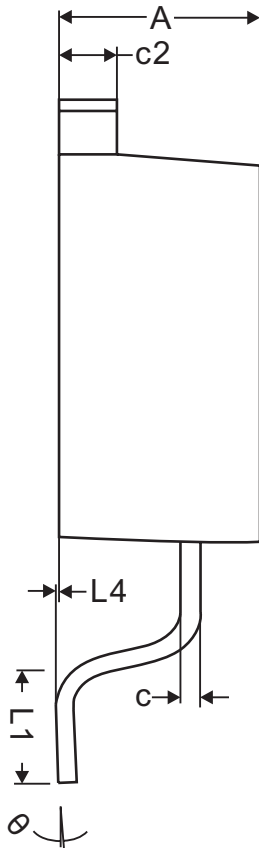

Dimensions(Millimeter)			
Symbol	MIN	NOM	MAX
A	4.40	4.60	4.80
b	0.66	0.78	0.91
L4	0.00	0.15	0.30
c	0.36	0.43	0.50
L3	1.50 REF.		
L1	2.29	2.54	2.79
E	9.80	10.1	10.4
c2	1.25	1.35	1.45
L2	1.27 REF.		
D	8.6	8.8	9.0
e	1.70 REF.		
L	14.6	15.2	15.8
θ	0°	4°	8°



### Outline Dimension

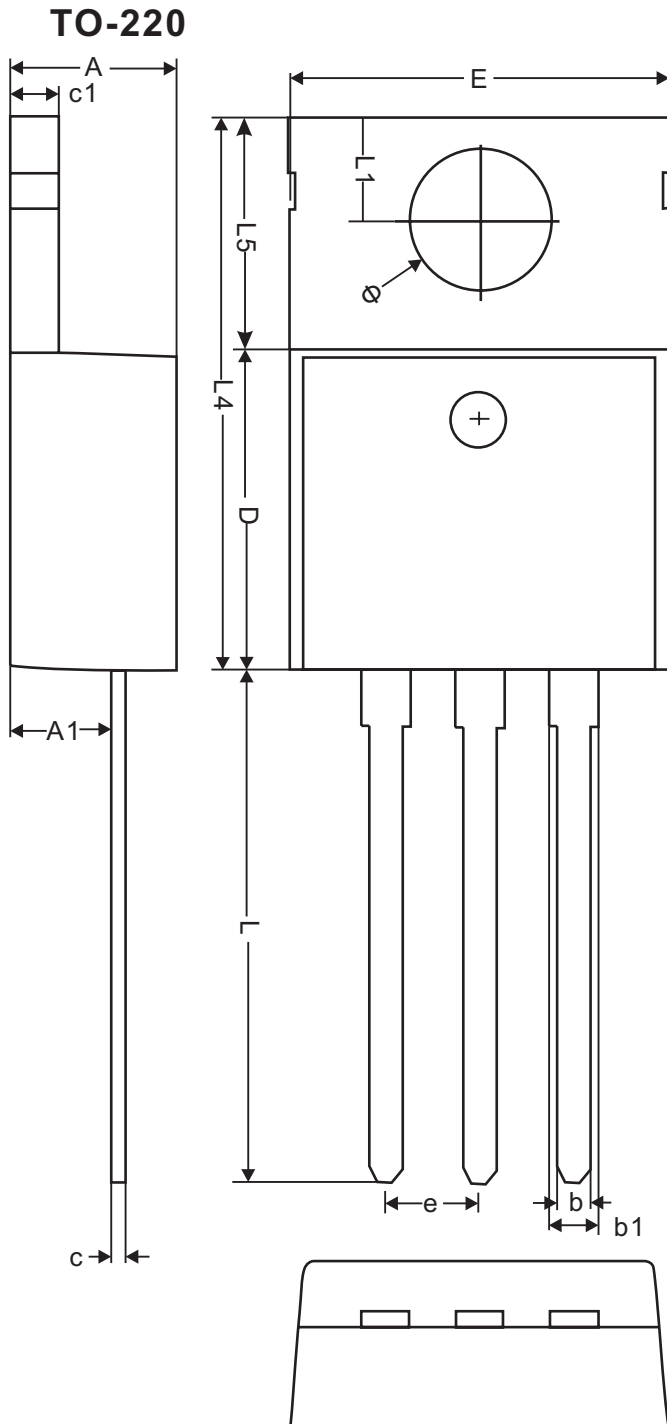

Dimensions(Millimeter)			
Symbol	MIN	NOM	MAX
A	4.40	4.60	4.80
b	0.76	0.88	1.0
D	8.60	8.80	9.00
c	0.36	0.43	0.50
E	9.80	10.1	10.4
L4	14.70	15.0	15.30
L5	6.20	6.40	6.60
c1	1.25	1.35	1.45
b1	1.17	1.32	1.47
L	13.25	13.75	14.25
e	2.54 REF.		
L1	2.60	2.74	2.89
$\phi$	3.71	3.93	3.96
A1	2.60	2.70	2.80

### Outline Dimension

#### SOP-8

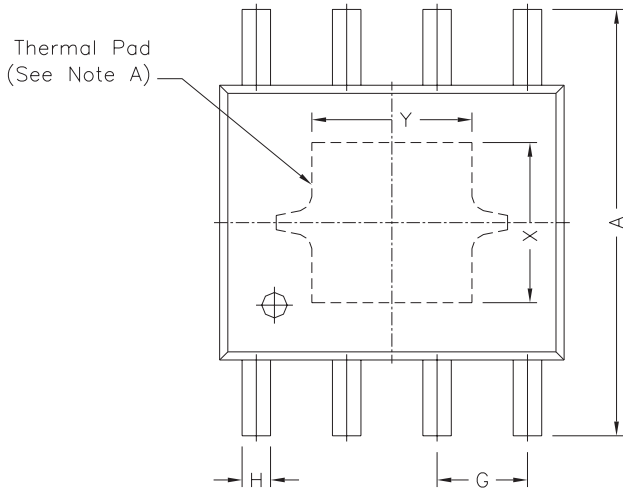

REF.	DIMENSIONS	
	Millimeters	
	Min.	Max.
A	5.80	6.20
B	4.80	5.00
C	3.80	4.00
D	0°	8°
E	0.40	0.90
F	0.19	0.25
M	0	0.15
H	0.35	0.49
L	1.35	1.75
G	1.27 TYP.	
Option1	X	2.28
	Y	2.28
Option2	X	2.41
	Y	3.30

