

**CONNECTOR  
 DESIGNATORS**  
**A-B\*-C-D-E-F**  
**G-H-J-K-L-S**  
 \* Conn. Desig. B See Note 5  
**DIRECT COUPLING**

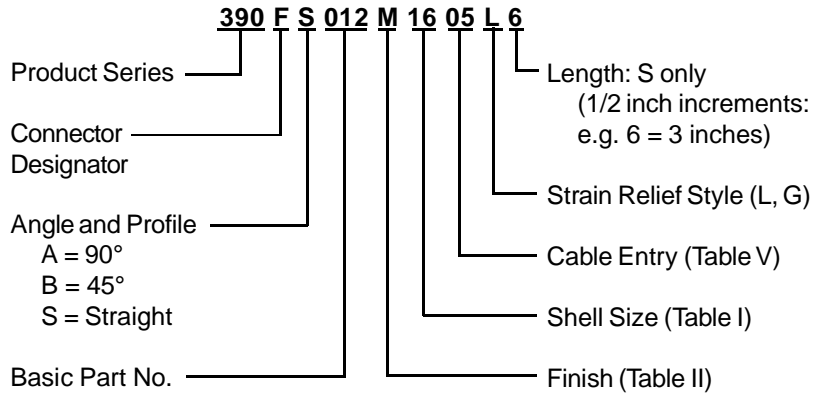

**TYPE C OVERALL  
 SHIELD TERMINATION**

Length ± .060 (1.52)  
 Min. Order Length 2.0 Inch  
 (See Note 4)

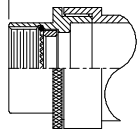

**STYLE 2  
 (STRAIGHT  
 See Note 1)**

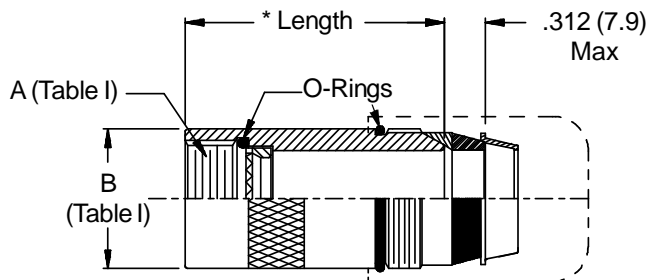

\* Length  
 ± .060 (1.52)  
 Min. Order  
 Length 1.5 Inch  
 (See Note 4)

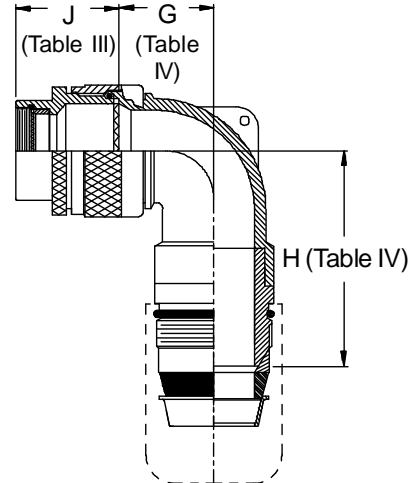
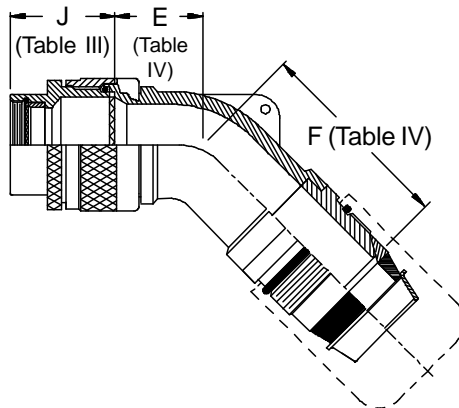

**STYLE L  
 Light Duty  
 (Table V)**

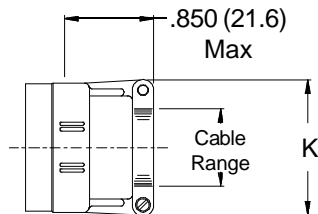

**STYLE G  
 Light Duty  
 (Table V)**

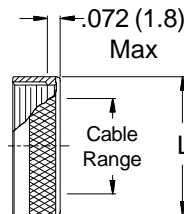

**390-012**  
**Splash-Proof EMI/RFI Cable Sealing Backshell**  
**Light-Duty with Strain Relief**  
**Type C - Direct Coupling - Low Profile**



**TABLE III: FRONT ADAPTER**

Shell Size	J Max - Conn. Designator		
	A-E-F J-H-L-S	D-B-G-K	C
08/09	1.180 (30.0)	1.250 (31.8)	
10/11	1.180 (30.0)	1.250 (31.8)	
12/13	1.180 (30.0)	1.250 (31.8)	1.735 (44.1)
14/15	1.180 (30.0)	1.250 (31.8)	1.915 (48.6)
16/17	1.380 (35.0)	1.560 (39.6)	1.915 (48.6)
18/19	1.380 (35.0)	1.560 (39.6)	1.915 (48.6)
20/21	1.380 (35.0)	1.560 (39.6)	1.915 (48.6)
22/23	1.380 (35.0)	1.560 (39.6)	1.915 (48.6)
24/25	1.380 (35.0)	1.560 (39.6)	1.915 (48.6)
28/29	1.610 (40.9)	1.560 (39.6)	1.915 (48.6)
32/33	1.610 (40.9)	1.750 (44.5)	1.915 (48.6)
36	1.610 (40.9)	1.750 (44.5)	1.915 (48.6)
40	1.610 (40.9)	2.190 (55.6)	1.915 (48.6)

See inside back cover  
 fold-out or pages 13 and  
 14 for Tables I and II.

1. When maximum cable entry (page 22) is exceeded, Style 2 will be supplied. (Function S only).
2. Metric dimensions (mm) are indicated in parentheses.
3. Cable range is defined as the accommodations range for the wire bundle or cable. Dimensions shown are not intended for inspection criteria.
4. Consult factory for shorter lengths on straight backshells.
5. When using Connector Designator B refer to pages 18 and 19 for part number development.

**TABLE IV: CABLE ENTRY**

Elbow Size	E Max	F Max	G Max	H Max
01	.457 (11.6)	1.700 (43.2)	.636 (16.2)	1.698 (43.1)
02	.457 (11.6)	1.700 (43.2)	.636 (16.2)	1.698 (43.1)
03	.630 (16.0)	1.748 (44.4)	.709 (18.0)	1.818 (46.2)
04	.692 (17.6)	1.808 (45.9)	.734 (18.6)	1.838 (46.7)
05	.755 (19.2)	1.898 (48.2)	.825 (21.0)	1.908 (48.5)
06	.848 (21.5)	1.998 (50.7)	.990 (25.1)	1.998 (50.7)
07	1.036 (26.3)	2.198 (55.8)	1.090 (27.7)	2.168 (55.1)
08	1.130 (28.7)	2.338 (59.4)	1.325 (33.7)	2.278 (57.9)
09	1.130 (28.7)	2.338 (59.4)	1.325 (33.7)	2.278 (57.9)
10	1.130 (28.7)	2.338 (59.4)	1.325 (33.7)	2.278 (57.9)

**TABLE V: CABLE ENTRY**

Dash No.	K Max	L Max	Cable Range	
			Min	Max
01	.781 (19.8)	.593 (15.1)	.062 (1.6)	.125 (3.2)
02	.968 (24.6)	.718 (18.2)	.125 (3.2)	.250 (6.4)
03	1.046 (26.6)	.843 (21.4)	.250 (6.4)	.375 (9.5)
04	1.156 (29.4)	.968 (24.6)	.375 (9.5)	.500 (12.7)
05	1.218 (30.9)	1.109 (28.2)	.500 (12.7)	.625 (15.9)
06	1.343 (34.1)	1.218 (30.9)	.625 (15.9)	.750 (19.1)
07	1.468 (37.3)	1.343 (34.1)	.750 (19.1)	.875 (22.2)
08	1.593 (40.5)	1.468 (37.3)	.875 (22.2)	1.000 (25.4)
09	1.718 (43.6)	1.593 (40.5)	1.000 (25.4)	1.125 (28.6)
10	1.843 (46.8)	1.718 (43.6)	1.125 (28.6)	1.250 (31.8)