



## PRODUCT OVERVIEW

The **D1U-W-1200** is a 1200 Watt, power-factor-corrected (PFC) front-end power supply for hot-swapping redundant systems. The main output is 12V and standby output of either 5V or 3.3V. Packaged in 1U low profile, it is designed to deliver reliable bulk power to servers, workstations, storage systems or any 12V distributed power architecture systems requiring high power density. The highly efficient electrical and thermal design with internal cooling fans supports reliable operation conditions. The D1U-W-1200 is designed to auto-recover from over-temperature faults. Status information is provided with front panel LEDs, logic signals and I<sup>2</sup>C management interface. Three units can be packaged into an optional 19" 1U power shelf to provide up to 3.6kW of power.

The **S1U-X3** is a 1U x 19" EIA Rack Mount Power Shelf designed for holding three D1U Front End Power Supplies in current sharing applications. It is intended for distributed power architecture applications in the Servers, Storage Networking and Data Communications markets. There are two lug terminal connections for #2 AWG cabling for the DC output. System connection through the I<sup>2</sup>C bus reports the performance status of the power supplies within the power shelf. Two Power Shelves can operate in parallel by an optional Shelf-to-Shelf cable, doubling the power output to the maximum capability of 7.2kW for two 12V power shelves.

## FEATURES

- RoHS compliant
- 1200W (220Vac), 900W (110Vac) Output power
- 12V Main output, 3.3V or 5V standby output
- 1U sized; dimensions 12" x 4.75" x 1.6"
- 13.2 Watts per cubic inch density
- N+1 redundancy capable, including hot-docking
- Active current sharing on main output
- Over-voltage, over-current, over-temperature protection
- Internal cooling fans
- I<sup>2</sup>C Bus Interface with status indicators
- Optional 1U x 19" power-shelf

## SELECTION GUIDE

Part Number	Power Output High Line AC	Power Output Low Line AC	Main Output	Standby Output	Airflow
D1U-W-1200-12-HC2C	1200W	900W	12V	3.3V	Back to front
D1U-W-1200-12-HA2C	1200W	900W	12V	5V	Back to front
D1U-W-1200-12-HC1C	1200W	900W	12V	3.3V	Front to back
D1U-W-1200-12-HA1C	1200W	900W	12V	5V	Front to back
Part Number	Description				
S1U-3X-16-A-12-RC	Power shelf for 12V D1U				

## INPUT CHARACTERISTICS

Parameter	Conditions	Min.	Typ.	Max.	Units
Input Voltage Operating Range	Low Line AC	90		140	Vac
	High Line AC	180		264	
Input Frequency		47	50/60	63	Hz
Turn-on Input Voltage	Ramp up	78.5		86.5	Vac
Turn-off Input Voltage	Ramp down	70.5		78	
Maximum Input Current	Low Line AC 90Vac			15	Arms
	High Line AC 180Vac			10	
Inrush Current	Cold start between 0-1msec			100	Apk
Power Factor	Output load >90%	95%			
	Output load >50%	75%			

## OUTPUT VOLTAGE CHARACTERISTICS

Output Voltage	Parameter	Conditions	Min.	Typ.	Max.	Units
12V	Voltage Set Point Accuracy			12.12		Vdc
	Line and Load Regulation		11.75		12.48	
	Ripple Voltage & Noise <sup>1</sup>	20MHz Bandwidth			120	mV p-p
	Output Current		0		98.3	A
3.3Vsb	Load Capacitance				40000	µF
	Voltage Set Point Accuracy			3.3		Vdc
	Line and Load Regulation		3.2		3.4	
	Ripple Voltage & Noise <sup>1</sup>	20MHz Bandwidth			33	mV p-p
5Vsb	Operating Range		0		6	A
	Load Capacitance				1530	µF
	Voltage Set Point Accuracy			5		Vdc
	Line and Load Regulation		4.85		5.15	
Ripple Voltage & Noise <sup>1</sup>	20MHz Bandwidth			50	mV p-p	
Operating Range		0		4	A	
Load Capacitance					1530	µF

<sup>1</sup> Ripple and noise are measured with 0.1 µF of ceramic capacitance and 2 x 270 µF of OSCON capacitance on each of the power supply outputs. The output noise requirements apply over a 0 Hz to 20 MHz bandwidth. A short coaxial cable with 50ohm scope termination is used. See Ripple Test Setup diagram.



OUTPUT CHARACTERISTICS					
Parameter	Conditions	Min.	Typ.	Max.	Units
Remote Sense			120		mV
Efficiency	220Vac		90.6		%
Output Rise Monotonicity	Overshoot less than 10% for all outputs, no voltage negative between 10% to 95% during ramp up				
Start-up Time	AC ramp up		1.5		s
	PS_On activated		150		ms
Transient Response	12V Ramp 1A/μs, 50% load step			±600	mV
	3.3Vsb Ramp 1A/μs, 50% load step			±165	
	5Vsb Ramp 1A/μs, 50% load step			±250	
Current sharing accuracy (up to 6 in parallel)	At 100% load			±10	%
Hot Swap Transients	All outputs within regulation				
Hold-up Time	Max. load, nominal Vin	20			ms

GENERAL CHARACTERISTICS					
Parameter	Conditions	Min.	Typ.	Max.	Units
Storage Temperature Range	Non-condensing	-40		70	°C
Operating Temperature Range		0		50	
Operating Humidity	Non-condensing	10		90	%
Storage Humidity		5		90	
Shock	30G non operating				
Sinusoidal Vibration	0.5G, 5 – 500 Hz operating				
MTBF	Calculated per Bellcore at Ta=30°C	200			Khrs
	Demonstrated	200			Khrs
Acoustic	ISO 7779-1999			60	dB LpAm
Safety Approvals	c-CSA-us (CSA 60950-1-03/UL 60950-1, First Edition) TUV approval (Bauart) EN 60950-1:2001				
Input Fuse	Power Supply has internal 20A/250V fast blow fuse on the AC line input				
Material Flammability	UL 94V-0				
Switching Frequency	90KHz for Boost PFC Converter 165KHz for Main Output Converter 200KHz for Standby Output Converter				
Weight	2.1kg				

PROTECTION CHARACTERISTICS						
Output Voltage	Parameter	Conditions	Min.	Typ.	Max.	Units
12V	Over-temperature	Auto-restart	55		65	°C
	Over Voltage	Latching	13		14	V
	Over Current	Latching	107		122	A
3.3Vsb	Over Voltage	Latching	3.57		4.02	V
	Over Current	Latching	6.5		8	A
5Vsb	Over Voltage	Latching	5.6		6	V
	Over Current	Latching	5		7	A

ISOLATION CHARACTERISTICS					
Parameter	Conditions	Min.	Typ.	Max.	Units
Insulation Safety Rating / Test Voltage	Input to Output - Reinforced	3000			Vrms
	Input to Chassis - Basic	1500			Vrms
Isolation	Output to Chassis				
	Output to Output				
Material Flammability	UL 94V-0				
Grounding	Main Output Return and Standby Output Return are connected internally. 100kΩ resistor parallel with 100nF capacitor is connected between Return and power supply chassis. Main Output Return should be connected to the System Chassis.				

### CONTROL SIGNALS

Status	Conditions	Description
LED	Off	No AC input to all PS
	Flashing Yellow	Power Supply Failure
	Flashing Green	Main Output Absent
	Green	Power Supply Good
I <sup>2</sup> C Registers	Status	PS-ON, PGOOD, ACOK, PS_BAD, FANFAIL, OT Warning & shutdown, AC Range
	Output Fault	12V OV, 12V UV, 12V OC, Vsb Fail, Fan1 Fail, Fan2 Fail
	12V Output	8 bit scaled output voltage
	12V	8 bit scaled output current
	Fan1 Monitor	8 bit scaled output current
	Fan2 Monitor	8 bit scaled output current

### EMISSIONS AND IMMUNITY

Characteristic	Description	Criteria
Harmonics	IEC/EN 61000-3-2	
Voltage Fluctuation and Flicker	IEC/EN 61000-3-3	
Emission Conducted	FCC 47 CFR Parts 15/CISPR 22/EN55022	Class A, 6dB margin
Emission Radiated	FCC 47 CFR Parts 15/CISPR 22/EN55022	Class A, 6dB margin
ESD	IEC/EN 61000-4-2	4kV contact discharge
		8kV operational air discharge
		15kV non-operational air discharge
Electromagnetic Field	IEC/EN 61000-4-3	
Electrical Fast Transients/Burst	IEC/EN 61000-4-4	
Surge	IEC/EN 61000-4-5	1kV/2kV, Performance Criteria B
RF Conducted Immunity	IEC/EN 61000-4-6	3 Vac, 80% AM, 1kHz, Performance Criteria A
Magnetic Immunity	IEC/EN 61000-4-8	3 A/m
Voltage dips, interruptions	IEC/EN 61000-4-11	

### RIPPLE TEST SETUP

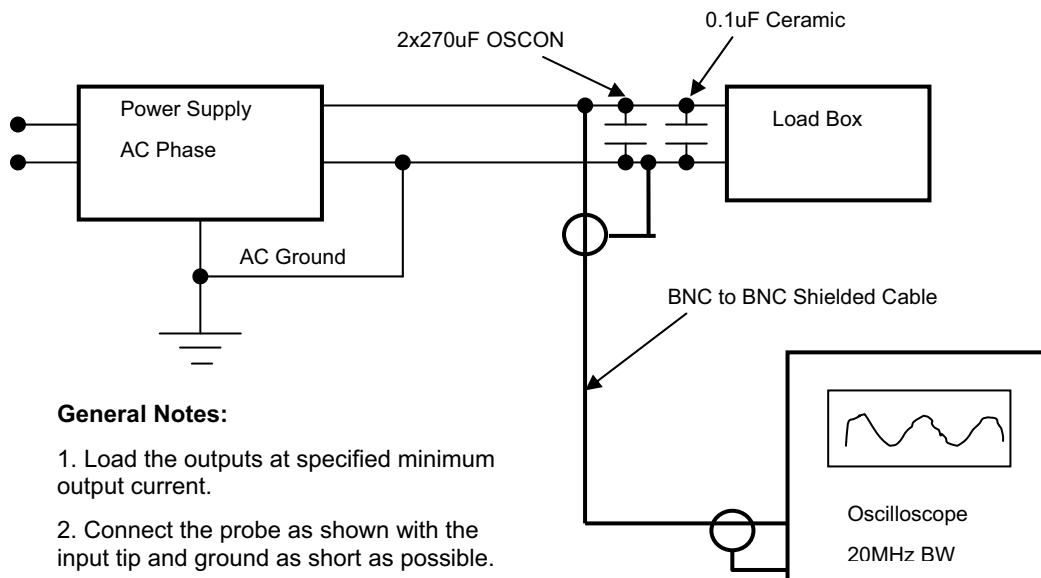

**General Notes:**

1. Load the outputs at specified minimum output current.
2. Connect the probe as shown with the input tip and ground as short as possible.
3. Take all measurements
4. Repeat the measurements with the outputs at specified maximum output current.

## OUTPUT CONNECTOR AND SIGNAL SPECIFICATION

DC and Signal Connector: Tyco Part # 1-6450132-2, or FCI PowerBlade # 51732-021

P1	P2	P3	P4	P5	P6	P7	P8	x1	x2	x3	x4	x5	x6	
V <sub>OUT</sub>	V <sub>OUT</sub>	V <sub>RTN</sub>	V <sub>RTN</sub>	V <sub>RTN</sub>	V <sub>RTN</sub>	V <sub>OUT</sub>	V <sub>OUT</sub>	AC_OK	P_GOOD	V <sub>SB</sub> RETURN	V <sub>SB</sub> RETURN	V <sub>SB</sub> +OUT	V <sub>SB</sub> +OUT	D
								SPARE	SPARE	V <sub>SB</sub> RETURN	V <sub>SB</sub> RETURN	V <sub>SB</sub> +OUT	V <sub>SB</sub> +OUT	C
								I_SHARE	I <sup>2</sup> C ADDR0	I <sup>2</sup> C ADDR1	I <sup>2</sup> C ADDR2	PS_KILL	PS_PRESENT	B
								SENSE +	SENSE -	I <sup>2</sup> C DATA	I <sup>2</sup> C CLOCK	SPARE	PS_ON	A

mate-last pins

Pin Assignment	Signal Name	Description	High Level Low Level	I Max
P1, P2, P7, P8	V <sub>OUT</sub>	Main output voltage		
P3, P4, P5, P6	V <sub>RTN</sub>	Main output voltage, return		
A1	Sense +	V <sub>OUT</sub> remote sense, positive node input, connected to the +ve load point		
A2	Sense -	V <sub>OUT</sub> remote sense, negative node input, connected to the -ve load point		
C5, C6, D5, D6	V <sub>SB</sub>	Standby voltage output		
C3, C4, D3, D4	V <sub>SB</sub> Return	Standby voltage, return, tied internally to Output Return		
B1	I_Share	Active load sharing bus	0 – 8V	-4 mA / +5 mA
D1	AC_OK	Input AC Voltage “OK” signal output (Internal pull up is 10kΩ to Vsb)	>2.4V (active, OK) <0.4V	+4 mA -2 mA
D2	P_Good	Power good signal output (Internal pull up is 10kΩ to Vsb)	>2.4V (active, Good) <0.4V	+4 mA -2 mA
B5	PS_Kill	Floating pin will turn off P/S (shorter pin, last-make and first-break contact for hot plugging). This signal overrides PS-On in disabling the Main Output	>2.1V (open, or Vsb) <0.7V (active, PS:On)	N/A
B6	PS_Present	Internally tied to Vsb return	0 V	
A6	PS_On	Internal 1K ohm pull-up to Vsb, (accepts open collector/drain drive), This signal to be pulled low to turn-on power supply	>2.1V (open, or Vsb) <0.7V (active, PS:On)	-4 mA -1 mA
A3	I <sup>2</sup> C Data	I <sup>2</sup> C serial data bus	Vsb	
A4	I <sup>2</sup> C Clock	I <sup>2</sup> C serial clock bus	Vsb	
B2	I <sup>2</sup> C ADR0	Address input 0, internal pull-up to Vsb	>2.1V, < Vsb <0.8V	±1 mA
B3	I <sup>2</sup> C ADR1	Address input 1, internal pull-up to Vsb	>2.1V, <Vsb <0.8V	±1 mA
B4	I <sup>2</sup> C ADR2	Address input 2, internal pull-up to Vsb	>2.1V, <Vsb <0.8V	±1 mA

## D1U MATING CONNECTORS

12V D1U mating connector	Press Fit		Solder <sup>2</sup>	
	Straight	Right Angle	Straight	Right Angle
MPS	N/A	N/A	N/A	36-0430032-0
FCI	51742-10802400CALF	51762-10802400CBLF	51742-10802400AALF	51762-10802400ABLF
Tyco	TBD	TBD	TBD	TBD

<sup>2</sup> Solder connector recommended for board thickness of <0.090

## CONNECTOR TO CUSTOMER SYSTEM

Signal Connector: MOLEX # 39-28-5204 OR TYCO # 281282-1

Mating Connector: MOLEX # 0039521204

Pin Assignment	Signal Name	Description	High Level Low Level	I Max
1	AC_OK1 <sup>1</sup>	Input AC Voltage 'OK' signal output for the 2nd shelf	open drain < 0.7V	- 2 mA + 4 mA
2	P_Good1 <sup>2</sup>	Power good signal output for the 2nd shelf	open drain < 0.7V	- 2 mA + 4 mA
3	PS_On1 <sup>3</sup>	Power enable for the 2nd shelf	> 2.1V (open, or Vsb) < 0.7V (active, PS:On)	- 1 mA - 4 mA
4	NOT USED			
5	AC_OK0 <sup>1</sup>	Input AC Voltage "OK" signal output for the local shelf	open drain < 0.7V	- 2 mA + 4 mA
6	P_Good0 <sup>2</sup>	Power good signal output for the local shelf	open drain < 0.7V	- 2 mA + 4 mA
7	PS_On0 <sup>3</sup>	Power enable for the local shelf	> 2.1V (open, or Vsb) < 0.7V (active, PS:On)	- 1 mA - 4 mA
8	NOT USED			
9	I <sup>2</sup> C Adr2	Address input 2	> 2.1V, < Vsb < 0.8V	± 1 mA
10	I <sup>2</sup> C Clock <sup>4</sup>	I <sup>2</sup> C serial clock bus	Vsb	
11	I <sup>2</sup> C Data <sup>4</sup>	I <sup>2</sup> C serial data bus	Vsb	
12	I_SHARE			
13	SENSE + <sup>5</sup>			
14	SENSE - <sup>5</sup>			
15	Vsb	Standby voltage output		
16	Vsb	Standby voltage output		
17	Vsb	Standby voltage output		
18	GND	GROUND		
19	GND	GROUND		
20	GND	GROUND		

All control signals are with respect to Ground. Negative currents exit the power supply.

<sup>1</sup> Signal goes low when any one of the three power supplies loses AC

<sup>2</sup> Signal goes low when any one of the three power supplies fail

<sup>3</sup> In a standalone shelf (without I<sup>2</sup>C control) Pull this pin to GND to turn on three power supplies at the same time. With I<sup>2</sup>C control, leave this signal float and Use I<sup>2</sup>C to turn on one power supply at a time.

<sup>4</sup> Recommended 10KOhm pull up resistor to host 3.3 or 5V rail

<sup>5</sup> Short Sense+ to +Vout and Sens- to GND at the point of load

## SHELF TO SHELF CONNECTION

Signal Connector: MOLEX # 39-28-5164 OR TYCO # 281281-1

Pin Assignment	Signal Name	Description	High Level Low Level	I Max
1	AC_OK1 <sup>1</sup>	Input AC Voltage 'OK' signal output for the 2nd shelf	open drain < 0.7V	- 2 mA + 4 mA
2	P_Good1 <sup>2</sup>	Power good signal output for the 2nd shelf	open drain < 0.7V	- 2 mA + 4 mA
3	PS_On1 <sup>3</sup>	Power enable for the 2nd shelf	> 2.1V (open, or Vsb) < 0.7V (active, PS:On)	- 1 mA - 4 mA
4	NOT USED			
5	NOT USED			
6	I <sup>2</sup> C Clock <sup>4</sup>	I <sup>2</sup> C serial clock bus	Vsb	
7	I <sup>2</sup> C Data <sup>4</sup>	I <sup>2</sup> C serial data bus	Vsb	
8	I_SHARE			
9	SENSE + <sup>5</sup>			
10	SENSE - <sup>5</sup>			
11	Vsb	Standby voltage output		
12	Vsb	Standby voltage output		
13	Vsb	Standby voltage output		
14	GND	GROUND		
15	GND	GROUND		
16	GND	GROUND		

**MECHANICAL DIMENSIONS - D1U-W-1200-12-Hx**

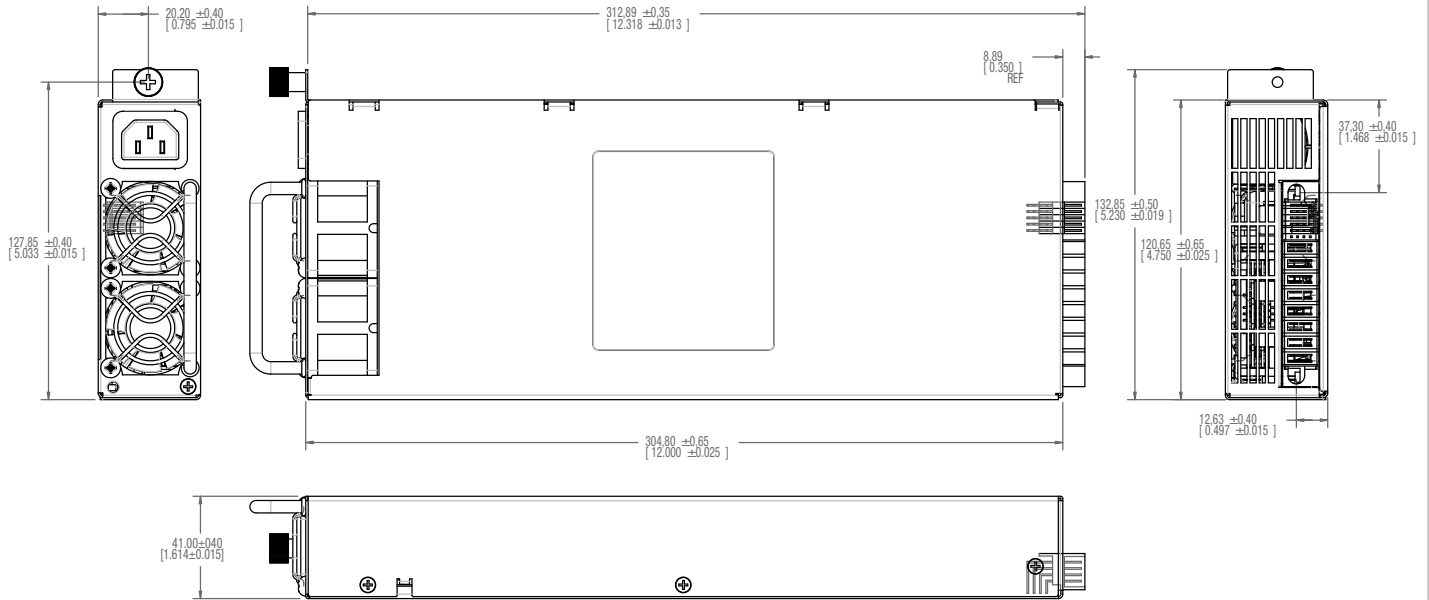

AC Input Connector: The AC input connector is standard IEC320 C14 (15A).

Dimensions: 12.00" L x 4.75" W x 1.6" H (40.7H x 120.6W x 304.90mm)

**MECHANICAL DIMENSIONS - S1U Power Shelf**

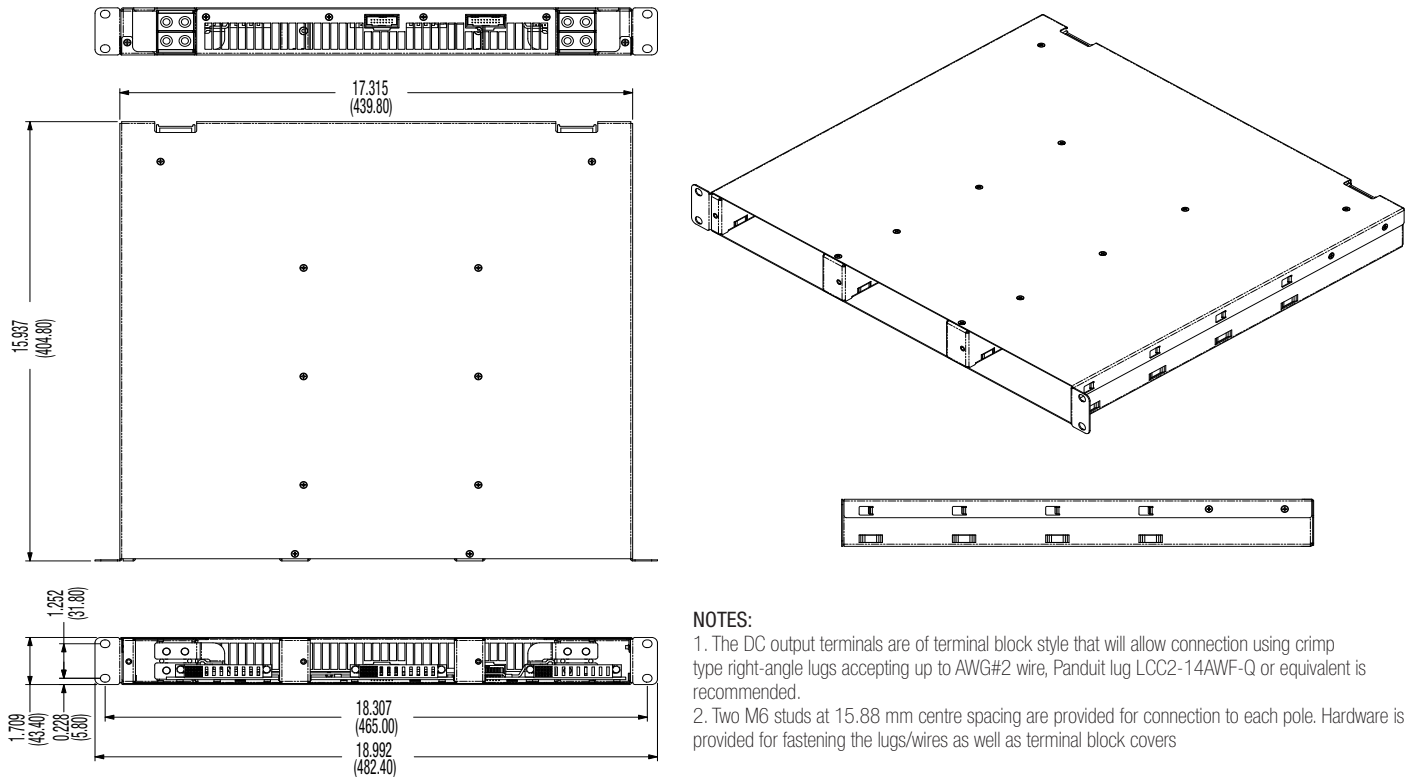

**NOTES:**

1. The DC output terminals are of terminal block style that will allow connection using crimp type right-angle lugs accepting up to AWG#2 wire, Panduit lug LCC2-14AWF-Q or equivalent is recommended.
2. Two M6 studs at 15.88 mm centre spacing are provided for connection to each pole. Hardware is provided for fastening the lugs/wires as well as terminal block covers

## S1U PIN CONNECTORS - BACK VIEW

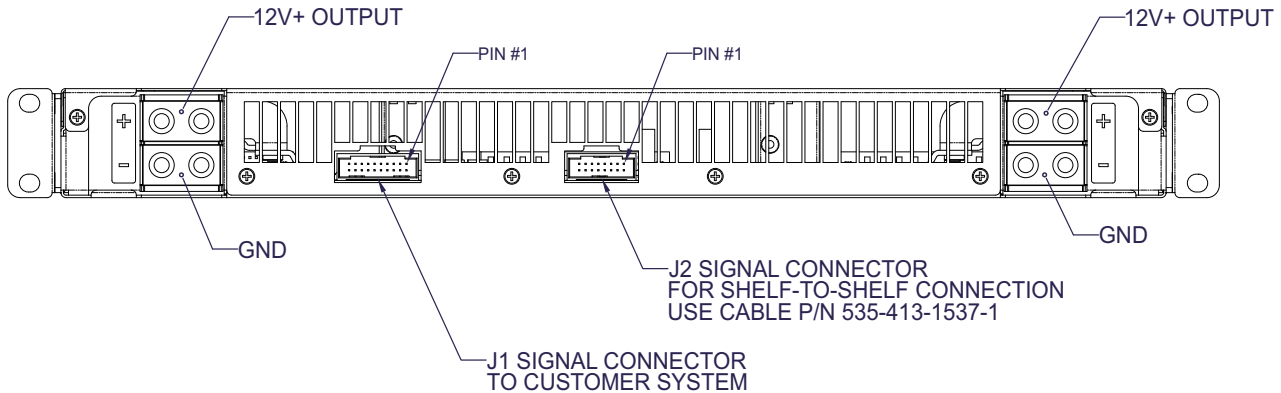

## SHELF TO SHELF CONNECTION

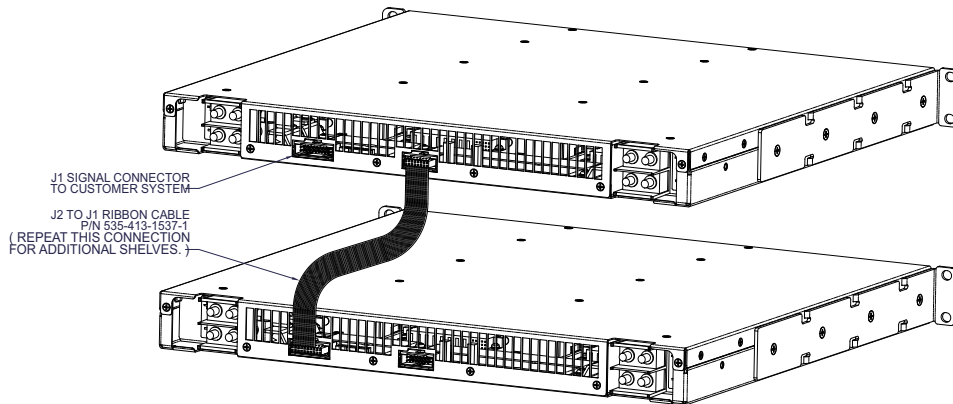

## OPTIONAL ACCESSORIES

Description	Part Number
12V D1U output connector card	D1U-12-CONC
Shelf to shelf cable	535-413-1537-1

## APPLICATION NOTES

Document Number	Description
ACAN-27	Output Connector Card
ACAN-29	D1U Communication Protocol