

Features

- 4 PIN diodes in a SOT-25 Plastic Package
- Externally Selectable Bias and RF Matching Network
- 10 – 4,000 MHz Useable Frequency Band
- + 43 dBm IP3 @ 1000 MHz (50 Ω)
- 1.0 dB Loss @ 1000 MHz (50 Ω)
- 30 dB Attenuation @ 1000 MHz (50 Ω)

Description

M/A-COM's MA4P274-1225 is a wideband, lower insertion loss, high IP3, Quad PIN Diode π Attenuator in a low-cost, surface mount SOT-25 package. Four PIN Diodes in one package reduce design parasitics and improve circuit density.

These PIN Diode Attenuators perform well where RF Signal Amplitude Control is required in 50 Ω Hand-set Circuits and 75 Ω Broadband CATV Systems. Exceptional Insertion Loss, Attenuation Range, and IP3 at <10 mA bias make these devices suitable for better power level control in RF Amplifiers.

Functional Schematic

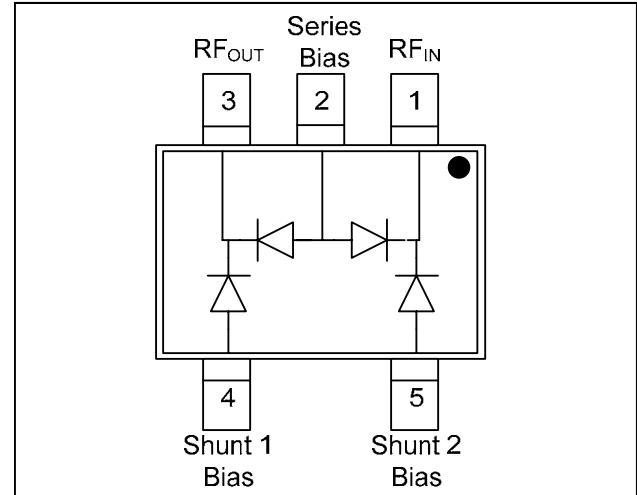

Pin Configuration

Pin No.	Function	Pin No.	Function
1	RF IN	4	Shunt 1 Bias
2	Series Bias	5	Shunt 2 Bias
3	RF OUT		

Ordering Information¹

Model No.	Package
MA4P274-1225T	Tape and Reel
MADP-000274-001SMB	Sample Board

1. Reference Application Note M513 for reel size information.

Absolute Maximum Ratings^{2,3}

Parameter	Absolute Maximum
Operating Temperature	-65 °C to +125 °C
Storage Temperature No Dissipated Power	-65 °C to +150 °C
DC Voltage at Temperature Extremes	- 100 V
DC Current	75 mA

2. Exceeding any one or combination of these limits may cause permanent damage to this device.
3. M/A-COM does not recommend sustained operation near these survivability limits.

* Restrictions on Hazardous Substances, European Union Directive 2002/95/EC.

Typical 50 Ω Performance⁴ @ 25°C using Wideband RF Circuit Design

Parameter	Test Conditions	Units	Min.	Typ.	Max.
Insertion Loss	+3 mA Series Diode Bias / 0.75 V Shunt 1 and 2 Bias 1000 MHz	dB	—	-2.0	—
Insertion Loss	+6.5 mA Series Diode Bias / 0.75 V Shunt 1 and 2 Bias 1000 MHz	dB	—	-1.0	—
Return Loss	+6.5 mA Series Diode Bias / 0.75 V Shunt 1 and 2 Bias 1000 MHz	dB	—	-10	—
Attenuation	0 mA - Series Diode Bias / 0.75 V - Shunt 1 and 2 Bias 1000 MHz	dB	—	-29	—
Input IP3	0 mA Series Diode Bias / 0.75 V Shunt 1 and 2 Bias +6.5 mA Series Diode Bias / 0.75 V Shunt 1 and 2 Bias F1 = 1000 MHz, F2 = 1100 MHz	dBm	—	43	—
		dBm	—	43	—
Input IP3	0 mA Series Diode Bias / 0.75 V Shunt 1 and 2 Bias +6.5 mA Series Diode Bias / 0.75 V Shunt 1 and 2 Bias F1 = 100 MHz, F2 = 110 MHz	dBm	—	43	—
		dBm	—	33	—
Settling Time	Within 1 dB of Final Attenuation Value 1000 MHz	μ S	—	3	—
RF C.W. Incident Power	0 - 20 V Series Diode Bias / 0.75 V Shunt 1 and 2 Bias	dBm	—	+20	—

4. Values shown include through loss calibrated out of RF test circuit.

Typical 75 Ω Performance⁵ @ +25°C using Wideband RF Circuit Design

Parameter	Test Conditions	Units	Min.	Typ.	Max.
Insertion Loss	+2 mA Series Diode Bias / 1.0 V Shunt 1 and 2 Bias +4.5 mA Series Diode Bias / 1.0 V Shunt 1 and 2 Bias 1000 MHz	dB	—	-1.1	—
		dB	—	-0.6	—
Attenuation	0 mA / Series Diode and 1.0 V Shunt 1 and 2 Bias 1000 MHz	dB	—	-27	—
Return Loss	+4.5 mA / Series Diode and 1.0 V Shunt 1 and 2 Bias 1000 MHz	dB	—	-10	—

5. Values shown include through loss calibrated out of RF test circuit.

Recommended PCB Layout

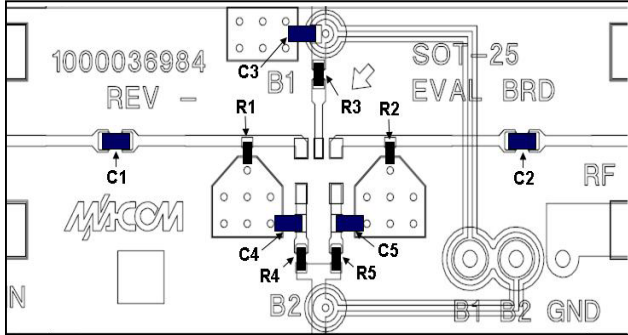

Parts List

Part	Value	Case Style	Manufacturer
C1, C2, C3, C4, C5	100 pF	0603	Murata
R1, R2, R3, R4, R5	1000 Ω	0402	Panasonic

MA4P7455-1225T Spice Model

Pin Diode Model
NLPINM2
 $I_s = 1E-14$ A
 $V_i = 0$ V
 $U_n = 900$ cm²/V-sec
 $W_i = 60$ μ m
 $R_r = 1.25$ Ohm
 $C_{min} = 0.20$ pF
 $\tau = 1.0$ usec
 $R_s = 0.1$ Ohm
 $C_{jo} = 0.27$ pF
 $V_j = 0.7$ V
 $M = 0.5$
 $F_c = 0.5$
 $I_{max} = 2.5E+6$ A/m²
 $K_f = 0$
 $A_f = 1$

Series and Shunt Diode Bias Currents as a Function of Vseries and Vshunt Voltage (Values shown are PER DIODE)

Vshunt Bias (V)	Vseries Bias (V)	Iseries Diode (mA)	Ishunt Diode (mA)
0.75	0	0.000	0.192
0.75	1	0.106	0.120
0.75	2	0.443	0.048
0.75	3	0.773	0
0.75	4	1.099	0
0.75	5	1.426	0
0.75	6	1.750	0
0.75	7	2.092	0
0.75	8	2.424	0
0.75	9	2.756	0
0.75	10	3.088	0
0.75	11	3.421	0
0.75	12	3.754	0
0.75	13	4.087	0
0.75	14	4.410	0
0.75	15	4.743	0
0.75	16	5.081	0
0.75	17	5.406	0
0.75	18	5.750	0
0.75	19	6.079	0
0.75	20	6.413	0

Schematic 10 - 1000 MHz, 50 Ω , RF Circuit ⁹

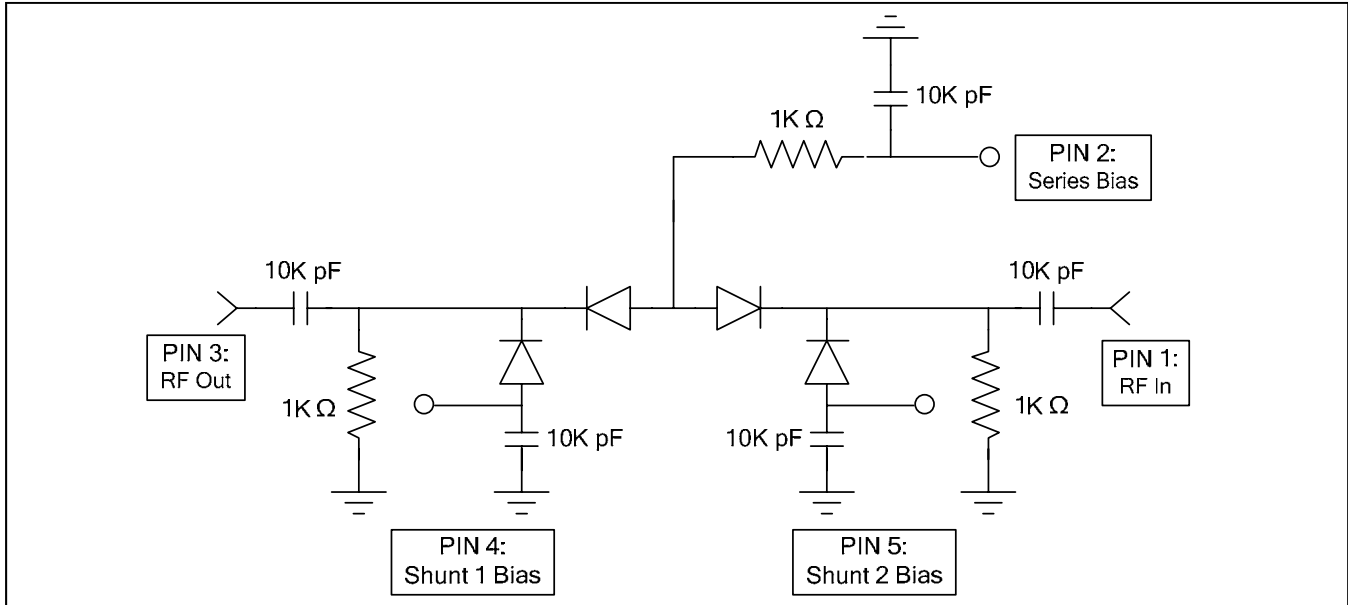

9. Keeping PIN 4 & PIN 5 as Separate Bias Points (Same V) reduces RF leakage (increases attenuation) through an otherwise connected Common Anode Bias Note.

Schematic 1 - 4 GHz, 50 Ω , RF Circuit ¹⁰

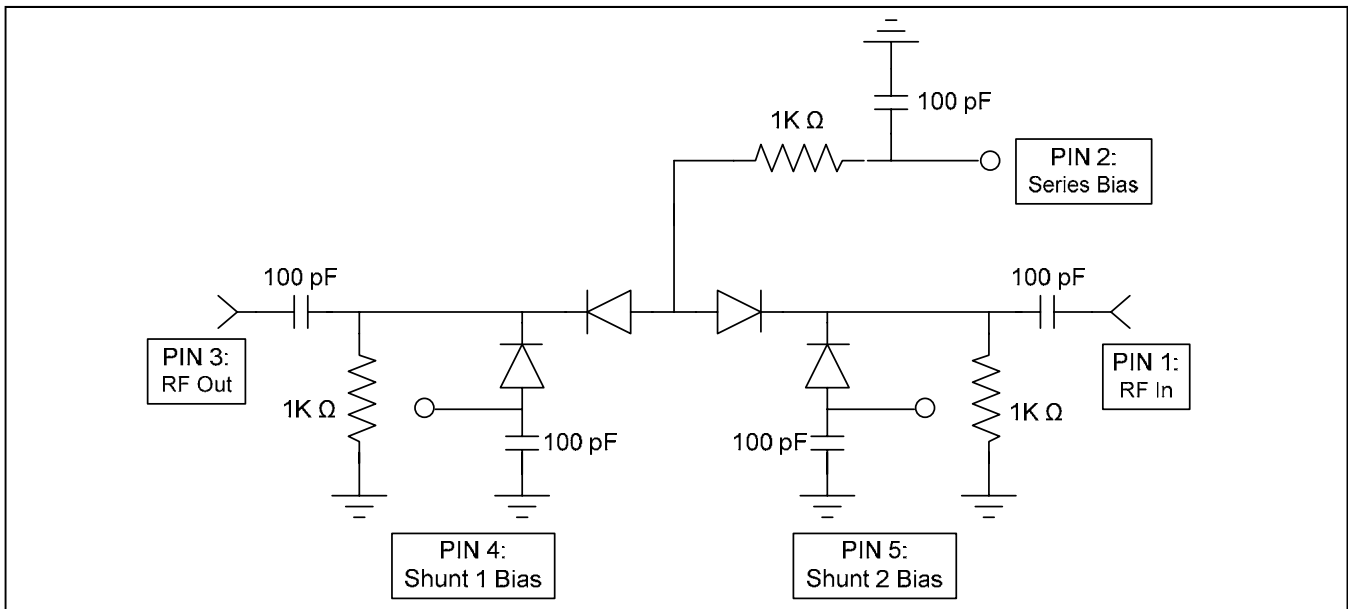

10. Keeping PIN 4 & PIN 5 as Separate Bias Points (Same V) reduces RF leakage through an otherwise connected Common Anode Bias Node.

Lumped Element Model for MA4P7455-1225 PIN Diode π Attenuator in SOT-25

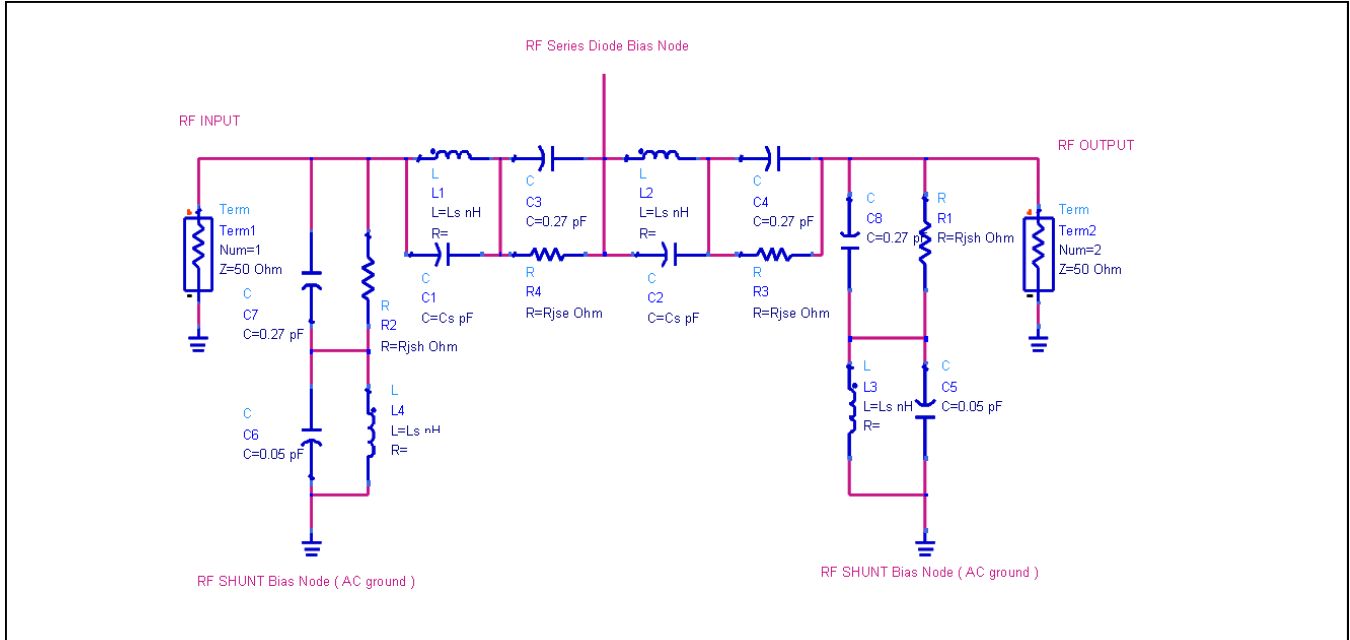

Lead Free SOT-25 †

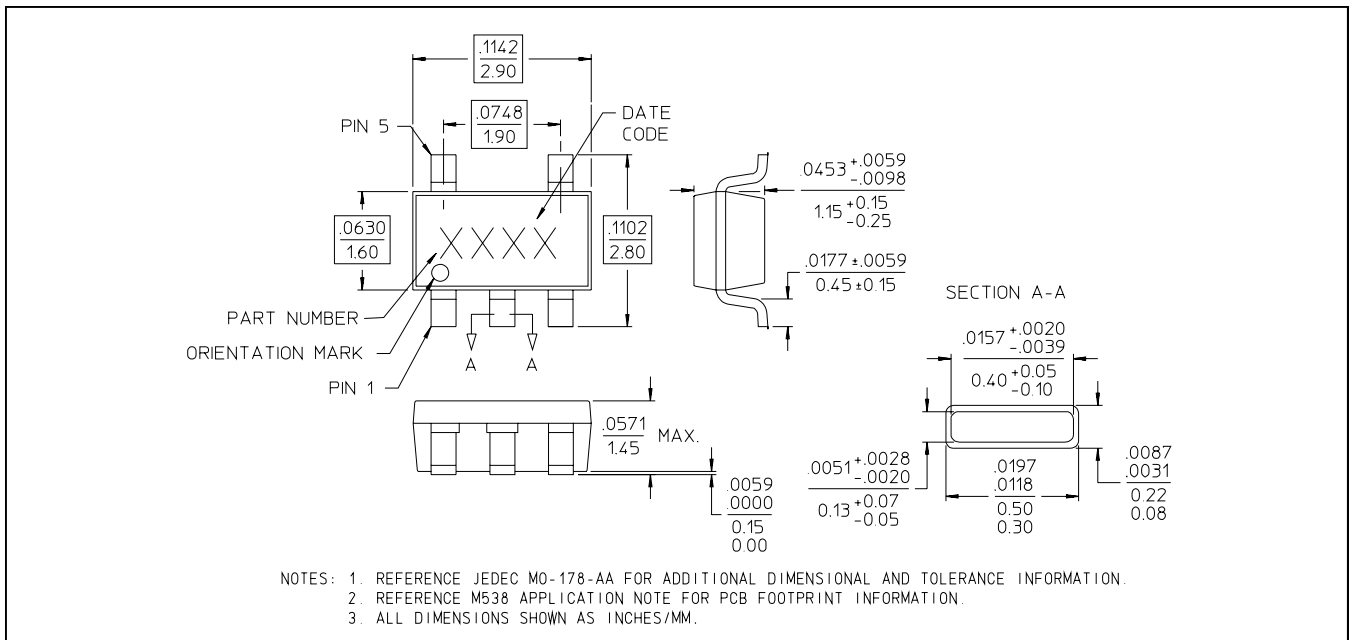

† Reference Application Note M538 for lead-free solder reflow recommendations.
Meets JEDEC moisture sensitivity level 1 requirements.

Typical Performance Curves @ +25°C, 50 - 1000 MHz, Shunt Bias = 0.75 Volts

Insertion Loss vs. Frequency

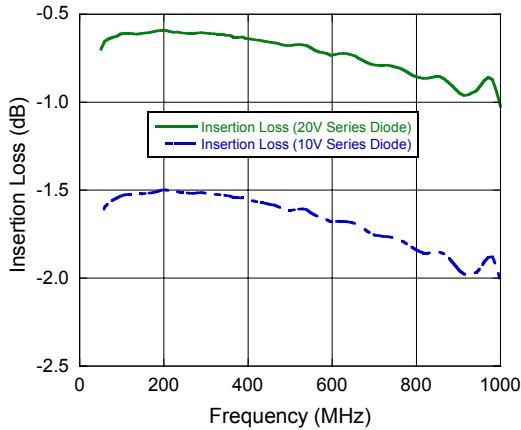

Attenuation vs. Control Voltage

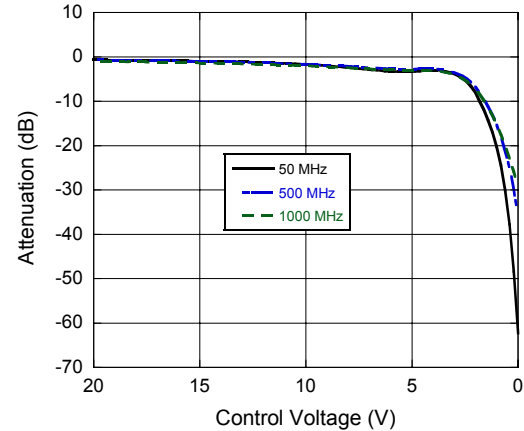

Input Return Loss vs. Control Voltage

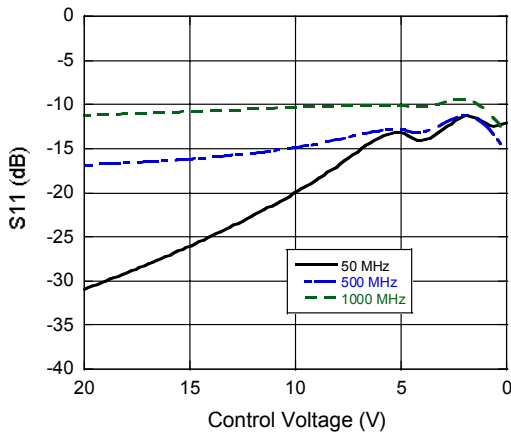

Output Return Loss vs. Control Voltage

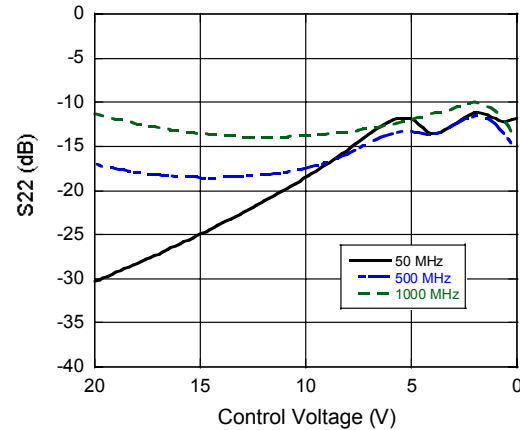

IP3 vs. Control Voltage

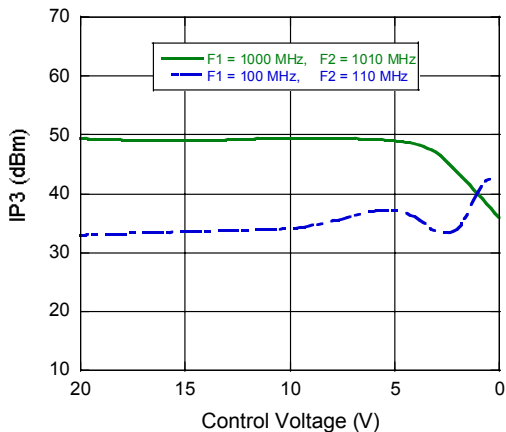

ADVANCED: Data Sheets contain information regarding a product M/A-COM is considering for development. Performance is based on target specifications, simulated results, and/or prototype measurements. Commitment to develop is not guaranteed.

PRELIMINARY: Data Sheets contain information regarding a product M/A-COM has under development. Performance is based on engineering tests. Specifications are typical. Mechanical outline has been fixed. Engineering samples and/or test data may be available. Commitment to produce in volume is not guaranteed.

- **North America** Tel: 800.366.2266 / Fax: 978.366.2266
 - **Europe** Tel: 44.1908.574.200 / Fax: 44.1908.574.300
 - **Asia/Pacific** Tel: 81.44.844.8296 / Fax: 81.44.844.8298
- Visit www.macom.com for additional data sheets and product information.

M/A-COM Inc. and its affiliates reserve the right to make changes to the product(s) or information contained herein without notice.

Typical Performance Curves @ +25°C, 1000 - 5000 MHz, Shunt Bias = 0.75 Volts

Insertion Loss vs. Frequency

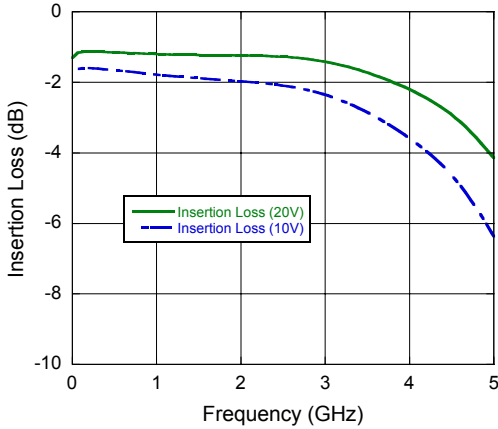

Attenuation vs. Control Voltage

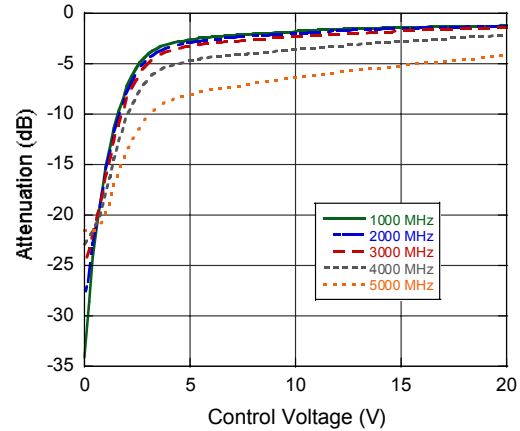

Input Return Loss vs. Control Voltage

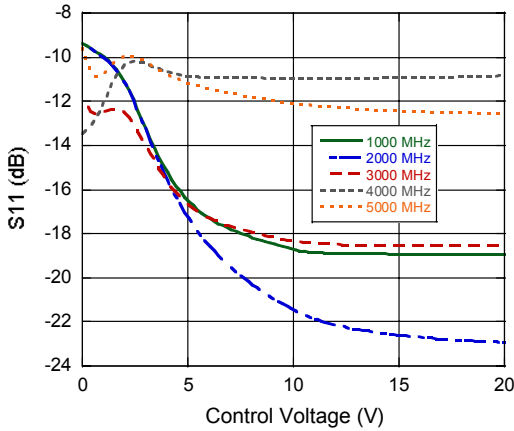

Output Return Loss vs. Control Voltage

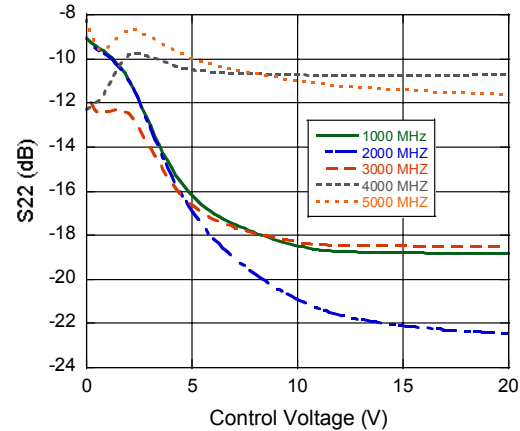

IP3 vs. Control Voltage (10 MHz Spacing)

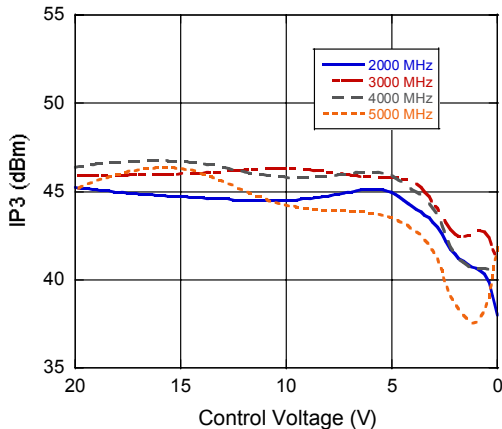

P1dB vs. Control Voltage

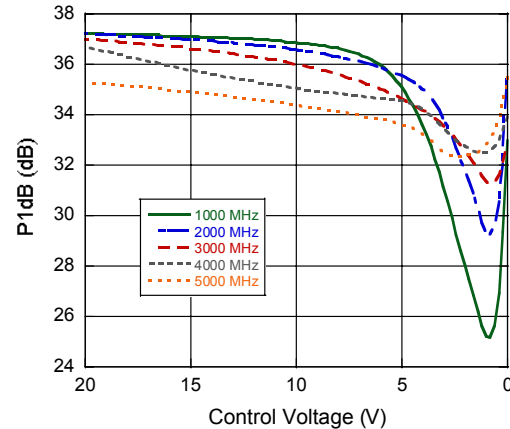

ADVANCED: Data Sheets contain information regarding a product M/A-COM is considering for development. Performance is based on target specifications, simulated results, and/or prototype measurements. Commitment to develop is not guaranteed.

PRELIMINARY: Data Sheets contain information regarding a product M/A-COM has under development. Performance is based on engineering tests. Specifications are typical. Mechanical outline has been fixed. Engineering samples and/or test data may be available. Commitment to produce in volume is not guaranteed.

- **North America** Tel: 800.366.2266 / Fax: 978.366.2266
- **Europe** Tel: 44.1908.574.200 / Fax: 44.1908.574.300
- **Asia/Pacific** Tel: 81.44.844.8296 / Fax: 81.44.844.8298

Visit www.macom.com for additional data sheets and product information.

M/A-COM Inc. and its affiliates reserve the right to make changes to the product(s) or information contained herein without notice.