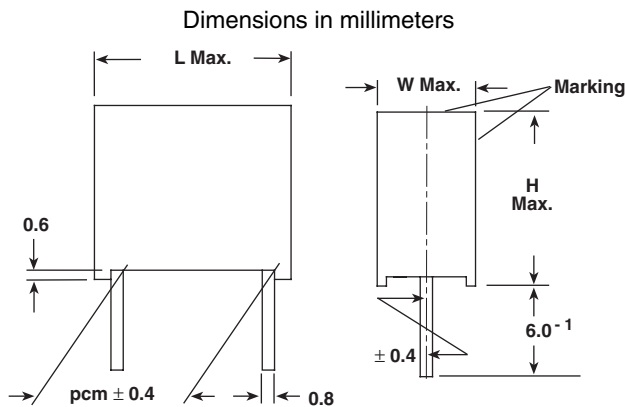

## Metallized Polycarbonate Film Capacitor

### Related Document: IEC 60384-6

**MAIN APPLICATIONS**

Storage, filter, timing and integrating circuits.

**MARKING**

 Manufacturer's logo/type/C-value/rated voltage/tolerance/  
date of manufacture

**DIELECTRIC**

Polycarbonate film

**ELECTRODES**

Vacuum deposited aluminum

**COATING**

 Flame retardant plastic case (UL-class 94 V-0), red, epoxy  
resin sealed

**CONSTRUCTION**

Extended metallized film (refer to general information)

**LEADS**

Tinned wire

**IEC TEST CLASSIFICATION**

55/100/56, according to IEC 60068

**OPERATING TEMPERATURE RANGE**

- 55°C to + 100°C

**CAPACITANCE TOLERANCES**

± 20% (M), ± 10% (K), ± 5% (J)

**RATED VOLTAGES ( $U_R$ )**

63 VDC, 100 VDC, 250 VDC, 400 VDC

**MAXIMUM PULSE RISE TIME**

PCM (mm)	Maximum Pulse Rise Time $d_v/d_t$ [V/ $\mu$ s]			
	63 VDC	100 VDC	250 VDC	400 VDC
10	17	23	38	61
15	9	13	21	33
22.5	6	8	13	20
27.5	5	6	10	16

 If the maximum pulse voltage is less than the rated voltage higher  $d_v/d_t$  values can be permitted.

**FEATURES**

 Product is completely lead (Pb)-free.  
Product is RoHS compliant.

**DERATING FOR DC AND AC. CATEGORY VOLTAGE  $U_C$** 

 At + 85°C:  $U_C = 1.0 U_R$ 

 At + 100°C:  $U_C = 0.8 U_R$ 

**CAPACITANCE RANGE**

 0.01 $\mu$ F to 10 $\mu$ F

**RoHS**  
COMPLIANT

**PERMISSIBLE AC VOLTAGES (RMS) UP TO 60HZ**

40 VAC, 63 VAC, 160 VAC, 200 VAC

**TEST VOLTAGE (ELECTRODE/ELECTRODE)**

 1.6 x  $U_R$  for 2 s

**INSULATION RESISTANCE**

 Measured at 100 VDC (63 VDC series measured at  
50 VDC) after one minute

**For  $C \leq 0.33\mu$ F and  $U_R > 100$  VDC:**

 30,000 M $\Omega$  minimum value (100,000 M $\Omega$  typical value)

**For  $C \leq 0.33\mu$ F and  $U_R \leq 100$  VDC:**

 15,000 M $\Omega$  minimum value (50,000 M $\Omega$  typical value)

**TIME CONSTANT**

 Measured at 100 VDC (63 VDC series measured at  
50 VDC) after one minute

**For  $C > 0.33\mu$ F and  $U_R > 100$  VDC:**

10,000 s minimum value (40,000 s typical value)

**For  $C > 0.33\mu$ F and  $U_R \leq 100$  VDC:**

5000 s minimum value (15,000 s typical value)

**CAPACITANCE DRIFT**

Up to + 40°C, ± 1% for a period of two years

**SELF INDUCTANCE**

~ 6 nH measured with 2mm long leads

**PULL TEST ON LEADS**

≥ 30 N in direction of leads according to IEC 60068-2-21

**BEND TEST ON LEADS**

2 bends through 90° with half of the force used in pull test

**RELIABILITY**

Operational life &gt; 300,000 h

 Failure rate < 1 FIT (40°C and 0.5 x  $U_R$ )

 For further details, please refer to the general information  
available at [www.vishay.com/doc?26033](http://www.vishay.com/doc?26033).



## DISSIPATION FACTOR TAN $\delta$

MEASURED AT	$C \leq 0.1\mu\text{F}$	$0.1\mu\text{F} < C \leq 1.0\mu\text{F}$	$C > 1.0\mu\text{F}$
1kHz	$3 \times 10^{-3}$	$3 \times 10^{-3}$	$3 \times 10^{-3}$
10kHz	$4 \times 10^{-3}$	$4 \times 10^{-3}$	—
100kHz	$10 \times 10^{-3}$	—	—
Maximum values			

CAPACITANCE	CAPACITANCE CODE	VOLTAGE CODE 06 63 VDC/40 VAC				VOLTAGE CODE 01 100 VDC/63 VAC				VOLTAGE CODE 25 250 VDC/160 VAC				VOLTAGE CODE 40 400 VDC/200 VAC			
		W	H	L	PCM	W	H	L	PCM	W	H	L	PCM	W	H	L	PCM
0.01 $\mu\text{F}$	- 310	—	—	—	—	—	—	—	—	—	—	—	—	4.0	9.0	13.0	10
0.015 $\mu\text{F}$	- 315	—	—	—	—	—	—	—	—	—	—	—	—	4.0	9.0	13.0	10
0.022 $\mu\text{F}$	- 322	—	—	—	—	—	—	—	—	4.0	9.0	13.0	10	4.0	9.0	13.0	10
0.033 $\mu\text{F}$	- 333	—	—	—	—	—	—	—	—	4.0	9.0	13.0	10	5.5	10.5	13.0	10
0.047 $\mu\text{F}$	- 347	—	—	—	—	—	—	—	—	4.0	9.0	13.0	10	5.5	10.5	18.0	15
0.068 $\mu\text{F}$	- 368	—	—	—	—	4.0	9.0	13.0	10	5.5	10.5	13.0	10	5.5	10.5	18.0	15
0.1 $\mu\text{F}$	- 410	—	—	—	—	4.0	9.0	13.0	10	5.5	10.5	18.0	15	6.5	12.5	18.0	15
0.15 $\mu\text{F}$	- 415	—	—	—	—	5.5	10.5	13.0	10	5.5	10.5	18.0	15	8.5	14.5	18.0	15
0.22 $\mu\text{F}$	- 422	4.0	9.0	13.0	10	6.5	11.5	13.0	10	6.5	12.5	18.0	15	7.5	15.5	26.5	22.5
0.33 $\mu\text{F}$	- 433	4.5	9.5	13.0	10	5.5	10.5	18.0	15	7.5	13.5	18.0	15	8.5	16.5	26.5	22.5
0.47 $\mu\text{F}$	- 447	5.5	10.5	13.0	10	6.5	12.5	18.0	15	7.5	15.5	26.5	22.5	10.5	18.5	26.5	22.5
0.68 $\mu\text{F}$	- 468	5.5	10.5	18.0	15	7.5	13.5	18.0	15	8.5	16.5	26.5	22.5	11.5	20.5	31.5	27.5
1.0 $\mu\text{F}$	- 510	6.5	12.5	18.0	15	8.5	14.5	18.0	15	8.5	16.5	26.5	22.5	13.5	23.5	31.5	27.5
1.5 $\mu\text{F}$	- 515	7.5	13.5	18.0	15	7.5	15.5	26.5	22.5	11.5	20.5	31.5	27.5	—	—	—	—
2.2 $\mu\text{F}$	- 522	8.5	14.5	18.0	15	8.5	16.5	26.5	22.5	11.5	20.5	31.5	27.5	—	—	—	—
3.3 $\mu\text{F}$	- 533	7.5	15.5	26.5	22.5	10.5	18.5	26.5	22.5	13.5	23.5	31.5	27.5	—	—	—	—
4.7 $\mu\text{F}$	- 547	8.5	16.5	26.5	22.5	11.5	20.5	31.5	27.5	16.5	29.5	31.5	27.5	—	—	—	—
6.8 $\mu\text{F}$	- 568	10.5	18.5	26.5	22.5	13.5	23.5	31.5	27.5	—	—	—	—	—	—	—	—
10.0 $\mu\text{F}$	- 610	11.5	20.5	31.5	27.5	15.0	24.5	31.5	27.5	—	—	—	—	—	—	—	—

Further C-values upon request

## RECOMMENDED PACKAGING

LETTER CODE	TYPE OF PACKAGING	HEIGHT (H) (mm)	REEL DIAMETER (mm)	ORDERING CODE EXAMPLES	PCM 10	PCM 15	PCM 22.5 - 27.5
D	AMMO	16.5	S*	MKC 1862-310/405-D	X	X	—
G	AMMO	18.5	S*	MKC 1862-310/405-G	X	X	—
F	REEL	16.5	350	MKC 1862-310/405-F	X	X	—
W	REEL	18.5	350	MKC 1862-310/405-W	X	X	—
V	REEL	18.5	500	MKC 1862-522/255-V	—	X	X
G	AMMO	18.5	L*	MKC 1862-522/255-G	—	—	X
—	BULK	—	—	MKC 1862-522/255	X	X	X

\*S - box size 55 x 210 x 340mm (W x H x L)

\*L - box size 60 x 360 x 510mm (W x H x L)

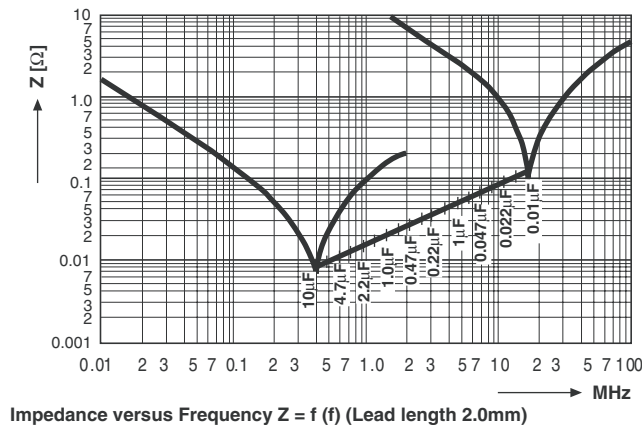
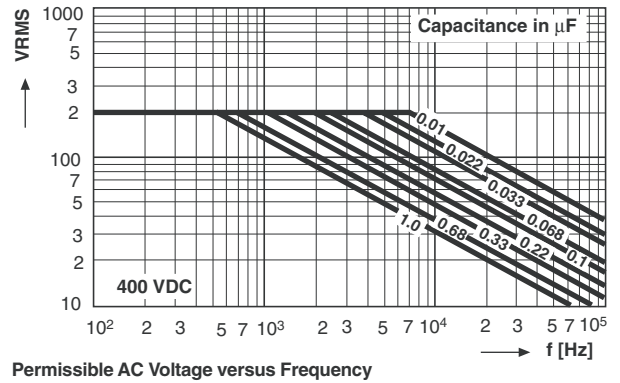
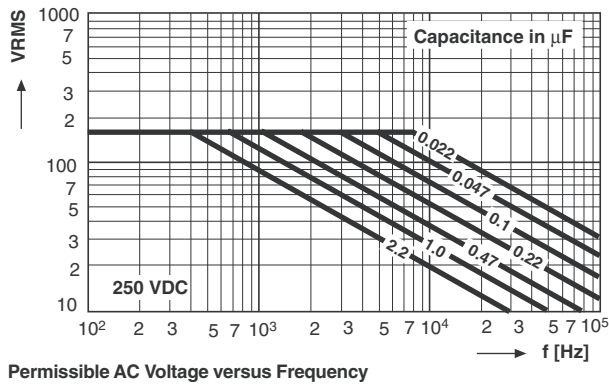
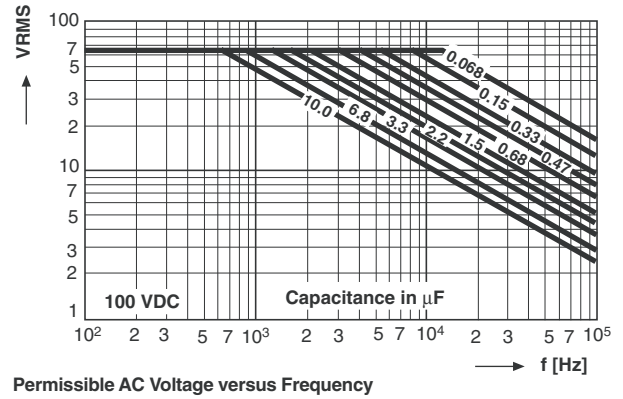
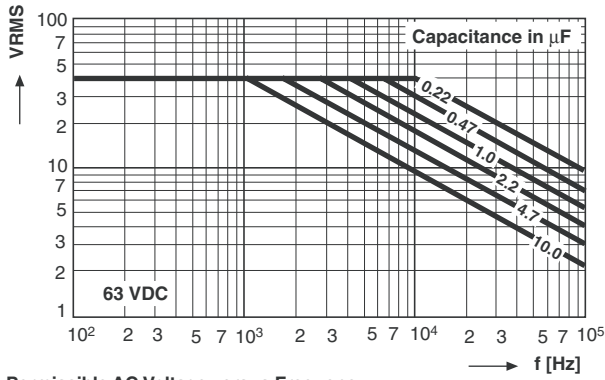



## Disclaimer

All product specifications and data are subject to change without notice.

Vishay Intertechnology, Inc., its affiliates, agents, and employees, and all persons acting on its or their behalf (collectively, "Vishay"), disclaim any and all liability for any errors, inaccuracies or incompleteness contained herein or in any other disclosure relating to any product.

Vishay disclaims any and all liability arising out of the use or application of any product described herein or of any information provided herein to the maximum extent permitted by law. The product specifications do not expand or otherwise modify Vishay's terms and conditions of purchase, including but not limited to the warranty expressed therein, which apply to these products.

No license, express or implied, by estoppel or otherwise, to any intellectual property rights is granted by this document or by any conduct of Vishay.

The products shown herein are not designed for use in medical, life-saving, or life-sustaining applications unless otherwise expressly indicated. Customers using or selling Vishay products not expressly indicated for use in such applications do so entirely at their own risk and agree to fully indemnify Vishay for any damages arising or resulting from such use or sale. Please contact authorized Vishay personnel to obtain written terms and conditions regarding products designed for such applications.

Product names and markings noted herein may be trademarks of their respective owners.