

Resistive Sensors Linear Type (Exclusively Used to Detect The Angle of Vehicle Head Lights)

RD7 Series

Exclusive for headlight angle detection with high accuracy and space-saving design.

Magnetic Sensor

Piezo Sensor

Resistive Sensor

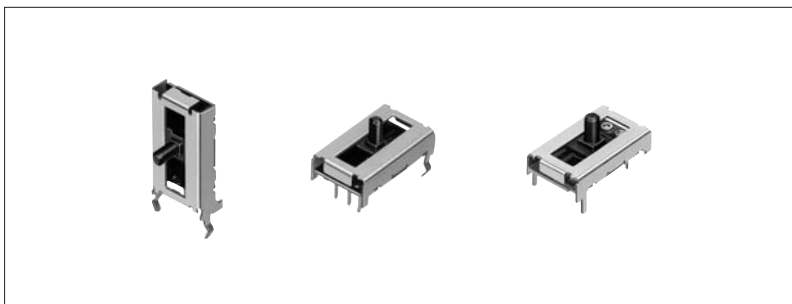

Features

- Advanced printing technology ensures high-precision linearity.
- Space saving design contribute to lighter weight and smaller size of the set.
- Operational in temperatures up to 105°C.

Applications

- Exclusively used to detect the angle of vehicle headlights

Product Line

Travel (mm)	Mounting method	Total resistance (kΩ)	Rated voltage	Linearity	Model No.	Minimum Units Per Pack (pcs.) ※	Drawing No.
8	Vertical type	4.7	12V DC	±1%	RD708A029A	2,000	1
	Horizontal type	5			RD7081015A	1,500	2
9					RD7091008A	1,800	3
12	Vertical type	2.2			RD712A028A	2,000	1
	Horizontal type	10			RD7121008A	1,800	4

Note

※ The minimum packing unit is the basic unit quantity of your order. Please place purchase orders in integer multiples of the minimum packing unit. Please contact us for export packaging details.

Dimensions



Unit:mm

No.	Photo	Style												
1	<p>RD708A RD712A</p>	<table border="1"> <thead> <tr> <th>Dimension Model</th> <th>S</th> <th>A</th> <th>B</th> </tr> </thead> <tbody> <tr> <td>RD708A</td> <td>8</td> <td>15</td> <td>3.4</td> </tr> <tr> <td>RD712A</td> <td>12</td> <td>19</td> <td>3.8</td> </tr> </tbody> </table>	Dimension Model	S	A	B	RD708A	8	15	3.4	RD712A	12	19	3.8
Dimension Model	S	A	B											
RD708A	8	15	3.4											
RD712A	12	19	3.8											

For other product specifications, see P.30

Dimensions

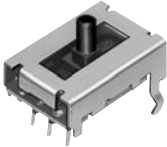
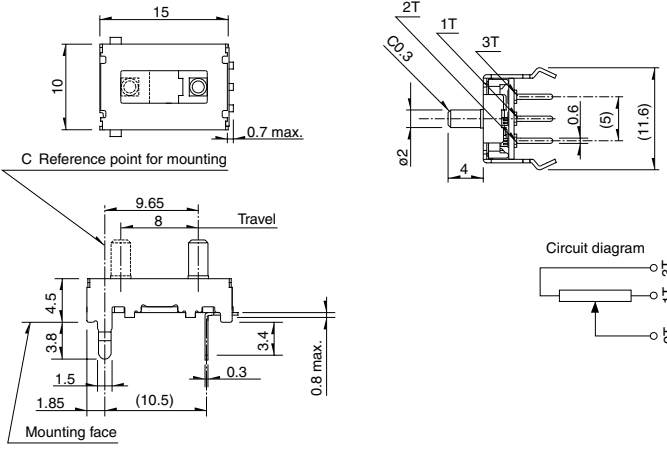
Unit:mm

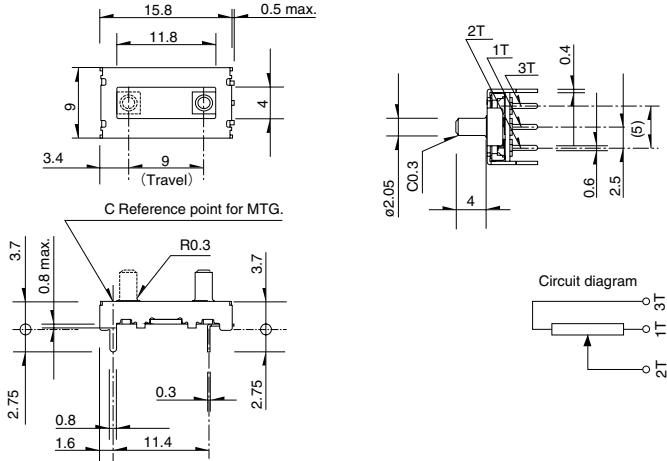
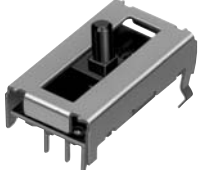
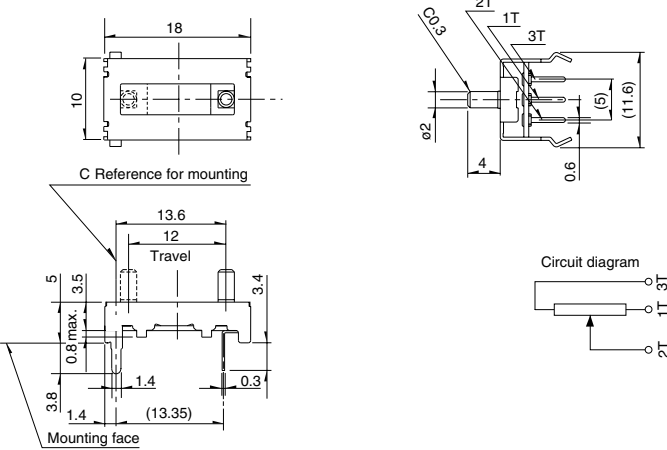
No.	Photo	Style
2		
3		
4		

Note

For linearity, various specifications will be available, depending on the applications. Please consult with us when placing your orders.

Magnetic Sensor
 Piezo Sensor
 Resistive Sensor

Product Specifications

Item	Style	Rotary type			Linear type	
	Model	RDC40	RDC501/RDC502/ RDC503/RDC506	RDC80	RDC10	RD7
Operating temperature range		-30°C to +80°C	-40°C to +120°C		-30°C to +85°C	-40°C to +105°C
Electric performance	Total resistance tolerance	±30%				±20%
	Resistance taper	Linear				
	Rated voltage	5V DC				12V DC
	Max. operating voltage	18V DC	16V DC		5V DC	18V DC
	Linearity	±1%	±2%	±3%	±0.5%	±1%
Mechanical performance	Effective variable range	13rotations	320°	330° (1-phase) 360° (2-phase)	S (travel) -2mm	S (travel)
	Rotational angle	—	(Without stopper)		—	
	Rotational torque	2mN·m max.		10mN·m max.	—	
	Operating force	—			0.25N max.	2N less.
Durability	100,000cycles	●	—	●	—	●
	200,000cycles	—	—	—	●	—
	1,000,000cycles	—	●	—	—	—

Method for Regulating the Linearity

