

## Six Channel *ActivePath*<sup>TM</sup> Power Management IC

### FEATURES

- *ActivePath*<sup>TM</sup> Li+ Charger with System Power Selection
- Four Integrated Regulators:
  - 1.3A High Efficiency Step-Down DC/DC
  - 1.0A High Efficiency Step-Down DC/DC
  - 0.55A High Efficiency Step-Down DC/DC
  - 30V Step-Up DC/DC for up to 7s x 3p WLEDs
- I<sup>2</sup>C<sup>TM</sup> Serial Interface
- Minimal External Components
- Compatible with USB or AC-Adapter Charging
- 5x5mm, Thin-QFN (TQFN55-40) Package
  - Only 0.75mm Height
  - RoHS Compliant

### APPLICATIONS

- Personal Navigation Devices
- Portable Media Players
- Smart Phones

### GENERAL DESCRIPTION

The patent-pending ACT8828 is a complete, cost effective, highly-efficient *ActivePMU*<sup>TM</sup> power management solution that is ideal for a wide range of high performance portable handheld applications such as personal navigation devices (PNDs). This device integrates the *ActivePath* complete battery charging and management system with four power supply channels.

The *ActivePath* architecture automatically selects the best available input supply for the system. If the external input source is not present or the system load current is more than the input source can provide, the *ActivePath* supplies additional current from the battery to the system. The charger is a complete, thermally-regulated, stand-alone single-cell linear Li+ charger that incorporates an internal power MOSFET.

REG1, REG2, and REG3 are three independent, fixed-frequency, current-mode step-down DC/DC converters that output 1.3A, 1.0A, and 0.55A, respectively. REG4 is a fixed-frequency, step-up DC/DC converter that safely and efficiently biases strings of up to 7 white-LEDs (up to a total of 21 LEDs) for display backlight applications. Finally, an I<sup>2</sup>C serial interface provides programmability for the DC/DC converters.

The ACT8828 is available in a tiny 5mm x 5mm 40-pin Thin-QFN package that is just 0.75mm thin.

### SYSTEM BLOCK DIAGRAM

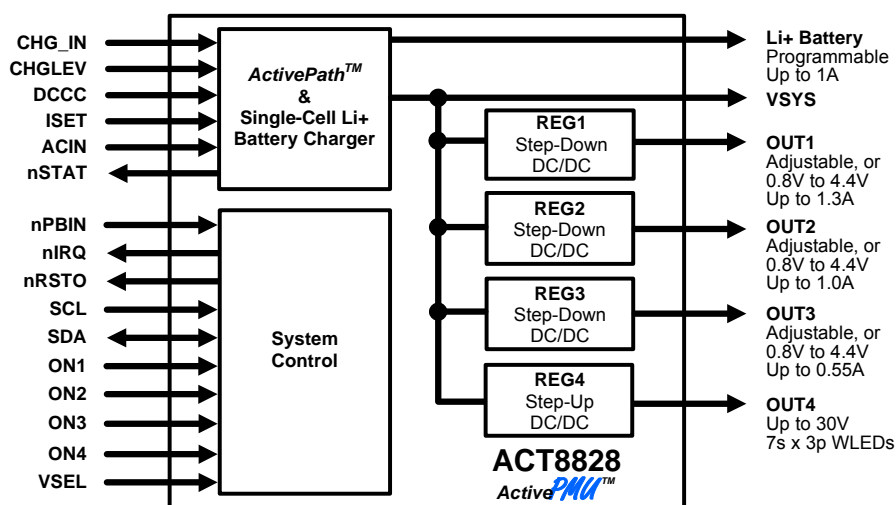

## TABLE OF CONTENTS

<b>GENERAL INFORMATION .....</b>	<b>P. 01</b>
Functional Block Diagram .....	p. 03
Ordering Information .....	p. 04
Pin Configuration.....	p. 04
Pin Descriptions .....	p. 05
Absolute Maximum Ratings.....	p. 07
<b>SYSTEM MANAGEMENT .....</b>	<b>P. 08</b>
Register Descriptions .....	p. 08
I <sup>2</sup> C Interface Electrical Characteristics .....	p. 09
Electrical Characteristics .....	p. 10
Register Descriptions .....	p. 11
Typical Performance Characteristics.....	p. 12
Functional Description.....	p. 13
<b>STEP-DOWN DC/DC CONVERTERS .....</b>	<b>P. 17</b>
Electrical Characteristics .....	p. 17
Typical Performance Characteristics.....	p. 20
Register Descriptions .....	p. 22
Functional Description.....	p. 28
<b>STEP-UP DC/DC CONVERTERS .....</b>	<b>P. 31</b>
Electrical Characteristics .....	p. 31
Typical Performance Characteristics.....	p. 32
Register Descriptions .....	p. 33
Functional Description.....	p. 35
<b>ActivePath™ CHARGER .....</b>	<b>P. 37</b>
Electrical Characteristics .....	p. 37
Typical Performance Characteristics.....	p. 39
Functional Description.....	p. 41
<b>PACKAGE INFORMATION .....</b>	<b>P. 49</b>

## FUNCTIONAL BLOCK DIAGRAM

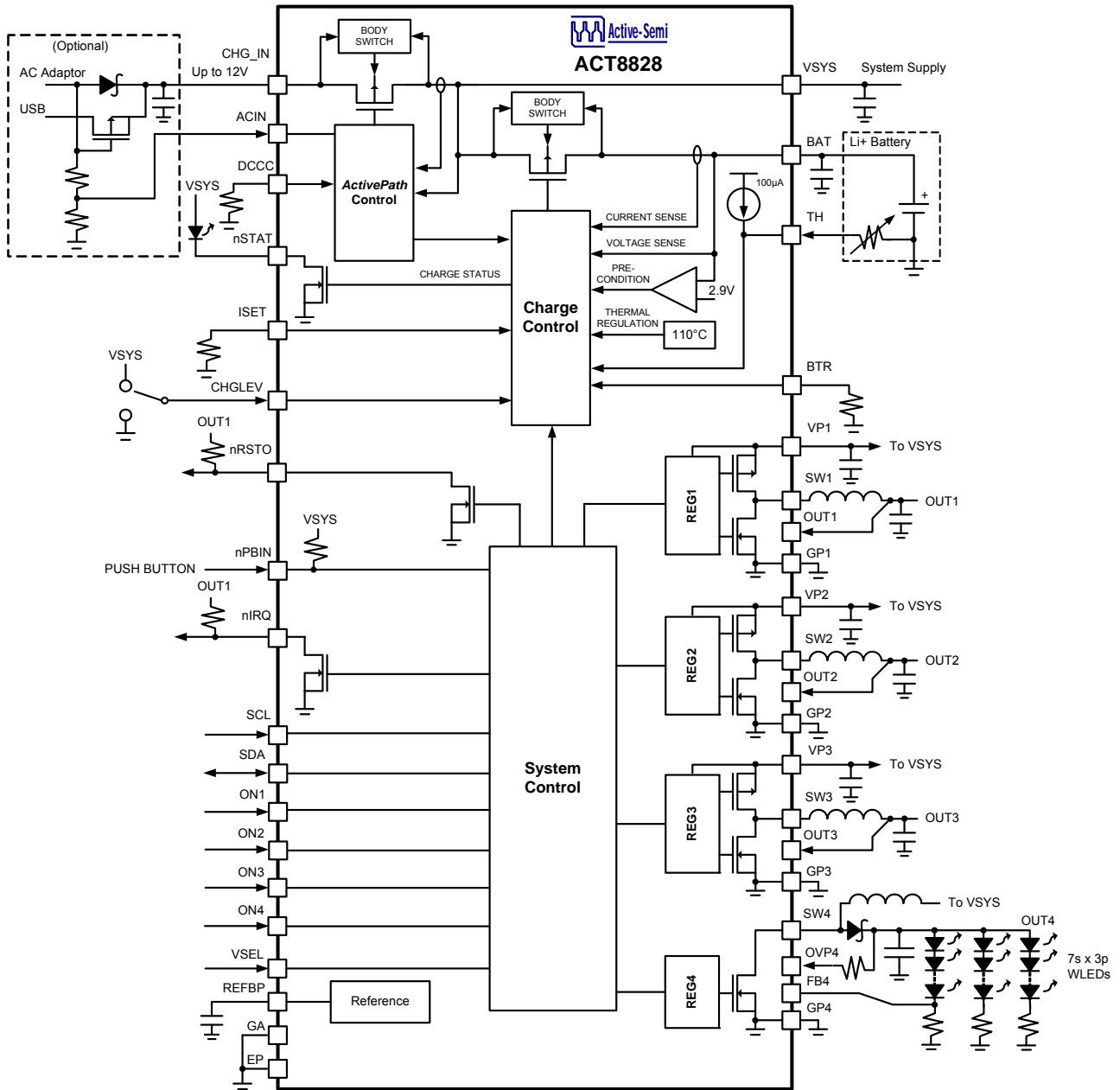

## ORDERING INFORMATION<sup>①</sup>

PART NUMBER	$V_{OUT1}/V_{STBY1}$ <sup>②</sup>	$V_{OUT2}/V_{STBY2}$	$V_{OUT3}/V_{STBY3}$	CONTROL SEQUENCE <sup>③</sup>
ACT8828QJ1D2-T	1.2V/1.2V	1.9V/1.9V	3.3V/3.3V	Sequence A
ACT8828QJ250-T	3.3V/3.3V	1.85V/1.85V	1.25V/1.25V	Sequence B
ACT8828QJ3B9-T	1.2V/1.2V	1.8V/1.8V	3.3V/3.3V	Sequence C

PACKAGING DETAILS	PACKAGE	PINS	TEMPERATURE RANGE	PACKING
ACT8828QJ###-T	TQFN55-40	40	-40°C to +85°C	TAPE & REEL

①: All Active-Semi components are RoHS Compliant and with Pb-free plating unless specified differently. The term Pb-free means semiconductor products that are in compliance with current RoHS (Restriction of Hazardous Substances) standards.

②: To select  $V_{STBYx}$  as an output regulation voltage of REGx, tie VSEL to VSYS or a logic high.

③: Refer to the Control Sequence section for more information.

## PIN CONFIGURATION

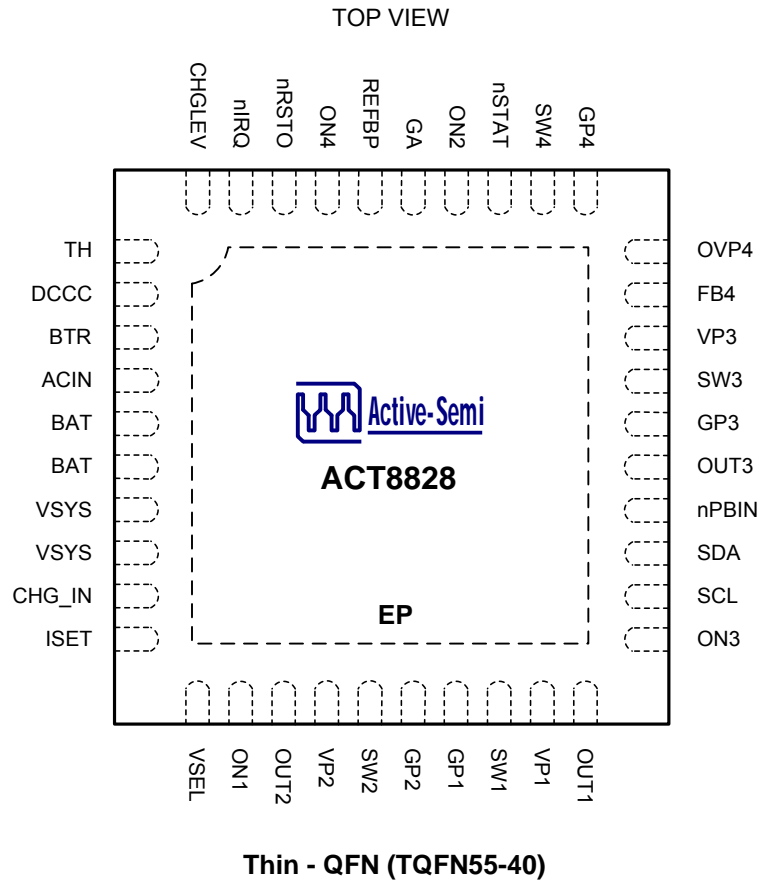

## PIN DESCRIPTIONS

PIN	NAME	DESCRIPTION
1	TH	Temperature Sensing Input. Connect to battery thermistor. TH is pulled up with a 100 $\mu$ A current internally. See the <i>Battery Temperature Monitoring</i> section for more information.
2	DCCC	Dynamic Charging Current Control. Connect a resistor to set the dynamic charging current control point. A internal 100 $\mu$ A current source sets up a voltage that is used to compare with VSYS and dynamically scale the charging current to maintain VSYS regulation. See the <i>Dynamic Charge Current Control</i> section for more information.
3	BTR	Safety Timer Program Pin. The resistance between this pin and GA determines the timers timeout values. See the <i>Charging Safety Timers</i> section for more information.
4	ACIN	AC Adaptor Detect. Detects presence of a wall adaptor and automatically adjusts the charge current to the maximum charge current level. Do not leave ACIN floating.
5, 6	BAT	Battery Charger Output. Connect this pin directly to the battery anode (+ terminal)
7, 8	VSYS	System Output Pin. Bypass to GA with a 10 $\mu$ F or larger ceramic capacitor.
9	CHG_IN	Power Input for the Battery Charger. Bypass CHG_IN to GA with a capacitor placed as close to the IC as possible. The battery charger are automatically enabled when a valid voltage is present on CHG_IN.
10	ISET	Charge Current Set. Program the maximum charge current by connecting a resistor (R <sub>ISET</sub> ) between ISET and GA. See the <i>Charger Current Programming</i> section for more information.
11	VSEL	Step-Down DC/DCs Output Voltage Selection. Drive to logic low to select default output voltage. Drive to logic high to select secondary output voltage. See the <i>Output Voltage Selection Pin</i> section for more information.
12	ON1	Independent Enable Control Input for REG1. Drive ON1 to VSYS or to a logic high for normal operation, drive to GA or a logic low to disable REG1. Do not leave ON1 floating.
13	OUT2	Output Feedback Sense for REG2. Connect this pin directly to the output node to connect the internal feedback network to the output voltage.
14	VP2	Power Input for REG2. Bypass to GP2 with a high quality ceramic capacitor placed as close as possible to the IC.
15	SW2	Switching Node Output for REG2. Connect this pin to the switching end of the inductor.
16	GP2	Power Ground for REG2. Connect GA, GP1, GP2, GP3, and GP4 together at a single point as close to the IC as possible.
17	GP1	Power Ground for REG1. Connect GA, GP1, GP2, GP3, and GP4 together at a single point as close to the IC as possible.
18	SW1	Switching Node Output for REG1. Connect this pin to the switching end of the inductor.
19	VP1	Power Input for REG1. Bypass to GP1 with a high quality ceramic capacitor placed as close as possible to the IC.
20	OUT1	Output Feedback Sense for REG1. Connect this pin directly to the output node to connect the internal feedback network to the output voltage.
21	ON3	Enable Control Input for REG3. Drive ON3 to a logic high for normal operation, drive to GA or a logic low to disable REG3. Do not leave ON3 floating.
22	SCL	Clock Input for I <sup>2</sup> C Serial Interface.
23	SDA	Data Input for I <sup>2</sup> C Serial Interface. Data is read on the rising edge of SCL.

**PIN DESCRIPTIONS CONT'D**

PIN	NAME	DESCRIPTION
24	nPBIN	Master Enable Input. Drive nPBIN to GA through a 100kΩ resistor to enable the IC, drive nPBIN directly to GA to assert a Hard-Reset condition. Refer to the <i>System Startup &amp; Shutdown</i> section for more information. nPBIN is internally pulled up to VSYS through a 50kΩ resistor.
25	OUT3	Output Feedback Sense for REG3. Connect this pin directly to the output node to connect the internal feedback network to the output voltage.
26	GP3	Power Ground for REG3. Connect GA, GP1, GP2, GP3, and GP4 together at a single point as close to the IC as possible.
27	SW3	Switching Node Output for REG3. Connect this pin to the switching end of the inductor.
28	VP3	Power Input for REG3. Bypass to GP3 with a high quality ceramic capacitor placed as close as possible to the IC.
29	FB4	Feedback Sense for REG4. Connect this pin to the LED string current sense resistor to sense the LED current.
30	OVP4	Over-Voltage Protection Input for REG4. Connect this pin to the output node through a 10kΩ resistor to sense and prevent over-voltage conditions.
31	GP4	Power Ground for REG4. Connect GP4 directly to a power ground plane. Connect GA, GP1, GP2, GP3, and GP4 together at a single point as close to the IC as possible.
32	SW4	Switching Node Output for REG4. Connect this pin to the switching end of the inductor.
33	nSTAT	Active-Low Open-Drain Charger Status Output. nSTAT has a 5mA (typ) current limit, allowing it to directly drive an indicator LED without additional external components. To generate a logic-level output, connect nSTAT to an appropriate supply voltage (typically VSYS) through a 10kΩ or greater pull-up resistor. See the <i>Charge Status Indication</i> section for more information.
34	ON2	Independent Enable Control Input for REG2. Drive ON2 to a logic high for normal operation, drive to GA or a logic low to disable REG2. Do not leave ON2 floating.
35	GA	Analog Ground. Connect GA directly to a quiet ground node. Connect GA, GP1, GP2, GP3, and GP4 together at a single point as close to the IC as possible.
36	REFBP	Reference Noise Bypass. Connect a 0.01μF ceramic capacitor from REFBP to GA. This pin is discharged to GA in shutdown.
37	ON4	Independent Enable Control Input for REG4. Drive ON4 to a logic high for normal operation, drive to GA or a logic low to disable REG4. Do not leave ON4 floating.
38	nRSTO	Open-Drain Reset Output. nRSTO asserts low whenever REG1 is out of regulation, and remains low for 260ms (typ) after REG1 reaches regulation.
39	nIRQ	Open-Drain Interrupt Output. nIRQ asserts any time nPBIN is asserted or an unmasked fault condition exists. When asserted by nPBIN, nIRQ automatically de-asserts when nPBIN is released. When asserted by an unmasked fault condition, nIRQ remains asserted until the ACT8828 is polled by the microprocessor. See the <i>nIRQ Output</i> section for more information.
40	CHGLEV	Charging State Select Input. When ACIN = 0 charge current is internally set; Drive CHGLEV to a logic-high for high-current USB charging mode (maximum charge current is 500mA), drive CHGLEV to a logic-low for low-current USB charging mode (maximum charge current is 100mA). When ACIN = 1 charge current is externally set by R <sub>ISSET</sub> ; Drive CHGLEV to a logic-high to for high-current charging mode (I <sub>CHG</sub> = K x 1000/R <sub>ISSET</sub> (mA) where K = 640), drive CHGLEV to a logic-low for low-current charging mode (I <sub>CHG</sub> = K x 500/R <sub>ISSET</sub> (mA) where K = 640). Do not leave CHGLEV floating.
EP	EP	Exposed Pad. Must be soldered to ground on the PCB.

## ABSOLUTE MAXIMUM RATINGS<sup>①</sup>

PARAMETER	VALUE	UNIT
CHG_IN to GA t < 1ms and duty cycle <1% Steady State	-0.3 to +18 -0.3 to +14	V V
BAT, VSYS to GA	-0.3 to +6	V
VP1 to GP1, VP2 to GP2, VP3 to GP3	-0.3 to +6	V
SW1, OUT1 to GP1	-0.3 to (V <sub>VP1</sub> +0.3)	V
SW2, OUT2 to GP2	-0.3 to (V <sub>VP2</sub> +0.3)	V
SW3, OUT3 to GP3	-0.3 to (V <sub>VP3</sub> +0.3)	V
ON1, ON2, ON3, ON4, ISET, ACIN, BTR, nPBIN, VSEL, nSTAT, DCCC, CHGLEV, TH, SCL, SDA, REFBP, nIRQ, nRSTO to GA	-0.3 to +6	V
SW4, OVP4 to GP4	-0.3 to +30	V
Operating Ambient Temperature	-40 to 85	°C
Maximum Junction Temperature	125	°C
Maximum Power Dissipation TQFN55-40 (Thermal Resistance $\theta_{JA} = 30^{\circ}\text{C/W}$ )	2.7	W
Storage Temperature	-65 to 150	°C
Lead Temperature (Soldering, 10 sec)	300	°C

①: Do not exceed these limits to prevent damage to the device. Exposure to absolute maximum rating conditions for long periods may affect device reliability.

### REGISTER DESCRIPTIONS

Table 1:  
Global Register Map

OUTPUT	ADDRESS									DATA (DEFAULT VALUE)							
	HEX	A7	A6	A5	A4	A3	A2	A1	A0	D7	D6	D5	D4	D3	D2	D1	D0
MSTR	06h	0	0	0	0	0	1	1	0	R	R	R	0	R	R	1	R
REG1	10h	0	0	0	1	0	0	0	0	R	R	V	V	V	V	V	V
REG1	11h	0	0	0	1	0	0	0	1	R	R	R	R	R	R	R	R
REG1	12h	0	0	0	1	0	0	1	0	R	R	R	R	R	0	R	1
REG1	13h	0	0	0	1	0	0	1	1	R	V	V	V	V	V	V	V
REG2	20h	0	0	1	0	0	0	0	0	R	R	V	V	V	V	V	V
REG2	21h	0	0	1	0	0	0	0	1	R	R	R	R	R	R	R	R
REG2	22h	0	0	1	0	0	0	1	0	R	R	R	R	R	0	R	1
REG2	23h	0	0	1	0	0	0	1	1	R	V	V	V	V	V	V	V
REG3	30h	0	0	1	1	0	0	0	0	R	R	V	V	V	V	V	V
REG3	31h	0	0	1	1	0	0	0	1	R	R	R	R	R	R	R	R
REG3	32h	0	0	1	1	0	0	1	0	R	R	R	R	R	0	R	1
REG3	33h	0	0	1	1	0	0	1	1	R	V	V	V	V	V	V	V
REG4	40h	0	1	0	0	0	0	0	0	R	R	R	R	R	R	R	R
REG4	41h	0	1	0	0	0	0	0	1	R	R	R	R	R	R	R	R
REG4	42h	0	1	0	0	0	0	1	0	R	R	R	R	R	0	R	1
REG4	43h	0	1	0	0	0	0	1	1	R	R	V	V	V	V	V	V

KEY:

R: Read-Only bits. No Default Assigned.

V: Default Values Depend on Voltage Option. Default Values May Vary.

Note: Addresses other than those specified in Table 1 may be used for factory settings. Do not access any registers other than those specified in Table 1.



### I<sup>2</sup>C INTERFACE ELECTRICAL CHARACTERISTICS

(V<sub>VSYS</sub> = 3.6V, T<sub>A</sub> = 25°C, unless otherwise specified.)

PARAMETER	TEST CONDITIONS	MIN	TYP	MAX	UNIT
SCL, SDA Low Input Voltage	V <sub>VSYS</sub> = 2.6V to 5.5V, T <sub>A</sub> = -40°C to 85°C			0.35	V
SCL, SDA High Input Voltage	V <sub>VSYS</sub> = 2.6V to 5.5V, T <sub>A</sub> = -40°C to 85°C	1.55			V
SCL, SDA Leakage Current				1	μA
SDA Low Output Voltage	I <sub>OL</sub> = 5mA			0.3	V
SCL Clock Period, t <sub>SCL</sub>		2.5			μs
SDA Data In Setup Time to SCL High, t <sub>SU</sub>		100			ns
SDA Data Out Hold Time after SCL Low, t <sub>HD</sub>		300			ns
SDA Data Low Setup Time to SCL Low, t <sub>ST</sub>	Start Condition	100			ns
SDA Data High Hold Time after Clock High, t <sub>SP</sub>	Stop Condition	100			ns

**Figure 1:**  
I<sup>2</sup>C Serial Bus Timing

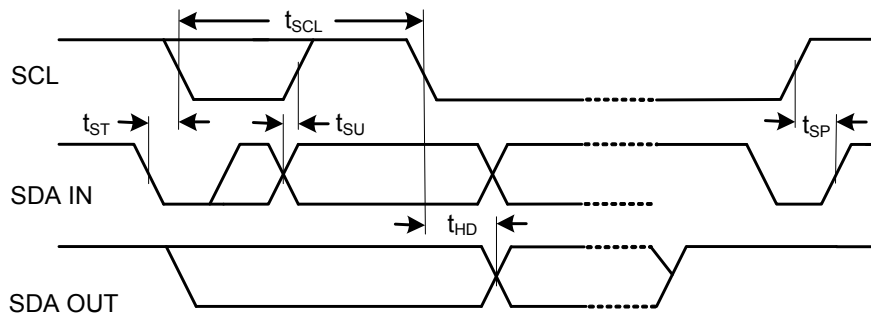

### ELECTRICAL CHARACTERISTICS

( $V_{SYS} = 3.6V$ ,  $T_A = 25^\circ C$ , unless otherwise specified.)

PARAMETER	TEST CONDITIONS	MIN	TYP	MAX	UNIT
Input Voltage Range		2.6		5.5	V
UVLO Threshold Voltage	VSYS Rising	2.35	2.5	2.7	V
UVLO Hysteresis	VSYS Falling		100		mV
VSYS Supply Current	ONx = VSYS, Not charging		100		$\mu A$
	ONx = VSYS, Charging		2		mA
VSYS Shutdown Current	ONx = GA, Not Charging		5		$\mu A$
Voltage Reference		1.24	1.25	1.26	V
Oscillator Frequency		1.35	1.6	1.85	MHz
Logic High Input Voltage	ON1, ON2, ON3, ON4, VSEL, CHGLEV	1.4			V
Logic Low Input Voltage	ON1, ON2, ON3, ON4, VSEL, CHGLEV			0.4	V
Leakage Current	ON1, ON2, ON3, ON4, VSEL, nIRQ, nRSTO			1	$\mu A$
Low Level Output Voltage	nIRQ, nRSTO. Sinking 10mA			0.3	V
nRSTO Delay			260		ms
Thermal Shutdown Temperature	Temperature rising		160		$^\circ C$
Thermal Shutdown Hysteresis	Temperature decreasing		20		$^\circ C$
nPBIN Enable/Disable Threshold	R = 100k $\Omega$			0.4	V
nPBIN Hard-Reset Threshold	R < 100k $\Omega$			0.4	V
nPBIN Internal Pull-up Resistance			50		k $\Omega$

## REGISTER DESCRIPTIONS

Note: See Table 1 for default register settings.

**Table 2:**

**Control Register Map**

ADDRESS	DATA							
	D7	D6	D5	D4	D3	D2	D1	D0
06h	R	R	R	W/E	R	R	nPBMASK	PBSTAT

R: Read-Only bits. Default Values May Vary.

W/E: Write-Exact bits. Read/Write bits which must be written exactly as specified in Table 1.

**Table 3:**

**Control Register Bit Descriptions**

ADDRESS	NAME	BIT	ACCESS	FUNCTION	DESCRIPTION	
06h	PBSTAT	[0]	R	Push Button Status	0	De-assert
					1	Asserted
06h	nPBMASK	[1]	R/W	Push Button Interrupt Mask Option	0	Masked
					1	Not Mask
06h		[3:2]	R		READ ONLY	
06h		[4]	W/E		WRITE-EXACT	
06h		[7:5]	R		READ ONLY	

### TYPICAL PERFORMANCE CHARACTERISTICS

( $V_{SYS} = 3.6V$ ,  $T_A = 25^\circ C$ , unless otherwise specified.)

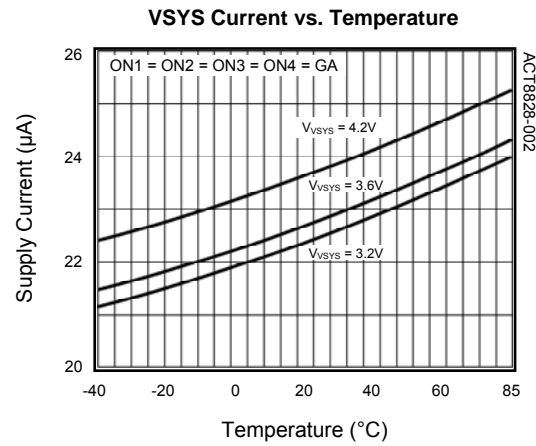
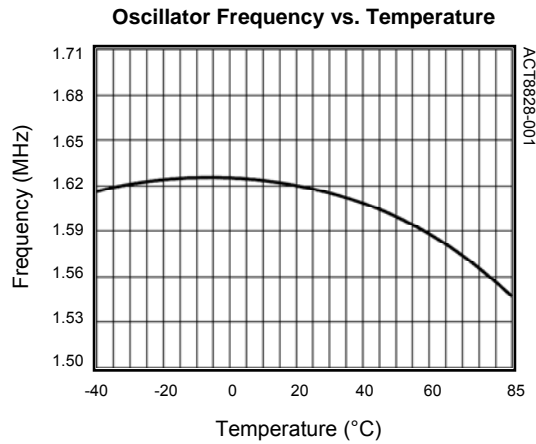

## FUNCTIONAL DESCRIPTION

### General Description

The ACT8828 offers a wide array of system management functions that allow it to be configured for optimal performance in a wide range of applications.

### I<sup>2</sup>C Serial Interface

At the core of the ACT8828's flexible architecture is an I<sup>2</sup>C interface that permits optional programming capability to enhance overall system performance.

To ensure compatibility with a wide range of system processors, the ACT8828 uses standard I<sup>2</sup>C commands; I<sup>2</sup>C write-byte commands are used to program the ACT8828, and I<sup>2</sup>C read-byte commands are used to read the ACT8828's internal registers. The ACT8828 always operates as a slave device, and is addressed using a 7-bit slave address followed by an eighth bit, which indicates whether the transaction is a read-operation or a write-operation, [1011010x].

SDA is a bi-directional data line and SCL is a clock input. The master initiates a transaction by issuing a START condition, defined by SDA transitioning from high to low while SCL is high. Data is transferred in 8-bit packets, beginning with the MSB, and is clocked-in on the rising edge of SCL. Each packet of data is followed by an "Acknowledge" (ACK) bit, used to confirm that the data was transmitted successfully.

For more information regarding the I<sup>2</sup>C 2-wire serial interface, go to the NXP website: <http://www.nxp.com>

### nPBIN Input

ACT8828's nPBIN pin is a dual-function pin, combining system enable/disable control with a hardware reset function. Referring to Figure 2, the two pin functions are obtained by asserting this pin low, either through a direct connection or through a 100kΩ resistor, as described below.

**Figure 2:**  
nPBIN Input

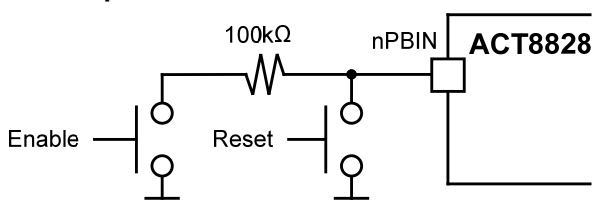

In most applications, nPBIN will be driven through a 100kΩ resistor. When driven in this way, nPBIN initiates system startup or shutdown, as described in the System Startup and Shutdown section.

When a hardware-reset function is desired, nPBIN may also be driven directly to GA. In this case, nRSTO is immediately asserted low and remains low until nPBIN is de-asserted and the reset timeout period expires. This provides a hardware-reset function, allowing the system to be manually reset if the system processor locks up.

Although a typical application will use momentary switches to drive nPBIN, as shown in Figure 2, nPBIN may also be driven by other sources, such as a GPIO or other logic output.

### Enable/Disable Inputs (ON1, ON2, ON3, and ON4)

The ACT8828 provides three manual enable/disable inputs, ON1, ON2, ON3, and ON4, which enable and disable REG1, REG2, REG3, and REG4 respectively. Once the system is enabled, the system will remain enabled until all of ON1, ON2, ON3, and ON4 have been de-asserted. See the *System Startup and Shutdown* section for more information.

### Power-On Reset Output

nRSTO is an open-drain output which asserts low upon startup or when nPBIN is driven directly to GA, and remains asserted low until the 260msec (default) power-on reset timer has expired. Connect a 10kΩ or greater pull-up resistor from nRSTO to an appropriate voltage supply.

### nIRQ Output

nIRQ is an open-drain output that asserts low any time startup or an unmasked fault condition exists. When asserted, nIRQ remains low until the microprocessor polls the ACT8828's I<sup>2</sup>C interface. The ACT8828 supports a variety of other fault conditions, which may each be optionally unmasked via the I<sup>2</sup>C interface. For more information about the available fault conditions, refer to the appropriate sections of this datasheet.

Connect a pull-up resistor from nIRQ to an appropriate voltage supply. nIRQ is typically used to drive the interrupt input of the system processor, and is useful in a variety of software-controlled enable/disable control routines.

### FUNCTIONAL DESCRIPTION CONT'D

#### Thermal Shutdown

The ACT8828 integrates thermal shutdown protection circuitry to prevent damage resulting from excessive thermal stress, as may be encountered under fault conditions. This circuitry disables all regulators if the ACT8828 die temperature exceeds 160°C, and prevents the regulators from being enabled until the IC temperature drops by 20°C (typ).

#### Control Sequence

##### Sequence A

The ACT8828QJ1## features a flexible enable architecture that allows it to support a variety of push-button enable/disable schemes. Although other startup routines are possible, a typical startup and shutdown process proceeds as shown in Figure 3.

System startup is initiated whenever the following conditions occurs:

- 1) nPBIN is pushed low via 100kΩ resistance, When condition exists, the ACT8828QJ1## begins its system startup procedure by enabling REG1. When REG1 reaches regulation, REG2 and REG3 are enable, and nRSTO is asserted low, holding the microprocessor in reset for a user selectable reset period of 260ms. If  $V_{OUT1}$  is within 6% of its regulation voltage when the reset timer expires, the nRSTO is de-asserted, and the microprocessor can begin its power-up sequence. Once the power-up routine is successfully completed, the system remains enabled after the push-button is released as long as the microprocessor asserts any one of ON1, ON2, ON3, or ON4. ON1, ON2, ON3, or ON4 enable REG1, REG2, REG3 and REG4 separately, but any one of them can enable ACT8828QJ1##.

This start-up procedure requires that the pushbutton be held until the microprocessor assumes control (by asserting any one of ON1, ON2, ON3, and ON4), providing protection against inadvertent momentary assertions of the pushbutton. If desired, longer “push-and-hold” times can be easily implemented by simply adding an additional time delay before asserting ON1, ON2, ON3, or ON4. If the microprocessor is unable to complete its power-up routine successfully before the user lets go of the push-button, the ACT8828QJ1## automatically shuts itself down.

This start-up procedure requires that the pushbutton be held until the microprocessor assumes control (by asserting any one of ON1, ON2, ON3, and ON4), providing protection against inadvertent momentary assertions of the pushbutton. If desired, longer “push-and-hold” times can be easily implemented by simply adding an additional time delay before asserting ON1, ON2, ON3, or ON4. If the microprocessor is unable to complete its power-up routine successfully before the user lets go of the push-button, the ACT8828QJ1## automatically shuts itself down.

Once a successful power-up routine is completed, a shutdown process may be initiated by asserting nPBIN a second time, typically as the result of pressing the push-button. Although the shutdown process is completely software-controlled, a typical shutdown sequence proceeds as follows: The second assertion of nPBIN asserts nPBIN and interrupts the microprocessor, which then initiates an interrupt service routine to reveal that nPBIN has been asserted. The microprocessor disables each regulator according to the sequencing requirements of the system, then the system will finally be disabled when ON1, ON2, ON3, and ON4 have been de-asserted.

**Figure 3:**  
**Sequence A**

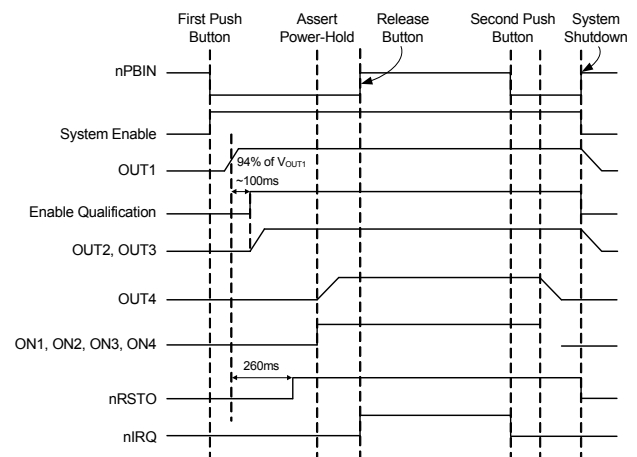

##### Sequence B

The ACT8828QJ2## features a flexible enable architecture that allows it to support a variety of push-button enable/disable schemes. Although other startup routines are possible, a typical startup

## FUNCTIONAL DESCRIPTION CONT'D

and shutdown process proceeds as shown in Figure 4.

System startup is initiated whenever the following conditions occurs:

1) nPBIN is pushed low via 100kΩ resistance, When condition exists, the ACT8828QJ2## begins its system startup procedure by enabling REG1, REG2 and REG3. When REG1 reaches regulation, nRSTO is asserted low, holding the microprocessor in reset for a user selectable reset period of 260ms. If  $V_{OUT1}$  is within 6% of its regulation voltage when the reset timer expires, the nRSTO is de-asserted, and the microprocessor can begin its power-up sequence. Once the power-up routine is successfully completed, the system remains enabled after the push-button is released as long as the microprocessor asserts any one of ON1, ON2, ON3, or ON4. ON1, ON2, ON3, or ON4 enable REG1, REG2, REG3 and REG4 separately, but any one of them can enable ACT8828QJ2##.

This start-up procedure requires that the pushbutton be held until the microprocessor assumes control (by asserting any one of ON1, ON2, ON3, and ON4), providing protection against inadvertent momentary assertions of the pushbutton. If desired, longer “push-and-hold” times can be easily implemented by simply adding an additional time delay before asserting ON1, ON2, ON3, or ON4. If the microprocessor is unable to complete its power-up routine successfully before the user lets go of the push-button, the ACT8828QJ2## automatically shuts itself down.

This start-up procedure requires that the pushbutton be held until the microprocessor assumes control (by asserting any one of ON1, ON2, ON3, and ON4), providing protection against inadvertent momentary assertions of the pushbutton. If desired, longer “push-and-hold” times can be easily implemented by simply adding an additional time delay before asserting ON1, ON2, ON3, or ON4. If the microprocessor is unable to complete its power-up routine successfully before the user lets go of the push-button, the ACT8828QJ2## automatically shuts itself down.

Once a successful power-up routine is completed, a shutdown process may be initiated by asserting nPBIN a second time, typically as the result of pressing the push-button. Although the shutdown process is completely software-controlled, a typical

shutdown sequence proceeds as follows: The second assertion of nPBIN asserts nPBIN and interrupts the microprocessor, which then initiates an interrupt service routine to reveal that nPBIN has been asserted. The microprocessor disables each regulator according to the sequencing requirements of the system, then the system will finally be disabled when ON1, ON2, ON3, and ON4 have been de-asserted.

### Sequence C

The ACT8828QJ3## features a flexible enable architecture that allows it to support a variety of push-button enable/disable schemes. Although other startup routines are possible, a typical startup and shutdown process proceeds as shown in Figure 5.

System startup is initiated whenever the following conditions occurs:

- 1) A valid input voltage is present at VIN, or
- 2) nPBIN is pushed low via 100kΩ resistance,

When any of these conditions exists, the ACT8828QJ3## begins its system startup procedure by enabling REG1. When REG1 reaches regulation, nRSTO is asserted low, holding the microprocessor in reset for a user selectable reset period of 260ms. If  $V_{OUT1}$  is within 6% of its regulation voltage when the reset timer expires, the nRSTO is de-asserted, and the microprocessor can begin its power-up sequence. Once the power-up routine is successfully completed, the system remains enabled after the push-button is released as long as the microprocessor asserts any one of ON1, ON2, ON3, or ON4. ON1, ON2, ON3, or ON4 enable REG1, REG2, REG3 and REG4 separately, but any one of them can enable ACT8828QJ3##.

This start-up procedure requires that the pushbutton be held or a valid input voltage be present at VIN until the microprocessor assumes control (by asserting any one of ON1, ON2, ON3, and ON4), providing protection against inadvertent momentary assertions of the pushbutton. If desired, longer “push-and-hold” times can be easily implemented by simply adding an additional time delay before asserting ON1, ON2, ON3, or ON4. If the microprocessor is unable to complete its power-up routine successfully before the user lets go of the push-button or un-plug the charger adapter, the ACT8828QJ3## automatically shuts itself down.



### FUNCTIONAL DESCRIPTION CONT'D

Once a successful power-up routine is completed, a shutdown process may be initiated by asserting nPBIN a second time, typically as the result of pressing the push-button. Although the shutdown process is completely software-controlled, a typical shutdown sequence proceeds as follows: The second assertion of nPBIN asserts nPBIN and interrupts the microprocessor, which then initiates an interrupt service routine to reveal that nPBIN has

been asserted. If there is no input to the charger, then the microprocessor disables each regulator according to the sequencing requirements of the system, the microprocessor disables each regulator according to the sequencing requirements of the system, then the system will finally be disabled when ON1, ON2, ON3, and ON4 have been de-asserted.

**Figure 4:**  
**Sequence B**

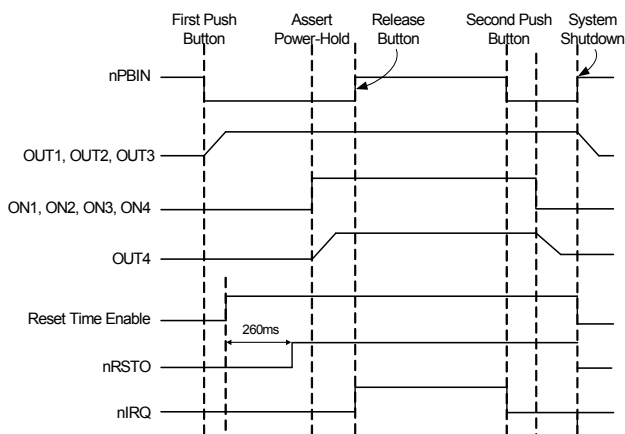

**Figure 5:**  
**Sequence C**

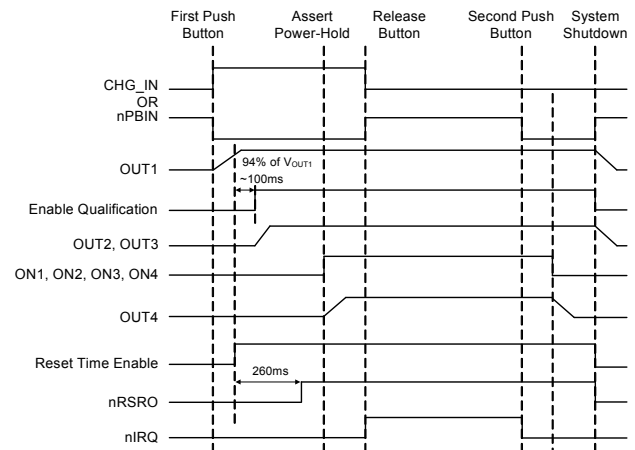



## STEP-DOWN DC/DC CONVERTERS

### ELECTRICAL CHARACTERISTICS (REG1)

( $V_{SYS} = 3.6V$ ,  $T_A = 25^\circ C$ , unless otherwise specified.)

PARAMETER	TEST CONDITIONS	MIN	TYP	MAX	UNIT
VP1 Operating Voltage Range		2.9		5.5	V
VP1 UVLO Threshold	Input Voltage Rising	2.7	2.8	2.9	V
VP1 UVLO Hysteresis	Input Voltage Falling		85		mV
Standby Supply Current			130	200	$\mu A$
Shutdown Supply Current	REG1 is disabled, $V_{VP1} = 4.2V$		0.1	1	$\mu A$
Output Voltage Regulation Accuracy	$V_{NOM1} < 1.5V$ , $I_{OUT1} = 10mA$	-2.1%	$V_{NOM1}^{\textcircled{1}}$	+2.1%	V
	$V_{NOM1} \geq 1.5V$ , $I_{OUT1} = 10mA$	-1.5%	$V_{NOM1}$	+1.5%	
Line Regulation	$V_{VP1} = \text{Max}(V_{NOM1} + 1V, 3.2V)$ to 5.5V		0.15		%/V
Load Regulation	$I_{OUT1} = 10mA$ to 1.3A		0.0017		%/mA
Current Limit		1.4	1.8		A
Oscillator Frequency	$V_{OUT1} \geq 20\%$ of $V_{NOM1}$	1.35	1.6	1.85	MHz
	$V_{OUT1} = 0V$		540		kHz
PMOS On-Resistance	$I_{SW1} = -100mA$		0.16	0.24	$\Omega$
NMOS On-Resistance	$I_{SW1} = 100mA$		0.16	0.24	$\Omega$
SW1 Leakage Current	$V_{VP1} = 5.5V$ , $V_{SW1} = 5.5V$ or 0V			1	$\mu A$
Power Good Threshold			94		% $V_{NOM1}$
Minimum On-Time			60		ns

$\textcircled{1}$ :  $V_{NOM1}$  refers to the nominal output voltage level for  $V_{OUT1}$  as defined by the *Ordering Information* section.

## STEP-DOWN DC/DC CONVERTERS

### ELECTRICAL CHARACTERISTICS (REG2)

( $V_{SYS} = 3.6V$ ,  $T_A = 25^\circ C$ , unless otherwise specified.)

PARAMETER	TEST CONDITIONS	MIN	TYP	MAX	UNIT
VP2 Operating Voltage Range		2.9		5.5	V
VP2 UVLO Threshold	Input Voltage Rising	2.7	2.8	2.9	V
VP2 UVLO Hysteresis	Input Voltage Falling		85		mV
Standby Supply Current			130	200	$\mu A$
Shutdown Supply Current	REG2 Disabled, $V_{VP2} = 4.2V$		0.1	1	$\mu A$
Output Voltage Regulation Accuracy	$V_{NOM2} < 1.5V$ , $I_{OUT2} = 10mA$	-2.1%	$V_{NOM2}^{\text{①}}$	+2.1%	V
	$V_{NOM2} \geq 1.5V$ , $I_{OUT2} = 10mA$	-1.5%	$V_{NOM2}$	+1.5%	
Line Regulation	$V_{VP2} = \text{Max}(V_{NOM2} + 1V, 3.2V)$ to 5.5V		0.15		%/V
Load Regulation	$I_{OUT2} = 10mA$ to 1.0A		0.0017		%/mA
Current Limit		1.15	1.45		A
Oscillator Frequency	$V_{OUT2} \geq 20\%$ of $V_{NOM2}$	1.35	1.6	1.85	MHz
	$V_{OUT2} = 0V$		540		kHz
PMOS On-Resistance	$I_{SW2} = -100mA$		0.25	0.38	$\Omega$
NMOS On-Resistance	$I_{SW2} = 100mA$		0.17	0.26	$\Omega$
SW2 Leakage Current	$V_{VP2} = 5.5V$ , $V_{SW2} = 5.5V$ or 0V			1	$\mu A$
Power Good Threshold			94		% $V_{NOM2}$
Minimum On-Time			60		ns

①:  $V_{NOM2}$  refers to the nominal output voltage level for  $V_{OUT2}$  as defined by the *Ordering Information* section.

## STEP-DOWN DC/DC CONVERTERS

### ELECTRICAL CHARACTERISTICS (REG3)

( $V_{SYS} = 3.6V$ ,  $T_A = 25^\circ C$ , unless otherwise specified.)

PARAMETER	TEST CONDITIONS	MIN	TYP	MAX	UNIT
VP3 Operating Voltage Range		2.9		5.5	V
VP3 UVLO Threshold	Input Voltage Rising	2.7	2.8	2.9	V
VP3 UVLO Hysteresis	Input Voltage Falling		85		mV
Standby Supply Current			130	200	$\mu A$
Shutdown Supply Current	REG3 Disabled, $V_{VP3} = 4.2V$		0.1	1	$\mu A$
Output Voltage Regulation Accuracy	$V_{NOM3} < 1.5V$ , $I_{OUT3} = 10mA$	-2.1%	$V_{NOM3}^{\text{①}}$	+2.1%	V
	$V_{NOM3} \geq 1.5V$ , $I_{OUT3} = 10mA$	-1.5%	$V_{NOM3}$	+1.5%	
Line Regulation	$V_{VP3} = \text{Max}(V_{NOM3} + 1V, 3.2V)$ to 5.5V		0.15		%/V
Load Regulation	$I_{OUT3} = 10mA$ to 550mA		0.0017		%/mA
Current Limit		0.55	0.7		A
Oscillator Frequency	$V_{OUT3} \geq 20\%$ of $V_{NOM3}$	1.35	1.6	1.85	MHz
	$V_{OUT3} = 0V$		540		kHz
PMOS On-Resistance	$I_{SW3} = -100mA$		0.46	0.69	$\Omega$
NMOS On-Resistance	$I_{SW3} = 100mA$		0.3	0.45	$\Omega$
SW3 Leakage Current	$V_{VP3} = 5.5V$ , $V_{SW3} = 5.5V$ or 0V			1	$\mu A$
Power Good Threshold			94		% $V_{NOM3}$
Minimum On-Time			60		ns

①:  $V_{NOM3}$  refers to the nominal output voltage level for  $V_{OUT3}$  as defined by the *Ordering Information* section.

## STEP-DOWN DC/DC CONVERTERS

### TYPICAL PERFORMANCE CHARACTERISTICS

(ACT8828QJ16C,  $V_{VP1} = V_{VP2} = 3.6V$ ,  $L = 3.3\mu H$ ,  $C_{VP1} = C_{VP2} = 4.7\mu F$ ,  $C_{OUT1} = 22\mu F$ ,  $C_{OUT2} = 10\mu F$ ,  $T_A = 25^\circ C$ , unless otherwise specified.)

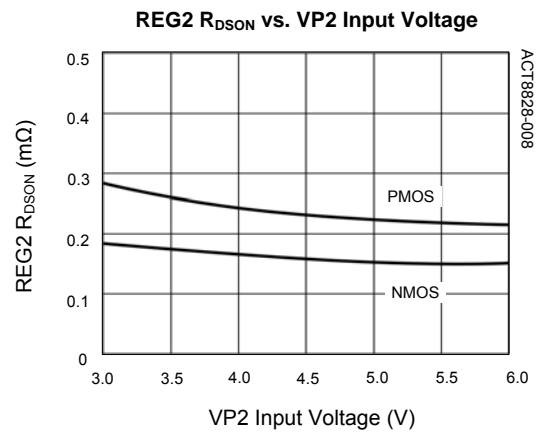
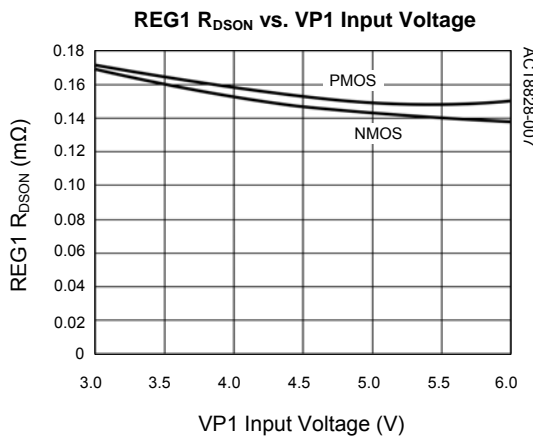
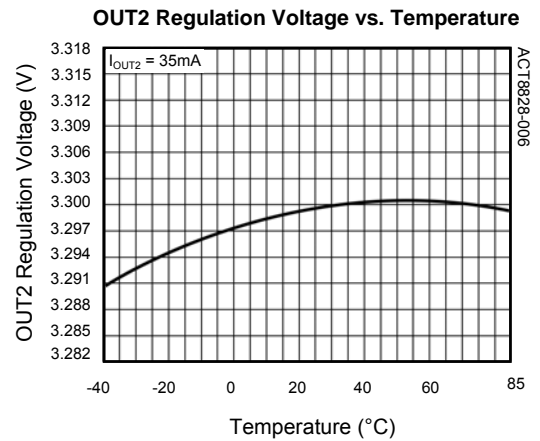
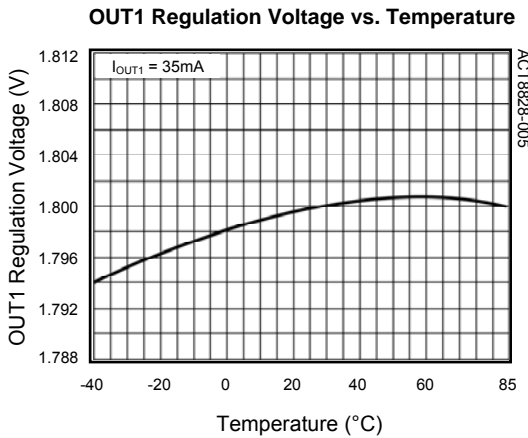
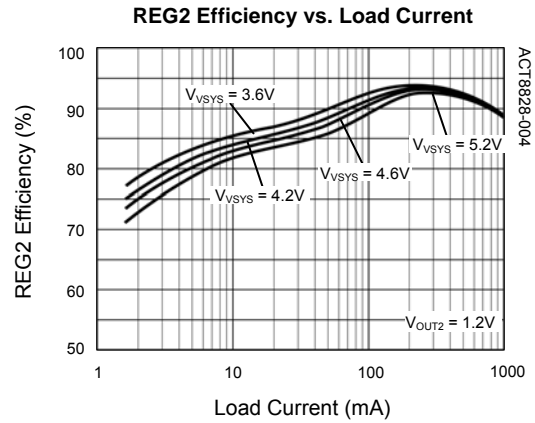
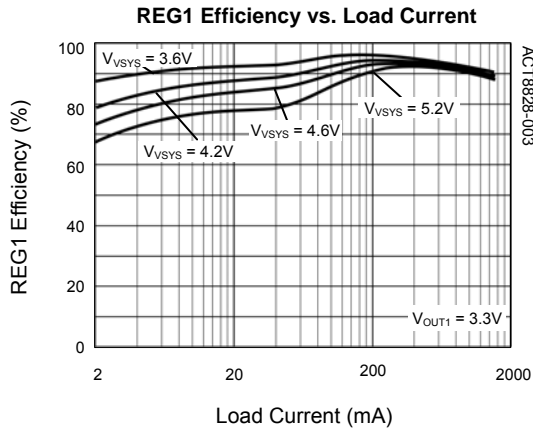

## STEP-DOWN DC/DC CONVERTERS

### TYPICAL PERFORMANCE CHARACTERISTICS CONT'D

(ACT8828QJ16C,  $V_{VP3} = 3.6V$ ,  $L = 3.3\mu H$ ,  $C_{VP3} = 4.7\mu F$ ,  $C_{OUT3} = 10\mu F$ ,  $T_A = 25^\circ C$ , unless otherwise specified.)

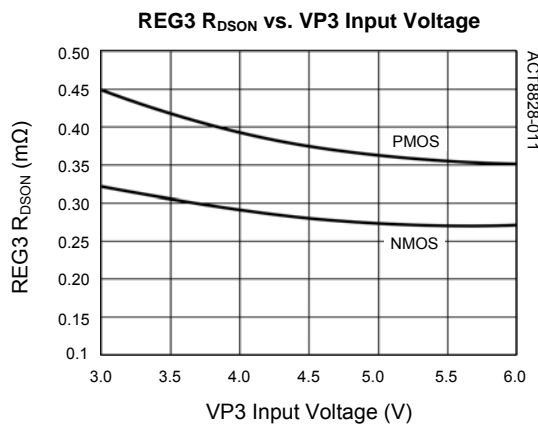
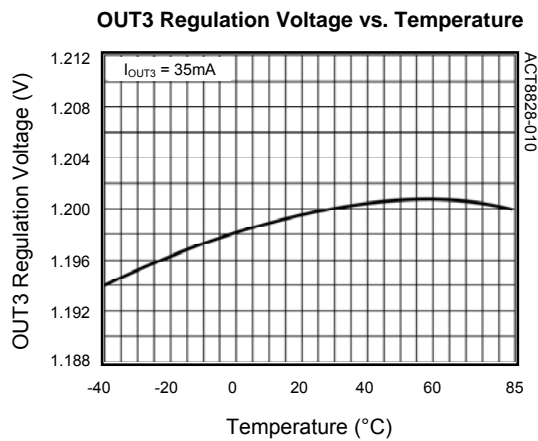
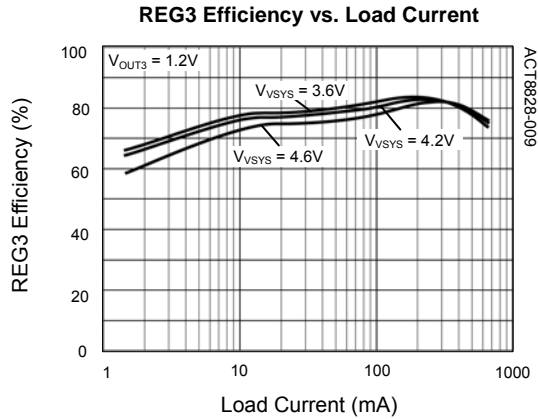

## STEP-DOWN DC/DC CONVERTERS

### REGISTER DESCRIPTIONS

Note: See Table 1 for default register settings.

**Table 4:**

**REG1 Control Register Map**

ADDRESS	DATA								
	D7	D6	D5	D4	D3	D2	D1	D0	
10h	R	R	VSET1						
11h	R	R	R	R	R	R	R	R	
12h	R	R	R	R	R	nFLTMSK	OK	ON	
13h	R	VRANGE	VSET0						

R: Read-Only bits. Default Values May Vary.

**Table 5:**

**REG1 Control Register Bit Descriptions**

ADDRESS	NAME	BIT	ACCESS	FUNCTION	DESCRIPTION	
10h	VSET1	[5:0]	R/W	REG1 Standby Output Voltage Selection	See Table 6	
10h		[7:6]	R		READ ONLY	
11h		[7:0]	R		READ ONLY	
12h	ON	[0]	R/W	REG1 Enable	0	REG1 Disable
					1	REG1 Enable
12h	OK	[1]	R	REG1 Power-OK	0	Output is not OK
					1	Output is OK
12h	nFLTMSK	[2]	R/W	REG1 Output Voltage Fault Mask Option	0	Masked
					1	Not Mask
12h		[7:3]	R		READ ONLY	
13h	VSET0	[5:0]	R/W	REG1 Output Voltage Selection	See Table 6	
13h	VRANGE	[6]	R/W	REG1 Voltage Range	0	Min $V_{OUT} = 0.8V$
					1	Min $V_{OUT} = 1.25V$
13h		[7]	R		READ ONLY	

## STEP-DOWN DC/DC CONVERTERS

### REGISTER DESCRIPTIONS CONT'D

Table 6:

REG1/VSETx[ ] Output Voltage Setting

REG1/VSETx[3:0]	REG1/VSETx[5:4]							
	REG1/VRANGE[ ] = [0]				REG1/VRANGE[ ] = [1]			
	00	01	10	11	00	01	10	11
0000	Adjustable <sup>Ⓞ</sup>	1.025	1.425	1.825	Adjustable	2.050	2.850	3.650
0001	0.800	1.050	1.450	1.850	1.300	2.100	2.900	3.700
0010	0.800	1.075	1.480	1.875	1.350	2.150	2.950	3.750
0011	0.800	1.100	1.500	1.900	1.400	2.200	3.000	3.800
0100	0.800	1.125	1.525	1.925	1.450	2.250	3.050	3.850
0101	0.800	1.150	1.550	1.950	1.500	2.300	3.100	3.900
0110	0.800	1.175	1.575	1.975	1.550	2.350	3.150	3.950
0111	0.800	1.200	1.600	2.000	1.600	2.400	3.200	4.000
1000	0.825	1.225	1.625	2.025	1.650	2.450	3.250	4.050
1001	0.850	1.250	1.650	2.050	1.700	2.500	3.300	4.100
1010	0.875	1.275	1.675	2.075	1.750	2.550	3.350	4.150
1011	0.900	1.300	1.700	2.100	1.800	2.600	3.400	4.200
1100	0.925	1.325	1.725	2.125	1.850	2.650	3.450	4.250
1101	0.950	1.350	1.750	2.150	1.900	2.700	3.500	4.300
1110	0.975	1.375	1.775	2.175	1.950	2.750	3.550	4.350
1111	1.000	1.400	1.800	2.200	2.000	2.800	3.600	4.400

Ⓞ: Refer to *Output Voltage Programming* section for more information.

## STEP-DOWN DC/DC CONVERTERS

### REGISTER DESCRIPTIONS

Note: See Table 1 for default register settings.

**Table 7:**

**REG2 Control Register Map**

ADDRESS	DATA								
	D7	D6	D5	D4	D3	D2	D1	D0	
20h	R	R	VSET1						
21h	R	R	R	R	R	R	R	R	
22h	R	R	R	R	R	nFLTMSK	OK	ON	
23h	R	VRANGE	VSET0						

R: Read-Only bits. Default Values May Vary.

**Table 8:**

**REG2 Control Register Bit Descriptions**

ADDRESS	NAME	BIT	ACCESS	FUNCTION	DESCRIPTION	
20h	VSET1	[5:0]	R/W	REG2 Standby Output Voltage Selection	See Table 9	
20h		[7:6]	R		READ ONLY	
21h		[7:0]	R		READ ONLY	
22h	ON	[0]	R/W	REG2 Enable	0	REG2 Disable
					1	REG2 Enable
22h	OK	[1]	R	REG2 Power-OK	0	Output is not OK
					1	Output is OK
22h	nFLTMSK	[2]	R/W	REG2 Output Voltage Fault Mask Option	0	Masked
					1	Not Mask
22h		[7:3]	R		READ ONLY	
23h	VSET0	[5:0]	R/W	REG2 Output Voltage Selection	See Table 9	
23h	VRANGE	[6]	R/W	REG2 Voltage Range	0	Min $V_{OUT} = 0.8V$
					1	Min $V_{OUT} = 1.25V$
23h		[7]	R		READ ONLY	



## STEP-DOWN DC/DC CONVERTERS

### REGISTER DESCRIPTIONS CONT'D

**Table 9:**  
**REG2/VSETx[ ] Output Voltage Setting**

REG2/VSETx[3:0]	REG2/VSETx[5:4]							
	REG2/VRANGE[ ] = [0]				REG2/VRANGE[ ] = [1]			
	00	01	10	11	00	01	10	11
0000	Adjustable <sup>Ⓣ</sup>	1.025	1.425	1.825	Adjustable	2.050	2.850	3.650
0001	0.800	1.050	1.450	1.850	1.300	2.100	2.900	3.700
0010	0.800	1.075	1.480	1.875	1.350	2.150	2.950	3.750
0011	0.800	1.100	1.500	1.900	1.400	2.200	3.000	3.800
0100	0.800	1.125	1.525	1.925	1.450	2.250	3.050	3.850
0101	0.800	1.150	1.550	1.950	1.500	2.300	3.100	3.900
0110	0.800	1.175	1.575	1.975	1.550	2.350	3.150	3.950
0111	0.800	1.200	1.600	2.000	1.600	2.400	3.200	4.000
1000	0.825	1.225	1.625	2.025	1.650	2.450	3.250	4.050
1001	0.850	1.250	1.650	2.050	1.700	2.500	3.300	4.100
1010	0.875	1.275	1.675	2.075	1.750	2.550	3.350	4.150
1011	0.900	1.300	1.700	2.100	1.800	2.600	3.400	4.200
1100	0.925	1.325	1.725	2.125	1.850	2.650	3.450	4.250
1101	0.950	1.350	1.750	2.150	1.900	2.700	3.500	4.300
1110	0.975	1.375	1.775	2.175	1.950	2.750	3.550	4.350
1111	1.000	1.400	1.800	2.200	2.000	2.800	3.600	4.400

Ⓣ: Refer to *Output Voltage Programming* section for more information.

## STEP-DOWN DC/DC CONVERTERS

### REGISTER DESCRIPTIONS

Note: See Table 1 for default register settings.

**Table 10:**

**REG3 Control Register Map**

ADDRESS	DATA								
	D7	D6	D5	D4	D3	D2	D1	D0	
30h	R	R	VSET1						
31h	R	R	R	R	R	R	R	R	
32h	R	R	R	R	R	nFLTMSK	OK	ON	
33h	R	VRANGE	VSET0						

R: Read-Only bits. Default Values May Vary.

WE: Write-Exact bits. Read/Write bits which must be written exactly as specified in Table 1

**Table 11:**

**REG3 Control Register Bit Descriptions**

ADDRESS	NAME	BIT	ACCESS	FUNCTION	DESCRIPTION	
30h	VSET1	[5:0]	R/W	REG3 Standby Output Voltage Selection	See Table 12	
30h		[7:6]	R		READ ONLY	
31h		[7:0]	R		READ ONLY	
32h	ON	[0]	R/W	REG3 Enable	0	REG3 Disable
					1	REG3 Enable
32h	OK	[1]	R	REG3 Power-OK	0	Output is not OK
					1	Output is OK
32h	nFLTMSK	[2]	R/W	REG3 Output Voltage Fault Mask Option	0	Masked
					1	Not Mask
32h		[7:3]	R		READ ONLY	
33h	VSET0	[5:0]	R/W	REG3 Output Voltage Selection	See Table 12	
33h	VRANGE	[6]	R/W	REG3 Voltage Range	0	Min $V_{OUT} = 0.8V$
					1	Min $V_{OUT} = 1.25V$
33h		[7]	R		READ ONLY	

## STEP-DOWN DC/DC CONVERTERS

### REGISTER DESCRIPTIONS CONT'D

Table 12:

**REG3/VSETx[ ] Output Voltage Setting**

REG3/VSETx[3:0]	REG3/VSETx[5:4]							
	REG3/VRANGE[ ] = [0]				REG3/VRANGE[ ] = [1]			
	00	01	10	11	00	01	10	11
0000	Adjustable <sup>①</sup>	1.025	1.425	1.825	Adjustable	2.050	2.850	3.650
0001	0.800	1.050	1.450	1.850	1.300	2.100	2.900	3.700
0010	0.800	1.075	1.480	1.875	1.350	2.150	2.950	3.750
0011	0.800	1.100	1.500	1.900	1.400	2.200	3.000	3.800
0100	0.800	1.125	1.525	1.925	1.450	2.250	3.050	3.850
0101	0.800	1.150	1.550	1.950	1.500	2.300	3.100	3.900
0110	0.800	1.175	1.575	1.975	1.550	2.350	3.150	3.950
0111	0.800	1.200	1.600	2.000	1.600	2.400	3.200	4.000
1000	0.825	1.225	1.625	2.025	1.650	2.450	3.250	4.050
1001	0.850	1.250	1.650	2.050	1.700	2.500	3.300	4.100
1010	0.875	1.275	1.675	2.075	1.750	2.550	3.350	4.150
1011	0.900	1.300	1.700	2.100	1.800	2.600	3.400	4.200
1100	0.925	1.325	1.725	2.125	1.850	2.650	3.450	4.250
1101	0.950	1.350	1.750	2.150	1.900	2.700	3.500	4.300
1110	0.975	1.375	1.775	2.175	1.950	2.750	3.550	4.350
1111	1.000	1.400	1.800	2.200	2.000	2.800	3.600	4.400

 ①: Refer to *Output Voltage Programming* section for more information.

**STEP-DOWN DC/DC CONVERTERS****FUNCTIONAL DESCRIPTION****General Description**

REG1, REG2, and REG3 are fixed-frequency, current-mode, synchronous PWM step-down converters that are capable of supplying up to 1.3A, 1.0A, and 0.55A of output current, respectively. These regulators operate with a fixed frequency of 1.6MHz, minimizing noise in sensitive applications and allowing the use of small external components, and achieve peak efficiencies of up to 97%.

Each step-down DC/DC is available with a variety of standard and custom output voltages, which may be software-controlled by systems requiring advanced power management functions, via the I<sup>2</sup>C interface.

**Buck Regulator PFM/PWM Operating Modes**

The buck converters offer PFM/PWM operating modes to maximize efficiency under both light and full load conditions. The device will automatically transition from fixed frequency PWM mode to PFM mode when the output current is approximately 100mA. In PFM mode, the device maintains output voltage regulation by adjusting the switching frequency. The device transitions into fixed frequency PWM mode when the output current reaches approximately 100mA.

**100% Duty Cycle Operation**

REG1, REG2 and REG3 are each capable of operating at up to 100% duty cycle. During 100% duty-cycle operation, the high-side power MOSFET is held on continuously, providing a direct connection from the input to the output (through the inductor), ensuring the lowest possible dropout voltage in battery powered applications.

**Synchronous Rectification**

REG1, REG2 and REG3 each feature integrated channel synchronous rectifiers, maximizing efficiency and minimizing the total solution size and cost by eliminating the need for external rectifiers.

**Enabling and Disabling REG1, REG2 and REG3**

REG1, REG2, and REG3 are typically enabled and disabled using the ACT8828's closed-loop enable/disable control scheme, including the nPBIN

input. Refer to the System Startup and Shutdown section for more information about this function.

Each regulator is enabled when the following conditions are met:

- 1) ONx is asserted high to enable REGx,
- 2) REGx/ONx[ ] is set to 1 when ONx is high

In addition REG1, REG2, or REG3 may be enable when nPBIN is pushed low via 100kΩ resistance. It depends on sequence is set. See the Control Sequence section for more information.

When none of these conditions are true, REG1, REG2 and REG3 are disabled, and each regulator's quiescent supply current drops to less than 1μA.

**Power-OK**

REG1, REG2 and REG3 each feature a variety of status bits that can be read by the system microprocessor. If any output falls below its power-OK threshold, typically 6% below the programmed regulation voltage, REGx/OK[ ] is cleared to 0.

**Soft-Start**

REG1, REG2 and REG3 each include matched soft-start circuitry. When enabled, the output voltages track the internal 80μs soft-start ramp and both power up in a monotonic manner that is independent of loading on either output. This circuitry ensures that each output powers up in a controlled manner, greatly simplifying power sequencing design considerations.

**Compensation**

REG1, REG2 and REG3 utilize current-mode control and a proprietary internal compensation scheme to simultaneously simplify external component selection and optimize transient performance over their full operating range. No compensation design is required; simply follow a few simple guide lines described below when choosing external components.

**Input Capacitor Selection**

The input capacitor reduces peak currents and noise induced upon the voltage source. A 4.7μF ceramic capacitor for each of REG1, REG2 and REG3 is recommended for most applications.

## STEP-DOWN DC/DC CONVERTERS

### FUNCTIONAL DESCRIPTION CONT'D

#### Output Capacitor Selection

For most applications, 22 $\mu$ F ceramic output capacitors are recommended for REG1 and 10 $\mu$ F ceramic output capacitors are recommended for REG2, REG3. Although these regulators were designed to take advantage of the benefits of ceramic capacitors, namely small size and very-low ESR, low-ESR tantalum capacitors can provide acceptable results as well.

#### Inductor Selection

REG1, REG2 and REG3 utilize current-mode control and a proprietary internal compensation scheme to simultaneously simplify external component selection and optimize transient performance over their full operating range.

The REG1, REG2 and REG3 of these devices was optimized for operation with a 3.3 $\mu$ H inductor, although inductors in the 2.2 $\mu$ H to 4.7 $\mu$ H range can be used.

Choose an inductor with a low DC-resistance, and avoid inductor saturation by choosing inductors with DC ratings that exceed the maximum output current of the application by at least 30%.

#### Output Voltage Programming

By default, REG1, REG2 and REG3 each power up and regulate to their default output voltage, as defined in the Ordering Information section. Once the system is enabled, each regulator's output voltage may be modified through either the I2C interface or the Voltage Selection (VSEL) pin.

##### Programming via the I<sup>2</sup>C Interface

Following startup, REG1, REG2, and REG3 may be independently programmed to different values by writing to the REGx/VSETx[ ] and REGx/VRANGE[ ] registers via the I2C interface. To program each regulator, first select the desired output voltage range via the REGx/VRANGE[ ] bit. Each regulator supports two overlapping ranges; set REGx/VRANGE[ ] to 0 for voltages below 2.245V, set REGx/VRANGE[ ] to 1 for voltages above 1.25V.

Once the desired range has been selected, program the output to a voltage within that range by setting the REGx/VSETx bits. For more information about the output voltage setting options, refer to Tables 4, 7, and 10, for REG1, REG2, and REG3, respectively.

#### Programming with Adjustable Option

Figure 6 shows the feedback network necessary to set the output voltage when using the adjustable output voltage option. Select components as follows: Set R<sub>FB2</sub> = 51k $\Omega$ , then calculate R<sub>FB1</sub> using the following equation:

$$R_{FB1} = R_{FB2} \left( \frac{V_{OUTx}}{V_{FBx}} - 1 \right) \quad (1)$$

Where V<sub>FBx</sub> is 0.625V when REGx  $\times$  V<sub>RANGE[ ]</sub> = 0 and 1.25V when REGx  $\times$  V<sub>RANGE[ ]</sub> = 1

**Figure 6:**  
Output Voltage Programming

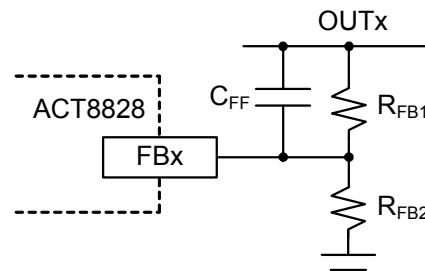

Finally choose C<sub>FF</sub> using the following equation:

$$C_{FF} = \frac{2.2 \times 10^{-6}}{R_{FB1}} \quad (2)$$

Where R<sub>FB1</sub> = 47k $\Omega$ , use 47pF. When using Adjustable Option, OUTx pins work as FBx function.

#### Output Voltage Selection Pin (VSEL)

ACT8828's VSEL pin provides a simple means of alternating between two preset output voltage settings, such as may be needed for dynamic voltage selection (DVS). The operation of this pin is as follows: when VSEL is driven to GA or a logic low, the output voltages of REG1, REG2, and REG3 are each defined by their VSET0[ ] register. When VSEL is driven to VSYS or a logic high, the output voltages of REG1, REG2, and REG3 are each defined by their VSET1[ ] register.

By default, each regulator's VSET0[ ] and VSET1[ ] registers are both programmed to the same voltage, as defined in the Ordering Information section. As a result, toggling VSET under default conditions has no effect. However, by re-programming one or more regulator's VSET0[ ] and/or VSET1[ ] registers, one can easily toggle these regulators' output voltages.

## FUNCTIONAL DESCRIPTION CONT'D

between two sets of voltages, such as to implement 'normal' and 'standby' modes in a system utilizing the ACT8828 to implement an advanced power management architecture.

### PCB Layout Considerations

High switching frequencies and large peak currents make PC board layout an important part of step-down DC/DC converter design. A good design minimizes excessive EMI on the feedback paths and voltage gradients in the ground plane, both of which can result in instability or regulation errors.

Step-down DC/DCs exhibit discontinuous input current, so the input capacitors should be placed as close as possible to the IC, and avoiding the use of vias if possible. The inductor, input filter capacitor, and output filter capacitor should be connected as close together as possible, with short, direct, and wide traces. The ground nodes for each regulator's power loop should be connected at a single point in a star-ground configuration, and this point should be connected to the backside ground plane with multiple vias. The output node for each regulator should be connected to its corresponding OUTx pin through the shortest possible route, while keeping sufficient distance from switching nodes to prevent noise injection. Finally, the exposed pad should be directly connected to the backside ground plane using multiple vias to achieve low electrical and thermal resistance.

## STEP-UP DC/DC CONVERTER

### ELECTRICAL CHARACTERISTICS (REG4)

( $V_{SYS} = 3.6V$ ,  $T_A = 25^\circ C$ , unless otherwise specified.)

PARAMETER	CONDITIONS	MIN	TYP	MAX	UNIT
Input Voltage Range		2.9		6	V
Input UVLO Threshold	Voltage Rising	2.7	2.8	2.9	V
Input UVLO Hysteresis	Voltage Falling		100		mV
Quiescent Supply Current	Not Switching		75	150	$\mu A$
Supply Current in Shutdown			0.1	1	$\mu A$
FB4 Feedback Voltage		235	255	275	mV
FB4 Input Current			50		nA
Switching Frequency		1.35	1.6	1.85	MHz
Maximum Duty Cycle		87	92		%
Switch Current Limit	Duty = 75%		800		mA
Switch On-Resistance	$I_{SW4} = 100mA$		0.45		$\Omega$
Switch Leakage Current	$V_{SW4} = 30V$ , $V_{SYS} = 3.6V$ , $ON4 = GA$			10	$\mu A$
Over Voltage Protection Threshold			28.5		V

## STEP-UP DC/DC CONVERTER

### TYPICAL PERFORMANCE CHARACTERISTICS

(ACT8828QJ16C,  $T_A = 25^\circ\text{C}$ , unless otherwise specified.)

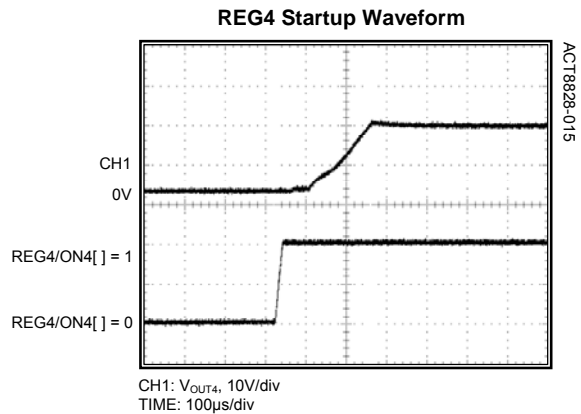
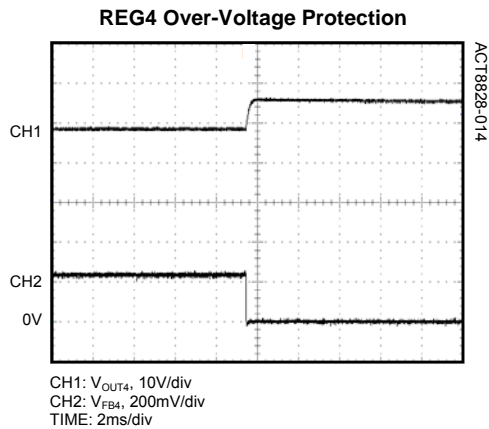
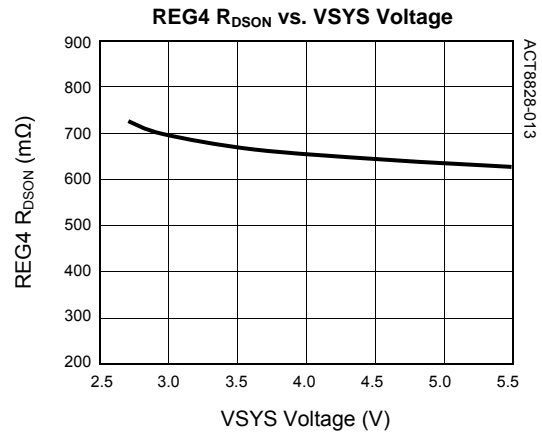
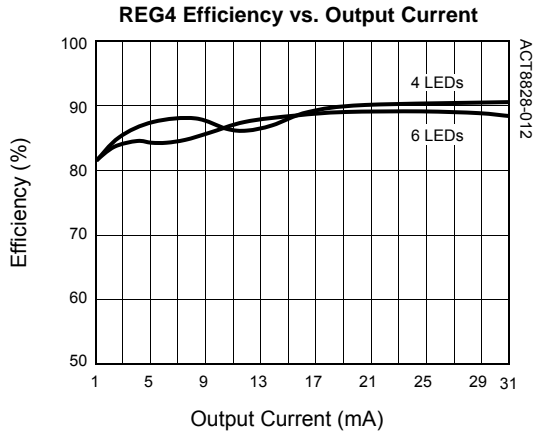



### REGISTER DESCRIPTIONS

Note: See Table 1 for default register settings.

**Table 13:**

**REG4 Control Register Map**

ADDRESS	DATA								
	D7	D6	D5	D4	D3	D2	D1	D0	
40h	R	R	R	R	R	R	R	R	
41h	R	R	R	R	R	R	R	R	
42h	R	R	R	R	R	W/E	OK	ON	
43h	R	R	VSET						

R: Read-Only bits. Default Values May Vary.

W/E: Write-Exact bits. Read/Write bits which must be written exactly as specified in Table 1.

**Table 14:**

**REG4 Control Register Bit Descriptions**

ADDRESS	NAME	BIT	ACCESS	FUNCTION	DESCRIPTION	
40h		[7:0]	R		READ ONLY	
41h		[7:0]	R		READ ONLY	
42h	ON	[0]	R/W	REG4 Enable	0	REG4 Disable
					1	REG4 Enable
42h	OK	[1]	R	REG4 Power-OK	0	Output is not OK
					1	Output is OK
42h		[2]	W/E		WRITE-EXACT	
42h		[7:3]	R		READ ONLY	
43h	VSET	[5:0]	R/W	REG4 Output Voltage Selection	See Table 15	
43h		[7:6]	R		READ ONLY	

**STEP-UP DC/DC CONVERTER**
**REGISTER DESCRIPTIONS CONT'D**

Table 15:

**REG4/VSET[ ] Over Voltage Threshold Setting**

REG4/VSET [2:0]	REG4/VSET[4:3]							
	VSET[5] = 0				VSET[5] = 1			
	00	01	10	11	00	01	10	11
000	5.00	7.00	9.00	11.00	13.00	17.00	21.00	25.00
001	5.25	7.25	9.25	11.25	13.50	17.50	21.50	25.50
010	5.50	7.50	9.50	11.50	14.00	18.00	22.00	26.00
011	5.75	7.75	9.75	11.75	14.50	18.50	22.50	26.50
100	6.00	8.00	10.00	12.00	15.00	19.00	23.00	27.00
101	6.25	8.25	10.25	12.25	15.50	19.50	23.50	27.50
110	6.50	8.50	10.50	12.50	16.00	20.00	24.00	28.00
111	6.75	8.75	10.75	12.75	16.50	20.50	24.50	28.50

**STEP-UP DC/DC CONVERTER****FUNCTIONAL DESCRIPTION****General Description**

REG4 is a highly efficient step-up DC/DC converter that employs a fixed frequency, current-mode, PWM architecture. This regulator is optimized for white-LED bias applications consisting of up to seven white-LEDs.

**Enabling and Disabling REG4**

REG1 is typically enabled and disabled using the ACT8828's closed-loop enable/disable control scheme, including the nPBIN input. Refer to the System Startup and Shutdown section for more information about this function.

Each regulator is enabled when the following conditions are met:

- 1) nPBIN is pushed low via 100kΩ resistance,
- 2) ON4 is asserted high to enable REG4,
- 3) REG4/ON4[ ] is set to 1 when ON4 is high

When none of these conditions are true, REG4 is disabled, and each regulator's quiescent supply current drops to less than 1μA.

As with all non-synchronous step-up DC/DC converters, REG4's application circuit produces a DC current path between the input and the output in shutdown mode. Although the forward drop of the WLEDs makes this leakage current very small in most applications, it is important to consider the effect that this may have in your application particularly when using fewer than three WLEDs.

**Over-Voltage Protection**

REG4 features internal over-voltage protection (OVP) circuitry which protects the system from LED open-circuit fault conditions. If the voltage at OV ever reaches the over-voltage threshold, REG4 will regulate the top of the LED string to the OVP threshold voltage. By default, the ACT8828's OVP threshold is set at 28.5V, although it may be programmed to a lower value by writing to the REG4/VSET[ ] register.

**Power-OK Bit**

REG4 features a Power-OK status bit that can be read by the system microprocessor via the I<sup>2</sup>C interface. If the voltage at OV is greater than the OVP threshold, REG4/OK[ ] will clear to 0.

**Compensation and Stability**

REG4 utilizes current-mode control and an internal compensation network to optimize transient performance, ease compensation, and improve stability over a wide range of operating conditions. REG4 is a flexible regulator, and its external components can be chosen to achieve the smallest possible footprint or to achieve the highest possible efficiency.

**Inductor Selection**

REG4 was designed to provide excellent performance across a wide range of applications, but was optimized for operation with inductors in the 10μH to 22μH range, although larger inductor values of up to 68μH can be used to achieve the highest possible efficiency.

**Optimizing for Smallest Footprint**

REG4 is capable of operating with very low inductor values in order to achieve the smallest possible footprint. When solution size is of primary concern, best results are achieved when using an inductor that ensures discontinuous conduction mode (DCM) operation over the full load current range.

**Optimizing for Highest Efficiency**

REG4 achieves excellent efficiency in applications that demand the longest possible battery life. When efficiency is the primary design consideration, best results are achieved when using an inductor that results in continuous conduction mode (CCM) operation and achieves very small inductor ripple current.

**Output Capacitor Selection**

REG4 was designed to operate with output capacitors ranging from 0.47μF to 10μF, providing design flexibility. A 1μF output capacitor is suitable for most applications, although larger output capacitors may be used to minimize output voltage ripple, if needed. Ceramic capacitors are recommended for most applications.

**Rectifier Selection**

REG4 requires a Schottky diode to rectify the inductor current. Select a low forward voltage drop Schottky diode with a forward current (I<sub>F</sub>) rating that is sufficient to support the maximum switch current and a sufficient peak repetitive reverse voltage (V<sub>RRM</sub>) to support the output voltage.

## FUNCTIONAL DESCRIPTION CONT'D

### Setting the LED Bias Current

The LED bias current is set by a resistor connected from FB4 and ground, and the regulator is satisfied when the LED current is sufficient to generate 250mV across this resistor. Once the bias current is programmed, the LED current can be adjusted using the ACT8828's Direct-PWM feature. REG4 is also compatible with a variety of well-known LED dimming circuits, such as with a DC control voltage and a filtered PWM signal.

### PCB Layout Considerations

High switching frequencies and large peak currents make PC board layout a very important part of the design. Good design minimizes excessive EMI on the feedback paths and voltage gradients in the ground plane, both of which can result in instability or regulation errors. Step-Up DC/DCs exhibit continuous input current, so there is some amount of flexibility in placing vias in the input capacitor circuit. The inductor, input filter capacitor, rectifier, and output filter capacitor should be connected as close together as possible, with short, direct, and wide traces. Connect the ground nodes together in a star configuration, with a direct connection to the exposed pad. Finally, the exposed pad should be directly connected to the backside ground plane using multiple vias to achieve low electrical and thermal resistance. Note that since the LED string is a low, DC-current path, it does not generally require special layout consideration.

### ELECTRICAL CHARACTERISTICS

( $V_{CHG\_IN} = 5V$ ,  $T_A = 25^\circ C$ , unless otherwise specified.)

PARAMETER	TEST CONDITIONS	MIN	TYP	MAX	UNIT
<b>ActivePath</b>					
CHG_IN Operating Voltage Range		4.35		12	V
CHG_IN UVLO Threshold	CHG_IN Voltage Rising	3.6	3.8	4.0	V
CHG_IN UVLO Hysteresis	CHG_IN Voltage Falling		0.8		V
CHG_IN OVP Threshold	CHG_IN Voltage Rising		6.8		V
CHG_IN OVP Hysteresis	CHG_IN Voltage Falling		350		mV
CHG_IN Supply Current	$V_{CHG\_IN} < V_{UVLO}$		20		$\mu A$
	$V_{CHG\_IN} < V_{BAT} + 120mV$ , $V_{CHG\_IN} > V_{UVLO}$	50	120	200	$\mu A$
	$V_{CHG\_IN} > V_{BAT} + 120mV$ , $V_{CHG\_IN} > V_{UVLO}$ Charger disabled, $I_{SYS} = 0mA$		1.8		mA
CHG_IN to VSYS On-Resistance	$I_{VSYS} = 100mA$		0.4	0.6	$\Omega$
CHG_IN to VSYS Current Limit	ACIN = VSYS	1.5	2	3	A
	ACIN = GA, CHGLEV = GA	85	95	105	mA
	ACIN = GA, CHGLEV = VSYS	400	450	500	
<b>VSYS AND DCCC REGULATION</b>					
VSYS Regulated Voltage	$I_{VSYS} = 10mA$	4.4	4.6	4.8	V
DCCC Pull-Up Current	$V_{CHG\_IN} > V_{BAT} + 120mV$ , Hysteresis = 50mV	92	100	108	$\mu A$
<b>nSTAT OUTPUT</b>					
nSTAT Sink current	$V_{nSTAT} = 2V$	3	5	7	mA
nSTAT Output Low Voltage	$I_{nSTAT} = 1mA$			0.4	V
nSTAT Leakage Current	$V_{nSTAT} = 4.2V$			1	$\mu A$
<b>ACIN AND CHGLEV INPUTS</b>					
CHGLEV Logic High Input Voltage		1.4			V
CHGLEV Logic Low Input Voltage				0.4	V
CHGLEV Leakage Current	$V_{CHGLEV} = 4.2V$			1	$\mu A$
ACIN Logic High Input Voltage		1.4			V
ACIN Logic Low Input Voltage				0.4	V
ACIN Leakage Current	$V_{ACIN} = 4.2V$			1	$\mu A$
<b>TEMPERATURE SENSE COMPARATOR</b>					
TH Pull-Up Current	$V_{CHG\_IN} > V_{BAT} + 120mV$ , Hysteresis = 50mV	92	100	108	$\mu A$
$V_{TH}$ Upper Temperature Voltage Threshold ( $V_{THH}$ )	Hot Detect NTC Thermistor	0.485	0.500	0.525	V
$V_{TH}$ Lower Temperature Voltage Threshold ( $V_{THL}$ )	Cold Detect NTC Thermistor	2.47	2.52	2.57	V
$V_{TH}$ Hysteresis	Upper and Lower		30		mV

### ELECTRICAL CHARACTERISTICS CONT'D

(V<sub>CHG\_IN</sub> = 5V, T<sub>A</sub> = 25°C, unless otherwise specified.)

PARAMETER	TEST CONDITIONS	MIN	TYP	MAX	UNIT	
<b>CHARGER</b>						
BAT Reverse Leakage Current	V <sub>CHG_IN</sub> = 0V, V <sub>BAT</sub> = 4.2V, I <sub>VSYS</sub> = 0mA		5		μA	
BAT to VSYS On-Resistance			80		mΩ	
ISET Pin Voltage	Fast Charge		1.02		V	
	Precondition		0.12			
Battery Regulation Voltage	T <sub>A</sub> = -20°C to 70°C	4.179	4.2	4.221	V	
	T <sub>A</sub> = -40°C to 85°C	4.170		4.230		
Charge Current	V <sub>BAT</sub> = 3.5V	ACIN = VSYS, CHGLEV = VSYS	-10%	ISET <sup>Ⓞ</sup>	+10%	mA
		ACIN = VSYS, CHGLEV = GA	-16%	50%ISET	+16%	
		ACIN = GA, CHGLEV = VSYS	-10%	Smallest (450mA or ISET)	+10%	
		ACIN = GA, CHGLEV = GA	-10%	Smallest (90mA or ISET)	+10%	
Precondition Charge Current	V <sub>BAT</sub> = 2.5V	ACIN = VSYS, CHGLEV = VSYS	12%ISET		mA	
		ACIN = VSYS, CHGLEV = GA	12%ISET			
		ACIN = GA, CHGLEV = VSYS	12%ISET			
		ACIN = GA, CHGLEV = GA	Smallest (90mA or 12%ISET)			
Precondition Threshold Voltage	V <sub>BAT</sub> Voltage Rising	2.75	2.85	2.95	V	
Precondition Threshold Hysteresis	V <sub>BAT</sub> Voltage Falling		100		mV	
End-of-Charge Current Threshold	V <sub>BAT</sub> = 4.2V	ACIN = VSYS, CHGLEV = VSYS	-10%	10%ISET	+10%	mA
		ACIN = VSYS, CHGLEV = GA	-10%	10%ISET	+10%	
		ACIN = GA, CHGLEV = VSYS	-10%	5%ISET	+10%	
		ACIN = GA, CHGLEV = GA	-10%	5%ISET	+10%	
Charge Restart Threshold	V <sub>VSYS</sub> - V <sub>BAT</sub> , V <sub>BAT</sub> Falling	150	170	190	mV	
BTR Scale Factor			0.24		s/Ω	
Precondition Safety Timer	R <sub>BTR</sub> = 47kΩ, t <sub>PRCHG</sub> = 0.24 × R <sub>BTR</sub> (Ω)/180(min)		1		hr	
Fast Charge Safety Timer	R <sub>BTR</sub> = 47kΩ, t <sub>CHG</sub> = 0.24 × R <sub>BTR</sub> (Ω)/60(min)		3		hr	
<b>THERMAL REGULATION</b>						
Thermal Regulation Threshold		100		145	°C	

Ⓞ: ISET = 640 × (1V/R<sub>ISET</sub>)

### TYPICAL PERFORMANCE CHARACTERISTICS

( $V_{CHG\_IN} = 5V$ ,  $T_A = 25^\circ C$ , unless otherwise specified.)

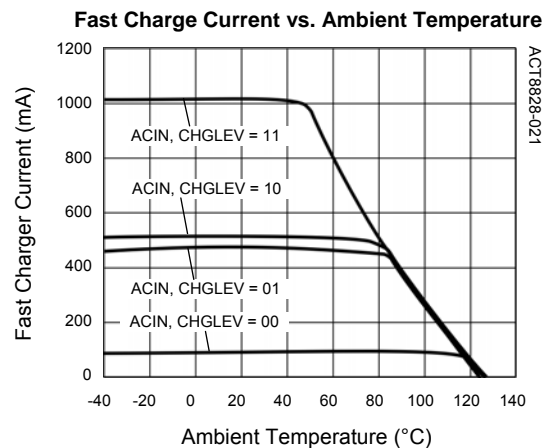
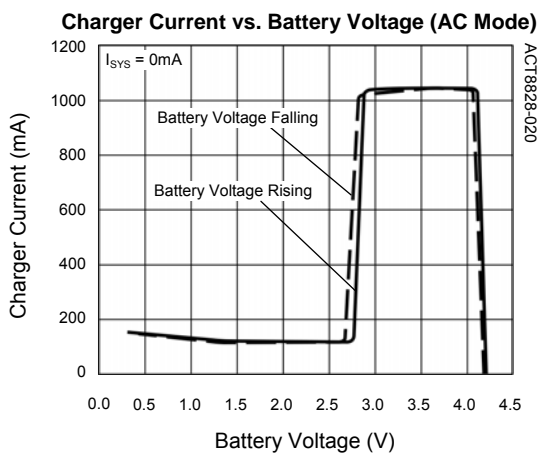
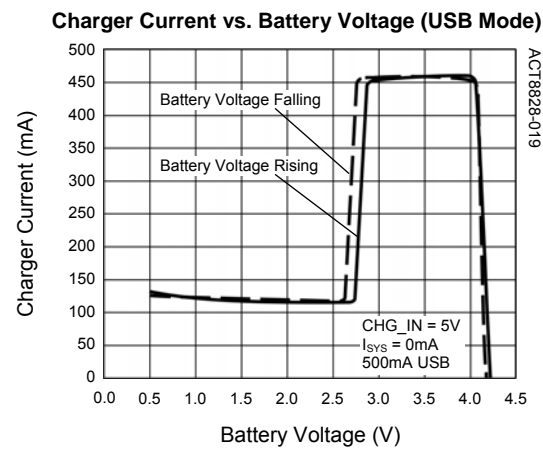
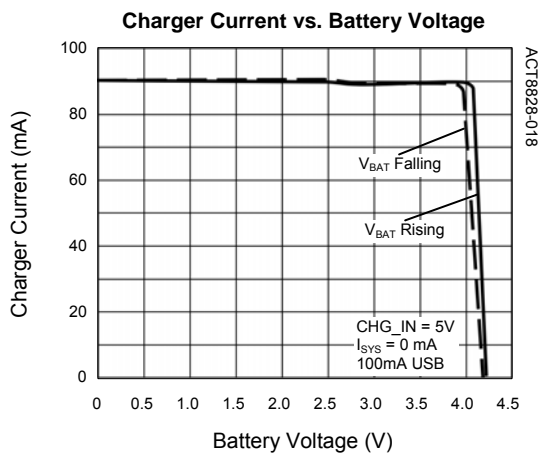
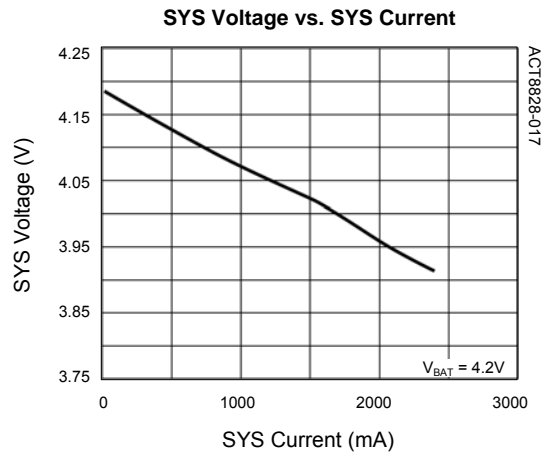
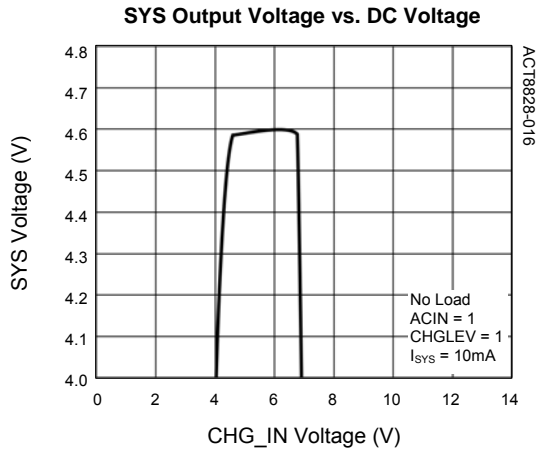

### TYPICAL PERFORMANCE CHARACTERISTICS CONT'D

( $V_{CHG\_IN} = 5V$ ,  $T_A = 25^\circ C$ , unless otherwise specified.)

VAC Applied, CHGLEV = LOW

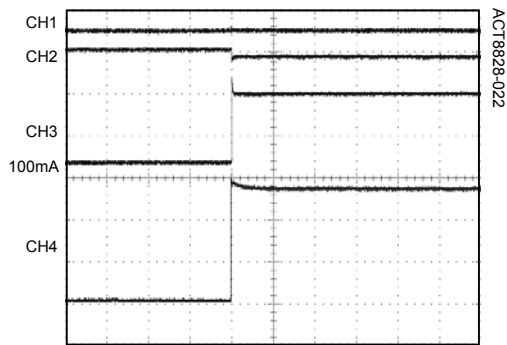

CH1:  $V_{USB}$ , 2.00V/div  
 CH2:  $V_{CHG\_IN}$ , 2.00V/div  
 CH3:  $I_{BAT}$ , 500mA/div  
 CH4:  $V_{VAC}$ , 2.00V/div  
 TIME: 400 $\mu$ s/div

VAC Applied, CHGLEV = HIGH

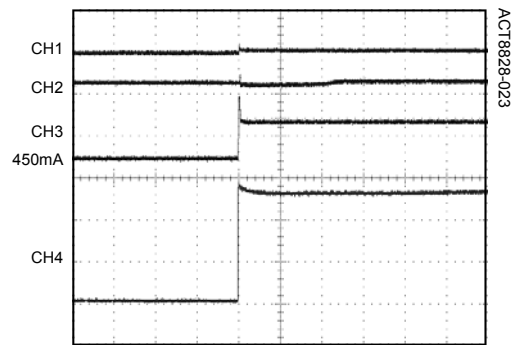

CH1:  $V_{USB}$ , 2.00V/div  
 CH2:  $V_{CHG\_IN}$ , 2.00V/div  
 CH3:  $I_{BAT}$ , 500mA/div  
 CH4:  $V_{VAC}$ , 2.00V/div  
 TIME: 400 $\mu$ s/div

VAC Removed, CHGLEV = LOW

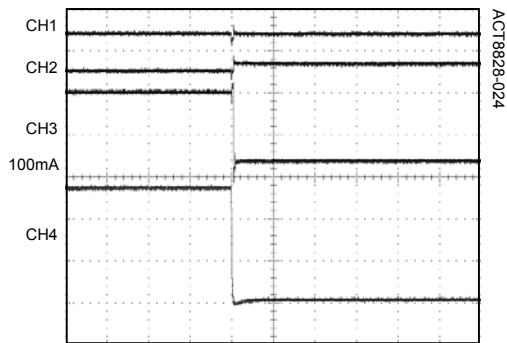

CH1:  $V_{USB}$ , 2.00V/div  
 CH2:  $V_{CHG\_IN}$ , 2.00V/div  
 CH3:  $I_{BAT}$ , 500mA/div  
 CH4:  $V_{VAC}$ , 2.00V/div  
 TIME: 400 $\mu$ s/div

VAC Removed, CHGLEV = HIGH

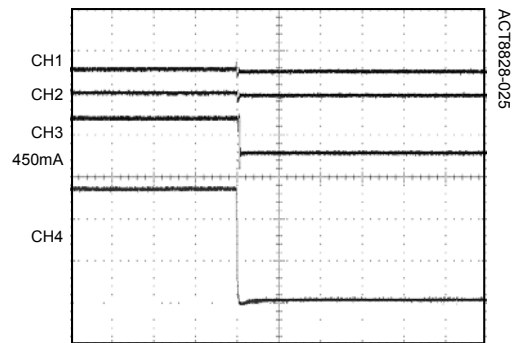

CH1:  $V_{USB}$ , 2.00V/div  
 CH2:  $V_{CHG\_IN}$ , 2.00V/div  
 CH3:  $I_{BAT}$ , 500mA/div  
 CH4:  $V_{VAC}$ , 2.00V/div  
 TIME: 400 $\mu$ s/div

Battery Leakage Current vs. Battery Voltage

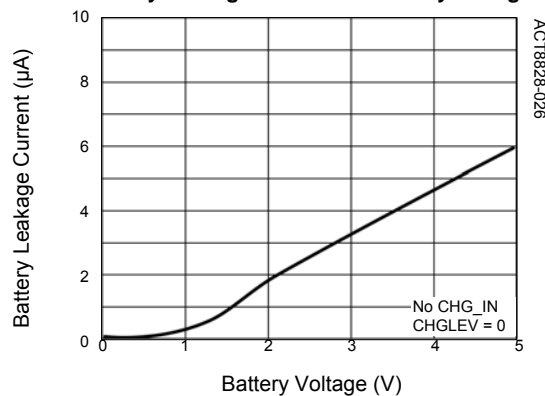



## FUNCTIONAL DESCRIPTION

### General Description

The ACT8828 incorporates Active-Semi's patent-pending *ActivePath* architecture. *ActivePath* is a complete battery-charging and system power-management solution for portable hand-held equipment. This circuitry performs a variety of advanced battery-management functions, including automatic selection of the best available input supply, current-management to ensure system power availability, and a complete, high-accuracy ( $\pm 0.5\%$ ), thermally regulated, full-featured single-cell linear Li+ charger with an integrated 12V power MOSFET.

### ActivePath Architecture

Active-semi's patent-pending *ActivePath* architecture performs three important functions:

- 1) Input Protection,
- 2) System Configuration Optimization, and
- 3) Battery-Management

#### Input Protection

At the input of the ACT8828's *ActivePath* circuit is an internal, low-dropout linear regulator (LDO) that regulates the system voltage (VSYS). This LDO features a 12V power MOSFET, allowing the *ActivePath* system to withstand input voltages of up to 12V, and additionally includes a variety of other protection features, including current limit protection and input over-voltage protection.

The *ActivePath* circuitry provides a very simple means of implementing a solution that safely operates within the current-capability limitations of a USB port while taking advantage of the high output-current capability of an AC adapter, when available.

*ActivePath* limits the total current drawn from the input supply to a value set by the ACIN input; when ACIN is driven to a logic-low *ActivePath* operates in "USB Mode" and limits the current to either 500mA (when CHGLEV is driven to a logic-high) or to 100mA (when CHGLEV is driven to a logic-low), and when ACIN is driven to a logic-high *ActivePath* operates in "AC-Mode" and limits the input current to 2A. In either case, *ActivePath*'s DCCC circuitry, described below, allows the input overload protection to be adjusted to accommodate a wide range of input supplies.

### System Configuration Optimization

*ActivePath* circuitry automatically detects the state of the input supply, the battery, and the system, and automatically reconfigures itself to optimize the power system. If the input supply is present, *ActivePath* powers the system in parallel with charging the battery, so that system power and charge current can be independently managed to satisfy all system power requirements. This allows the battery to charge as quickly as possible, while ensuring that the total system current does not exceed the capability of the input supply. If the input supply is not present, however, then *ActivePath* automatically configures the system to draw power from the battery. Finally, if the input is present and the system current requirement exceeds the capability of the input supply, such as under momentary peak-power consumption conditions, *ActivePath* automatically configures itself for maximum power capability by drawing system power from both the battery and the input supply.

### Battery Management

*ActivePath* includes a full-featured battery charger for single-cell Li-based batteries. This charger is a full-featured, intelligent, linear-mode, single-cell charger for Lithium-based cells, and was designed specifically to provide a complete charging solution with minimum system design effort.

The core of the *ActivePath*'s charger is a CC/CV (Constant-Current/Constant-Voltage), linear-mode charge controller. This controller incorporates current and voltage sense circuitry, an internal 80m $\Omega$  power MOSFET, a full-featured state-machine that implements charge control and safety features, and circuitry that eliminates the reverse-blocking diode required by conventional charger designs.

This charger also features thermal-regulation circuitry that protects it against excessive junction temperature, allowing the fastest possible charging times, as well as proprietary input protection circuitry that makes the charger robust against input voltage transients that can damage other chargers.

The charge termination voltage is highly accurate ( $\pm 0.5\%$ ), and features a selection of charge safety timeout periods that protect the system from operation with damaged cells. Other features include pin-programmable fast-charge current and

### FUNCTIONAL DESCRIPTION CONT'D

current-limited nSTAT outputs that can directly drive LED indicators or provide a logic-level status signal to the host microprocessor.

#### Dynamic Charge Current Control (DCCC)

The ACT8828's *ActivePath* charger features Dynamic Charge Current Control (DCCC) circuitry, which continuously monitors the input supply and prevents input overload conditions by dynamically adjusting the charge current to keep the input voltage from dropping below the DCCC voltage threshold.

By default, the DCCC voltage threshold is set to 4.4V, but it may also be programmed by connecting a resistor from DCCC to GA, where the resistor has value given by the following equation:

$$V_{DCCC} = 2 \times (I_{DCCC} \times R_{DCCC}) \quad (2)$$

Where  $R_{DCCC}$  is the value of the external resistor, and  $I_{DCCC}$  is the value of the current sourced from DCCC, typically 100µA.

#### Charger Current Programming

The ACT8828's *ActivePath* charger features a flexible charge current-programming scheme that combines the convenience of internal charge current programming with the flexibility of resistor based charge current programming. Current limits and charge current programming are managed as a function of the ACIN and CHGLEV pins, in combination with  $R_{ISET}$ , the resistance connected to the ISET pin.

##### ACIN and CHGLEV Inputs

ACIN is a logic input that configures the current-limit of *ActivePath*'s linear regulator as well as that of the battery charger. ACIN features a precise 1.25V logic threshold, so that the input voltage detection threshold may be adjusted with a simple resistive voltage divider. This input also allows a simple, low-cost dual-input charger switch to be implemented with just a few, low-cost components.

When ACIN is driven to a logic high, the *ActivePath* operates in "AC-Mode" and the charger charges at the current programmed by  $R_{ISET}$ ,

$$I_{CHG} = 1V/R_{ISET} \times K_{ISET} \quad (3)$$

where  $K_{ISET} = 640$  when CHGLEV is driven to a logic high, and  $K = 320$  when CHGLEV is driven to a logic low.

When ACIN is driven to a logic-low, the *ActivePath* circuitry operates in "USB-Mode", which enforces a maximum charge current setting of 500mA, if CHGLEV is driven to a logic-high, or 100mA, if CHGLEV is driven to a logic-low.

The ACT8828's charge current settings are summarized in the table below:

**Table 16:**

**ACIN and CHGLEV Inputs Table**

ACIN	CHGLEV	CHARGE CURRENT $I_{CHG}$ (mA)	PRECONDITION CHARGE CURRENT $I_{CHG}$ (mA)
0	0	90mA or 12% ISET (Smallest one)	90mA or 12% ISET (Smallest one)
0	1	450mA or ISET (Smallest one)	12% × ISET
1	0	50% × ISET	12% × ISET
1	1	ISET	12% × ISET

Note that the actual charging current may be limited to a current that is lower than the programmed fast charge current due to the ACT8828's internal thermal regulation loop. See the *Thermal Regulation and Protection* section for more information.

#### Battery Temperature Monitoring

The ACT8828 continuously monitors the temperature of the battery pack by sensing the resistance of its thermistor, and suspends charging if the temperature of the battery pack exceeds the safety limits.

In a typical application, shown in Figure 7, the TH pin is connected to the battery pack's thermistor input. The ACT8828 injects a 100µA current out of the TH pin into the thermistor, so that the thermistor resistance is monitored by comparing the voltage at TH to the internal  $V_{THH}$  and  $V_{THL}$  thresholds of 0.5V and 2.5V, respectively. When  $V_{TH} > V_{THL}$  or  $V_{TH} < V_{THH}$  charging and the charge timers are suspended. When  $V_{TH}$  returns to the normal range, charging and the charge timers resume.

The net resistance from TH to G required to cross the threshold is given by:

$$100\mu A \times R_{NOM} \times k_{HOT} = 0.5V \rightarrow R_{NOM} \times k_{HOT} = 5k\Omega$$

$$100\mu A \times R_{NOM} \times k_{COLD} = 2.5V \rightarrow R_{NOM} \times k_{COLD} = 25k\Omega$$

### FUNCTIONAL DESCRIPTION CONT'D

where  $R_{NOM}$  is the nominal thermistor resistance at room temperature, and  $k_{HOT}$  and  $k_{COLD}$  are the ratios of the thermistor's resistance at the desired hot and cold thresholds, respectively.

**Figure 7:**  
**Simple Configuration**

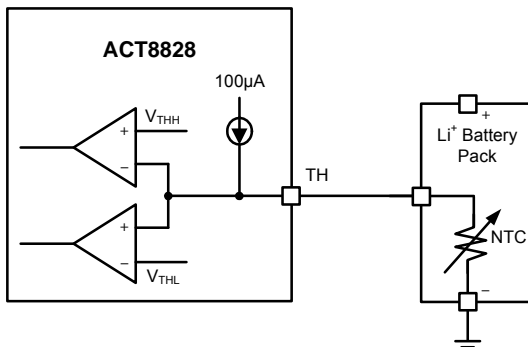

### Design Procedure

When designing with thermistors it is important to keep in mind that their nonlinear behavior typically allows one to directly control no more than one threshold at a time. As a result, the design procedure can change depending on which threshold is most critical for a given application.

Most application requirements can be solved using one of three cases,

- 1) Simple solution
- 2) Fix  $V_{THH}$ , accept the resulting  $V_{THL}$
- 3) Fix  $V_{THL}$ , accept the resulting  $V_{THH}$

The ACT8828 was designed to achieve an operating temperature range that is suitable for most applications with very little design effort. The simple solution is often found to provide reasonable results and should always be used first, then the design procedure may proceed to one of the other solutions if necessary.

In each design example, we refer to the Vishay NTHS series of NTCs, and more specifically those which follow a "curve 2" characteristic. For more information on these NTCs, as well as access to the resistance/temperature characteristic tables referred to in the example, please refer to the Vishay website at <http://www.vishay.com/thermistors>.

#### Simple Solution

The ACT8828 was designed to accommodate most

requirements with very little design effort, but also provides flexibility when additional control over a design is required. Initial thermistor selection is accomplished by choosing one that best meets the following requirements:

$$R_{NOM} = 5k\Omega/k_{HOT}, \text{ and}$$

$$R_{NOM} = 25k\Omega/k_{COLD}$$

where  $k_{HOT}$  and  $k_{COLD}$  for a given thermistor can be found on its characteristic tables.

Taking a 0°C to 40°C application using a "curve 2" NTC for this example, from the characteristic tables one finds that  $k_{HOT}$  and  $k_{COLD}$  are 0.5758 and 2.816, respectively, and the  $R_{NOM}$  that most closely satisfies these requirements is therefore around 8.8kΩ. Selecting 10kΩ as the nearest standard value, calculate  $k_{COLD}$  and  $k_{HOT}$  as:

$$k_{COLD} = V_{THL}/(I_{TH} \times R_{NOM}) = 2.5V/(100\mu A \times 10k\Omega) = 2.5$$

$$k_{HOT} = V_{THH}/(I_{TH} \times R_{NOM}) = 0.5V/(100\mu A \times 10k\Omega) = 0.5$$

Identifying these values on the curve 2 characteristic tables indicates that the resulting operating temperature range is 2°C to 44°C, vs. the design goal of 0°C to 40°C. This example demonstrates that one can satisfy common operating temperature ranges with very little design effort.

#### Fix $V_{THH}$

For demonstration purposes, supposing that we had selected the next closest standard thermistor value of 6.8kΩ in the example above, we would have obtained the following results:

$$k_{COLD} = V_{THL}/(I_{TH} \times R_{NOM}) = 2.5V/(100\mu A \times 6.8k\Omega) = 3.67$$

$$k_{HOT} = V_{THH}/(I_{TH} \times R_{NOM}) = 0.5V/(100\mu A \times 6.8k\Omega) = 0.74$$

which, according to the characteristic tables would have resulted in an operating temperature range of -6°C to 33°C vs. the design goal of 0°C to 40°C.

In this case, one can add resistance in series with the thermistor to shift the range upwards, using the following equation:

$$(V_{THH}/I_{TH}) = k_{HOT}(@40^\circ C) \times R_{NOM} + R$$

$$R = (V_{THH}/I_{TH}) - k_{HOT}(@40^\circ C) \times R_{NOM}$$

$$R = (2.5V/100\mu A) - 0.5758 \times 6.8k\Omega$$

Finally,

$$R = 5k\Omega - 3.9k\Omega = 1.1k\Omega$$

### FUNCTIONAL DESCRIPTION CONT'D

This result shows that adding 1.1kΩ in series with the thermistor sets the net resistance from TH to G to be 0.5V at 40°C, satisfying V<sub>THH</sub> at the correct temperature. Adding this resistance, however, also impacts the lower temperature limit as follows:

$$V_{THL}/I_{TH} = k_{COLD}(@TC) \times R_{NOM} + R$$

$$k_{COLD}(@TC) = (V_{THL}/I_{TH} - R)/R_{NOM}$$

Finally,

$$k_{COLD}(@TC) = (25k\Omega - 1.1k\Omega)/6.8k\Omega = 3.51$$

Reviewing the characteristic curves, the lower threshold is found to move to -5°C, a change of only 1°C. As a result, the system satisfies the upper threshold of 40°C with an operating temperature range of -5°C to 40°C, vs. our design target of 0°C to 40°C. It is informative to highlight that due to the NTC behavior of the thermistor, the relative impact on the lower threshold is significantly smaller than the impact on the upper threshold.

#### Fix V<sub>THL</sub>

Following the same example as above, the "unadjusted" results yield an operating temperature range of -6°C to 33°C vs. the design goal of 0°C to 40°C. In applications that favor V<sub>THL</sub> over V<sub>THH</sub>, however, one can control the voltage present at TH at low temperatures by connecting a resistor in

parallel with I<sub>TH</sub>. The desired resistance can be found using the following equation:

$$(I_{TH} + (V_{CHG\_IN} - V_{THL})/R) \times k_{COLD}(@0^{\circ}C) \times R_{NOM} = V_{THL}$$

Rearranging yields

$$R = (V_{CHG\_IN} - V_{THL}) / (V_{THL} / (k_{COLD}(@0^{\circ}C) \times R_{NOM}) - I_{TH})$$

$$R = (5V - 2.5V) / (2.5V / (2.816 \times 6.8k\Omega) - 100\mu A)$$

$$R = 82k\Omega$$

Adding 82kΩ in parallel with the current source increases the net current flowing into the thermistor, thus increasing the voltage at TH. Adding this resistance, however, also impacts the upper temperature limit:

$$V_{THH} = (I_{TH} + (V_{CHG\_IN} - V_{THH})/R) \times k_{HOT}(@40^{\circ}C) \times R_{NOM}$$

Rearranging yields,

$$k_{HOT}(@TC) = V_{THH} / (R_{NOM} \times (I_{TH} + (V_{CHG\_IN} - V_{THH})/R))$$

$$k_{HOT}(@TC) = 0.5V / (6.8k\Omega \times (100\mu A + (5V - 0.5V)/82k\Omega)) = 0.4748$$

Reviewing the characteristic curves, the upper threshold is found to move to 45°C, a change of about 14°C. Adding the parallel resistance has allowed us to achieve our desired lower threshold of 0°C with an operating temperature range of 0°C to 45°C, vs. our design target of 0°C to 40°C.

**Figure 8:**  
**Fix V<sub>THH</sub> Configuration**

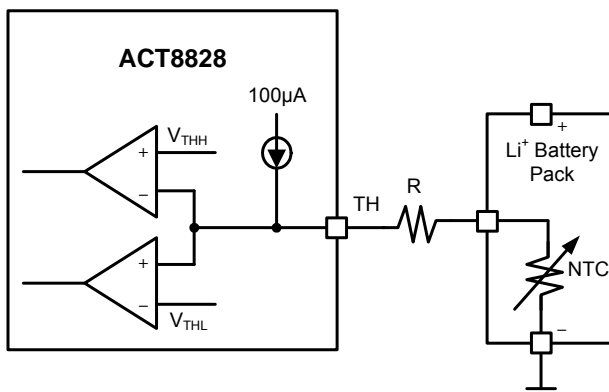

**Figure 9:**  
**Fix V<sub>THL</sub> Configuration**

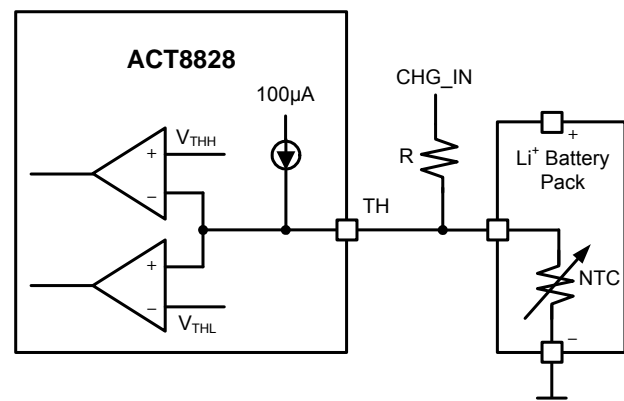



## FUNCTIONAL DESCRIPTION CONT'D

### Thermal Regulation

The ACT8828's *ActivePath* charger features an internal thermal regulation loop that reduces the charging current as necessary to ensure that the die temperature does not rise beyond the thermal regulation threshold of 110°C. This feature protects the against excessive junction temperature and makes the device more accommodating to aggressive thermal designs. Note, however, that attention to good thermal designs is required to achieve the fastest possible charge time by maximizing charge current.

In order to account for the reduced charge current resulting from operation in thermal regulation mode, the charge timeout periods are extended proportionally to the reduction in charge current.

### Charging Safety Timers

The ACT8828 features a safety timer that is programmable via an external resistor ( $R_{BTR}$ ) connected from BTR to GA. The timeout period is calculated as a function of this resistor by the following equation:

$$t_{CHG} = K_{BTR} \times R_{BTR}, \text{ where } K_{BTR} = 0.24s/\Omega.$$

If the timeout period expires prior to charge termination, the charger is disabled and the nSTAT pin signal a fault condition. If the ACT8828 detects that the charger remains in precondition for longer than the precondition time out period (which determined as  $t_{CHG}/3$ ), the ACT8828 turns off the charger and generate a FAULT to ensure prevent charging a bad cell.

### Charging Status Indication

The ACT8828 provides one charge-status output, nSTAT which indicates charge status as defined in Table 17. nSTAT is open-drain output with internal 5mA current limits, which sinks current when asserted and are high-Z otherwise, and is capable of directly driving LED without the need of current-limiting resistor or other external circuitry. To drive an LED, simply connect the LED between nSTAT pin and an appropriate supply (typically VSYS). For a logic level indication, simply connect a resistor from nSTAT to a appropriate voltage supply.

Table 17:

Charging Status Indication Table

STATE	nSTAT
Charging	ON
Discharging	OFF
Charging Complete	OFF
Input Floating	OFF
Fault	OFF

### Input Supply Detection

The ACT8828's *ActivePath* charger is capable of withstanding voltages of up to 12V, protecting the system from fault conditions such as input voltage transients or application of an incorrect input supply. Although the ACT8828 can withstand a wide range of input voltages, valid input voltages for charging must be greater than the under-voltage lockout voltage (UVLO) and the over-voltage protection (OVP) thresholds, as described below.

#### Under Voltage Lock Output (UVLO)

Whenever the input voltage applied to CHG\_IN falls below 3.8V (typ), an input under-voltage condition is detected and the charger is disabled. Once an input under-voltage condition is detected, the input must exceed the under-voltage threshold by at least 800mV for charging to resume.

#### Over Voltage Protection (OVP)

If the charger detects that the voltage applied to CHG\_IN exceeds 6.8V (typ), an over-voltage condition is detected and the charger is disabled. Once an input over-voltage condition is detected, the input must fall below the OVP threshold by at least 400mV for charging to resume.

### Reverse Leakage Current

The ACT8828's *ActivePath* charger includes internal circuitry that eliminates the need for blocking diodes, reducing solution size and cost as well as dropout voltage relative to conventional battery chargers. When the voltage at CHG\_IN falls below  $V_{BAT}$ , the charger automatically reconfigures its power switch to minimize current drain from the battery

Figure 10:  
Typical Li+ Charge Profile and ACT8828 Charge States

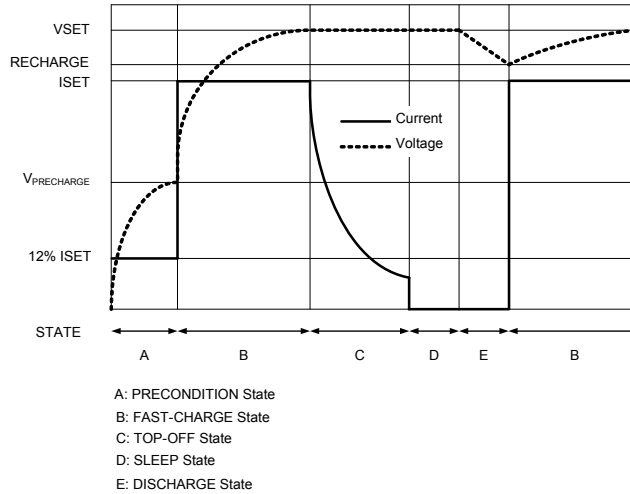
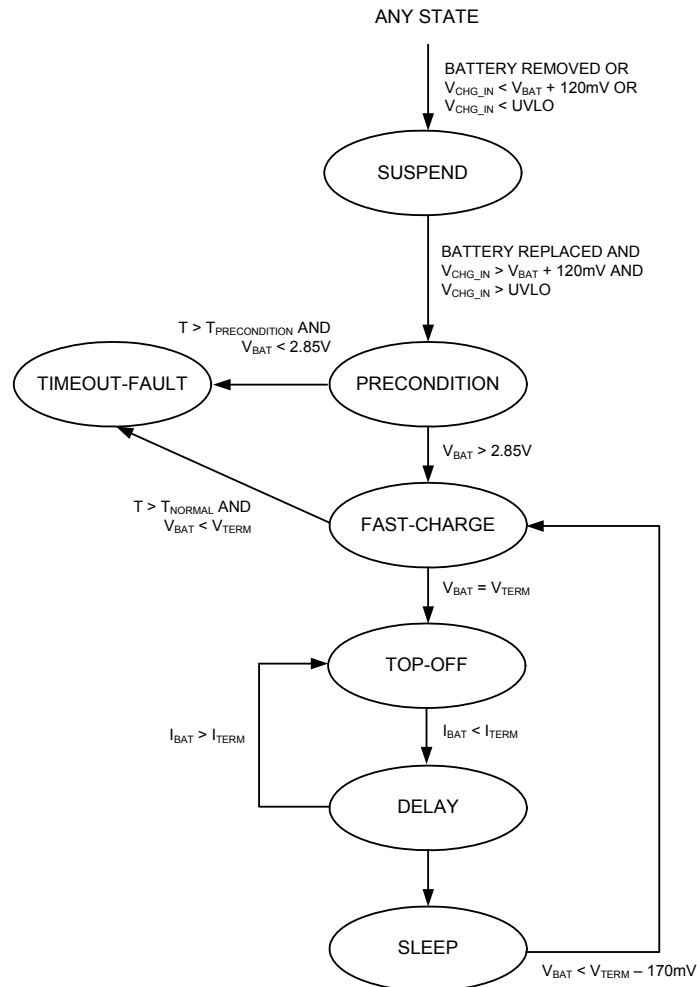

Figure 11:  
Charger State Diagram



## FUNCTIONAL DESCRIPTION CONT'D

### Charger State-Machine

#### **PRECONDITION State**

A new charging cycle begins with the PRECONDITION state, and operation continues in this state until  $V_{BAT}$  exceeds the Precondition Threshold Voltage of 2.85V (typ). When operating in PRECONDITION state, the cell is charged at a reduced current, 12% of the programmed maximum fast-charge constant current, ISET. Once  $V_{BAT}$  reaches the Precondition Threshold Voltage the state machine jumps to the NORMAL state. If  $V_{BAT}$  does not reach the Precondition Threshold Voltage before the Precondition Timeout period  $t_{PRECONDITION}$  expires, then a damaged cell is detected and the state machine jumps to the TIMEOUT-FAULT State. For the Precondition Timeout period, see the *Charging Safety Timers* section for more information.

#### **FAST CHARGE State**

Normal state is made up of two operating modes, fast charge Constant-Current (CC) and Constant-Voltage (CV). In CC mode, the ACT8828 charges at the current programmed by  $R_{ISET}$  (see the *Current Limits and Charge Current Programming* section for more information). During a normal charge cycle fast-charge continues in CC mode until  $V_{BAT}$  reaches the charge termination voltage ( $V_{TERM}$ ), at which point the ACT8828 charges in CV mode. Charging continues in CV mode until the charge current drops to 10% ( $ACIN = 1$ ) or 5% ( $ACIN = 0$ ) of the programmed maximum charge current, at which point the state machine jumps to the TOP-OFF state. If  $V_{BAT}$  does not proceed out of the NORMAL state before the Normal Timeout period ( $T_{NORMAL}$ ) expires, then a damaged cell is detected and the state machine jumps to the TIMEOUT-FAULT State. See the *Charging Safety Times* section for more information.

#### **TOP-OFF State**

In the TOP-OFF state, the cell is charged in constant-voltage (CV) mode. Charge current decreases as charging continues. During a normal charging cycle charging proceeds until the charge current decreases below the End-Of-Charge (EOC) threshold, defined as 10% of ISET ( $ACIN = 1$ ) or 5% of ISET ( $ACIN = 0$ ). When this happens, the state machine terminates the charge cycle and jumps to the SLEEP state.

#### **End of Charge State**

In the End-of-Charge (EOC) state, the ACT8828 presents a high-impedance to the battery, allowing the cell to “relax” and minimizes battery leakage current. The ACT8828 continues to monitor the cell voltage, however, so that it can re-initiate charging cycles as necessary to ensure that the cell remains fully charged.

#### **SUSPEND State**

The ACT8828 features an user-selectable suspend-charge mode, which disables the charger but keeps other circuiting functional. The charger can be put into suspend mode by driving EN to logic low. Upon exiting the SUSPEND State, the charge timer is reset and the state machine jumps to PRECONDITION state.

#### **SLEEP State**

In SLEEP mode the ACT8828 presents a high-impedance to the battery, allowing the cell to “relax” and minimizes battery leakage current. The ACT8828 continues to monitor the cell voltage, however, so that it can re-initiate charging as necessary to ensure that the cell remains fully charged. Under normal operation, the state machine initiates a new charging cycle by jumping to the FAST-CHARGE state when  $V_{BAT}$  drops below the Charge Termination Threshold.

### CHG\_IN Bypass Capacitor Selection

CHG\_IN is the power input for the ACT8828 battery charger. The battery charger is automatically enabled whenever a valid voltage is present on CHG\_IN. In most applications, CHG\_IN is connected to either a wall adapter or USB port. Under normal operation, the input of the charger will often be “hot-plugged” directly to a powered USB or wall adapter cable, and supply voltage ringing and overshoot may appear at the CHG\_IN pin.

In most applications a high quality capacitor connected from CHG\_IN to GA, placed as close as possible to the IC, is sufficient to absorb the energy. Wall-adapter powered applications provide flexibility in input capacitor selection, but the USB specification presents limitations to input capacitance selection. In order to meet both the USB 2.0 and USB OTG (On The Go) specifications while avoiding USB supply under-voltage conditions

### FUNCTIONAL DESCRIPTION CONT'D

resulting from the current limit slew rate (100mA/μS) limitations of the USB bus, the CHG\_IN bypass capacitance value must to be between 4.7μF and 10μF for the ACT8828.

Ceramic capacitors are often preferred for bypassing applications due to their small size and good surge current ratings, but care must be taken in applications that can encounter hot plug conditions as their very low ESR, in combination with the inductance of the cable, can create a high-Q filter that induces excessive ringing at the CHG\_IN pin. This ringing can couple to the output and be mistaken as loop instability, or the ringing may be large enough to damage the input itself. Although the CHG\_IN pin is designed for maximum

robustness and an absolute maximum voltage rating of 14V for transients, attention must be given to bypass techniques to ensure safe operation.

As a result, design of the CHG\_IN bypass must take care to “de-Q” the filter. This can be accomplished by connecting a 1Ω resistor in series with a ceramic capacitor (as shown in Figure 12), or by using a tantalum or electrolytic capacitor to utilize it's higher ESR to dampen the ringing. For additional protection in extreme situations, Zener diodes with 12V clamp voltages may also be used. In any case, it is always critical to evaluate voltage transients at the ACT8828 CHG\_IN pin with an oscilloscope to ensure safe operation.

**Figure 12:**  
**CHG\_IN Bypass Options for USB or Wall Adaptor Supplies**

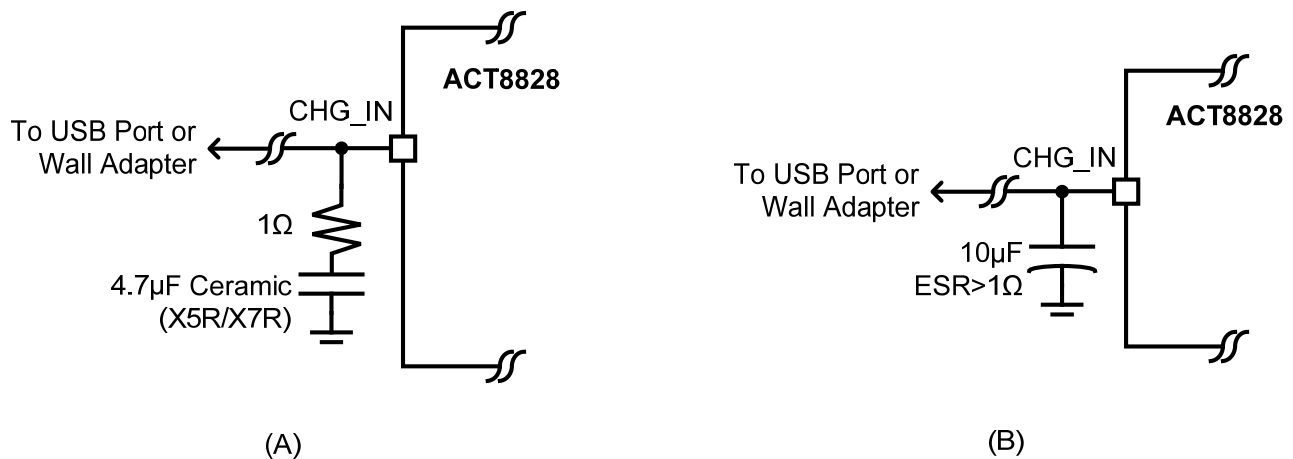



**PACKAGE OUTLINE AND DIMENSIONS**

**PACKAGE OUTLINE**

**TQFN55-40 PACKAGE OUTLINE AND DIMENSIONS**

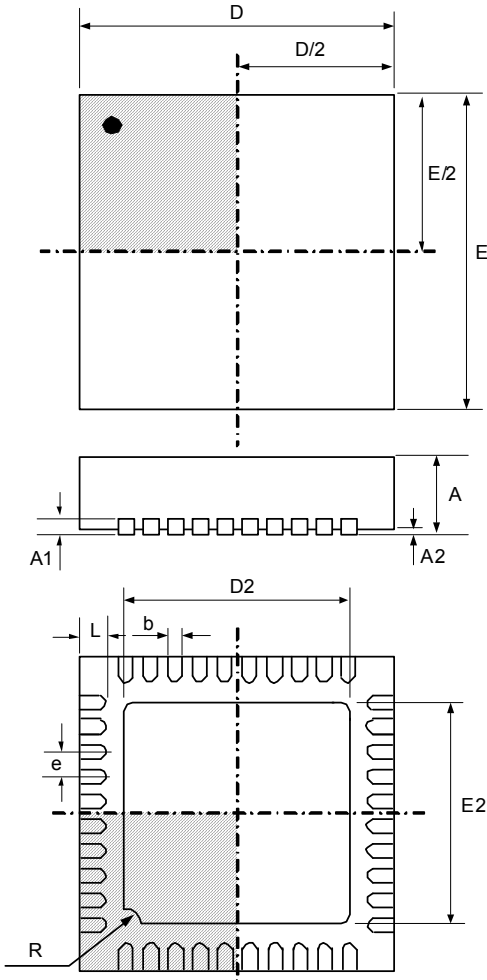

SYMBOL	DIMENSION IN MILLIMETERS		DIMENSION IN INCHES	
	MIN	MAX	MIN	MAX
A	0.700	0.800	0.028	0.031
A1	0.200 REF		0.008 REF	
A2	0.000	0.050	0.000	0.002
b	0.150	0.250	0.006	0.010
D	4.900	5.100	0.193	0.201
E	4.900	5.100	0.193	0.201
D2	3.450	3.750	0.136	0.148
E2	3.450	3.750	0.136	0.148
e	0.400 BSC		0.016 BSC	
L	0.300	0.500	0.012	0.020
R	0.300		0.012	

Active-Semi, Inc. reserves the right to modify the circuitry or specifications without notice. Users should evaluate each product to make sure that it is suitable for their applications. Active-Semi products are not intended or authorized for use as critical components in life-support devices or systems. Active-Semi, Inc. does not assume any liability arising out of the use of any product or circuit described in this datasheet, nor does it convey any patent license.

Active-Semi and its logo are trademarks of Active-Semi, Inc. For more information on this and other products, contact [sales@active-semi.com](mailto:sales@active-semi.com) or visit <http://www.active-semi.com>. For other inquiries, please send to:

2728 Orchard Parkway, San Jose, CA 95134-2012, USA