

1. Dimensions:

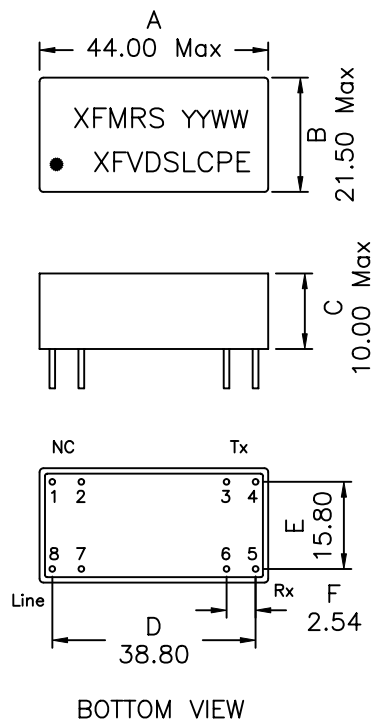

2. Schematic:

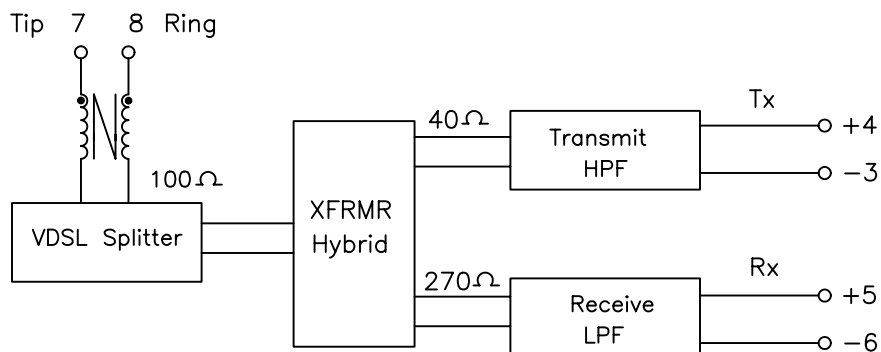

3. Electrical Specifications: @25°C

Description	Passband Frequency	Insertion Loss (Max)	Return Loss (Min)	Stopband Frequency	Attn. (Min)	Impedance
VDSL Splitter/Hybrid	900KHz-7.9MHz	0.8 dB	10 dB	20KHz-150KHz	60 dB	100 Ohms
RX LPF	900KHz-3.0MHz	1.2 dB	12 dB	4.5MHz-7.9MHz	50 dB	270 Ohms
TX HPF	4.5MHz-7.9MHz	0.8 dB	10 dB	900KHz-3.0MHz	10 dB	40 Ohms

Notes:

- Solderability: Leads shall meet MIL-STD-202, Method 208D for solderability.
- Flammability: UL94V-0
- ASTM oxygen index: > 28%
- Temperature rating: 155°C. UL file E151556
- Operating Temperature Range: All listed parameters are to be within tolerance from -0°C to +85°C

XFMR Inc

Title: **VDSL FILTER/HYBRID SOLUTION**

UNLESS OTHERWISE SPECIFIED
TOLERANCES:
.xx ±0.25
Dimensions in MM

P/N:	XFVDSLCPCE	REV. A
DWN.	廖玉坤	Jul-03-02
CHK.	李清儿	Jul-03-02
APP.	Isaiah M	Jul-03-02

DOC. REV. A/3

SHT 1 OF 1