



CHENMKO ENTERPRISE CO.,LTD

CHDTC144WUPT

**SURFACE MOUNT
NPN Digital Silicon Transistor**

VOLTAGE 50 Volts CURRENT 30 mAmpere

Lead free devices

APPLICATION

* Switching circuit, Inverter, Interface circuit, Driver circuit.

FEATURE

- * Small surface mounting type. (SC-70/SOT323)
- * High current gain.
- * Suitable for high packing density.
- * Low collector-emitter saturation.
- * High saturation current capability.
- * Internal isolated NPN transistors in one package.
- * Built in bias resistor(R1=47kΩ, Typ.)

CONSTRUCTION

* One NPN transistors and bias of thin-film resistors in one package.

MARKING

WUB

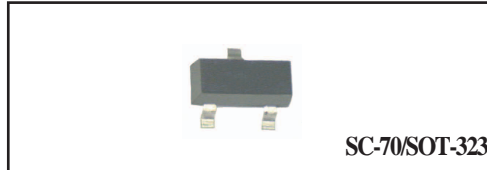

SC-70/SOT-323

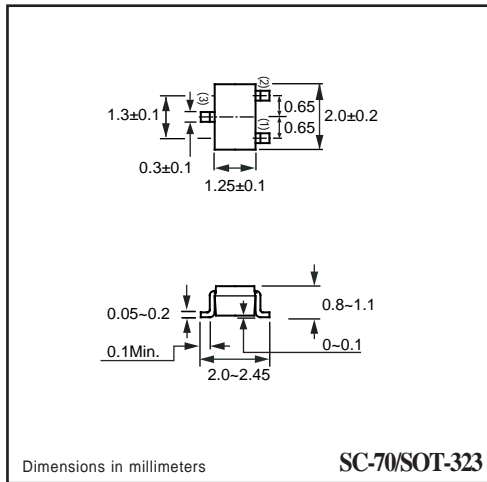

Dimensions in millimeters

SC-70/SOT-323

CIRCUIT

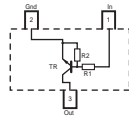

LIMITING VALUES

In accordance with the Absolute Maximum Rating System (IEC 60134).

SYMBOL	PARAMETER	CONDITIONS	MIN.	MAX.	UNIT
V _{CC}	Supply voltage		–	50	V
V _{IN}	Input voltage		-10	+40	V
I _O	DC Output current		–	30	mA
I _{C(Max.)}			–	100	
P _{TOT}	Total power dissipation	T _{amb} ≤ 25 °C, Note 1	–	200	mW
T _{STG}	Storage temperature		-55	+150	°C
T _J	Junction temperature		–	150	°C
R _{θJ-S}	Thermal resistance	junction - soldering point	–	140	°C/W

Note

1. Transistor mounted on an FR4 printed-circuit board.

RATING CHARACTERISTIC (CHDTC144WUPT)

CHARACTERISTICS

$T_{amb} = 25\text{ }^{\circ}\text{C}$ unless otherwise specified.

SYMBOL	PARAMETER	CONDITIONS	MIN.	TYP.	MAX.	UNIT
$V_{I(off)}$	Input off voltage	$I_o=100\mu\text{A}; V_{CC}=5.0\text{V}$	0.8	–	–	V
$V_{I(on)}$	Input on voltage	$I_o=2\text{mA}; V_o=0.3\text{V}$	–	–	3.0	V
$V_{O(on)}$	Output voltage	$I_o=10\text{mA}; I_i=0.5\text{mA}$	–	0.1	0.3	V
I_i	Input current	$V_i=5\text{V}$	–	–	0.16	mA
$I_{C(off)}$	Output current	$V_i=0\text{V}; V_{CC}=50\text{V}$	–	–	0.5	μA
h_{FE}	DC current gain	$I_o=5\text{mA}; V_o=5.0\text{V}$	56	–	–	
R_1	Input resistor		32.9	47	61.1	$\text{K}\Omega$
R_2/R_1	Resistor ratio		0.37	0.47	0.57	
f_T	Transition frequency	$I_E=-5\text{mA}, V_{CE}=10.0\text{V}$ $f=100\text{MHz}$	–	250	–	MHz

Note

1. Pulse test: $t_p \leq 300\mu\text{s}; \delta \leq 0.02$.