

## Miniature Resistance Weld Crystal

The HC49U series is an industry AT-cut crystal housed in a MIL standard HC49U package.

# HC49U

- AT-cut performance
- Low cost for volume applications
- Tight specifications available
- Wide frequency range available
- Complies with Directive 2002/95/EC (RoHS Compliant)

### Specifications:

**Frequency Range:** 1.8432 MHz ~ 40 MHz Fundamental  
23 MHz ~ 200 MHz Overtone

**Operating Temperature:**

0°C ~ +50°C	-A
-10°C ~ +60°C	-B
-20°C ~ +70°C	-C
-40°C ~ +85°C	-L

**Storage Temperature:** -40°C ~ +85°C

**Frequency Tolerance:** (at 25°C)

± 50 ppm	-50
± 30 ppm	-30
± 20 ppm	-20
± 10 ppm	-10

**Frequency Stability:** (over temperature range)

± 50 ppm	-50
± 30 ppm	-30
± 20 ppm	-20
± 10 ppm	-10

**Circuit Condition:** 10 pF ~ 32 pF or series

**Equivalent Series Resistance:** Maximum resistance corresponds to frequency. Please see ESR table.

**Drive Level:** 1.0 mW max

**Shunt Capacitance:** 7 pF max

**Aging:** ± 5 ppm max per year

**Optional Features:**

Fundamental	-F
3 <sup>rd</sup> , 5 <sup>th</sup> , 7 <sup>th</sup> O.T.	-3,5,7
Tape & Reel	-T

Note:

1. Other frequencies, tolerances, stabilities, and operating temperature ranges available. Consult VTC Support for specific requirements.
2. Not all combinations of the above tolerances, stabilities, and temperature ranges are available. Consult VTC Support if your requirement is not standard.
3. All specifications subject to change without notice.

### HC-49/U

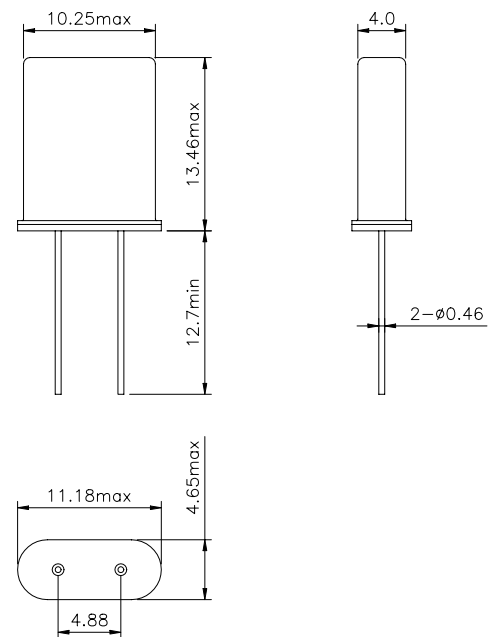

All dimensions are in mm

### Ordering Information

Product name + CL + Operating Temperature Range + Tolerance + Stability + Other Code + Frequency.

i.e. HC49U-20-C-30-30-F-24.000MHz