

Analog 5-wire PET-On-Glass Touch Screen Specification

1. Mechanical Dimensions and Construction

- 1.1 General: Analog Resistive touch screen is laminated by ITO PET to ITO glass.
- 1.2 Construction:

Item	Description	Material	Remarks
1	ITO PET (Top layer) New designed printing	0.188mm ITO PET Film	Antiglare coating Surface hardness: 3H Resistance:300~600Ω/□
2	ITO Patterned Glass (Bottom layer) New designed printing	1.1 mm ITO Glass	Resistance:300~900Ω/□
3	Tail Base	Kapton	Separated Tail
4	Tail cover lay	Kapton	
5	Connector	AMP compatible	2,54mm
6	Top layer circuit	Silver ink	
7	Bottom layer circuit	Silver ink	
8	Layer to layer contacted	Silver ink	
9	Dot spacer	UV Cure ink	
10	Isolation Layer	Isolation Adhesive	
11	Glue	UV Glue	

Touch screen side view:

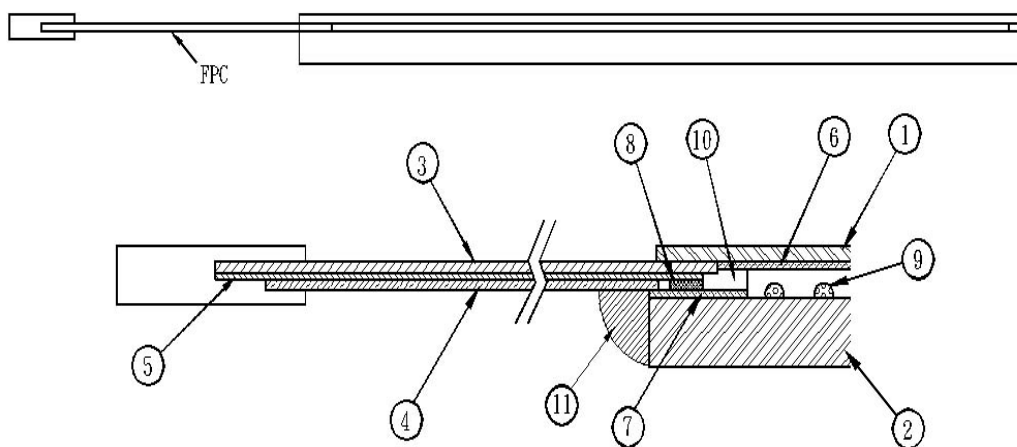

Changes that contribute to technical improvement are subject to alternations

				2006	Datum	Name	TOUCH SCREEN 6,48", 5-Wire AMT-02516-01 SPECIFICATIONS OF ANALOG RESISTIVE PET-ON-GLASS TOUCH SCREEN Manufactured by Apex Material Technology Corp.
				Bearb.	18.08.	Maurer	
				Gepr.	18.08	Maurer	
				Vert.			
				EDV-Datasheet don't change manually			
				 ELECTRONIC COMPONENTS			
				D 79346 Endingen			
Zu	Änd.	Datum	Name				H 1070.0469 page 1 of 4 Index: -

1.3 Input Method and Activation Force

Input Method	Average Activation Force
16mm dia. Silicon "finger"	Less than 1.00 N

2. Typical Optical Characteristics

- 2.1 Visible Light Transmission: > 80%
- 2.2 Haze: < 13%

3. Electrical Specifications

- 3.1 Operating Voltage: 5.5V or less
- 3.2 Contact current: 20mA (maximum)
- 3.3 Circuit close resistance: 20~300Ω
- 3.4 Circuit open resistance: > 10MΩ at 25VDC
- 3.5 Contact bounce: < 15ms
- 3.6 Linearity Specifications: The linearity specifications are based on Hampshire or PenMount touch screen controllers and drivers to define.
- 3.6.1 Inner Active Area : 10 mm inside of X and Y active area dimensions.
- Perimeter of Active Area : The area 10 mm inside of X and Y active area dimensions.

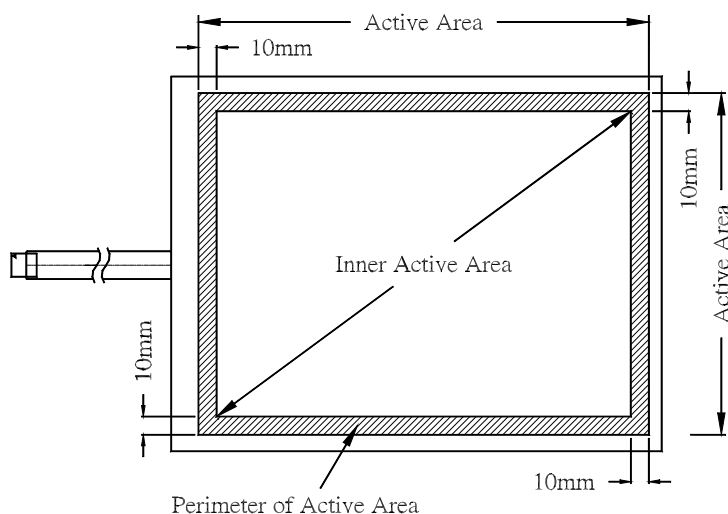

Changes that contribute to technical improvement are subject to alternations

				2006	Datum	Name	TOUCH SCREEN 6,48", 5-Wire AMT-02516-01 SPECIFICATIONS OF ANALOG RESISTIVE PET-ON-GLASS TOUCH SCREEN Manufactured by Apex Material Technology Corp.
				Bearb.	18.08.	Maurer	
				Gepr.	18.08	Maurer	
				Vert.			
				EDV-Datasheet don't change manually			
				D 79346 Endingen			
Zu	Änd.	Datum	Name				H 1070.0469 page 2 of 4 Index: -

3.6.2 Calculate Linearity

$$\%Linearity = \frac{\sqrt{\Delta X^2 + \Delta Y^2}}{Active\ Area\ Diagonal} * 100$$

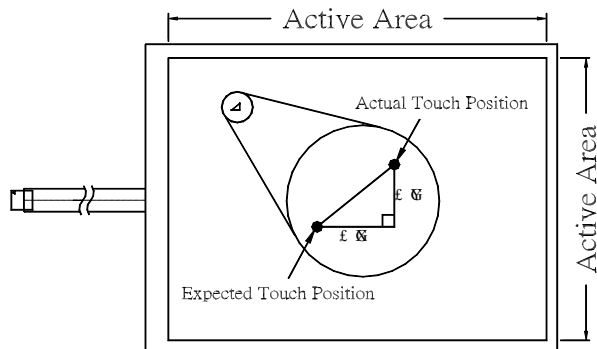

3.6.3 Linearity:

Inner Active Area : <1.0%
Perimeter of Active Area : <1,5%

3.7 Electrostatic Discharge Protection : (per EN 61000-4-2) The touch screen withstands of 15KV air discharge and 8KV contact discharge.

4. Environment Specification

- 4.1 Operating Temperature - 10° C ~ + 60° C Humidity less than 90% RH, no dew condensation
- 4.2 Storage Temperature - 40° C ~ + 80° C, at Ambient Humidity

5. Reliability Test

- 5.1 Exposure to high temperature
Touch panel is put into a test machine at the condition of 80°C for 504 hours. Then it is left at the room temperature for 24 hours or more. The measurement must satisfy the following:
 - Circuit close resistance: as Sec. 3.3
 - Circuit open resistance: as Sec. 3.4
 - Contact bounce: as Sec. 3.5
 - Linearity test: as Sec. 3.6

- 5.2 Exposure to low temperature
Touch panel is put into a test machine at the condition of -40°C for 504 hours. Then it is left at the room temperature for 24 hours or more. The measurement must satisfy the following:
 - Circuit close resistance: as Sec. 3.3
 - Circuit open resistance: as Sec. 3.4
 - Contact bounce: as Sec. 3.5
 - Linearity test: as Sec. 3.6

Changes that contribute to technical improvement are subject to alternations

				2006	Datum	Name	TOUCH SCREEN 6,48", 5-Wire AMT-02516-01 SPECIFICATIONS OF ANALOG RESISTIVE PET-ON-GLASS TOUCH SCREEN Manufactured by Apex Material Technology Corp.
				Bearb.	18.08.	Maurer	
				Gepr.	18.08	Maurer	
				Vert.			
				EDV-Datasheet don't change manually			
				 ELECTRONIC COMPONENTS			
				D 79346 Endingen			
Zu	Änd.	Datum	Name				H 1070.0469 page 3 of 4 Index: -

5.3 Exposure to constant temperature and humidity

Touch panel is put into a test machine at the condition of 60°C, 90%RH for 504 hours. Then it is left at the room temperature for 24 hours or more. The measurement must satisfy the following:

- Circuit close resistance: as Sec. 3.3
- Circuit open resistance: as Sec. 3.4
- Contact bounce: as Sec. 3.5
- Linearity test: as Sec. 3.6

5.4 Thermal Shock

Touch panel is put into a test machine at the condition of -40°C for 30 minutes, and then 80°C for 30 minutes. The process is repeated by 10 cycles. Then it is left at the room temperature for 24 hours or more. The measurement must satisfy the following:

- Circuit close resistance: as Sec. 3.3
- Circuit open resistance: as Sec. 3.4
- Contact bounce: as Sec. 3.5
- Linearity test: as Sec. 3.6

6. Durability test:

6.1 Finger touches

Touch panel is hit 36 millions times with a silicone rubber of R8 finger, hitting rate is by 250g at 2 times per second. The measurement must satisfy the following:

- Circuit close resistance: as Sec. 3.3
- Circuit open resistance: as Sec. 3.4
- Contact bounce: as Sec. 3.5
- Linearity test: as Sec. 3.6

7. Optical Performance:

7.1 Optical inspection method and optical defect standards refer to document. A001-2 Touch Screen Optical Quality Standard.

7.2 Outside to Active Area : any optical defected in this area need to be ignored if no effected to touch screen function.

8. Others

8.1 Always store the touch screen in its original shipping container under normal conditions (20~25°C, 65% RH)

Changes that contribute to technical improvement are subject to alternations

				2006	Datum	Name	TOUCH SCREEN 6,48", 5-Wire AMT-02516-01 SPECIFICATIONS OF ANALOG RESISTIVE PET-ON-GLASS TOUCH SCREEN Manufactured by Apex Material Technology Corp.
				Bearb.	18.08.	Maurer	
				Gepr.	18.08	Maurer	
				Vert.			
				EDV-Datasheet don't change manually			
							H 1070.0469
				D 79346 Endingen			
Zu	Änd.	Datum	Name				page 4 of 4 Index: -