

**PLEASE CHECK WWW.MOLEX.COM FOR LATEST PART INFORMATION**

**Part Number:** [0678008245](#)  
**Status:** **Active**  
**Overview:** [serial\\_ata\\_products](#)  
**Description:** 1.27mm (.050") Pitch Serial ATA High Speed Header, Vertical, Through Hole, with Locking Latch, 7 Circuits, 0.38µm (15µ") Gold (Au) Plating, for 1.60mm (.063") PCB, High Temperature, Natural, Footprint A, with PCBLocator Tabs, Lead-free

**Documents:**

[3D Model](#) [RoHS Certificate of Compliance \(PDF\)](#)  
[Drawing \(PDF\)](#)

**Agency Certification**

CSA LR 19980

**General**

Product Family PCB Headers  
 Series [67800](#)  
 Application Board-to-Board, Wire-to-Board  
 Comments In-line Solder Pin|Footprint A  
 Overview [serial\\_ata\\_products](#)  
 Product Name Serial ATA

**Physical**

Breakaway No  
 Circuits (Loaded) 7  
 Circuits (maximum) 7  
 Durability (mating cycles max) 500  
 Flammability 94V-0  
 Glow-Wire Compliant No  
 Lock to Mating Part Yes  
 Material - Plating Mating Gold  
 Material - Plating Termination Tin  
 Number of Rows 1  
 Orientation Vertical  
 PC Tail Length (in) 0.083 In  
 PC Tail Length (mm) 2.10 mm  
 PCB Locator Yes  
 PCB Retention Yes  
 PCB Thickness Recommended (in) 0.062 In  
 PCB Thickness Recommended (mm) 1.60 mm  
 Packaging Type Tray  
 Pitch - Mating Interface (in) 0.050 In  
 Pitch - Mating Interface (mm) 1.27 mm  
 Shrouded Fully  
 Stackable No  
 Surface Mount Compatible (SMC) Yes  
 Temperature Range - Operating -55°C to +85°C  
 Termination Interface: Style Through Hole

**Electrical**

Current - Maximum per Contact 1.5A  
 Voltage - Maximum 15V

**Material Info**

**Reference - Drawing Numbers**

Packaging Specification PK-67800-001

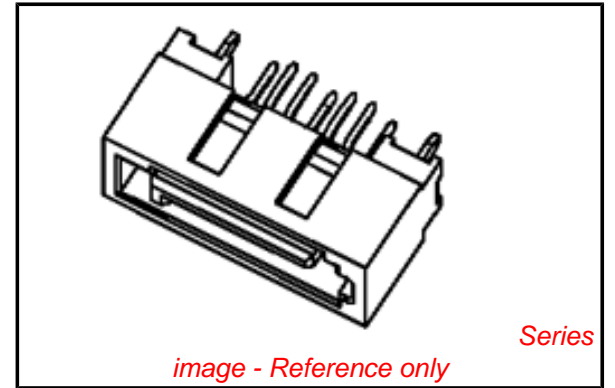

**EU RoHS**

**ELV and RoHS Compliant**  
**REACH SVHC**  
 Not Reviewed  
**Halogen-Free Status**  
**Not Reviewed**

**China RoHS**



**Need more information on product environmental compliance?**

Email [productcompliance@molex.com](mailto:productcompliance@molex.com)  
 For a multiple part number RoHS Certificate of Compliance, [click here](#)

Please visit the [Contact Us](#) section for any non-product compliance questions.

**Search Parts in this Series**

67800Series

This document was generated on 05/25/2010

**PLEASE CHECK [WWW.MOLEX.COM](http://WWW.MOLEX.COM) FOR LATEST PART INFORMATION**

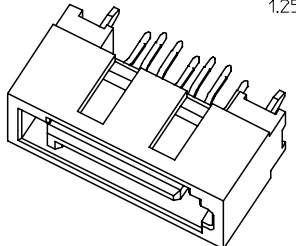
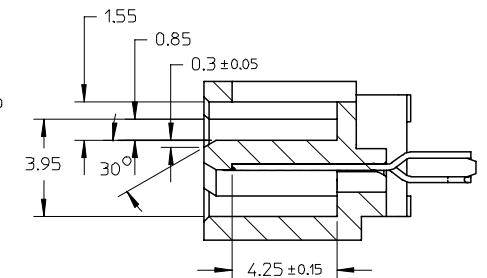
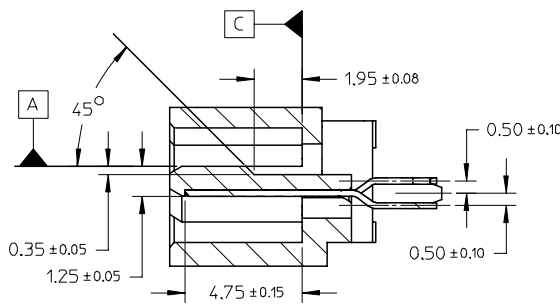
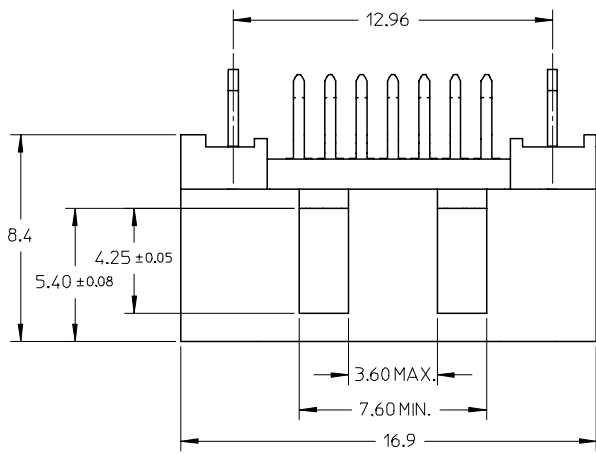

SECTION A-A

SECTION C-C

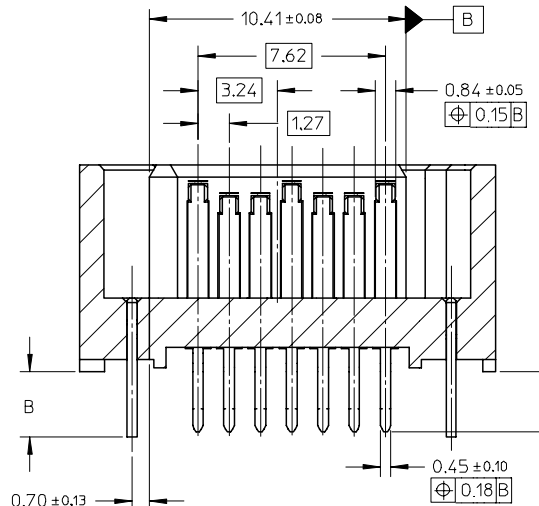
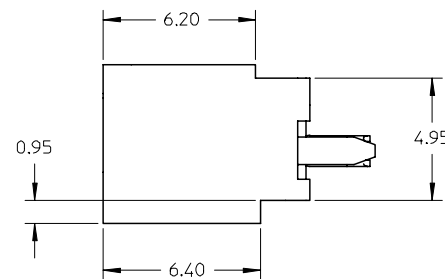

SECTION B-B

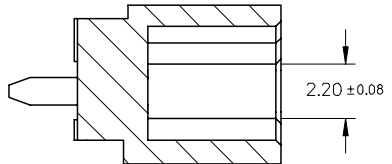
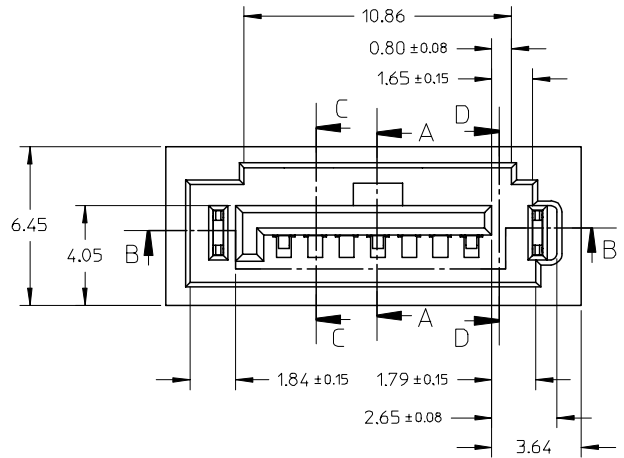

SECTION D-D

ADD PART NUMBER EC NO: SH2007-0324 DRWN: BCHENZ6 CHKD: JTIAN APPR: JNCHEN	2006/11/06 2006/11/06 2006/11/15
---	--

QUALITY SYMBOLS	▽=0 ◁=0
-----------------	------------

GENERAL TOLERANCES (UNLESS SPECIFIED)	mm	INCH
4 PLACES	± ---	± ---
3 PLACES	± ---	± ---
2 PLACES	± 0.15	± ---
1 PLACE	± 0.25	± ---
ANGULAR ± 1 °		
DRAFT WHERE APPLICABLE MUST REMAIN WITHIN DIMENSIONS		

DIMENSION STYLE MM ONLY	
DRAWN BY GRATE	DATE 2004/02/02
CHECKED BY YA JUN	DATE 2004/02/02
APPROVED BY SAM	DATE 2004/02/02
MATERIAL NO.	
SEE SHEET 2	

SCALE 5:1	DESIGN UNITS METRIC	THIRD ANGLE PROJECTION
TITLE HIGH SPEED CONNECTOR 1.27MM PITCH VERTICAL DIP SOLDER TAIL		
MOLEX INCORPORATED		
DOCUMENT NO. SD-67800-008	SHEET NO. 1 OF 2	
THIS DRAWING CONTAINS INFORMATION THAT IS PROPRIETARY TO MOLEX INCORPORATED AND SHOULD NOT BE USED WITHOUT WRITTEN PERMISSION		

10 9 8 7 6 5 4 3 2 1

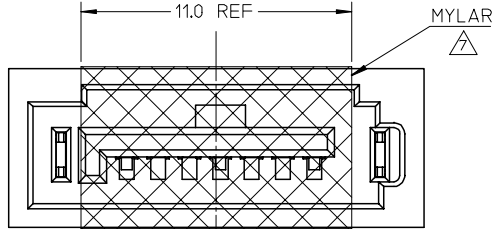
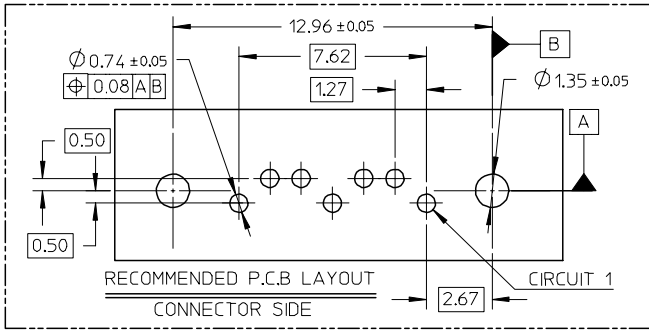

SCHEMATIC DRAWING OF MYLAR ONLY FOR 678008205 (SCALE 5:1)

- NOTES:
- MATERIAL:  
HOUSING/COLOR: SEE CHART, GLASS FILLED, UL94V-0,  
TERMINAL/PEG: BRASS
  - TERMINAL PLATING:  
CONTACT AREA: (a) GOLD FLASH  
(b) GOLD, THICKNESS=0.76 MICRON MINIMUM  
(c) GOLD, THICKNESS=0.38 MICRON MINIMUM  
SOLDER TAIL: TIN PLATED 1.27 MICRON MINIMUM OVER  
NICKEL PLATED 1.27 MICRON MINIMUM
  - POST PLATING: TIN PLATED 1.27 MICRON MINIMUM OVER  
NICKEL PLATED 1.8 MICRON MINIMUM
  - PACKAGING:  
FOR 678008205: TAPE & REEL, REFER TO PK-67800-003  
FOR OTHER P/N: TRAY, REFER TO PK-67800-001
  - PRODUCT SPECIFICATION REFER TO PS-67491-001
  - RECOMMENDED SOLDERING PROCESS:  
THERMAL PLASTIC FOR WAVE SOLDEING PROCESS  
HIGH TEMPERATURE THERMAL PLASTIC FOR IR SOLDERING PROCESS
7. THE MYLAR STICKED ON THE HOUSING IS JUST USED FOR PICK-UP PLACE, PLEASE REMOVE IT AFTER REFLOW

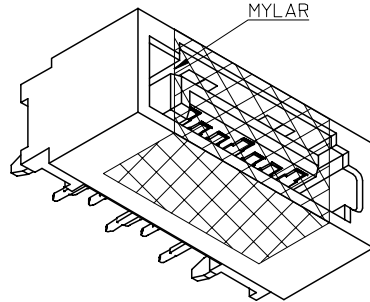

ADD PART NUMBER	DESCRIPTION	DIM A	DIM B	P.C.B THICKNESS	PLASTIC TYPE	PLASTIC COLOR	REMARK
678008065	SEE NOTE2(c)						
678008062	SEE NOTE2(b)	3.25	3.45	2.40+/-0.05			
678008061	SEE NOTE2(a)						
678008055	SEE NOTE2(c)						
678008052	SEE NOTE2(b)	2.85	3.05	2.00+/-0.05	THERMAL PLASTIC	NATURE COLOR	
678008051	SEE NOTE2(a)						
678008245	SEE NOTE2(c)	2.10					
678008045	SEE NOTE2(c)						
678008042	SEE NOTE2(b)	2.45	2.65	1.60+/-0.05			
678008041	SEE NOTE2(a)						
678008085	SEE NOTE2(c)						
678008082	SEE NOTE2(b)	3.25	3.45	2.40+/-0.05			
678008081	SEE NOTE2(a)						
678008075	SEE NOTE2(c)						
678008072	SEE NOTE2(b)	2.85	3.05	2.00+/-0.05	THERMAL PLASTIC	PROCESS BLUE C ΔE<3	
678008071	SEE NOTE2(a)						
678008235	SEE NOTE2(c)	2.10					PURE TIN
678008035	SEE NOTE2(c)						
678008032	SEE NOTE2(b)	2.45	2.65	1.60+/-0.05			
678008031	SEE NOTE2(a)						
678008025	SEE NOTE2(c)						
678008022	SEE NOTE2(b)	3.25	3.45	2.40+/-0.05			
678008021	SEE NOTE2(a)						
678008015	SEE NOTE2(c)						
678008012	SEE NOTE2(b)	2.85	3.05	2.00+/-0.05	THERMAL PLASTIC	BLACK	
678008011	SEE NOTE2(a)						
678008305	SEE NOTE2(c)	2.10					
678008005	SEE NOTE2(c)						
678008002	SEE NOTE2(b)	2.45	2.65	1.60+/-0.05			
678008001	SEE NOTE2(a)						
MATERIAL NUMBER	PLATING TYPE	DIM A	DIM B	P.C.B THICKNESS	PLASTIC TYPE	PLASTIC COLOR	REMARK

MATERIAL NUMBER	PLATING TYPE	DIM A	DIM B	P.C.B THICKNESS	PLASTIC TYPE	PLASTIC COLOR	REMARK
678008125	SEE NOTE2(c)						
678008122	SEE NOTE2(b)	3.25	3.45	2.40+/-0.05			
678008121	SEE NOTE2(a)						
678008115	SEE NOTE2(c)						HIGH TEMPERATURE
678008112	SEE NOTE2(b)	2.85	3.05	2.00+/-0.05	THERMAL PLASTIC	BLACK	PURE TIN
678008111	SEE NOTE2(a)						
678008205	SEE NOTE2(c)						
678008105	SEE NOTE2(c)	2.45	2.65	1.60+/-0.05			
678008102	SEE NOTE2(b)						
678008101	SEE NOTE2(a)						

ADD PART NUMBER EC NO: SH2007-0324 DRWN: BCHENZ6 CHKD: JTIAN APPR: JNCHEN	QUALITY SYMBOLS ▽=0 ▽C=0	GENERAL TOLERANCES (UNLESS SPECIFIED)		DIMENSION STYLE MM ONLY		SCALE 1:1		DESIGN UNITS METRIC		THIRD ANGLE PROJECTION	
		4 PLACES ± --- ± --- 3 PLACES ± --- ± --- 2 PLACES ± 0.15 ± --- 1 PLACE ± 0.25 ± ---		DRAWN BY GRATE DATE 2004/02/02		TITLE HIGH SPEED CONNECTOR 1.27MM PITCH VERTICAL DIP SOLDER TAIL		APPROVED BY SAM DATE 2004/02/02		MOLEX INCORPORATED	
		ANGULAR ± 1 °		MATERIAL NO. SEE CHART		DOCUMENT NO. SD-67800-008		SHEET NO. 2 OF 2			
		DRAFT WHERE APPLICABLE MUST REMAIN WITHIN DIMENSIONS		SIZE A3		THIS DRAWING CONTAINS INFORMATION THAT IS PROPRIETARY TO MOLEX INCORPORATED AND SHOULD NOT BE USED WITHOUT WRITTEN PERMISSION					

9 8 7 6 5 4 3 2 1