

PLEASE CHECK WWW.MOLEX.COM FOR LATEST PART INFORMATION

Part Number: [0039000048](#)
Status: **Active**
Overview: [minifit_jr](#)
Description: 4.20mm (.165") Pitch Mini-Fit™ Crimp Terminal, Male, with Tin (Sn) Plated Brass Contact, 22-28 AWG, Reel

Documents:

Test Summary (PDF)	Product Specification PS-52034-004 (PDF)
Drawing (PDF)	Product Specification PS-5556-001 (PDF)
Product Specification PS-51010-005 (PDF)	Product Specification PS-5556-002 (PDF)
Product Specification PS-51010-006 (PDF)	Product Specification PS-5556-003 (PDF)
Product Specification PS-51096-001 (PDF)	RoHS Certificate of Compliance (PDF)
Product Specification PS-52034-003 (PDF)	

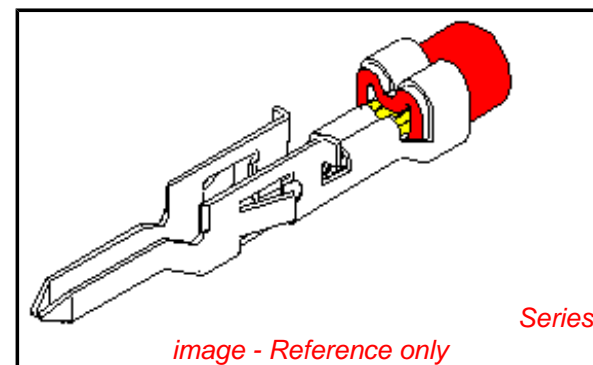

General

Product Family	Crimp Terminals
Series	5558
Crimp Quality Equipment	Yes
Overview	minifit_jr
Product Name	Mini-Fit®

Physical

Durability (mating cycles max)	30
Gender	Male
Material - Metal	Brass
Material - Plating Mating	Tin
Material - Plating Termination	Tin
Packaging Type	Reel
Plating min: Mating (µin)	35
Plating min: Mating (µm)	0.88
Plating min: Termination (µin)	35
Plating min: Termination (µm)	0.88
Termination Interface: Style	Crimp or Compression
Wire Insulation Diameter	0.90-1.80mm (.035-.071")
Wire Size AWG	22, 24, 26, 28
Wire Size mm²	N/A

Electrical

Current - Maximum per Contact	9A
Voltage - Maximum	600V

Material Info

Old Part Number	5558T2
-----------------	--------

Reference - Drawing Numbers

Packaging Specification	PK-5558-001, SPK-5558-001
Product Specification	PS-51010-005, PS-51010-006, PS-51096-001, PS-52034-003, PS-52034-004, PS-5556-001, PS-5556-002, PS-5556-003, RPS-30067-002
Sales Drawing	SD-5558****
Test Summary	TS-5556-002

EU RoHS

ELV and RoHS Compliant
REACH SVHC Contains SVHC: No
Halogen-Free Status
Halogen-Free

China RoHS



Need more information on product environmental compliance?

Email productcompliance@molex.com
 For a multiple part number RoHS Certificate of Compliance, [click here](#)

Please visit the [Contact Us](#) section for any non-product compliance questions.

Search Parts in this Series

5558Series

Mates With

5556 Mini-Fit™ Crimp Terminal

Use With

5559 Mini-Fit Jr.™ Plug Housing, 30068 Mini-Fit TPA™ Plug Housing, 42475 Mini-Fit BMI™ Plug Housing

Application Tooling | FAQ

Tooling specifications and manuals are found by selecting the products below. Crimp Height Specifications are then contained in the Application Tooling Specification document.

Global

Description	Product #
Hand Crimp Tool for Mini-Fit Jr.™ Crimp Terminals	0638191000
FineAdjust™ Applicator	0639002700

T2 Terminator Tooling Die	<u>0639102700</u>
FineAdjust for Mini-Fit Jr.™ Crimp Terminals	<u>0639020200</u>
T2 Terminator for Mini-Fit Jr.™ Crimp Terminals	<u>0639120200</u>
Extraction Tool	<u>0011030044</u>

Japan

Description	Product #
Hand Extraction Tool	<u>0570316000</u>
Applicator for M211A Bench Press, 22-28 AWG, for 5556T2/5558T2/50840/50841 Crimp Terminal	<u>0570383000</u>

This document was generated on 06/08/2010

PLEASE CHECK WWW.MOLEX.COM FOR LATEST PART INFORMATION

NOTES

1. MATERIAL: SEE CHART
2. FINISH: SEE CHART
3. PRODUCT SPECIFICATION: PS-5556-001, PS-5556-002, PS-5556-003
4. PACKAGING SPECIFICATION: PK-5558-001 FOR CHAIN
PK-5556-003 FOR LOOSE
5. MATES WITH TERMINAL: 5556 SERIES.
6. APPLICABLE HOUSING: 5559, 30068, 42475 SERIES.
7. THE NUMBER OF SERRATIONS TO BE ONE FOR WIRE RANGE #22-28.
8. WHEN TERMINALS ARE INSTALLED IN THE HOUSING THE WIRES ARE TO BE DRESSED IN SUCH A MANNER TO ALLOW THE TERMINALS TO FLOAT FREELY IN THE POCKET.
9. THIS TERMINAL IS DESIGNED FOR SINGLE WIRE CRIMPING.
10. PART CONFORMS TO CLASS "B" REQUIREMENTS OF COSMETIC SPECIFICATION PS-45499-002.

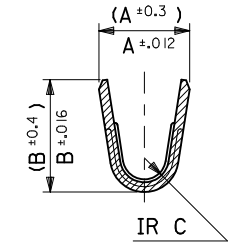
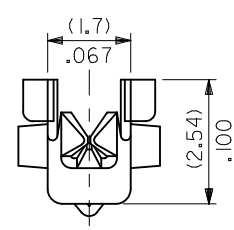
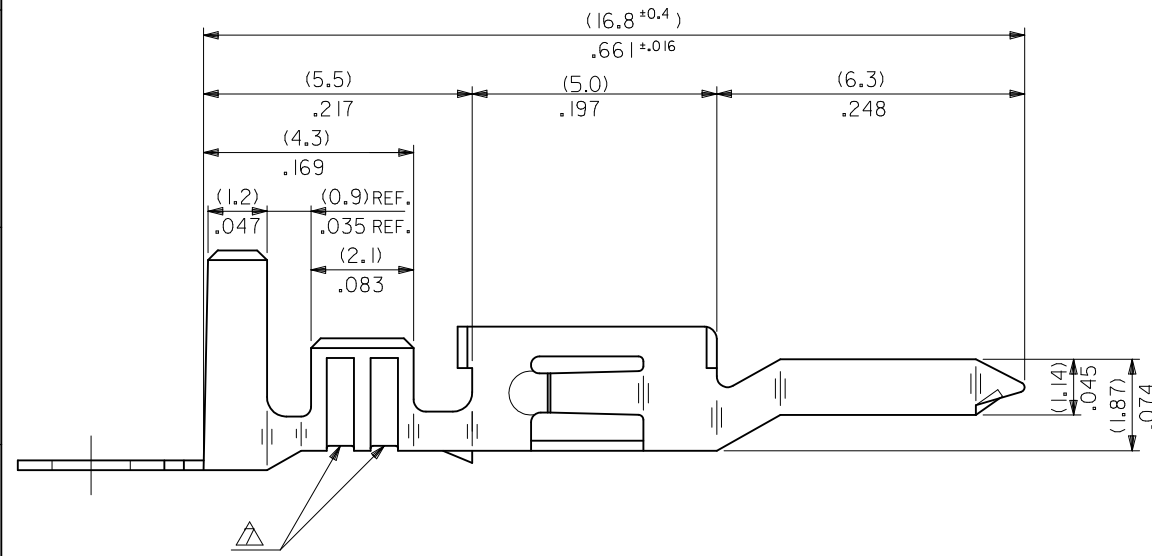
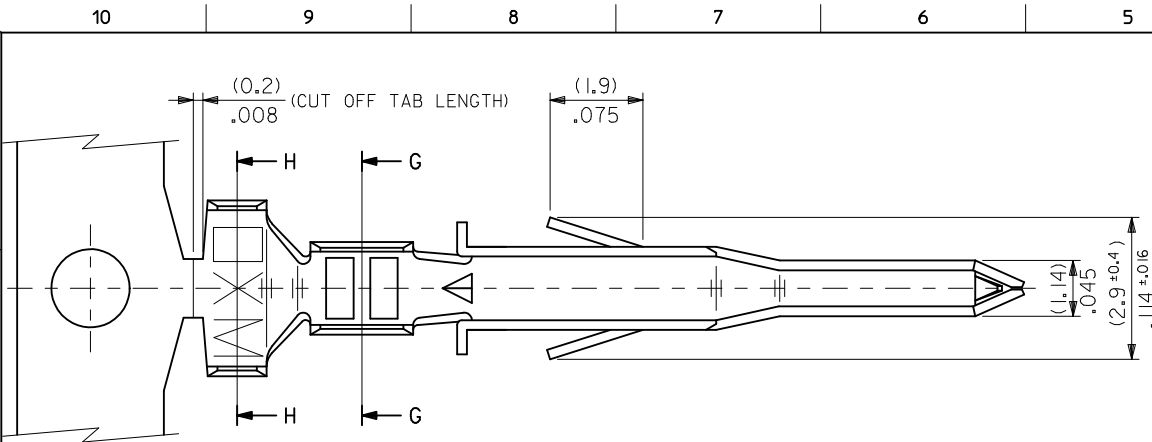

SECT. G-G

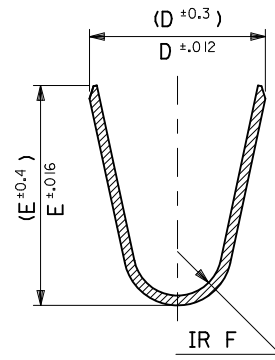

SECT. H-H

UPDATED NOTES EC NO: UCP2010-2478 DRWN: J JAGUILAR 2010/04/06 CHKD: JBELL 2010/04/09 APPR: F SMITH 2010/04/09	DESCRIPTION REV	QUALITY SYMBOLS	GENERAL TOLERANCES (UNLESS SPECIFIED)	DIMENSION STYLE	SCALE	DESIGN UNITS	THIRD ANGLE PROJECTION	
		$\nabla F=0$ $\nabla E=0$ $\nabla E=0$	mm INCH 4 PLACES ± --- ± --- 3 PLACES ± --- ± .008 2 PLACES ± .20 ± .008 1 PLACE ± .2 ± --- ANGULAR ± 3 °	MM/IN	10:1	METRIC	DRAWN BY H.HIRAMOTO DATE 1991/03/12 CHECKED BY S.KUNISHI DATE 1998/07/07 APPROVED BY P.S.MURAKUSHIMA DATE 1998/07/07	TITLE MINI-FIT JR OVERALL TIN MALE CRIMP TERMINAL
		DRAFT WHERE APPLICABLE MUST REMAIN WITHIN DIMENSIONS	SEE CHART	MATERIAL NO. SIZE B	DOCUMENT NO. SD-5558****	SHEET NO. 1 OF 2		
		THIS DRAWING CONTAINS INFORMATION THAT IS PROPRIETARY TO MOLEX INCORPORATED AND SHOULD NOT BE USED WITHOUT WRITTEN PERMISSION						

10 9 8 7 6 5 4 3 2 1

TIN PLATED PHOSPHOR BRONZE	(0.9) .035	(4.5) .177	(3.6) .142	(0.6) .024	(2.7) .106	(2.3) .091	∅ (3.1) .122 MAX.	# 16	39-00-0084	5558 PBT3L	LOOSE
	(0.6) .024	(2.3) .091	(2.3) .091	(0.4) .016	(1.65) .065	(1.8) .071	∅ (0.9-1.8) .035-.071	#22-28	↑ -0083	↑ PBT3	CHAIN
	(0.9) .035	(4.5) .177	(3.6) .142	(0.5) .020	(2.3) .091	(1.9) .075	∅ (1.3-3.1) .051-.122	#18-24	↑ -0068	↑ PBT2L	LOOSE
TIN OVER COPPER PLATED BRASS	(0.9) .035	(4.5) .177	(3.6) .142	(0.6) .024	(2.7) .106	(2.3) .091	∅ (3.1) .122 MAX.	# 16	-0067	PBT2	CHAIN
	(0.6) .024	(2.3) .091	(2.3) .091	(0.4) .016	(1.65) .065	(1.8) .071	∅ (0.9-1.8) .035-.071	#22-28	-0062	PBTL	LOOSE
	(0.9) .035	(4.5) .177	(3.6) .142	(0.5) .020	(2.3) .091	(1.9) .075	∅ (1.3-3.1) .051-.122	#18-24	-0061	PBT	CHAIN
MATERIAL	F	E	D	C	B	A	INS. RANGE	WIRE RANGE	EDP NO.	ENG. NO.	FORM

UPDATE TITLE BLOCK EC NO: UCP2010-2478 DRWN: J JAGUILAR 2010/04/06 CHKD: JBELL 2010/04/09 APPR: FSMITH 2010/04/09	QUALITY SYMBOLS ∇=0 ∇=0 ∇=0	GENERAL TOLERANCES (UNLESS SPECIFIED) mm INCH 4 PLACES ± --- ± --- 3 PLACES ± --- ± .008 2 PLACES ± .20 ± .008 1 PLACE ± .2 ± --- ANGULAR ± 3 °	DIMENSION STYLE MM/IN DRAWN BY DATE H.HIRAMOTO 1991/03/12 CHECKED BY DATE S.KUNISHI 1998/07/07 APPROVED BY DATE FSMHUKUSHIMA 2010/07/09	SCALE 10:1 DESIGN UNITS METRIC THIRD ANGLE PROJECTION	TITLE MINI-FIT JR OVERALL TIN MALE CRIMP TERMINAL	MOLEX INCORPORATED DOCUMENT NO. SD-5558****	SHEET NO. 2 OF 2
	DRAFT WHERE APPLICABLE MUST REMAIN WITHIN DIMENSIONS		SEE CHART	THIS DRAWING CONTAINS INFORMATION THAT IS PROPRIETARY TO MOLEX INCORPORATED AND SHOULD NOT BE USED WITHOUT WRITTEN PERMISSION			

9 8 7 6 5 4 3 2 1