

PLEASE CHECK WWW.MOLEX.COM FOR LATEST PART INFORMATION

Part Number: **0039000083**
Status: **Active**
Overview: [minifit_jr](#)
Description: 4.20mm (.165") Pitch Mini-Fit™ Crimp Terminal, Male, Phosphor Bronze, Tin (Sn), 16 AWG, Reel

Documents:

Test Summary (PDF)	Product Specification PS-5556-002 (PDF)
Drawing (PDF)	Product Specification PS-5556-003 (PDF)
Product Specification PS-5556-001 (PDF)	RoHS Certificate of Compliance (PDF)

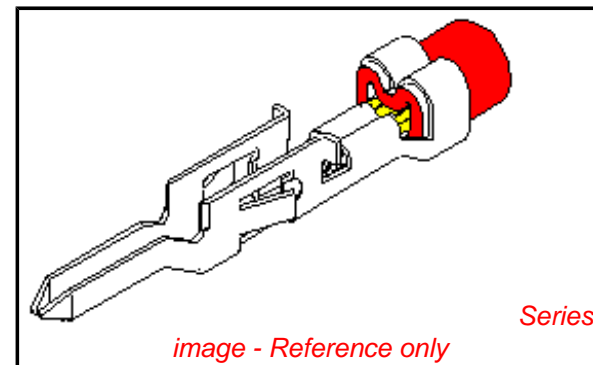

General

Product Family	Crimp Terminals
Series	5558
Crimp Quality Equipment	Yes
Overview	minifit_jr
Product Name	Mini-Fit®

Physical

Durability (mating cycles max)	30
Gender	Male
Material - Metal	Phosphor Bronze
Material - Plating Mating	Tin
Material - Plating Termination	Tin
Packaging Type	Reel
Plating min: Mating (µin)	36
Plating min: Mating (µm)	0.90
Plating min: Termination (µin)	36
Plating min: Termination (µm)	0.90
Termination Interface: Style	Crimp or Compression
Wire Insulation Diameter	1.80-3.10mm (.071-.122")
Wire Size AWG	16
Wire Size mm²	N/A

Electrical

Current - Maximum per Contact	9A
Voltage - Maximum	600V

Material Info

Old Part Number	5558PBT3
-----------------	----------

Reference - Drawing Numbers

Packaging Specification	PK-5558-001
Product Specification	PS-5556-001, PS-5556-002, PS-5556-003
Sales Drawing	SD-5558****
Test Summary	TS-5556-002

EU RoHS

**ELV and RoHS
Compliant**
**REACH SVHC
Contains SVHC: No**
**Halogen-Free
Status**

China RoHS



**Need more information on product
environmental compliance?**

Email productcompliance@molex.com
 For a multiple part number RoHS Certificate of Compliance, [click here](#)

Please visit the [Contact Us](#) section for any non-product compliance questions.

Search Parts in this Series

5558Series

Mates With

5556 Mini-Fit™ Crimp Terminal

Use With

5559 Mini-Fit Jr.™ Plug Housing

Application Tooling | FAQ

Tooling specifications and manuals are found by selecting the products below. Crimp Height Specifications are then contained in the Application Tooling Specification document.

Global

Description	Product #
FineAdjust™ Applicator for Mini-Fit Jr.™, Mini-Fit HCS™ Crimp Terminals, 16 AWG and smaller insulation	0639015300
T2 Terminator Tooling Die	0639102800

FineAdjust™ Applicator	<u>0639002800</u>
FineAdjust™ Applicator	<u>0639003000</u>
T2 Terminator Tooling Die	<u>0639103000</u>
Extraction Tool	<u>0011030044</u>
Hand Crimp Tool for Mini-Fit™ Jr. Male and Female Crimp Terminals, 16-24 AWG	<u>0638190900</u>

This document was generated on 06/01/2010

PLEASE CHECK WWW.MOLEX.COM FOR LATEST PART INFORMATION

NOTES

1. MATERIAL: SEE CHART
2. FINISH: SEE CHART
3. PRODUCT SPECIFICATION: PS-5556-001, PS-5556-002, PS-5556-003
4. PACKAGING SPECIFICATION: PK-5558-001 FOR CHAIN
PK-5556-003 FOR LOOSE
5. MATES WITH TERMINAL: 5556 SERIES.
6. APPLICABLE HOUSING: 5559, 30068, 42475 SERIES.
7. THE NUMBER OF SERRATIONS TO BE ONE FOR WIRE RANGE #22-28.
8. WHEN TERMINALS ARE INSTALLED IN THE HOUSING THE WIRES ARE TO BE DRESSED IN SUCH A MANNER TO ALLOW THE TERMINALS TO FLOAT FREELY IN THE POCKET.
9. THIS TERMINAL IS DESIGNED FOR SINGLE WIRE CRIMPING.
10. PART CONFORMS TO CLASS "B" REQUIREMENTS OF COSMETIC SPECIFICATION PS-45499-002.

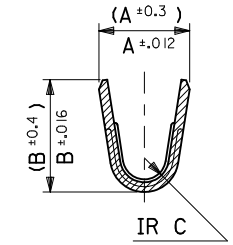
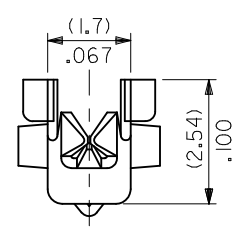
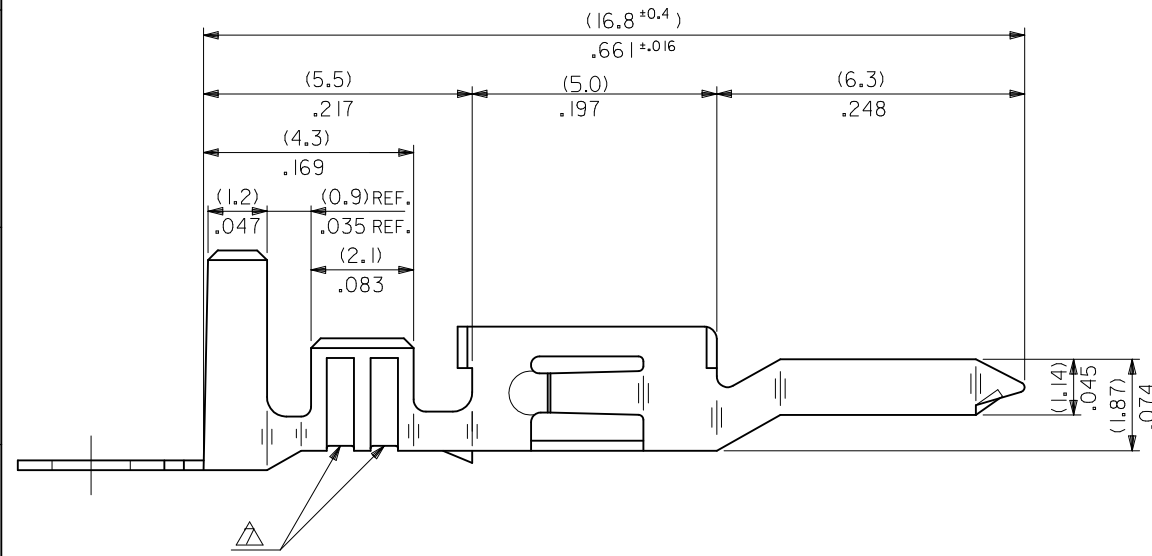
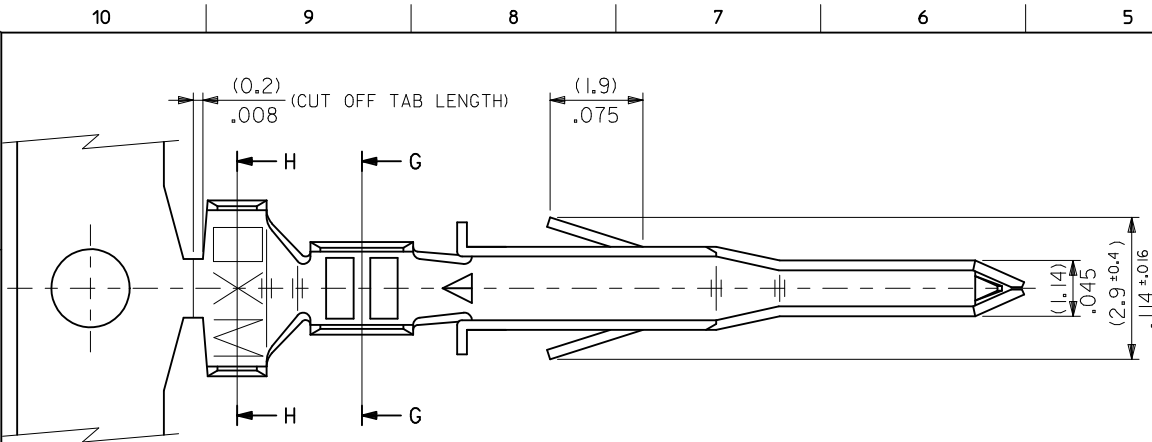

SECT. G-G

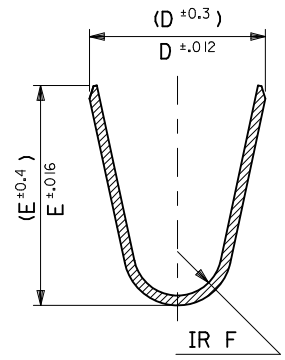

SECT. H-H

UPDATED NOTES EC NO: UCP2010-2478 DRWN: J JAGUILAR 2010/04/06 CHKD: JBELL 2010/04/09 APPR: F SMITH 2010/04/09	DESCRIPTION REV	QUALITY SYMBOLS	GENERAL TOLERANCES (UNLESS SPECIFIED)	DIMENSION STYLE	SCALE	DESIGN UNITS	THIRD ANGLE PROJECTION		
		$\nabla F=0$ $\nabla E=0$ $\nabla E=0$	mm INCH 4 PLACES ± --- ± --- 3 PLACES ± --- ± .008 2 PLACES ± .20 ± .008 1 PLACE ± .2 ± --- ANGULAR ± 3°	MM/IN	10:1	METRIC	DRAWN BY DATE H.HIRAMOTO 1991/03/12 CHECKED BY DATE S.KUNISHI 1998/07/07 APPROVED BY DATE P.S.MURAKUSHIMA 1998/07/07	TITLE	MINI-FIT JR OVERALL TIN MALE CRIMP TERMINAL
		DRAFT WHERE APPLICABLE MUST REMAIN WITHIN DIMENSIONS	SEE CHART	MATERIAL NO.	DOCUMENT NO.	MOLEX INCORPORATED SD-5558****		SHEET NO.	1 OF 2
		SIZE B	THIS DRAWING CONTAINS INFORMATION THAT IS PROPRIETARY TO MOLEX INCORPORATED AND SHOULD NOT BE USED WITHOUT WRITTEN PERMISSION						

10 9 8 7 6 5 4 3 2 1

TIN PLATED PHOSPHOR BRONZE	(0.9) .035	(4.5) .177	(3.6) .142	(0.6) .024	(2.7) .106	(2.3) .091	∅ (3.1) .122 MAX.	# 16	39-00-0084	5558 PBT3L	LOOSE
	(0.6) .024	(2.3) .091	(2.3) .091	(0.4) .016	(1.65) .065	(1.8) .071	∅ (0.9-1.8) .035-.071	#22-28	↑ -0083	↑ PBT3	CHAIN
	(0.9) .035	(4.5) .177	(3.6) .142	(0.5) .020	(2.3) .091	(1.9) .075	∅ (1.3-3.1) .051-.122	#18-24	-0068	PBT2L	LOOSE
TIN OVER COPPER PLATED BRASS	(0.6) .024	(2.3) .091	(2.3) .091	(0.4) .016	(1.65) .065	(1.8) .071	∅ (0.9-1.8) .035-.071	#22-28	-0067	PBT2	CHAIN
	(0.9) .035	(4.5) .177	(3.6) .142	(0.5) .020	(2.3) .091	(1.9) .075	∅ (1.3-3.1) .051-.122	#18-24	-0062	PBTL	LOOSE
	(0.6) .024	(2.3) .091	(2.3) .091	(0.4) .016	(1.65) .065	(1.8) .071	∅ (0.9-1.8) .035-.071	#22-28	-0061	PBT	CHAIN
MATERIAL	(0.9) .035	(4.5) .177	(3.6) .142	(0.6) .024	(2.7) .106	(2.3) .091	∅ (3.1) .122 MAX.	# 16	↑ -0082	T3L	LOOSE
	(0.6) .024	(2.3) .091	(2.3) .091	(0.4) .016	(1.65) .065	(1.8) .071	∅ (0.9-1.8) .035-.071	#22-28	-0081	T3	CHAIN
	(0.9) .035	(4.5) .177	(3.6) .142	(0.5) .020	(2.3) .091	(1.9) .075	∅ (1.3-3.1) .051-.122	#18-24	↓ -0049	T2L	LOOSE
	(0.6) .024	(2.3) .091	(2.3) .091	(0.4) .016	(1.65) .065	(1.8) .071	∅ (0.9-1.8) .035-.071	#22-28	-0048	T2	CHAIN
	(0.9) .035	(4.5) .177	(3.6) .142	(0.5) .020	(2.3) .091	(1.9) .075	∅ (1.3-3.1) .051-.122	#18-24	↓ -0041	TL	LOOSE
									39-00-0040	5558 T	CHAIN
	F	E	D	C	B	A	INS. RANGE	WIRE RANGE	EDP NO.	ENG. NO.	FORM

UPDATE TITLE BLOCK EC NO: UCP2010-2478 DRWN: J JAGUILAR 2010/04/06 CHKD: JBELL 2010/04/09 APPR: FSMITH 2010/04/09 REV DESCRIPTION	QUALITY SYMBOLS	GENERAL TOLERANCES (UNLESS SPECIFIED)	DIMENSION STYLE	SCALE	DESIGN UNITS	THIRD ANGLE PROJECTION
	▽ F/0	mm INCH	MM/IN	10:1	METRIC	
	▽ E/0	4 PLACES ± --- ± ---	DRAWN BY DATE	TITLE		
	▽ Z/0	3 PLACES ± --- ± .008	H.HIRAMOTO 1991/03/12	MINI-FIT JR OVERALL TIN MALE CRIMP TERMINAL		
	2 PLACES ± .20 ± .008	CHECKED BY DATE	MOLEX INCORPORATED			
	1 PLACE ± .2 ± ---	S.KUNISHI 1998/07/07	DOCUMENT NO. SD-5558****			
	ANGULAR ± 3 °	APPROVED BY DATE	SHEET NO. 2 OF 2			
		FSMITH/KUSHIMA 2010/07/09	THIS DRAWING CONTAINS INFORMATION THAT IS PROPRIETARY TO MOLEX INCORPORATED AND SHOULD NOT BE USED WITHOUT WRITTEN PERMISSION			
		MATERIAL NO.				
		SEE CHART				
		SIZE B				

9 8 7 6 5 4 3 2 1