

REVISION HISTORY			
REV	AUTH	DATE	DESCRIPTION
A	M.R.	8/9/2007	INITIAL RELEASE

1.05 MIN. SIZE
2 STD 0.110 THICK
FLANGES

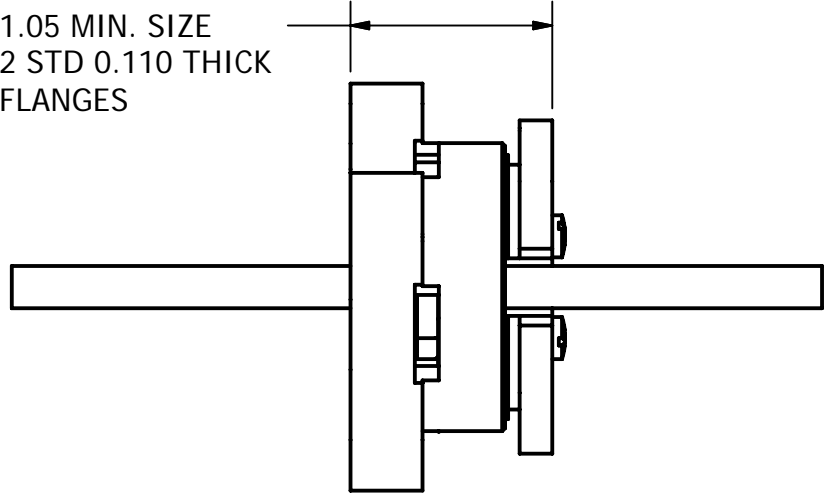

1.13 MAX. SIZE
2 PC 0.188 THICK
FLANGES

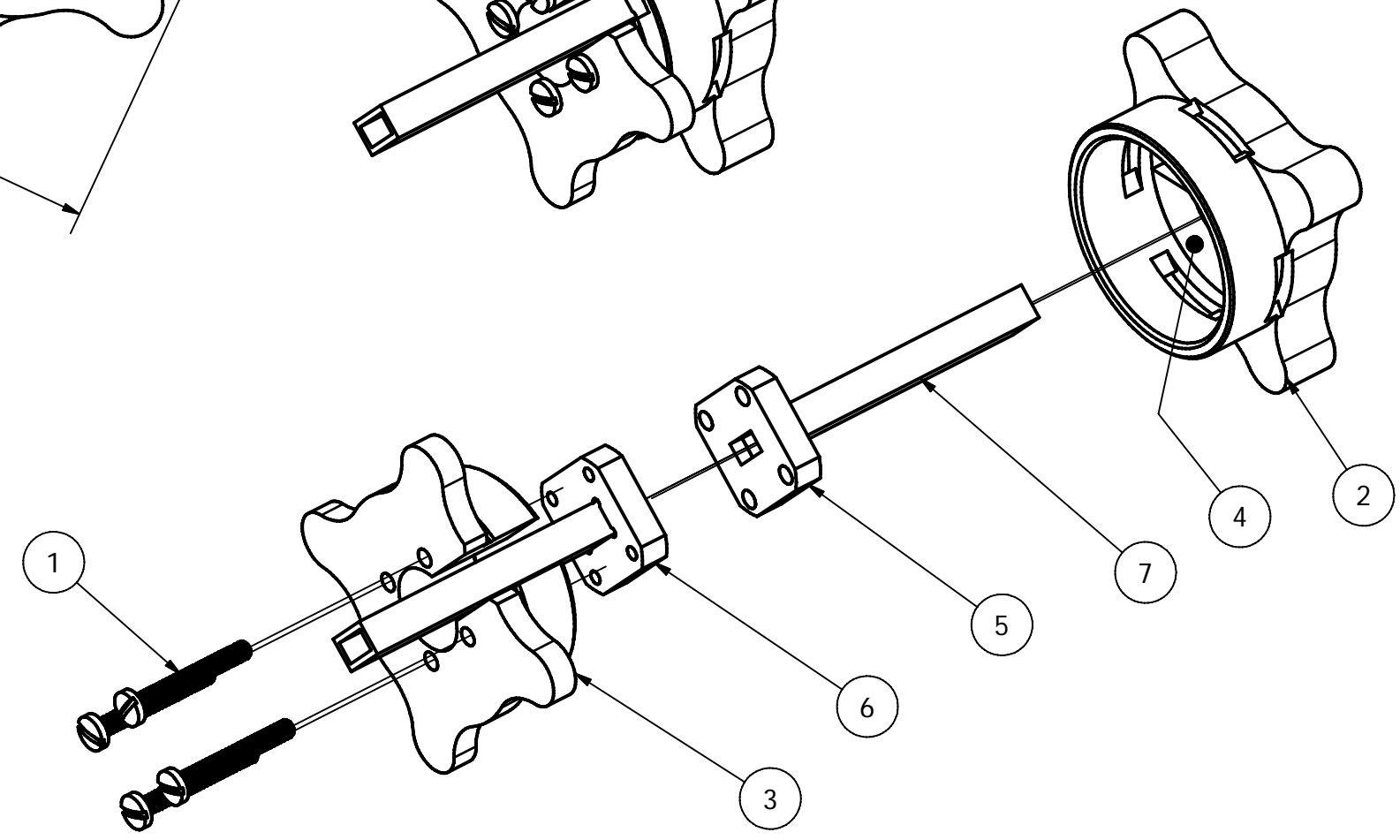
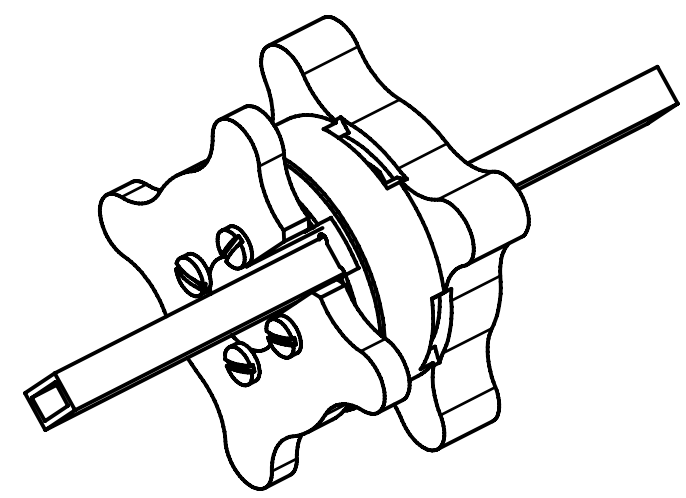
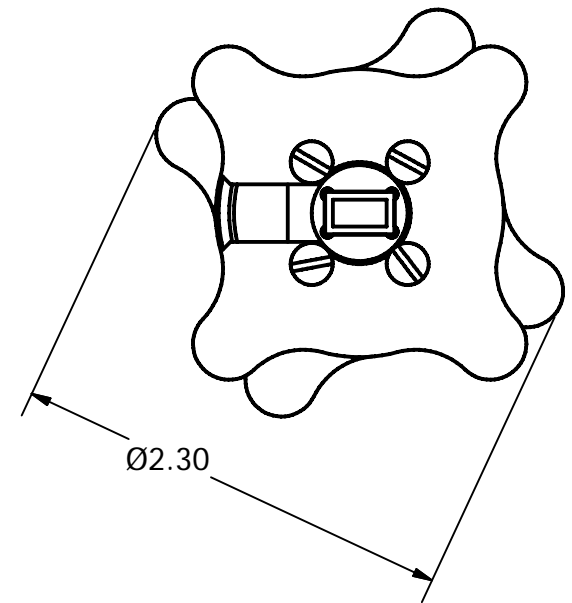
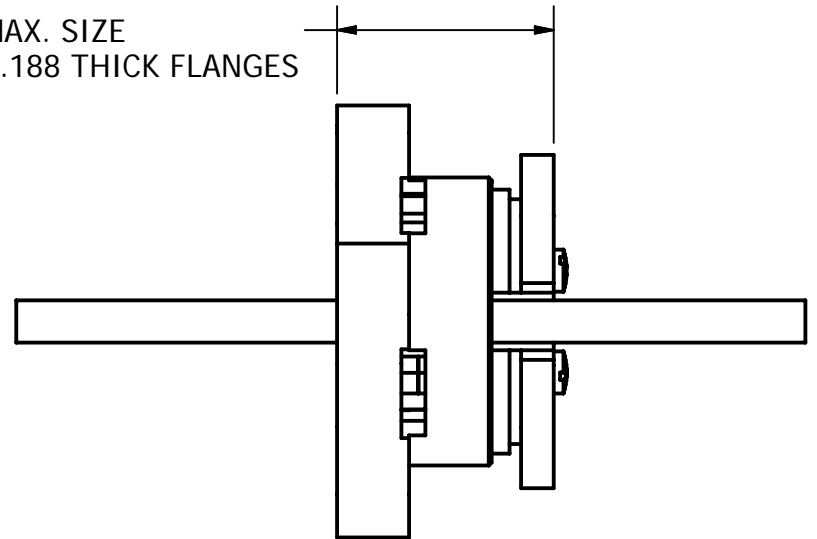

Parts List			
ITEM	QTY	PART NUMBER	DESCRIPTION
1	4	#6-32 x 0.875-UNC PH NYLON	
2	1	WR28QD FEMALE	TO BE CUT BY CUST FOR APP.
3	1	WR28QD MALE	
4	1	WR28QD RET. RING	
5	1	28_Cvr FLANGE	CUST SUPPLIED SHOWN FOR REF.
6	1	28_Cvr_THREADED 4-40 FLANGE	CUST SUPPLIED SHOWN FOR REF.
7	2	28_WAVE GUIDE	CUST SUPPLIED SHOWN FOR REF.

THIRD ANGLE PROJECTION:		APPROVALS	DATE	ADVANCED TECHNICAL MATERIALS, INC. TEL: (631) 289-0363 FAX: (631) 289-0358 www.atmmicrowave.com	<small>THE INFORMATION IN THIS DRAWING IS PROPRIETARY AND SHALL NOT BE USED OR DISCLOSED WITHOUT THE PRIOR WRITTEN CONSENT OF ATM, INC. DO NOT SCALE DWG.</small>
UNLESS OTHERWISE NOTED, DIMENSIONS ARE IN INCHES. TOLERANCES ARE: FRACTIONS: ±1/64 ANGLES: ±1/2°		DRAWN M.R.			
BASIC DIMENSION UNDER .6" ±.02 .6" to .12" ±.03 OVER .12" ±.06		DECIMALS 2 PLACE ±.005 3 PLACE ±.010 ±.015	APRVD.	WR28 QUICK CONNECT HIGH TORQUE	
MATERIAL 6061 ALUM		TREATMENT IRIDITE	FINISH NONE	SIZE B CAGE CODE 0R8N4 ATM DWG # 5449 REVISION A	MODEL # OD-28HQ SHEET 1