

PLEASE CHECK WWW.MOLEX.COM FOR LATEST PART INFORMATION

Part Number: **0191640312**
Status: **Active**
Description: Perma-Seal™ Ring Tongue Terminal for 14-16 AWG Wire, Stud Size 10, Mylar Tape Carrier

Documents:

[Drawing \(PDF\)](#) [RoHS Certificate of Compliance \(PDF\)](#)

Agency Certification

CSA LR18689
 UL E32244

General

Product Family Ring and Spade Terminals
 Series 19164
 Crimp Quality Equipment Yes
 Mil-Spec N/A
 Product Name Perma-Seal™
 Type Ring

Physical

Barrel Type Closed
 Flammability 94V-2
 Insulation NiAc™
 Material - Plating Mating Tin
 Packaging Type Adhesive Tape on Reel
 Stud Size 10 (M5)
 Wire Insulation Diameter 5.97mm (.235")
 Wire Size AWG 14, 16
 Wire Size mm² 1.23 - 1.94

Material Info

Old Part Number SB-237-10T

Reference - Drawing Numbers

Sales Drawing SD-19164-026

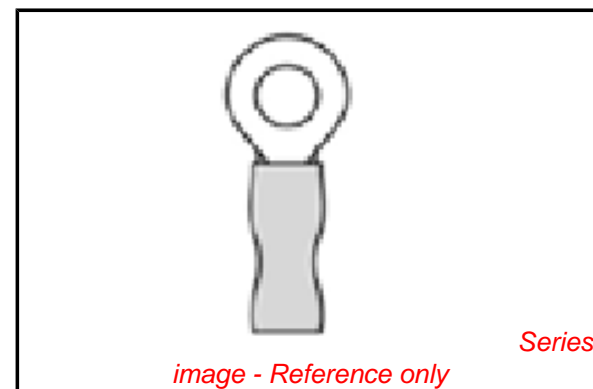

EU RoHS

ELV and RoHS Compliant
REACH SVHC
 Not Reviewed
Halogen-Free Status
 Not Reviewed

China RoHS



Need more information on product environmental compliance?

Email productcompliance@molex.com
 For a multiple part number RoHS Certificate of Compliance, [click here](#)

Please visit the [Contact Us](#) section for any non-product compliance questions.

Search Parts in this Series

[19164Series](#)

Application Tooling | [FAQ](#)

Tooling specifications and manuals are found by selecting the products below. Crimp Height Specifications are then contained in the Application Tooling Specification document.

Global

Description	Product #
Power Crimp Tool Head for Prema-Seal™ Terminals 10-22 AWG	0640057400
ATP Perishable Tool Kit Used in ATP Presses that Process Product on Tape	0198082012
Hand Crimp Tool, UL Approved	0640017400

PLEASE CHECK WWW.MOLEX.COM FOR LATEST PART INFORMATION

	13	12	11	10	9	8	7	6	5	4	3	2	1
	MATERIAL NUMBER	ENGINEERING NUMBER	MATERIAL NUMBER ON TAPE	ENGINEERING NUMBER ON TAPE	STUD SIZE	"S" ±.005/0.03	"D" MAX	"H" ±.010/0.25	"L" MAX	ID MIN			
J	191640031	SB-237-04	191640941	SB-237-04T	#4	.119/3.02	.320/8.17	.527/13.39	1.45/36.8	.082/2.08			
	191640032	SB-237-06	191640310	SB-237-06T	#6	.146/3.71	.320/8.17	.527/13.39	1.45/36.8	.082/2.08			
	191640033	SB-237-08	191640311	SB-237-08T	#8	.173/4.39	.320/8.17	.527/13.39	1.45/36.8	.082/2.08			
	191640034	SB-237-10	191640312	SB-237-10T	#10	.198/5.03	.320/8.17	.527/13.39	1.45/36.8	.082/2.08			
I	191640025	SB-225-10	191640940	SB-225-10T	#10	.198/5.03	.475/12.07	.338/8.59	1.63/41.4	.153/3.89			
	191640026	SB-225-14	191640308	SB-225-14T	1/4	.265/6.73	.475/12.07	.338/8.59	1.63/41.4	.153/3.89			
	191640027	SB-225-56	191640309	SB-225-56T	5/16	.328/8.33	.475/12.07	.338/8.59	1.63/41.4	.153/3.89			
	191640020	SB-218-38	191640307	SB-218-38T	3/8	.390/9.91	.475/12.07	.340/8.64	1.63/41.4	.153/3.89			

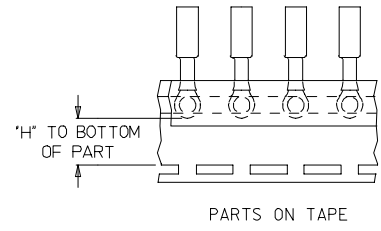
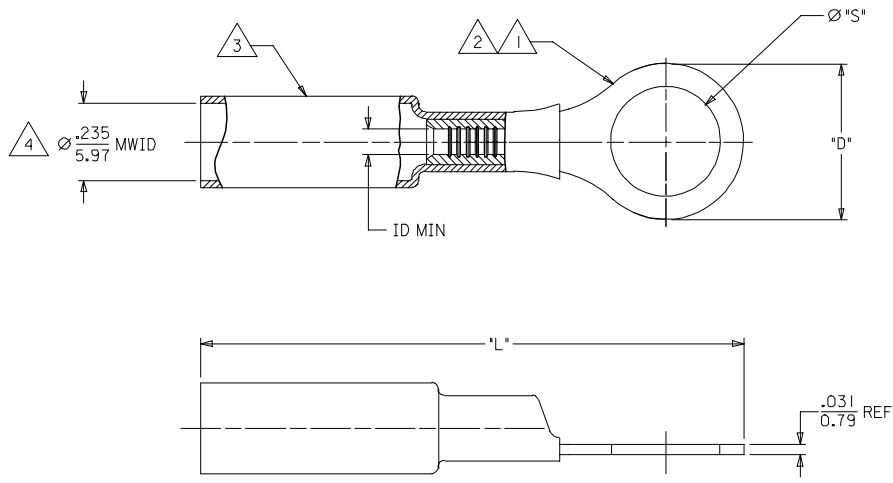

NOTE:

- 1. TERMINAL MATERIAL: COPPER ALLOY
- 2. FINISH: ELECTRO TIN PLATE.
- 3. INSULATION MATERIAL: HEAT SHRINKABLE TUBING WITH HOTMELT ADHESIVE INNER LINER. COLOR: BLUE
- 4. MWID = MAXIMUM WIRE INSULATION DIAMETER.

SALES DRAWING

REVISED TITLE BLOCK EC NO: ETC2006-0017 DRW: SHADECK 2005/07/25 CHK: RDEROSS 2005/07/26 APPR: RDEROSS 2005/07/27	QUALITY SYMBOLS ▽=0 ▽=0	GENERAL TOLERANCES (UNLESS SPECIFIED)		DIMENSION STYLE IN/MM		SCALE ---	DESIGN UNITS INCH	THIRD ANGLE PROJECTION		
		4 PLACES ± --- ± ---	3 PLACES ± --- ± ---	2 PLACES ± --- ± ---	1 PLACE ± --- ± ---	ANGULAR ± --- °	DRAWN BY BENDERLE	DATE 2002/08/26	TITLE RING TONGUE TERMINAL PERMA-SEAL NIAC 16-14 AWG	
		DRAFT WHERE APPLICABLE MUST REMAIN WITHIN DIMENSIONS		SEE CHART		APPROVED BY RDEROSS		DATE 2002/08/26	MATERIAL NO. SD-19164-026	
						MATERIAL NO. SD-19164-026		DOCUMENT NO. SD-19164-026		SHEET NO. 1 OF 1