

- CONTENTS -

1. Features
2. Outline dimensions
3. Package material
4. Absolute Maximum Ratings
5. Electrical Optical Characteristics
6. Ranks
7. Taping
8. Packing Structure
9. Characteristic Diagrams
10. Precautions to taken
11. Reliability
12. Precautions in use
13. Revision history sheet

## 1. Features

- Package : SMD package1000
- Colorless transparency
- 1.6×0.8×0.4 mm(L×W×H) small size surface mount type
- Wavelength : 525nm(P-Green)
- Viewing angle : extremely wide(160°)
- Technology : InGaN
- Soldering methods : IR reflow soldering
- Taping : 8 mm conductive black carrier tape & antistatic clear cover tape.  
5000pcs/reel, Φ180 mm wheel

## 2. Outline dimensions

(unit : mm)

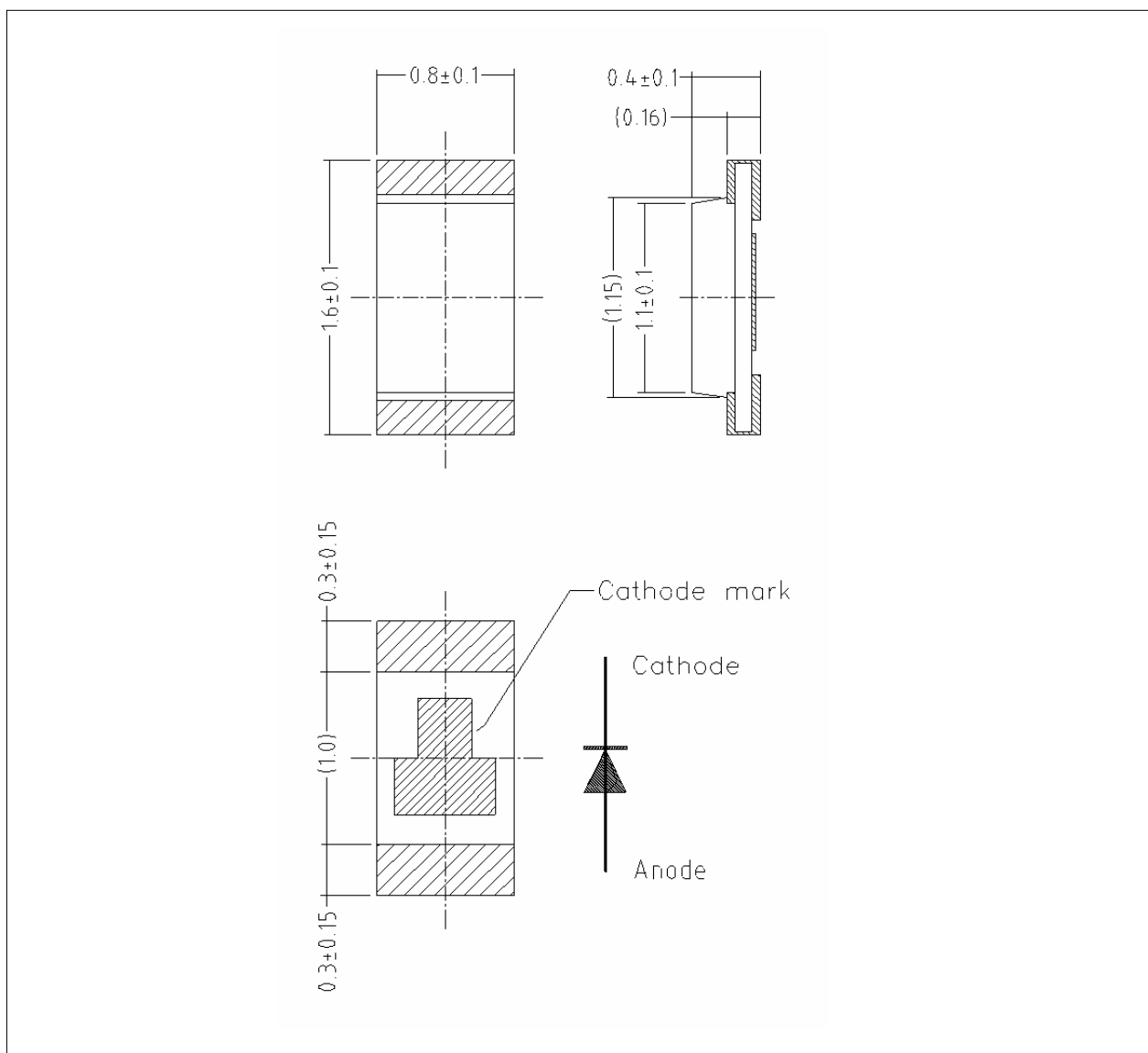

### 3. Package material

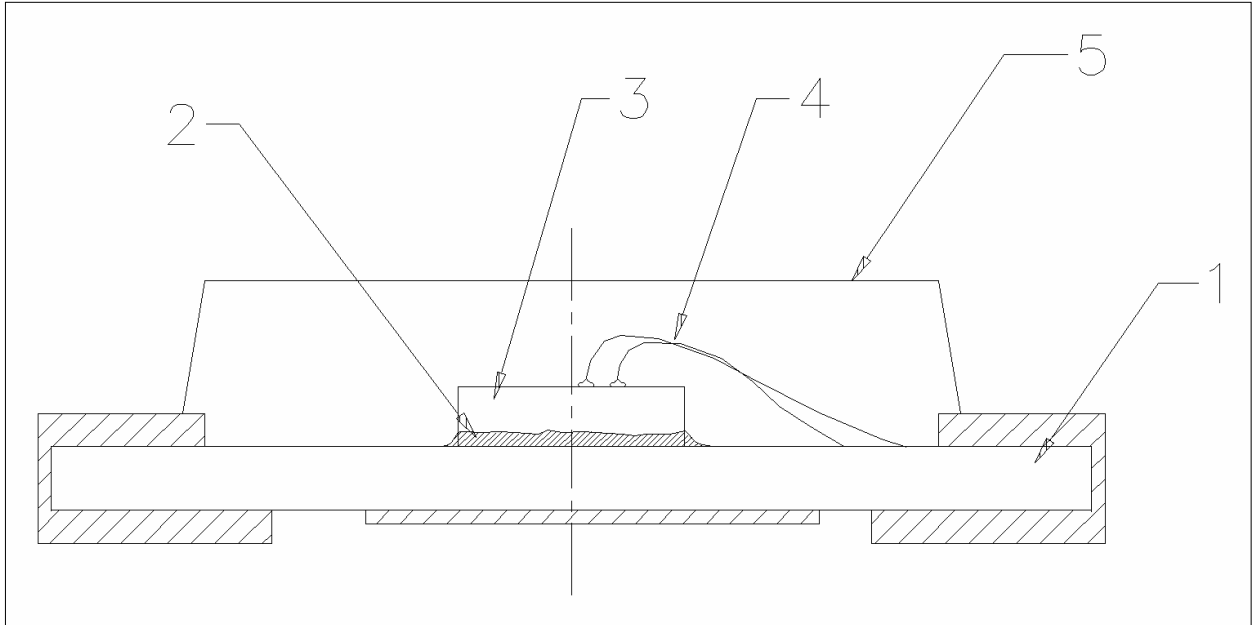

(1) Material construction

Number	Item	Material
1	PCB	C3965
2	Die adhesive	Epoxy
3	LED chip	GaN/Sapphire
4	Au wire	Wire
5	Mold epoxy	Epoxy

#### 4. Absolute Maximum Ratings

(Ta= 25°C)

Parameter	Symbol	Value	Unit
Power dissipation	$P_D$	70	mW
Forward Current	$I_F$	20	mA
* <sup>1</sup> Peak Forward Current	$I_{FP}$	100	mA
Reverse Voltage	$V_R$	5	V
Operating Temperature	$T_{opr}$	-30 ~ +85	°C
Storage Temperature	$T_{stg}$	-40 ~ +100	°C
* <sup>2</sup> Soldering Temperature	$T_{sol}$	245°C for 5 seconds	

\*1. Duty ratio 1/10, Pulse Width 10msec.

 \*2. Mounted on PC board FR4(pad size  $\geq 16 \text{ mm}^2$ )

#### 5. Electrical Optical Characteristics

(Ta = 25°C)

Characteristic	Symbol	Test Condition	Min.	Typ.	Max.	Unit
Forward Voltage	$V_F$	$I_F = 3\text{mA}$	2.6	-	3.0	V
		$I_F = 20\text{mA}$	3.0	-	3.6	
ESD Check Forward Voltage	$V_{F2}$	$I_F = 10\mu\text{A}$	1.8	-	-	V
Dominant Wavelength	$Wd$	$I_F = 3\text{mA}$	534	-	546	nm
Luminous intensity	$I_v$		28	-	80	mcd
Spectrum Bandwidth	$\Delta\lambda$		-	20	-	nm
Dominant Wavelength	$Wd$	$I_F = 20\text{mA}$	520	-	530	nm
Luminous intensity	$I_v$		110	-	300	mcd
Spectrum Bandwidth	$\Delta\lambda$		-	20	-	nm
Reverse Current	$I_R$	$V_R = 5\text{V}$	-	-	50	$\mu\text{A}$
* <sup>6</sup> Half Angle	$\theta_{1/2}$	$I_F = 20\text{mA}$	-	$\pm 80$	-	deg

 \*6.  $\theta_{1/2}$  is the off-axis angle where the luminous intensity is 1/2 the peak intensity.

**Different and Better**

## 6. Ranks

### (1) Dominant Wavelength

(Ta=25°C)

W <sub>D</sub> RANK	Test Condition	Min.	Typ.	Max.	Unit
A	I <sub>F</sub> = 3mA	534	–	540	nm
B		540	–	546	
C	I <sub>F</sub> = 20mA	520	–	525	nm
D		525	–	530	

\* Wavelength are tested at a current pulse duration 25ms and an accuracy of ±1 nm.

\* Wavelength(at IF=20mA) are only for reference.

### (2) Luminous intensity ranks

(Ta=25°C)

I <sub>v</sub> RANK	Test Condition	Min.	Typ.	Max.	Unit
D	I <sub>F</sub> = 3mA	28	–	40	mcd
E		40	–	56	
F		56	–	80	
H	I <sub>F</sub> = 20mA	110	–	150	
J		150	–	210	
K		210	–	300	

\* Luminous intensity is tested at a current pulse duration of 25 ms and an accuracy of ±11%.

Intensity Measured : 0.01sr(CIE. LED\_B)

\* Luminous intensity(at IF=20mA) are only for reference.

### (3) Forward Voltage

(Ta=25°C)

V <sub>F</sub> RANK	Test Condition	Min.	Typ.	Max.	Unit
0	I <sub>F</sub> = 3mA	2.60	–	2.70	V
1		2.70	–	2.80	
2		2.80	–	2.90	
3		2.90	–	3.00	
4	I <sub>F</sub> = 20mA	3.00	–	3.15	
5		3.15	–	3.30	
6		3.30	–	3.45	
7		3.45	–	3.60	

\* Voltages are tested at a current pulse duration of 1 ms and an accuracy of ±0.1V.

\* Voltages(at IF=20mA) are only for reference

### (4) Precautions On LED using

\* To avoid optical difference, Please do not mix differently-ranked product.

## 7. Taping

(1) Dimension of wheel((Material : PS Conductive, 10E9~12Ω)

(Unit : mm)

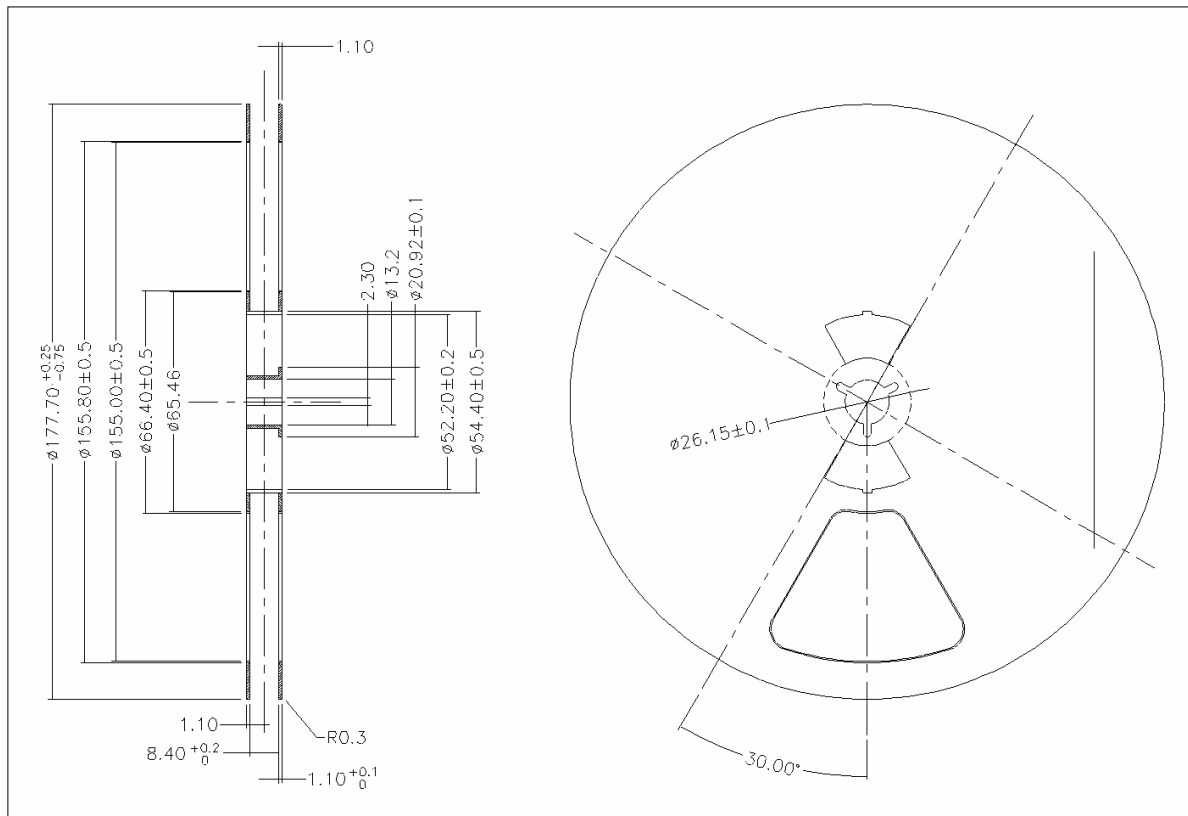

(2) Dimension of tape(Material : PS Conductive, 10E4~5Ω)

(Unit : mm)

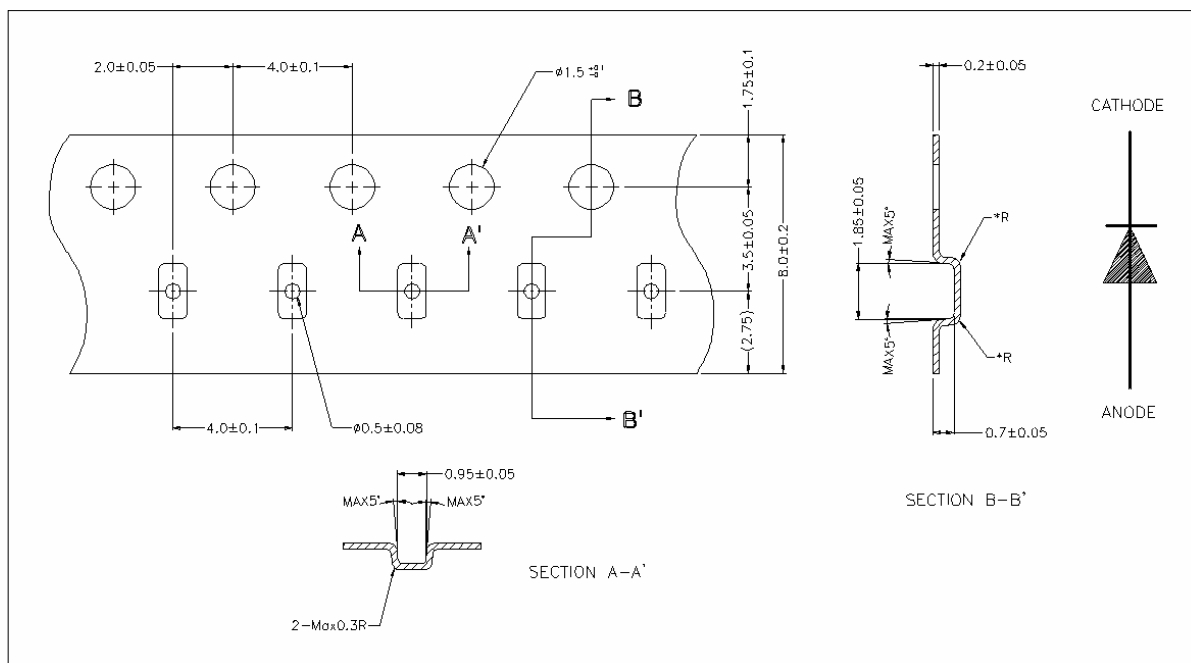

(3) Details of CHIP LEDs loading on tape

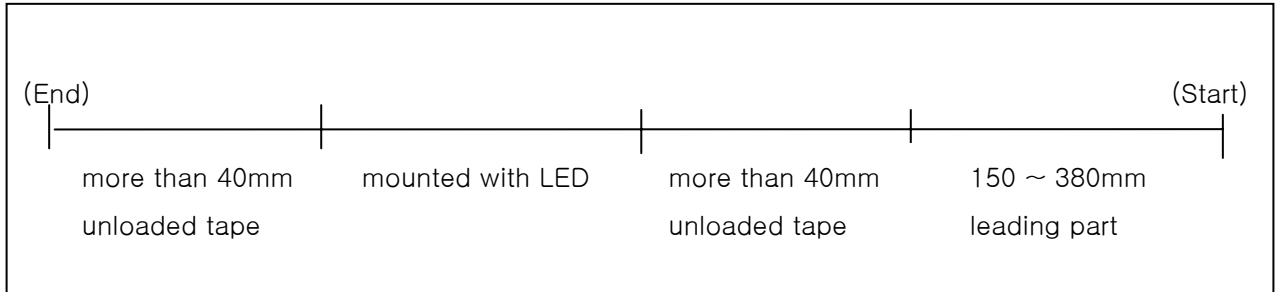

(4) Loading quantity per reel : 5,000pcs

## 8. Packing Structure

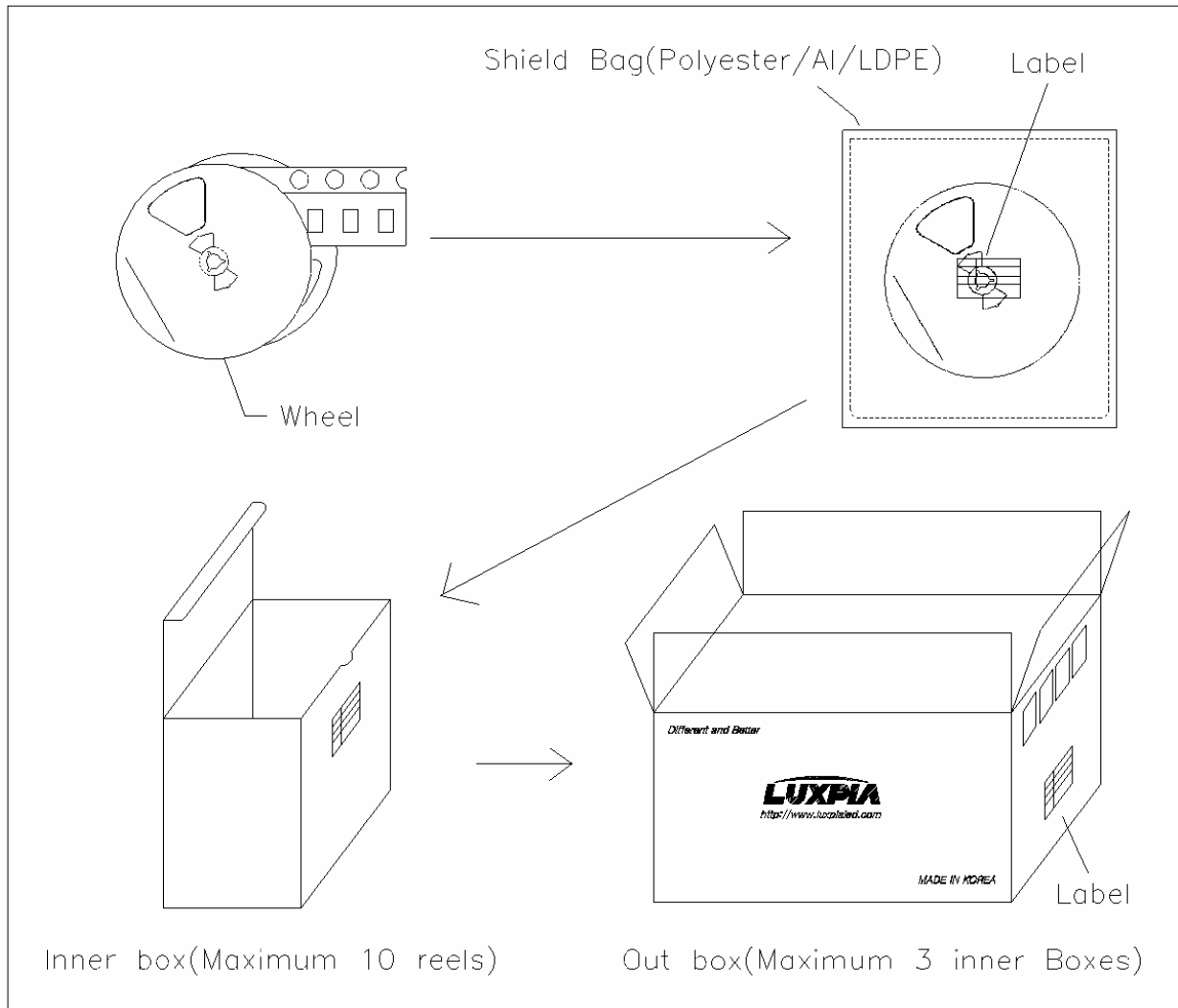



## ■ Characteristic Diagrams

Fig.1  $I_F$ - $V_F$  Relative Luminous Intensity vs Forward Current

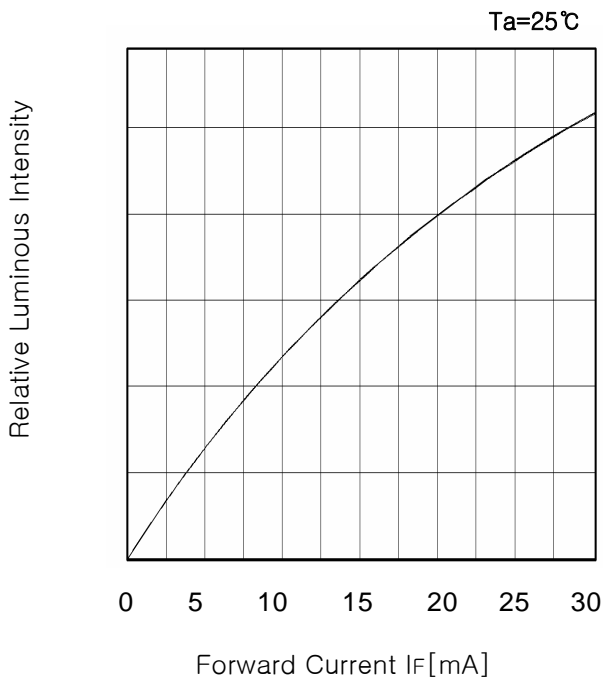

Fig.2  $I_V$ - $I_F$

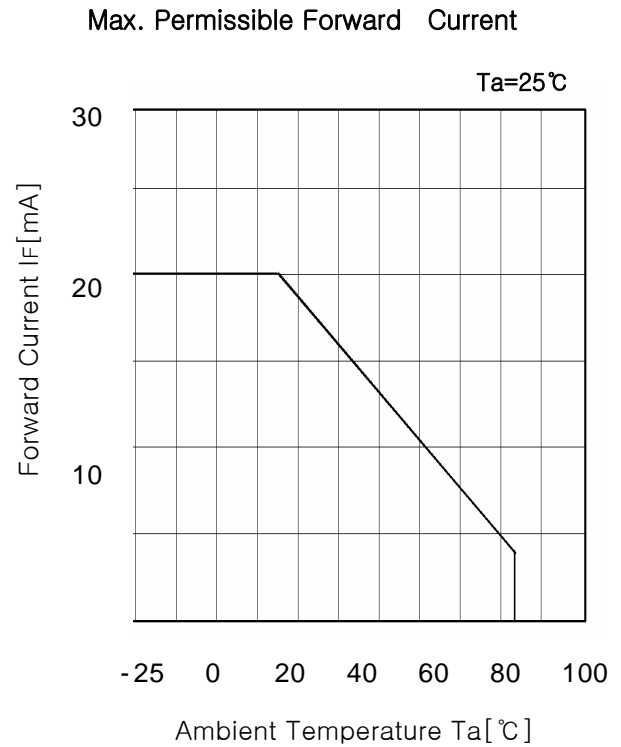

Fig.3 Forward Current vs. Forward Voltage

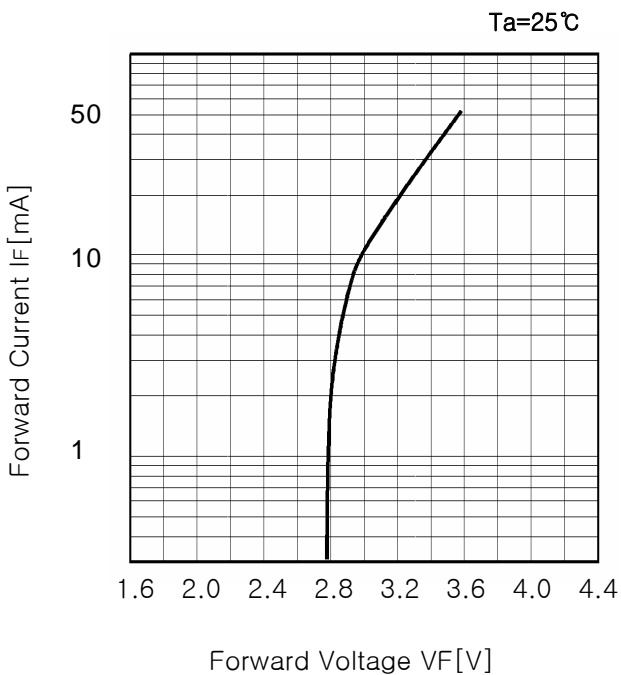

Fig. 4 Spectrum Distribution

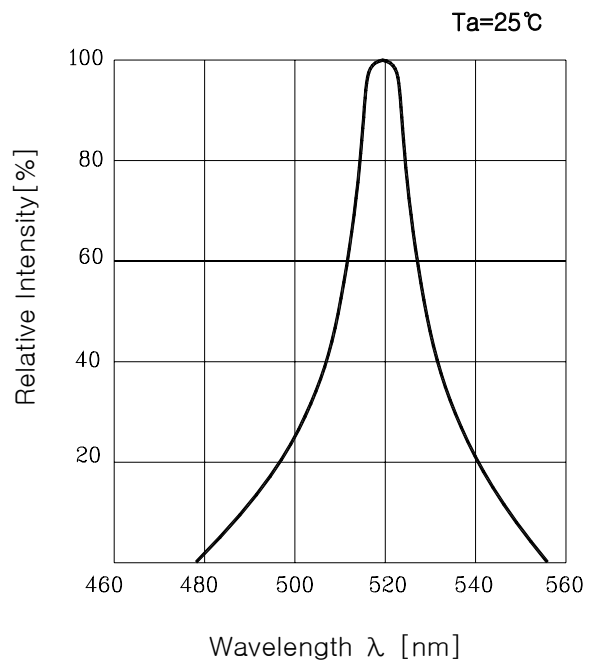

Fig. 5 Relative Spectral Emission

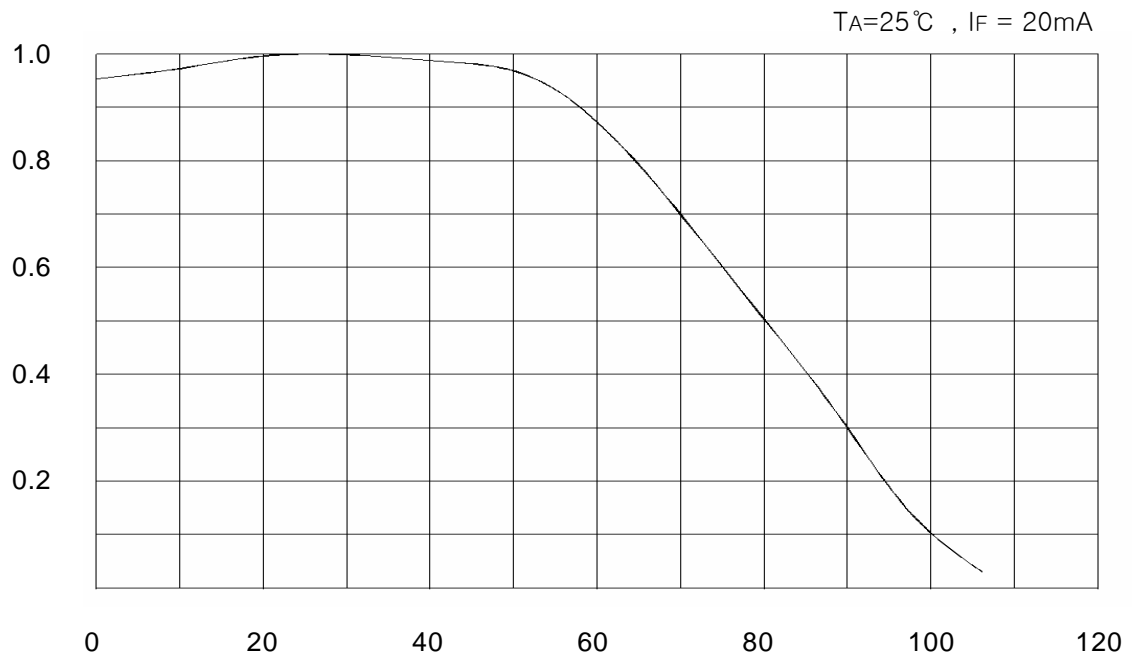
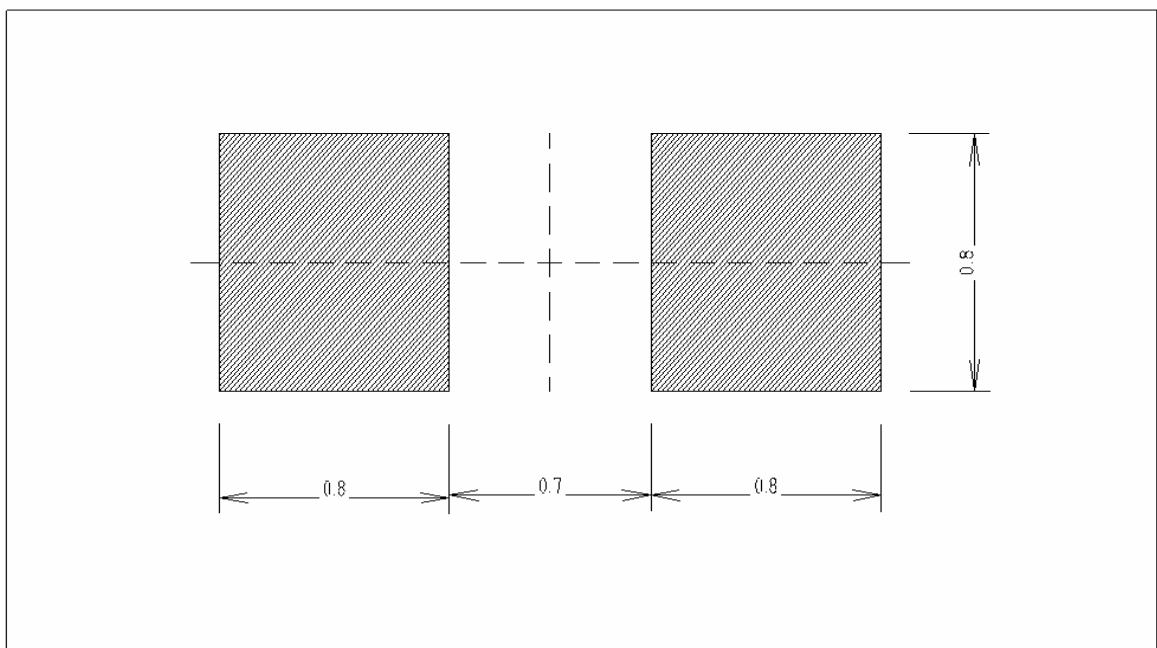
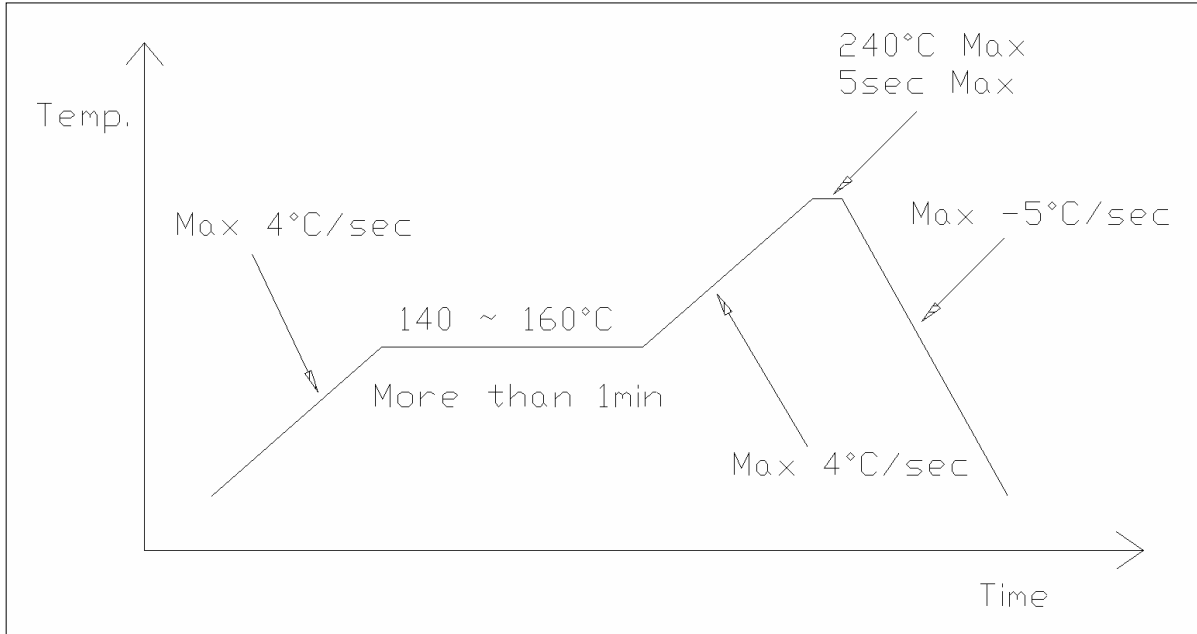

Fig.6 Recommended Solder Pad



## 10. Precautions to taken

### (1) Reflow soldering



### (2) For manual solder

Not more than 5sec @max $300^{\circ}\text{C}$ , under soldering iron

### (3) Recommendable soldering pattern(For reflow soldering)

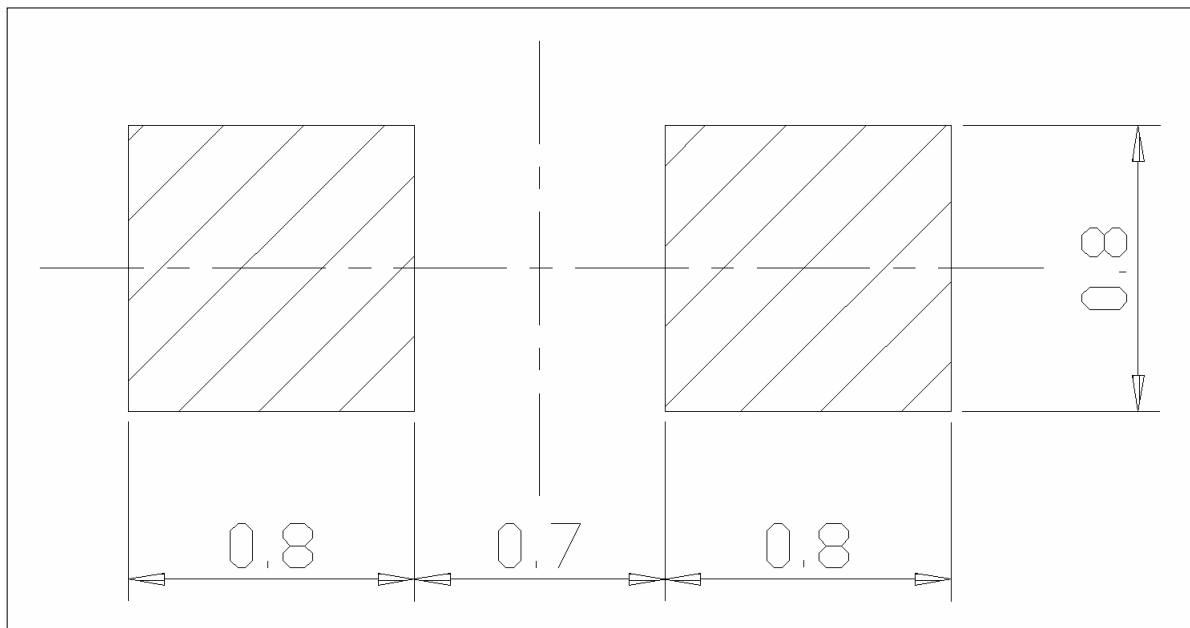

## 11. Reliability

(1) The Reliability criteria of SMD LED

ITEM	Symbol	Test Condition	Limit	
			Min.	Max.
Forward Voltage	V <sub>F</sub>	I <sub>F</sub> = 20mA	I.V × 0.8	I.V × 1.2
Reverse Current	I <sub>R</sub>	V <sub>R</sub> = 5V	LSL	-
Luminous intensity	I <sub>v</sub>	I <sub>F</sub> = 20mA	I.V × 0.7	I.V × 1.3

\* I : Initial Value    U : Upper Spec Limit    L : Lower Spec Limit

(2) Results of reliability Test

NO	Item	Test Conditions	Test Hours /Cycle	Sample Size	Ac/Re
1	Temperature Cycle	H : +100°C 30min ┆ 5min L : -30°C 30min	200 cycle	45 pcs	0/1
2	High Temperature Storage	TEMP : 80°C	1000HR's	45 pcs	0/1
3	Low Temperature Storage	TEMP : -30°C	1000HR's	45 pcs	0/1
4	DC Operating Life	I <sub>F</sub> : 20mA	1000HR's	45 pcs	0/1
5	High Temperature/ High Humidity	85°C/85% RH	1000HR's	45 pcs	0/1

## 12. Precautions in use

### (1) Soldering Conditions

- 1) When soldering, leave minimum clearance between the resin and the soldering point.
- 2) Maximum allowable soldering conditions  
Soldering dipping : 260 degrees C max., 5 seconds max., 1 time.  
Soldering iron : 350 degrees C max., 5 seconds max., 1 time, power 40w max.
- 3) Contact between molten solder and the resin must be avoided.
- 4) Correction the soldered position after soldering must be avoided.
- 5) In soldering, do not apply any stress to the lead frame, particularly when heated.
- 6) When other SMD parts on the same circuit board and adhesive is to be cured, maximum allowable conditions are : 120 degrees C max., 60 seconds max.

### (2) Lead forming and cut

- 1) Lead forming must be done below the tie bar cutting portion.
- 2) When forming a lead, do not stress the resin case.
- 3) Lead forming must be done before soldering.
- 4) Cutting the lead frame at high temperature may result in personal injury.  
Cut the lead frame at room temperature.

### (3) Assembly

- 1) Do not apply any stress to the lead frame while assembling.
- 2) When mounting products onto PCBs, the pitch between the mounting holes must match the pitch of the LEDs.

### (4) Static Electricity

- 1) These products are sensitive, a high standard of care must be used. Particularly if an over-current and over-voltage which exceeds the Absolute Maximum Rating of Products is applied, the overflow in energy may cause damage to, or possibly result in destruction of, the Products. Customer shall take absolutely secure countermeasures against static electricity and surge when handling Products.
- 2) A protection device should be installed in the LED driving circuit, which dose not exceed the max. rating for surge current during on/off switching.
- 3) Proper grounding of Products, use of conductive mat, semiconductive working uniform and shoes, and semiconductive containers are considered to be effective as countermeasures against static electricity and surge.

- 4) A soldering iron with a grounded tip is recommended. An ionizer should also be installed where risk of static generation is high.

#### **(5) Safety Precautions**

- 1) Users must comply with the laws and public regulations concerning safety.

The light output of the products may cause injuries to human eyes in circumstances where the products are viewed directly with unshielded eyes for more than a few seconds.

### 13. Revision history sheet

Spec NO.			
Title	Specification for Approval		
Times	Date	Summary of revision	Remarks
1	2002. 02. 08	신규제정	
2	2002. 05. 28	lv, WD, VF 수정 및 추가	
3	2004. 04. 19	VF 수정	