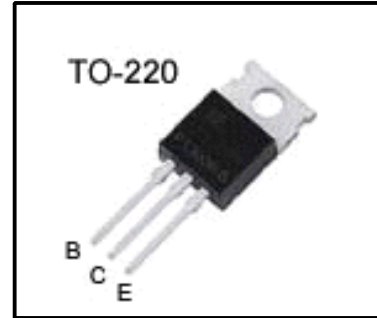


## *High Voltage Fast-Switching NPN Power Transistor*

### Features

- Very High Switching Speed
- High Voltage Capability
- Wide Reverse Bias SOA



### General Description

This Device is designed for high voltage, High speed Switching characteristics required such as lighting system, switching mode power supply.

### Absolute Maximum Ratings

Symbol	Parameter	Test Conditions	Value	Units
V <sub>CES</sub>	Collector -Emitter Voltage	V <sub>BE</sub> =0	700	V
V <sub>CEO</sub>	Collector -Emitter Voltage	I <sub>B</sub> =0	400	V
V <sub>EBO</sub>	Emitter-Base Voltage	I <sub>C</sub> =0	9.0	V
I <sub>C</sub>	Collector Current		12	A
I <sub>CP</sub>	Collector pulse Current		25	A
I <sub>B</sub>	Base Current		6.0	A
I <sub>BM</sub>	Base Peak Current	t <sub>p</sub> =5ms	12	A
P <sub>C</sub>	Total Dissipation at T <sub>c</sub> *=25℃		100	W
	Total Dissipation at T <sub>a</sub> *=25℃		2.2	
T <sub>J</sub>	Operation Junction Temperature		-40~150	℃
T <sub>STG</sub>	Storage Temperature		-40~150	℃

T<sub>c</sub> :Case temperature (good cooling)

T<sub>a</sub> :Ambient temperature (without heat sink)

### Thermal Characteristics

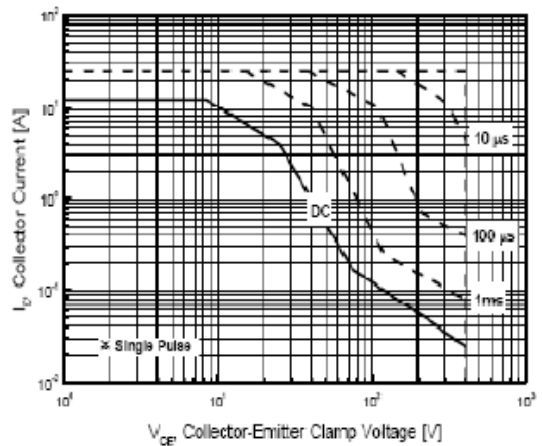
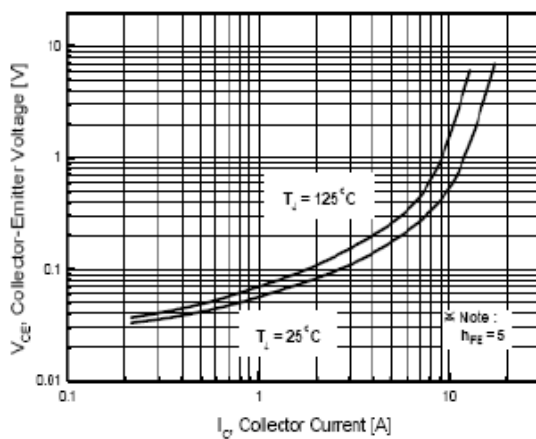
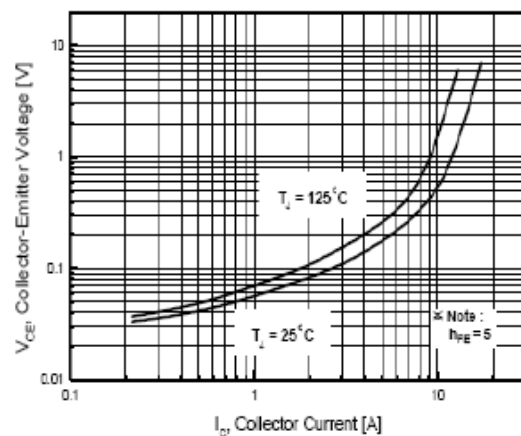
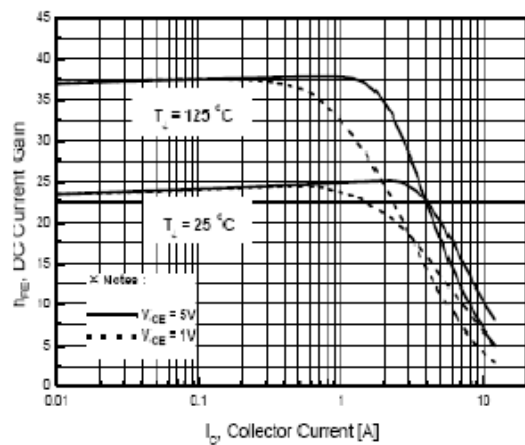
Symbol	Parameter	Value	Units
R <sub>θJC</sub>	Thermal Resistance Junction to Case	1.25	℃/W
R <sub>θJA</sub>	Thermal Resistance Junction to Ambient	40	℃/W

**Electrical Characteristics**( $T_c=25^\circ\text{C}$  unless otherwise noted)

Symbol	Parameter	Test Conditions	Value			Units
			Min	Typ	Max	
$V_{CEO(sus)}$	Collector–Emitter Breakdown Voltage	$I_c=10\text{mA}, I_b=0$	400	–	–	V
$V_{CE(sat)}$	Collector –Emitter Saturation Voltage	$I_c=5.0\text{A}, I_b=1.0\text{A}$ $I_c=8.0\text{A}, I_b=1.6\text{A}$ $I_c=12\text{A}, I_b=3.0\text{A}$	–	–	0.5 1.0 1.5	V
		$I_c=8.0\text{A}, I_b=1.6\text{A}$ $T_c=100^\circ\text{C}$	–	–	2.0	V
$V_{BE(sat)}$	Base –Emitter Saturation Voltage	$I_c=5.0\text{A}, I_b=1.0\text{A}$ $I_c=8.0\text{A}, I_b=1.6\text{A}$	–	–	1.2 1.6	V
		$I_c=8.0\text{A}, I_b=1.6\text{A}$ $T_c=100^\circ\text{C}$	–	–	1.5	V
$I_{CBO}$	Collector –Base Cutoff Current ( $V_{be}=-1.5\text{V}$ )	$V_{cb}=700\text{V}$ $V_{cb}=700\text{V}, T_c=100^\circ\text{C}$	–	–	1.0 5.0	mA
$h_{FE}$	DC Current Gain	$V_{ce}=5\text{V}, I_c=5.0\text{A}$ $V_{ce}=5\text{V}, I_c=8.0\text{A}$	10 6	– –	40 40	
$t_s$ $t_f$	<b>Resistive Load</b> Storage time Fall Time	$V_{CC}=125\text{V}, I_c=6.0\text{A}$ $I_{B1}=1.6\text{A}, I_{B2}=-1.6\text{A}$ $T_P=25\mu\text{s}$	–	1.5 0.17	3.0 0.4	$\mu\text{s}$
	<b>Inductive Load</b> Storage Time Fall Time	$V_{CC}=15\text{V}, I_c=5\text{A}$ $I_{B1}=1.6\text{A}, V_{be(off)}=5\text{V}$ $L=0.35\text{mH}, V_{clamp}=300\text{V}$ V	– –	0.8 0.04	2.0 0.1	$\mu\text{s}$
$t_s$ $t_f$	<b>Inductive Load</b> Storage Time Fall Time	$V_{CC}=15\text{V}, I_c=1\text{A}$ $I_{B1}=0.4\text{A}, V_{be(off)}=5\text{V}$ $L=0.2\text{mH}, V_{clamp}=300\text{V}$ $T_c=100^\circ\text{C}$	– –	0.8 0.05	2.5 0.15	$\mu\text{s}$

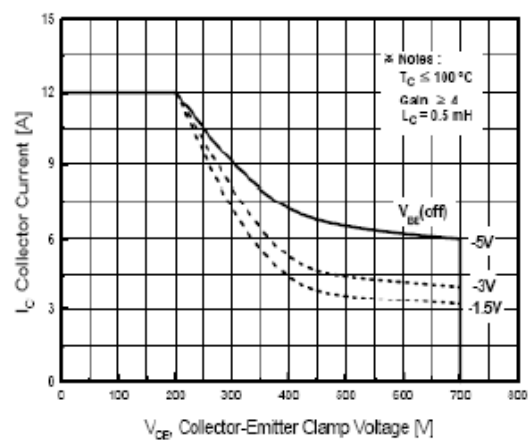
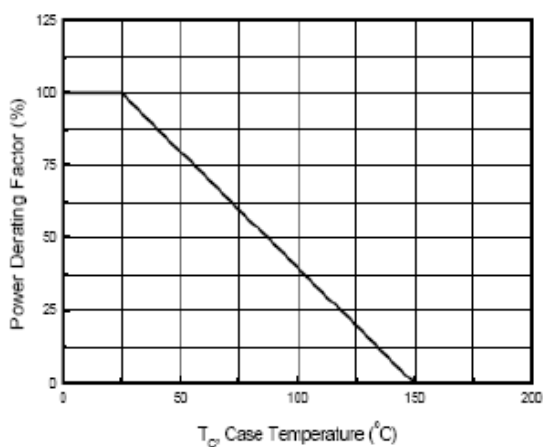
**Note:**

Pulse Test : Pulse Width300,Duty cycle 2%



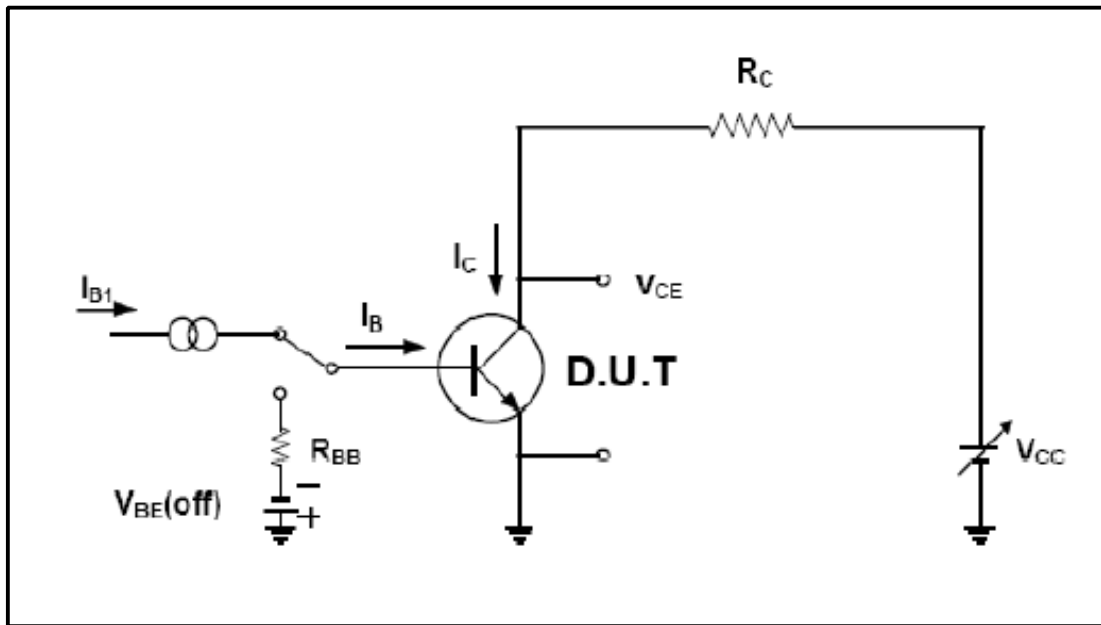
**Fig.3 Base-Emitter Saturation Voltage**

**Fig.4 Safe Operation Area**

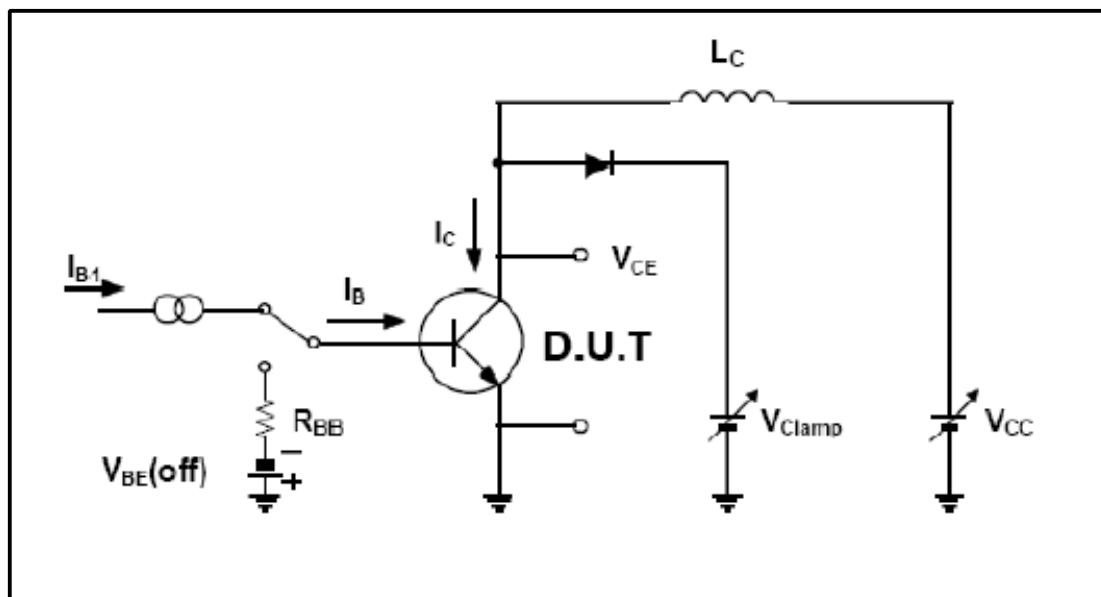


**Fig.5 Power Derating**

**Fig.6 Reverse Biased Safe Operation Area**



**Resistive Load Switching Test Circuit**



**Inductive Load Switching & RBSOA Test Circuit**

