

Customer Information Sheet

DRAWING No: M80-899XXXX SHEET 2 OF 2 IF IN DOUBT - ASK © NOT TO SCALE THIRD ANGLE PROJECTION ALL DIMENSIONS IN mm

2.00 x No. OF WAYS PER ROW + 3.15 MAX
2.00 x No. OF PITCHES PER ROW

COMMERCIAL ORDER CODE:
M80-899XXXX
TOTAL No. OF WAYS
02 - 07, 17
FINISH
01 - GOLD CLIP, TIN SHELL
05 - GOLD CLIP, GOLD SHELL
T6 - TIN CLIP, TIN SHELL

BRITISH STANDARD ORDER CODE: TO BS9525 F0033
B5740-1XX-F-D-X
TOTAL No. OF WAYS
02 - 07, 17
FINISH
0 - GOLD CLIP, TIN SHELL
2 - GOLD CLIP, GOLD SHELL

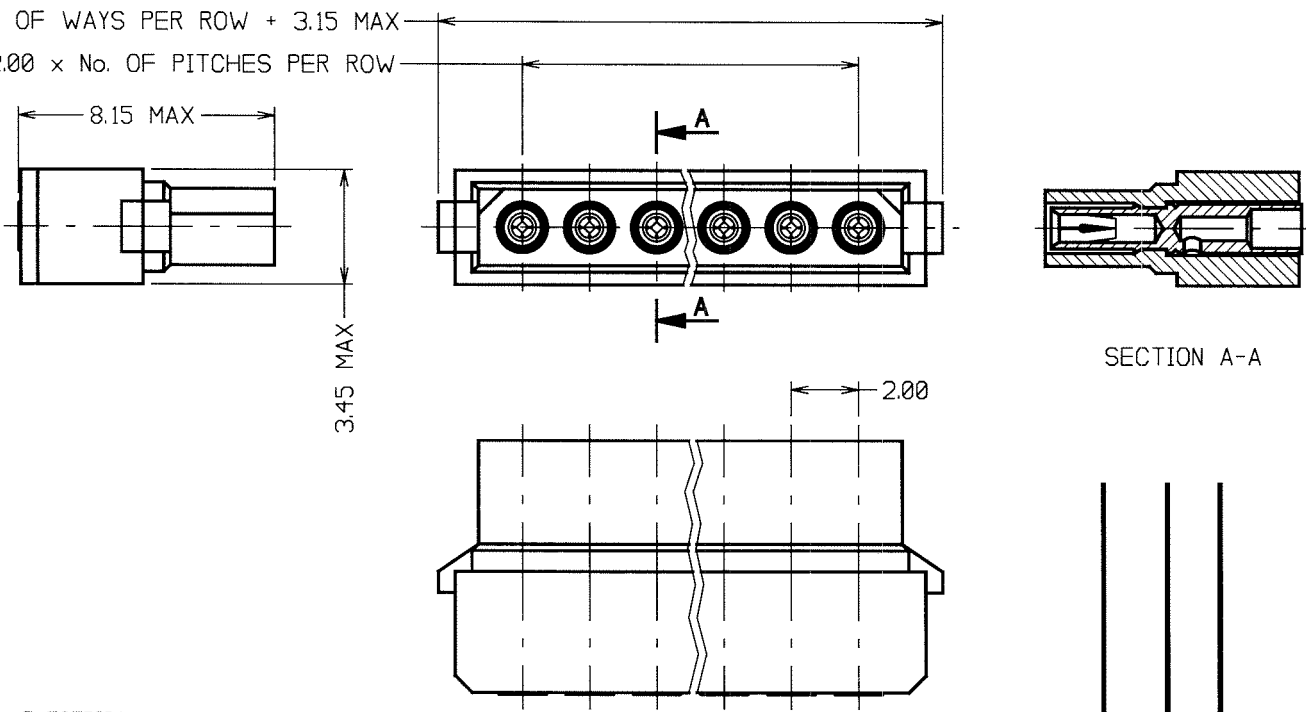

SPECIFICATIONS:

MATERIAL:
MOULDING - GLASS-FILLED POLYESTER UL94V-0
CLIP - BERYLLIUM COPPER
SHELL - BRASS
FINISH:
CONTACTS:
01 - 0.30µ GOLD CLIP, 4.0µ TIN SHELL
05 - 0.30µ GOLD CLIP, 0.28µ GOLD SHELL
T6 - 1.3µ 90/10 TIN/LEAD CLIP, 4.0µ TIN SHELL
MECHANICAL:
DURABILITY - 500 OPERATIONS
INSERTION FORCE - 2.8N MAX, 1.0N MIN
WITHDRAWAL FORCE - 1.8N MAX, 0.2N MIN
PACKING:
BAG (CONTACTS AND MOULDINGS UN-ASSEMBLED)
FOR COMPLETE SPECIFICATION, SEE COMPONENT SPECIFICATION C005XX (LATEST ISSUE)

ELECTRICAL:
CURRENT RATING AT 25°C - 3.0A MAX
CURRENT RATING AT 85°C - 2.2A MAX
WORKING VOLTAGE - 120V AC/DC
VOLTAGE PROOF - 360V AC/DC
CONTACT RESISTANCE (INITIAL) - 20 MILLIOHMS MAX
CONTACT RESISTANCE (AFTER CONDITIONING) = 25 MILLIOHMS MAX
INSULATION RESISTANCE (INITIAL) - 1000 MEGOHMS MIN
INSULATION RESISTANCE (AFTER CONDITIONING) = 100 MEGOHMS MIN
ENVIRONMENTAL:
TEMPERATURE RANGE = -55°C TO +125°C

NOTES:

1. RECOMMENDED WIRE TYPE = BS3G210 TYPE A, PTFE INSULATED, 22 AWG. MAX INSULATION DIAMETER = Ø1.10mm, STRIP WIRE BY 2.00mm.
2. RECOMMENDED HAND CRIMP TOOL = M22520/2-01 WITH POSITIONER T5747. ALSO AVAILABLE: PNEUMATIC AND ELECTRICAL CRIMP MACHINES.
3. CONTACT INSERTION & EXTRACTION TOOL = Z80-280
4. REFER TO INSTRUCTION SHEET FOR HAND CRIMP TOOL M22520/2-01 FOR COMPLETE CRIMPING INSTRUCTIONS.

JMB	10	11.07.05	8619
NAME	ISS.	DATE	C/NOTE
APPROVED: <i>[Signature]</i>			
CHECKED: <i>[Signature]</i>			
DRAWN:		W. J. BOURNE	
CUSTOMER REF.:			
ASSEMBLY DRG.:			



HARWIN USA TEL: 603 893 5376 FAX: 603 893 5396 mis@harwin.com
HARWIN Europe (UK) TEL: 023 9231 4545 FAX: 023 9231 4590 mis@harwin.co.uk
HARWIN Asia TEL: +65 6 779 4909 FAX: +65 6 779 3868 mis@harwin.com.sg

THIS DRAWING AND ANY INFORMATION OR DESCRIPTIVE MATTER SET OUT HEREON ARE CONFIDENTIAL AND COPYRIGHT PROPERTY OF THE HARWIN GROUP AND MUST NOT BE DISCLOSED, LOANED, COPIED OR USED FOR MANUFACTURING, TENDERING OR FOR ANY OTHER PURPOSE WITHOUT THEIR WRITTEN PERMISSION.

TOLERANCES
X. = ±1mm
X.X = ±0.25mm
X.XX = ±0.10mm
X.XXX = ±0.01mm
ANGLES = ±5°
UNLESS STATED

MATERIAL: SEE ABOVE
FINISH: SEE ABOVE
S/AREA: mm²

TITLE: DATAMATE 2mm PITCH CRIMP SIL SOCKET ASSEMBLY LARGE BORE (22 AWG)
DRAWING NUMBER: M80-899XXXX
SHT 2 OF 2