

**PLEASE CHECK WWW.MOLEX.COM FOR LATEST PART INFORMATION**

**Part Number:** [0945299106](#)  
**Status:** **Active**  
**Description:** 5.00mm (.197") Pitch RAST, Receptacle, Natural Color, PA Polyamide (Nylon) 6/6, 6 Circuits

**Documents:**

[Drawing \(PDF\)](#) [Product Specification PS-94529-002 \(PDF\)](#)  
[Product Specification PS-94529-001 \(PDF\)](#) [RoHS Certificate of Compliance \(PDF\)](#)

**Agency Certification**

UL E29179

**General**

Product Family Crimp Housings  
 Series [94529](#)  
 Product Name Pitch 5 Edge Card

**Physical**

Breakaway No  
 Circuits (maximum) 6  
 Color - Resin Natural  
 Flammability 94V-0  
 Gender Female  
 Glow-Wire Compliant No  
 Lock to Mating Part Yes  
 Material - Resin Nylon  
 Number of Rows 1  
 Packaging Type Bag  
 Panel Mount No  
 Pitch - Mating Interface (in) 0.197 In  
 Pitch - Mating Interface (mm) 5.00 mm  
 Pitch - Term. Interface (in) 0.197 In  
 Pitch - Term. Interface (mm) 5.00 mm  
 Polarized to Mating Part Yes  
 Stackable No  
 Temperature Range - Operating -40°C to +105°C, -40°C to +85°C

**Electrical**

Current - Maximum per Contact 6A

**Material Info**

**Reference - Drawing Numbers**

Product Specification PS-94529-001, PS-94529-002  
 Sales Drawing SD-94529-008

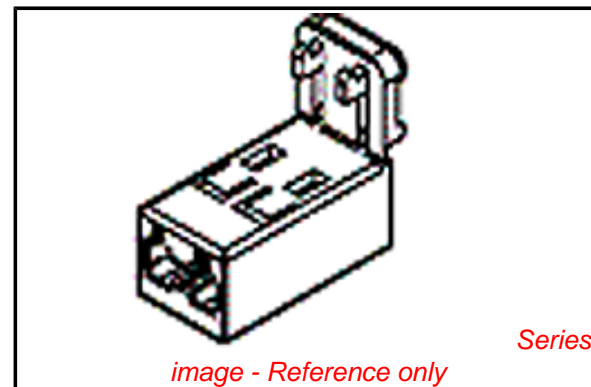

**EU RoHS**

**ELV and RoHS Compliant**  
**REACH SVHC Contains SVHC: No**  
**Halogen-Free Status**  
**Not Reviewed**

**China RoHS**



**Need more information on product environmental compliance?**

Email [productcompliance@molex.com](mailto:productcompliance@molex.com)  
 For a multiple part number RoHS Certificate of Compliance, [click here](#)

Please visit the [Contact Us](#) section for any non-product compliance questions.

**Search Parts in this Series**

[94529Series](#)

**Mates With**

PCB thickness 1.50mm (.059")

**Use With**

[94529-1203 Terminal](#)

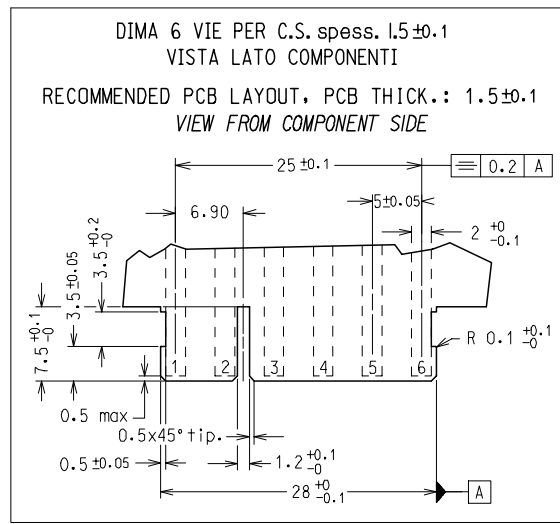
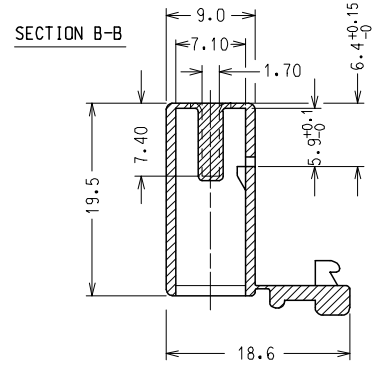
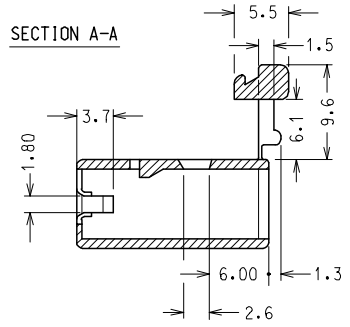

CODICE P/N	MATERIAL AND COLOR
94529-9106	NYLON 66 UL94 V2 NATURAL
94529-9206	NYLON 66 UL94 V2 BLACK
94529-7106	NYLON 66 UL94 V0 NATURAL
94529-7206	NYLON 66 UL94 V0 GREY
94529-4106	NYLON 6.6 GWT 750°C sec. IEC 60335-1 TEST METHOD IEC 60695-2-11 NATURAL

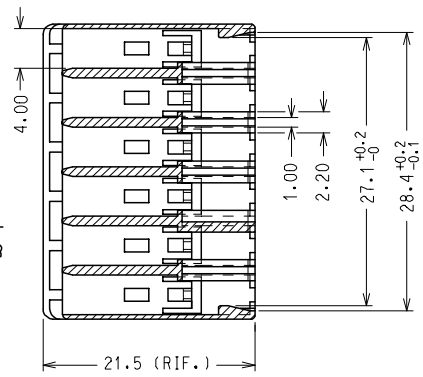
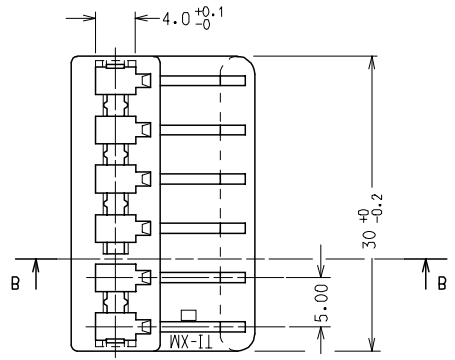
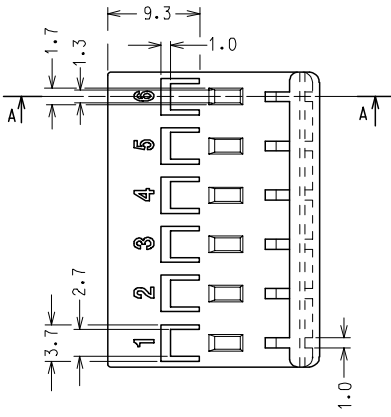

NOTA: LE DIMENSIONI VANNO MISURATE CON CORPI STABILIZZATI SECONDO NG 2301. (AUMENTO IN PESO DEL 2.7 %)

NOTE: PARTS SHALL BE DIMENSIONALLY CHECKED AFTER ATTAINING EQUILIBRIUM CONDITIONS E.G. 27 % INCREASE IN WEIGHT FOR HUMIDITY ABSORPTION FROM DRY STATUS.

CARATTERISTICHE PRODOTTO SECONDO PS-94529  
PRODUCT CHARACTERISTICS ACCORDING TO PS-94529 E

CONFEZIONE: 2000 pz. IN SCATOLA  
PACKAGING: 2000 pcs IN CARTON BOX

SPQ: 2000 pz. Descr. Std: HSG FOR FORK TERMINAL 6 CKT

EC NO: Z2006-0051 DRWN: FGOTTARD2005/10/12 CHKD: RSANDAN2005/10/12 APPR: GZUIN 2005/10/14	QUALITY SYMBOLS	GENERAL TOLERANCES (UNLESS SPECIFIED)	SCALE 2:1	DESIGN UNITS METRIC	FIRST ANGLE PROJECTION	REVISE ON CAD ONLY
	▽ -0	4 PLACES ± --- ± ---	mm INCH	DIMENSION STYLE MM ONLY	TITLE 6 CKT HOUSING FOR STRAIGHT FORK TERMINAL	
	▽ -0	3 PLACES ± --- ± ---		DRAWN BY DATE FGOTTARD 1995/10/25	MATERIAL NO. SEE TAB. DOCUMENT NO. SD-94529-008 SHEET NO. 1 OF 1	
		2 PLACES ± 0.1 ± ---		CHECKED BY DATE SSORATO 1995/10/25	APPROVED BY DATE RMARTUCC 1995/10/25	
	1 PLACE ± 0.2 ± ---	ANGULAR ± 2 °				
		DRAFT WHERE APPLICABLE MUST REMAIN WITHIN DIMENSIONS				
A4	REV					